

ASSEMBLY INSTRUCTIONS

Corner Cabinet

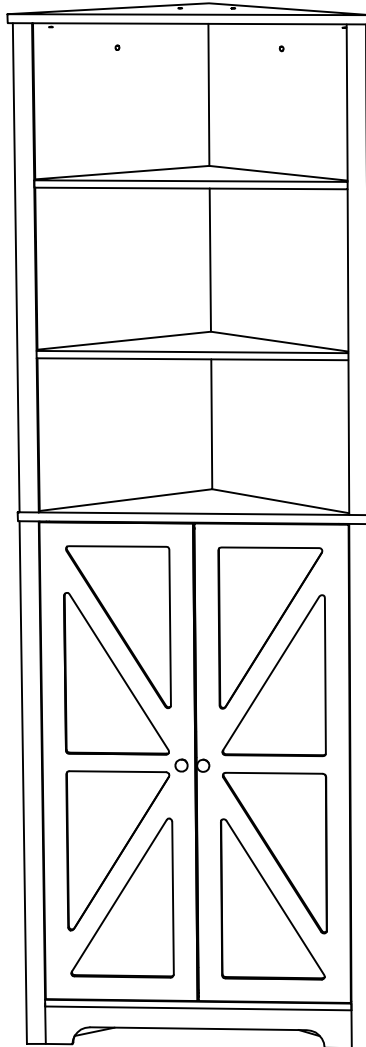

NOTE TO CUSTOMERS:

- For ease and speed of assemble we recommend that before you commence each step of the assembly that you identify all the parts required to complete that step.
- We recommend that where possible you allow sufficient space to assemble the item as close as possible to the place where it will be once assembled.
- For the protection of your furniture we recommend that the product is placed on protected surfaces during assembly to prevent any damage.
- During assembly do not over tighten, as this may damage the product.
- Please ensure you retain all the product packaging until the item completely assembled.
- Please periodically check all fittings and re-tighten as necessary.
- Please never allow any liquids to remain on your furniture as absorption can cause the wood to warp or the finish to de-laminate.
- It is recommended that this item should be assembled by two adults.

To use a cam lock: (Please read below instructions before assembling)







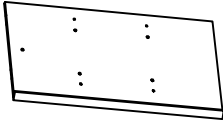

	<p>Diagram A</p>	<p>1. Insert cam screw into hole as shown in diagram A .</p>
	<p>Diagram B</p>	<p>Make sure not to insert the cam screw: Too deep as shown in figure B as this will cause the cam screw to be misaligned and unable to interlock properly.</p>
	<p>Diagram C</p>	<p>Also avoid inserting the cam screw too close to the surface of the hole as shown in figure C, as this will cause the cam lock to be too loose, and not interlock properly.</p>

	<p>2. Connect the panels together.</p>
	<p>3. When inserting the cam lock make sure the arrow of the cam lock faces the cam screw.</p>
	<p>4. To tighten the cam lock turn the cam lock clockwise 90-180 degree or until the arrow is facing opposite the place cam lock was inserted.</p> <p>NOTE: DO NOT USE AN AUTOMATIC SCREWDRIVER TO TIGHTEN CAM LOCKS.</p>

Note:

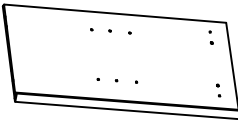
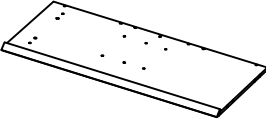
- Read these instructions carefully before assembling.
- Tools required : Phillips screwdriver, flat screwdriver.
- Find a clean, smooth area on which to work , such as a carpet, in order to avoid scratching the wood surfaces.
- Wait to dispose of the packing material until assembly is complete and all parts and hardware are accounted for.
- Two or more people might be required for assembly.



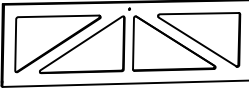

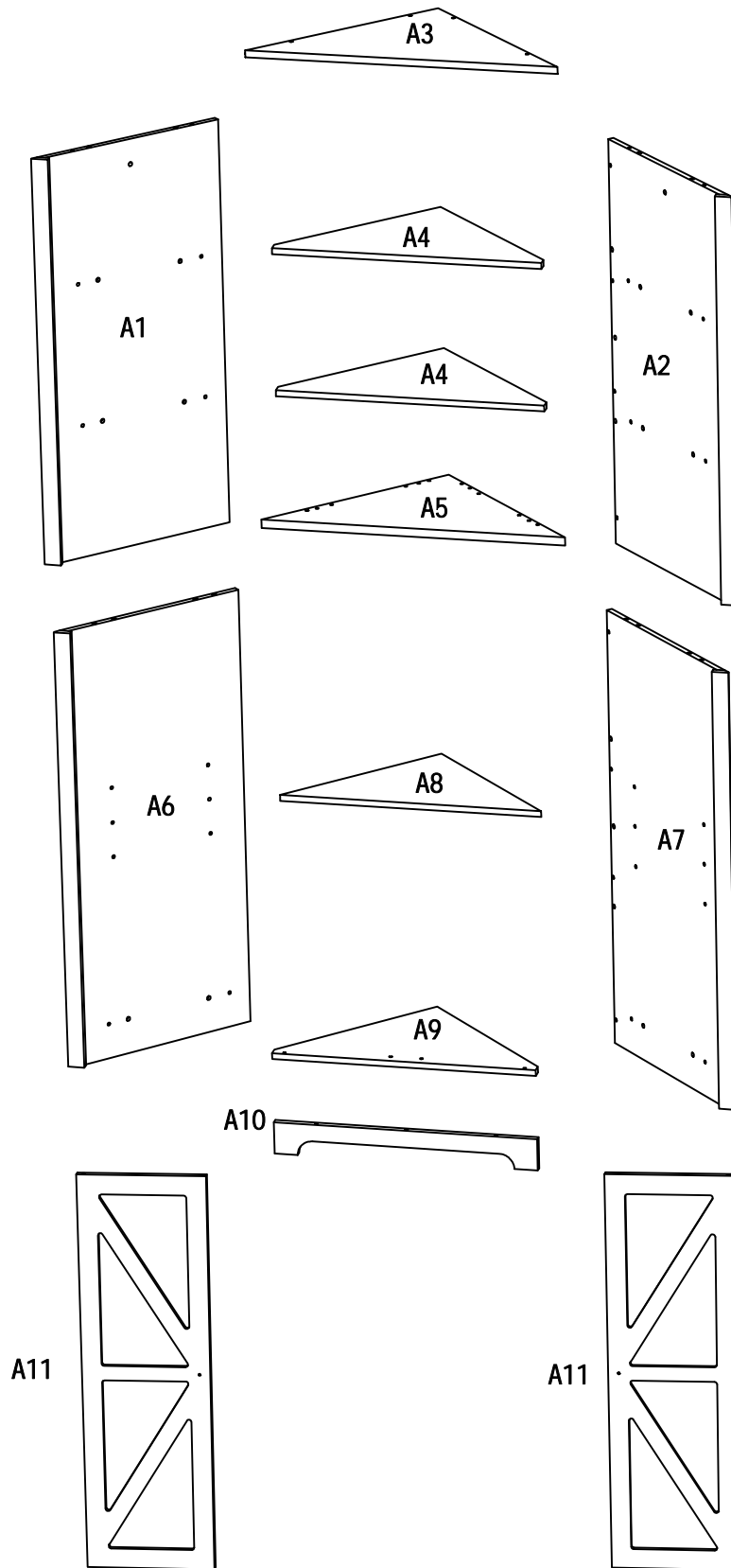

Part List

<p>A1. Qty: 1</p>  <p>Upper Left Side Panel</p>	<p>A2. Qty: 1</p>  <p>Upper Right Side Panel</p>	<p>A3. Qty: 1</p>  <p>Top Panel</p>	<p>A4. Qty: 2</p>  <p>Fixed Shelf</p>
<p>A5. Qty: 1</p>  <p>Divider</p>	<p>A6. Qty: 1</p>  <p>Lower Left Side Panel</p>	<p>A7. Qty: 1</p>  <p>Lower Right Side Panel</p>	<p>A8. Qty: 1</p>  <p>Shelf</p>
<p>A9. Qty: 1</p>  <p>Bottom Panel</p>	<p>A10. Qty: 1</p>  <p>Apron</p>	<p>A11. Qty: 2</p>  <p>Left Door & Right Door</p>	

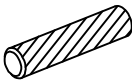
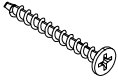
Part List

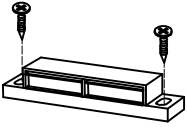

Hardware List

<p>B1. Qty:32</p>  <p>Wood Dowel</p>	<p>B2. Qty:31</p>  <p>Screw</p>	<p>B3. Qty:4</p>  <p>Cam- Lock</p>	<p>B4. Qty:2</p>  <p>Knob with bolt</p>
<p>B5. Qty:4</p>  <p>Door Pin</p>	<p>B6. Qty:2</p>  <p>Magnet with screw</p>	<p>B7. Qty:2</p>  <p>Anchor with screw</p>	<p>B8. Qty:4</p>  <p>Shelf Support</p>

APPENDIX: Dimension of Hardware in this AI.

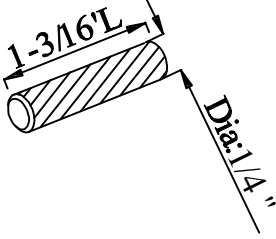
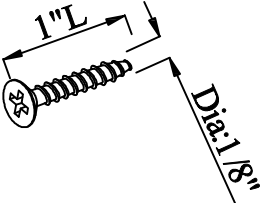
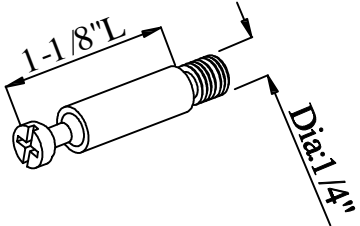
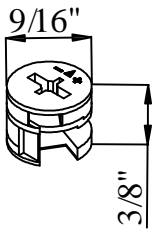
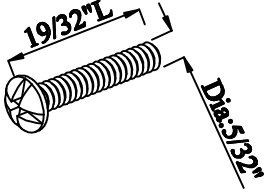
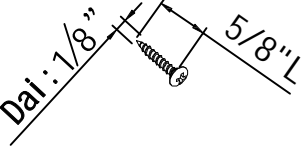
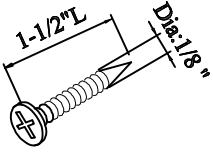
<p>B1.</p>  <p>Wood Dowel</p>	<p>B2.</p>  <p>Screw</p>	<p>B3.</p>  <p>Cam-bolt</p>
<p>B3.</p>  <p>Cam-nut</p>	<p>B4.</p>  <p>bolt</p>	<p>B6.</p>  <p>screw</p>
<p>B7.</p>  <p>screw</p>		

Assembly instruction

Step 1:

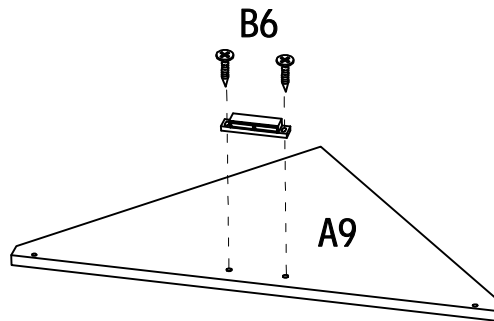
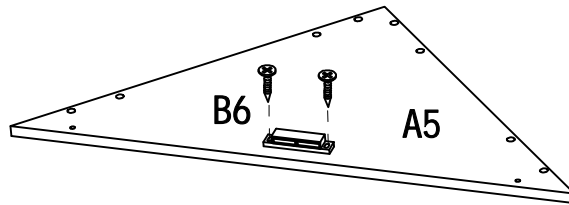
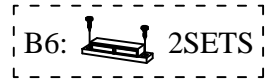

Assemble Magnet B6 with screws to Divider A5 & Bottom Panel A9 as shown above.

Step 2:

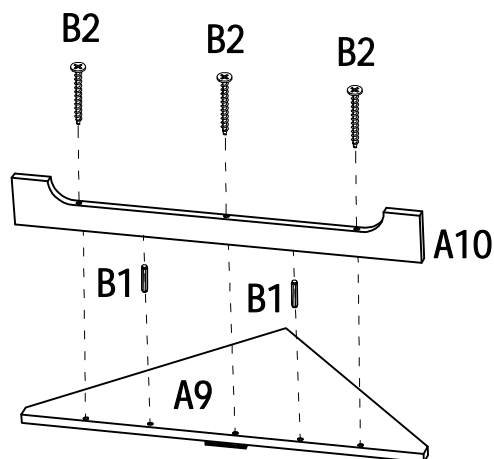
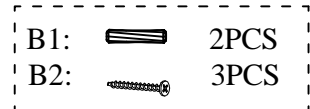

Assemble Apron A10 to Bottom Panel A9 using Screws B2 & Wooden Dowels B1 as shown above.

Step 3:

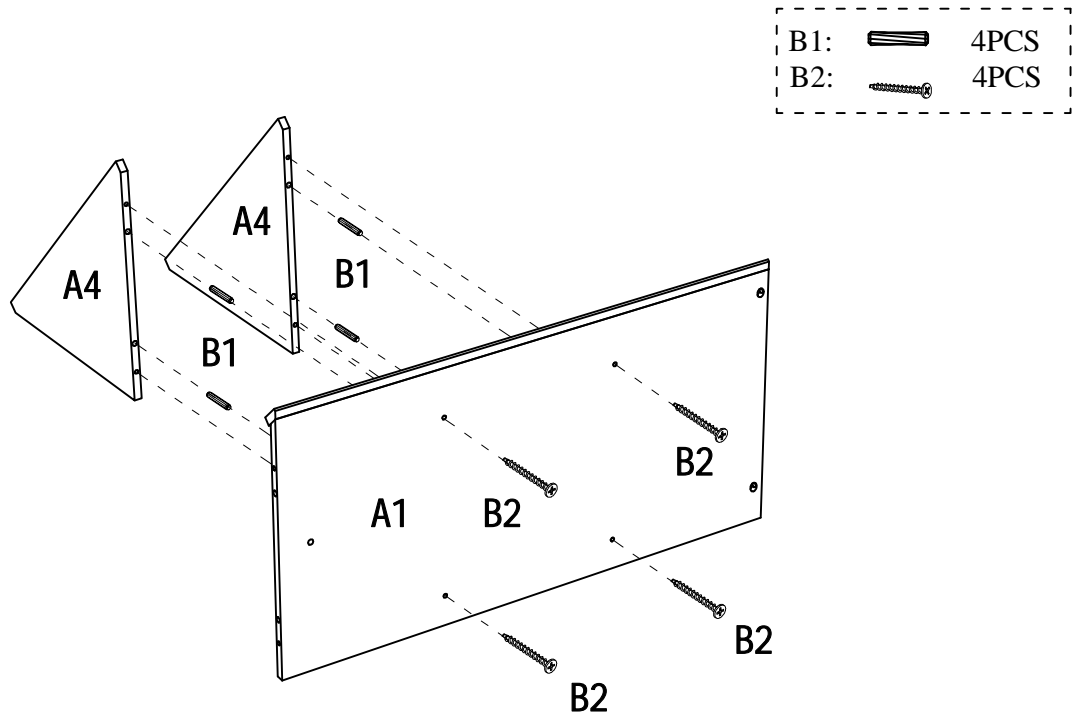

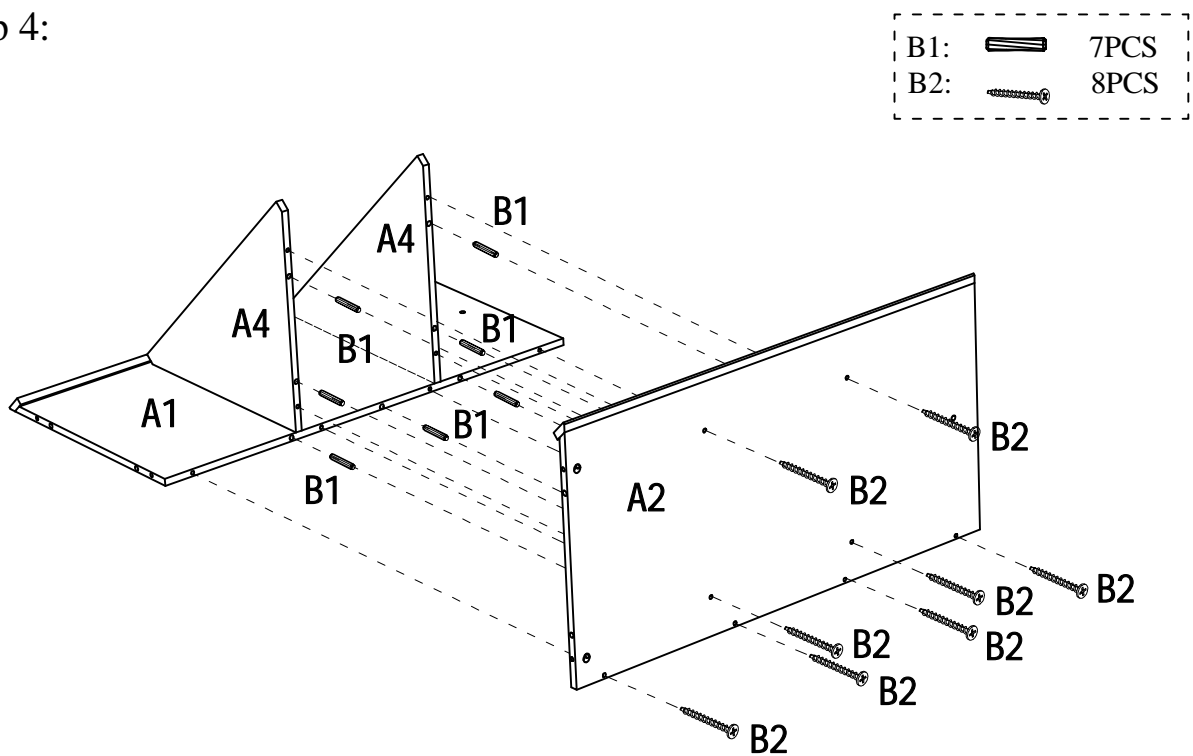

Assemble Fixed Shelves A4 to Upper Left Side Panel A1 using Wooden Dowels B1 & Screws B2 as shown above.

Step 4:



Assemble Fixed Shelves A4 and Upper Left Side Panel A1 to Upper Right Side Panel A2 using Screws B2 & Wooden Dowels B1 as shown above.

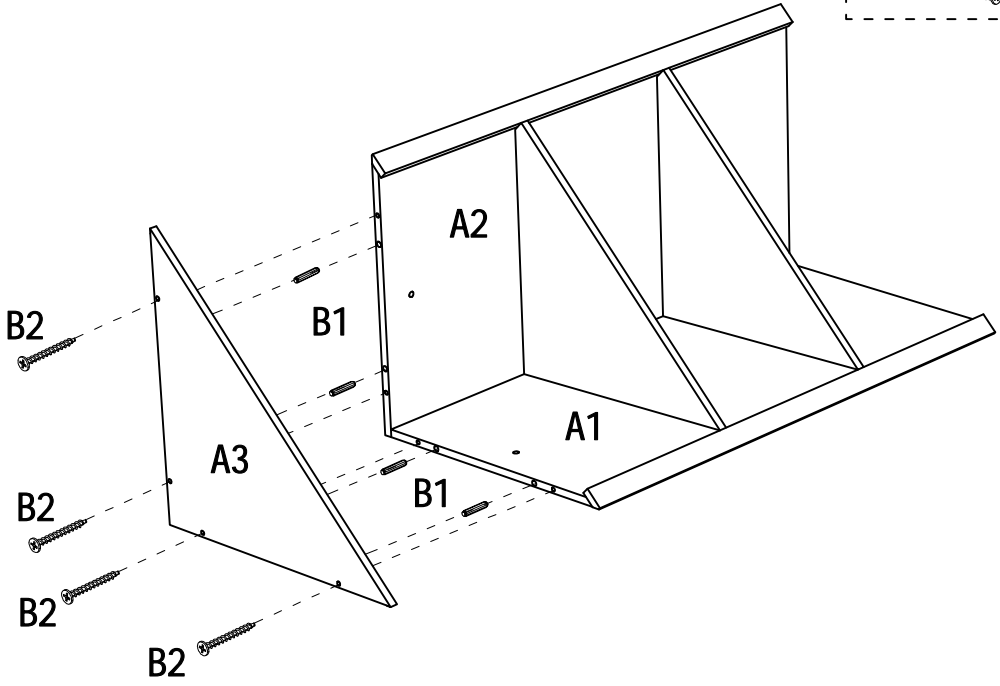

Step 5:

- B1:  4PCS
- B2:  4PCS



Assemble Top Panel A3 to Upper Left Side Panel A1 & Upper Right Side Panel A2 using Wooden Dowels B1 & Screws B2 as shown above.

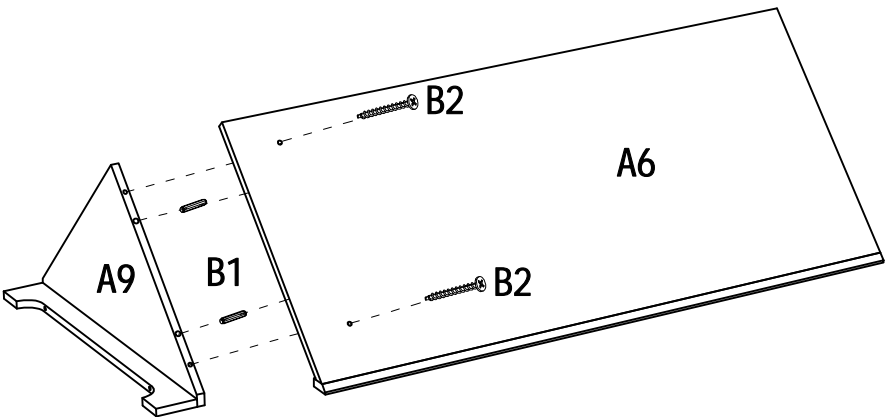

Step 6:

- B1:  2PCS
- B2:  2PCS



Assemble Bottom Panel A9 to Lower Left Side Panel A6 using Wooden Dowels B1 & Screws B2 as shown above.

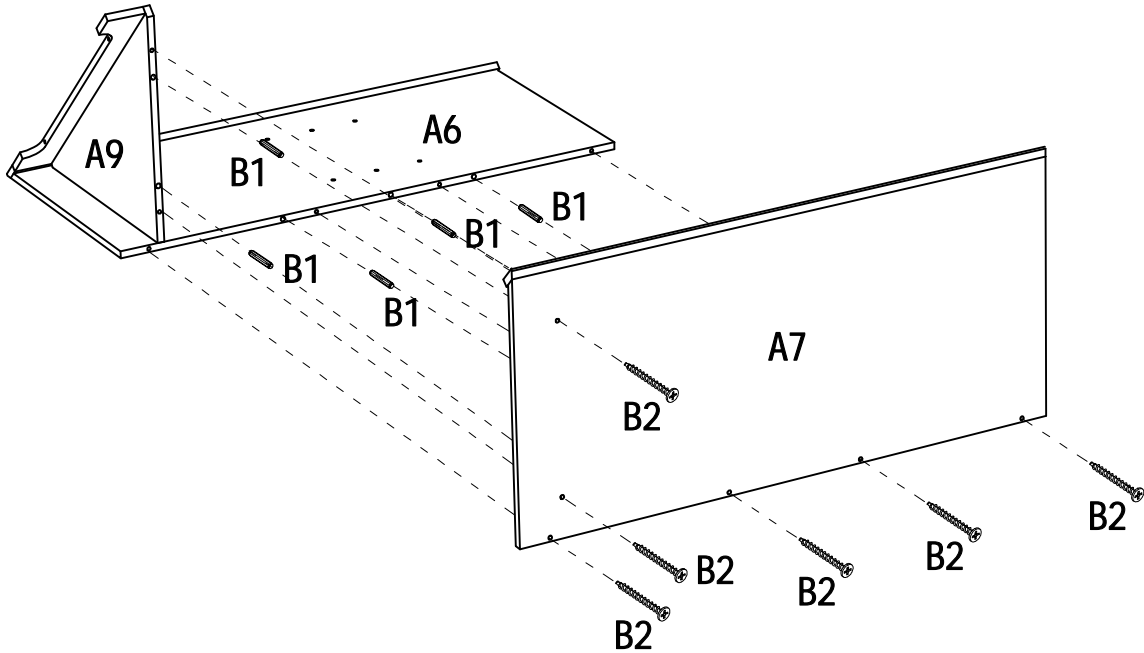

Step 7:

- B1:  5PCS
- B2:  6PCS



Assemble Bottom Panel A9 and Lower Left Side Panel A6 to Lower Right Side Panel A7 using Wooden Dowels B1 & Screws B2 as shown above.

Step 8:

- B1:  4PCS
- B2:  4PCS

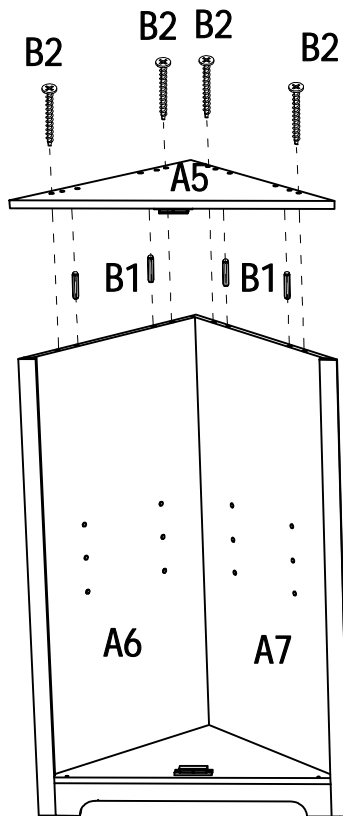

Assemble Divider A5 to Lower Left Side Panel A6 and Lower Right Side Panel A7 using Wooden Dowels B1 & Screws B2 as shown above.

Step 9:

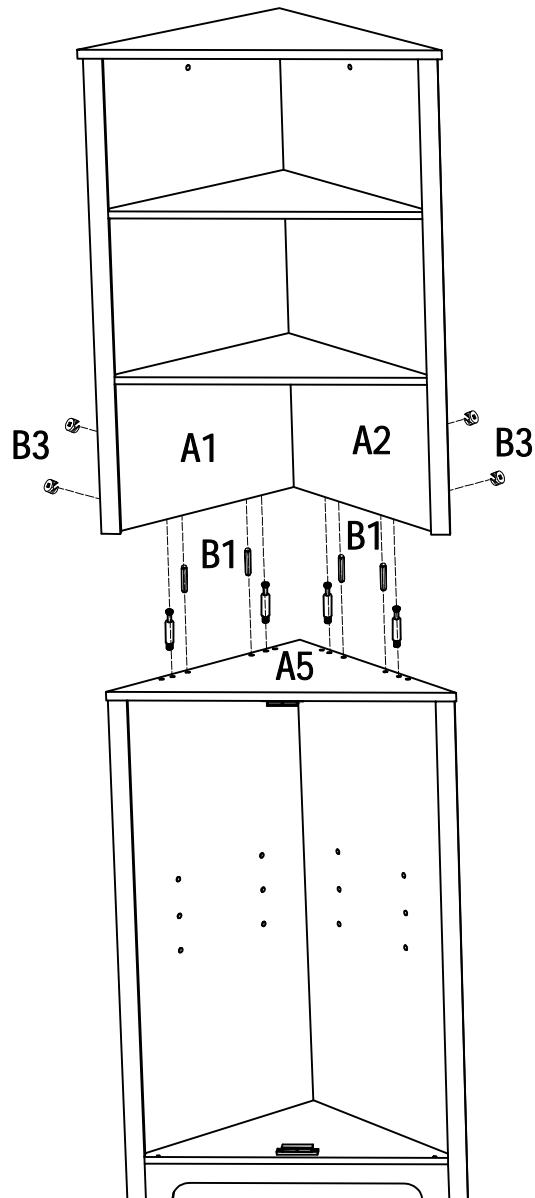

Assemble Upper Side Panels A1 & A2 to Divider A5 using Wooden Dowels B1 & Cam-locks B3 as shown above.

Step 10:

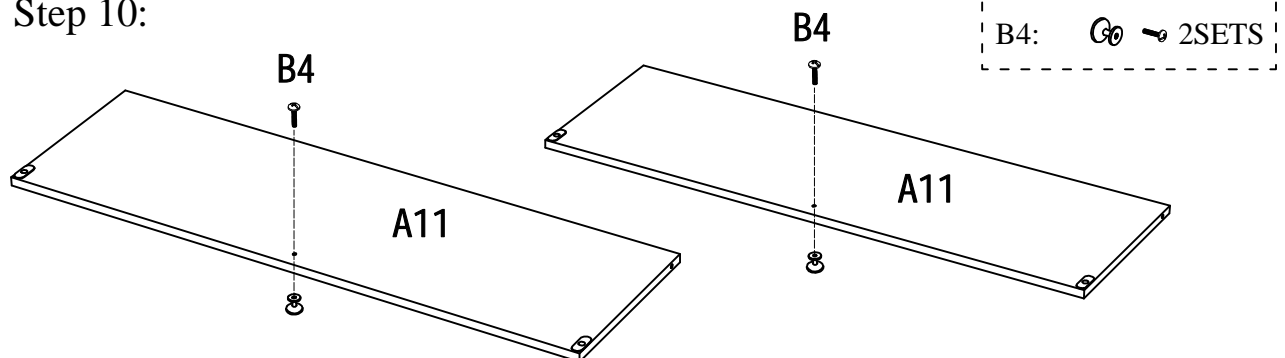

Assemble Knobs B4 to the door using included bolts as shown above.

Step 11:

B5:  4PCS

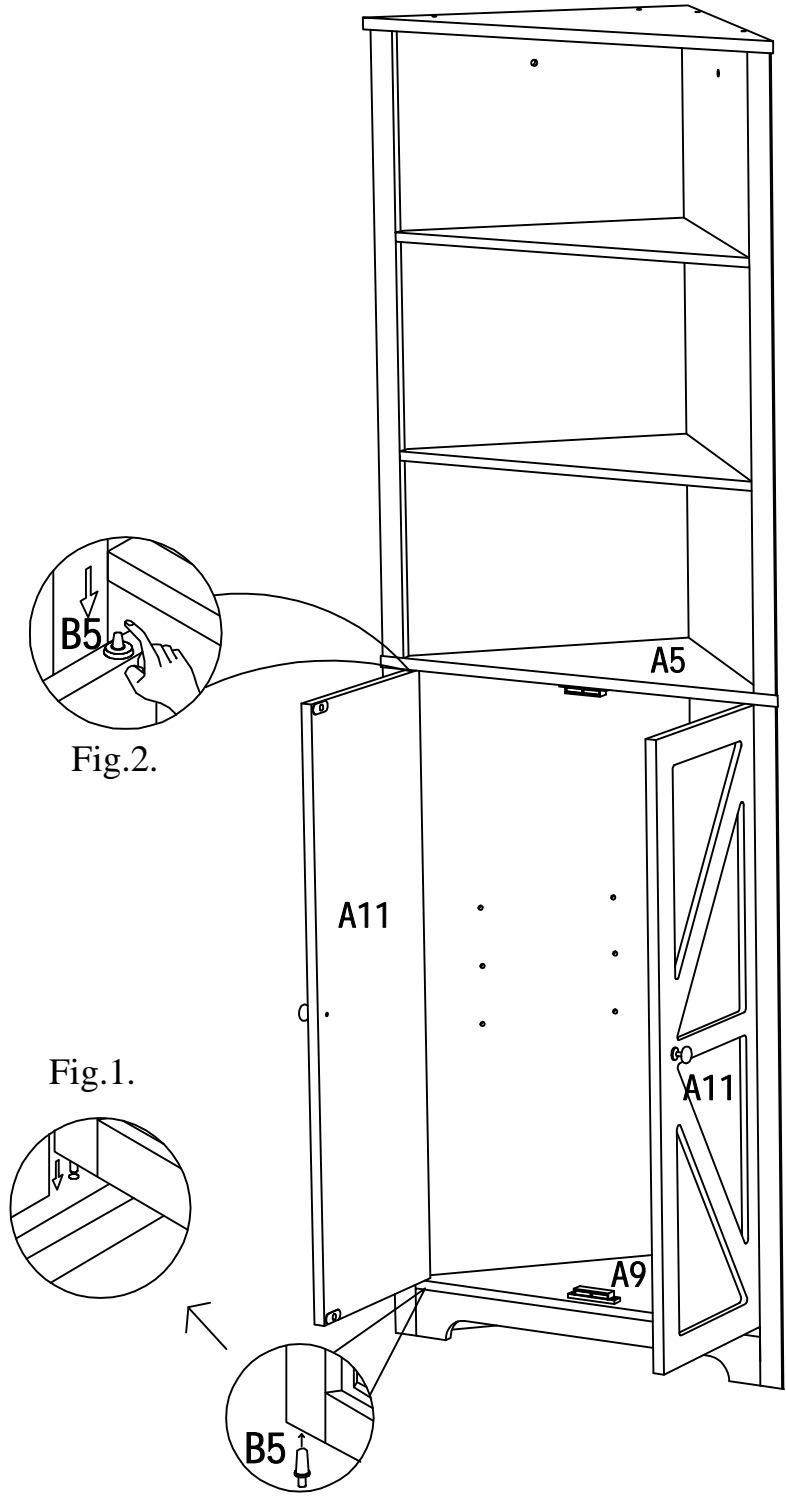

- 1): Connect Door A11 to the Divider A5 ,refer to Fig.1. Press the Upper Pin B5 on Door A11 see Fig.2. and insert Door A11 carefully into the cabinet with the upper pin popping up into the hole of Divider A5.
- 2): Repeat above step to assemble the other door .

Step 12:

B8:  4PCS

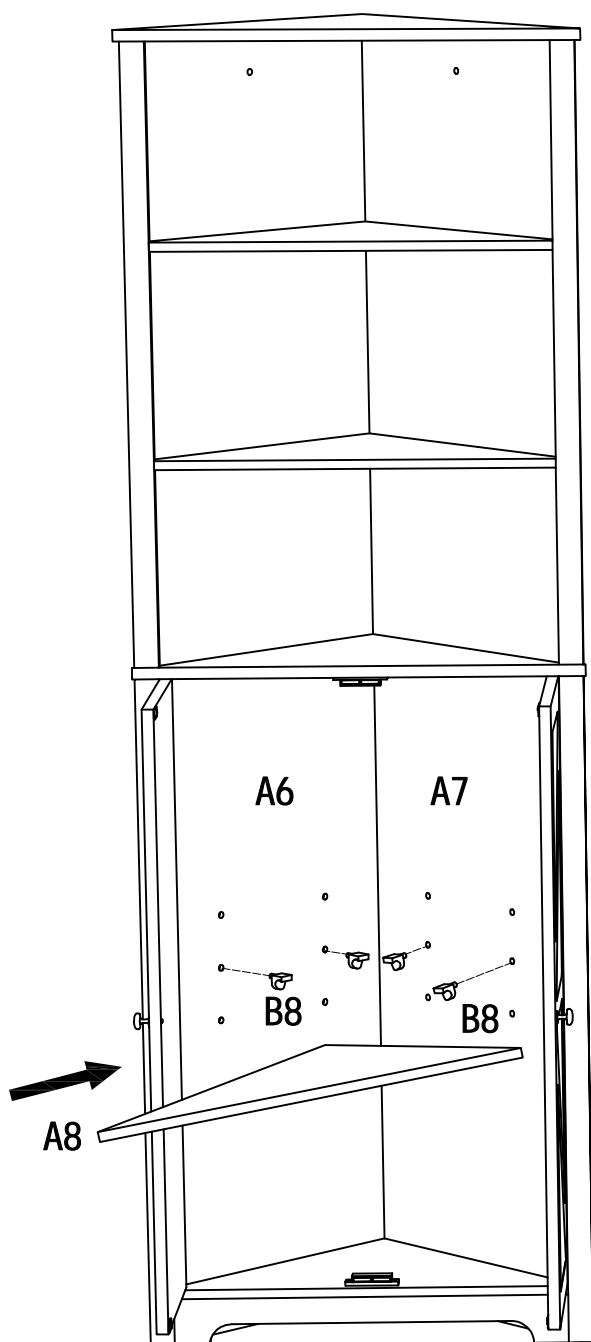

Insert Shelf Supports B8 into holes on Lower Side Panels A6 & A7, then place Shelf A8 onto shelf supports as shown above.

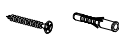
B7:  2SETS

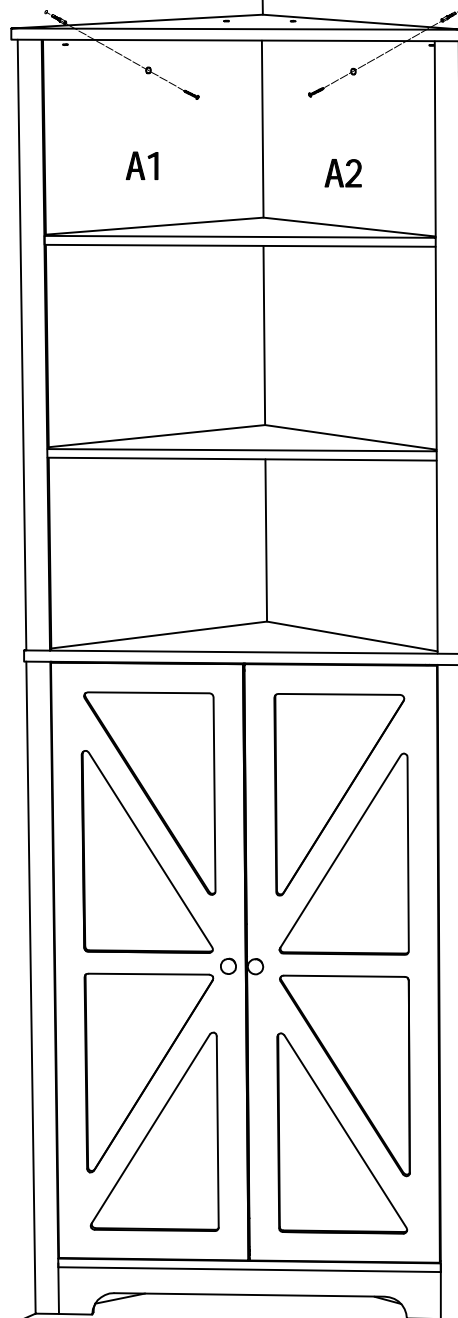
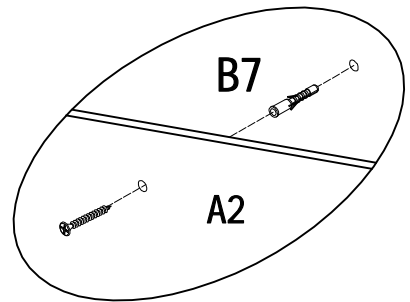

For your safety, please attached unit to the wall with Anchor B7 as shown above.