



# ASSEMBLY INSTRUCTIONS

## BAR CABINET

ASSEMBLY REQUIREMENTS	1.5 Hours Assembly Time (Approximate)	2 -Person Assembly 	Tools Required (Not Provided): Phillips Screwdriver  Flat Head Screwdriver 
-----------------------	---	---	---

### Thank you for purchasing our product!

Please refer and use this assembly instruction to assemble the product.  
Contact our customer service department in case there are any missing or damage parts or hardware.  
Replacement parts are normally shipped within 2 or 3 days.

**We appreciate your business!**

**PRODUCTS PURCHASED THROUGH OUR AUTHORIZED VENDORS ONLY ARE ELIGIBLE FOR REPLACEMENT PARTS.**

**THIS PRODUCT IS FOR INDOOR AND HOUSEHOLD USE ONLY - NOT FOR COMMERCIAL USE.**

### ASSEMBLY PREPARATION

1. Remove all packaging materials, staples and packing straps from the carton.
2. Refer to Parts List and Hardware List and ensure they are correct before assembly.  
Contact customer service for missing parts.
3. Place all wooden parts on a clean, flat and soft surface (e.g. carpet or rug) to prevent parts from getting scratched.

### SAFETY PRECAUTION

1. KEEP ALL HARDWARE PARTS OUT OF REACH OF CHILDREN.
2. DISPOSE PLASTIC PACKAGING MATERIAL IMMEDIATELY TO AVOID ANY RISK OF SUFFOCATION TO CHILDREN AND ANIMALS.

### TIPS FOR ASSEMBLY

1. Allow ample room for assembly and in close proximity to where product will be placed.
2. Assemble the product on a surface that does not scratch or damage the exterior gloss and finish of the furniture.
3. Identify all of the parts, hardware and quantities required for each step.
4. During assembly, do not over-tighten any fittings as this may cause damage.
5. DO NOT USE POWER TOOLS TO ASSEMBLE THIS PRODUCT.
6. Always place the product on a flat, level surface.
7. Do not sit or stand on the partially assembled product; only use the product for which it is intended.

### CARE AND MAINTENANCE







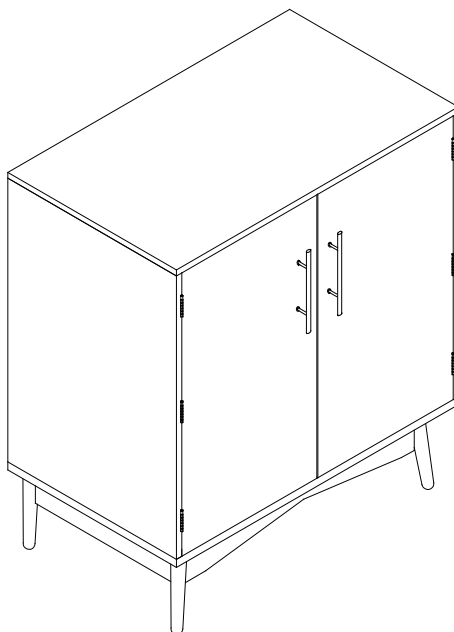









1. Wipe clean with a soft, dry cloth; avoid the use of harsh chemicals or household cleaners as they may damage the exterior finish of the furniture.
2. Hardware may loosen over time. Periodically, check that all connections are tight; re-tighten as necessary.
3. Solid wood is impacted by heat and humidity fluctuations which may cause small joint separations or hairline cracks; place the furniture away from direct sunlight and air conditioning vents, heating vents or units to protect the furniture.

# ASSEMBLY INSTRUCTIONS

## BAR CABINET









### Hardware List

ITEM	DESCRIPTION	PART	QTY	ITEM	DESCRIPTION	PART	QTY
A	Cam-bolt	 6*35mm	42 pcs	K	Screw	 4*25mm	3 pcs
B	Cam-lock	 15*10mm	42 pcs	L	Hinge		6 pcs
C	Wood Dowel	 8*30mm	50 pcs	M	Screw	 2.5*10mm	22 pcs
D	Handle Bolt	 4*16mm	4 pcs	N	Bolt	 6*50mm	4 pcs
E	Handle		2 pcs	O	Spring Washer		4 pcs
F	Magnetic Catch		1 pc	P	Flat Washer		4 pcs
G	Door Plate		2 pcs	Q	Allen Wrench		1 pc
H	Screw	 3*14mm	2 pcs	R	Plastic Anchor		2 pcs
I	Screw	 3*12mm	44 pcs	S	Bracket		2 pcs
J	Screw	 4*40mm	10 pcs	T	Screw	 3.5*12mm	2 pcs

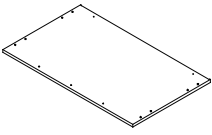
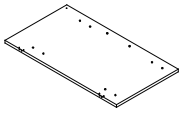
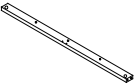
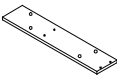
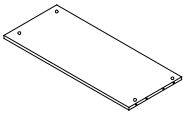
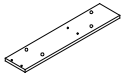
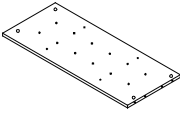
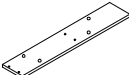
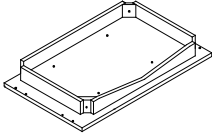
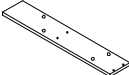
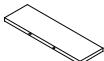
# ASSEMBLY INSTRUCTIONS

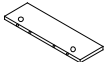
## BAR CABINET

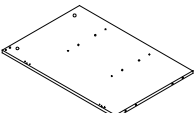
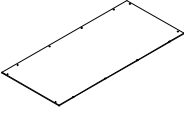
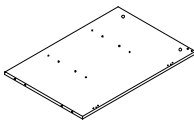
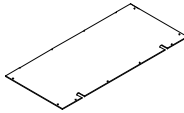
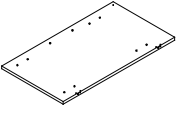
### Parts List

ITEM	DESCRIPTION	PART	QTY	ITEM	DESCRIPTION	PART	QTY
1	Top Panel		1 pc	11	Right Door		1 pc
2	Connect Bar		1 pc	12	Short Left Panel		1 pc
3	Upper Shelf		1 pc	13	Short Right Panel		1 pc
4	Lower Shelf		1 pc	14	Long Left Panel		1 pc
5	Cabinet Base		1 pc	15	Long Right Panel		1 pc
6	Divide Panel		4 pcs	16	Shelf		4 pcs
7	Divide Panel		2 pcs	17	Metal Rod		4 pcs
8	Left Panel		1 pc	18	Lower Back Panel		1 pc
9	Right Panel		1 pc	19	Upper Back Panel		1 pc
10	Left Door		1 pc	20	Leg		4 pcs

# ASSEMBLY INSTRUCTIONS

## BAR CABINET

### Parts List Assembly Overview

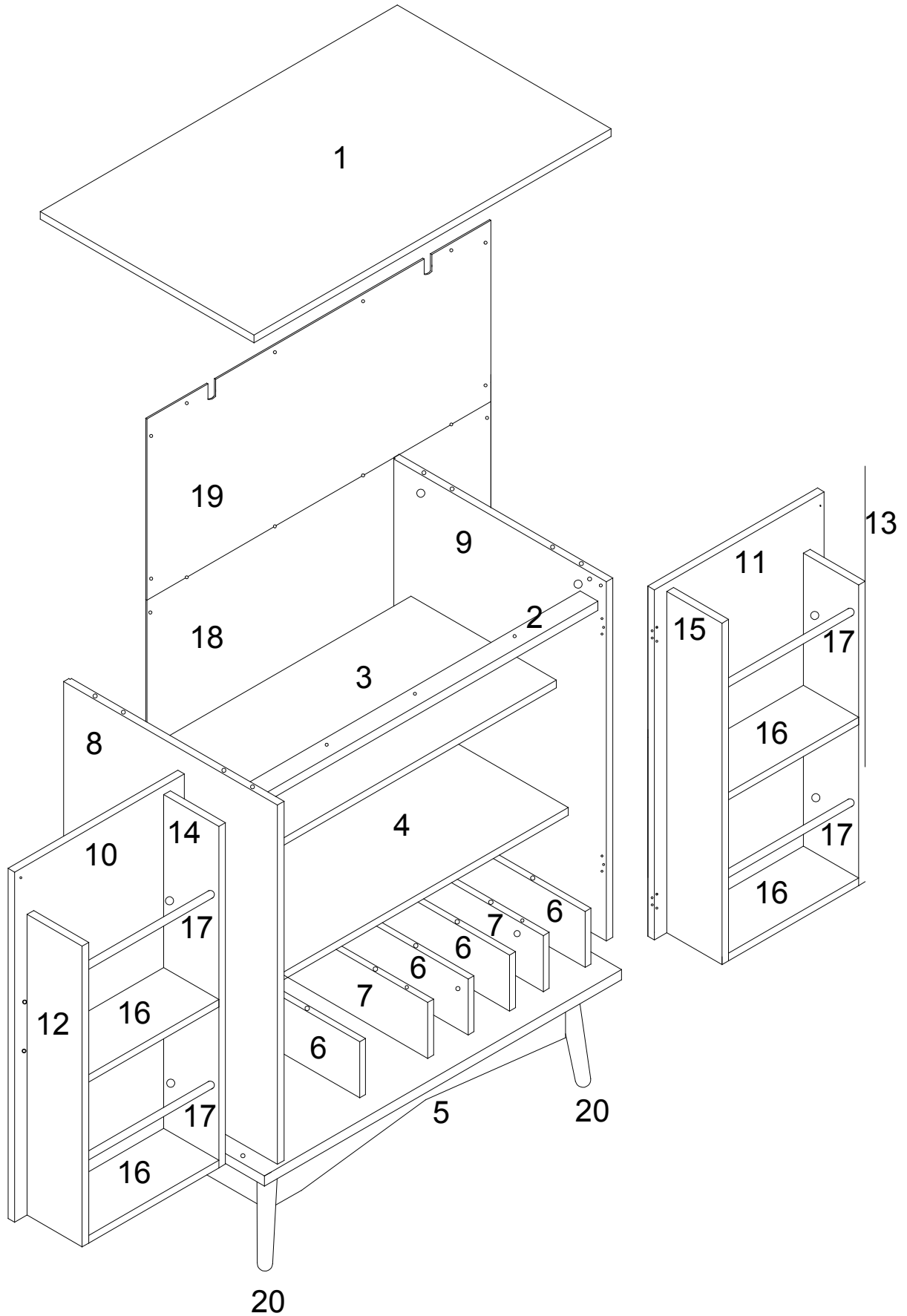

# Instructions For Fastening CAM-BOLT AND CAM-LOCK



CAM-BOLT



CAM-LOCK

## Tools Required

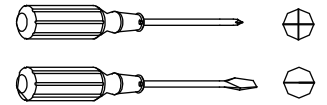

### INSERTING AND TIGHTENING CAM-BOLT

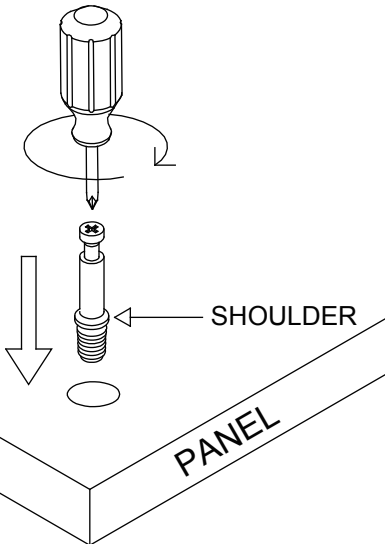

Place Cam-bolt on pre-drilled hole and screw in vertically.

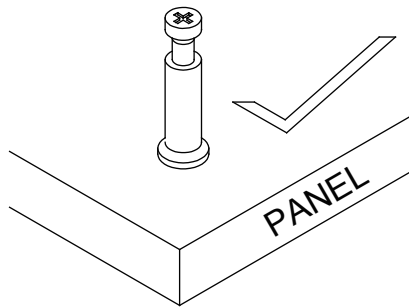

Shoulder is flushed (on the same level) with the panel.

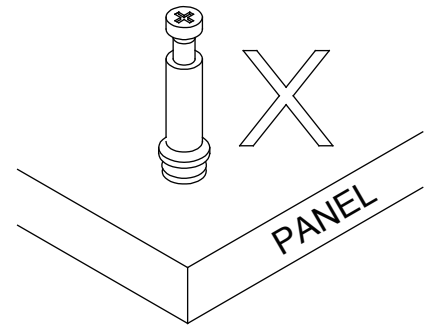

Shoulder is above the panel.

Place Cam-bolt to the designated pre-drilled holes on the panel. Use a Phillips Screwdriver to tighten Cam-bolt vertically until shoulder is flushed (on the same level) with panel. Do not over-tighten or under-tighten.

### INSERTING CAM-LOCK

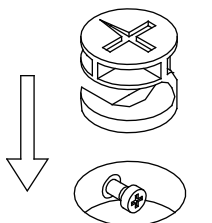

Insert Cam-lock with arrow align to Cam-bolt head.

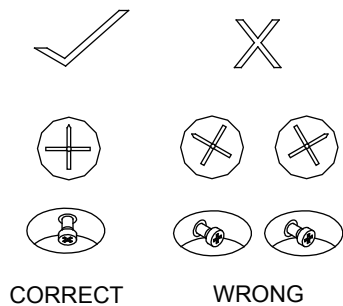

CORRECT

WRONG

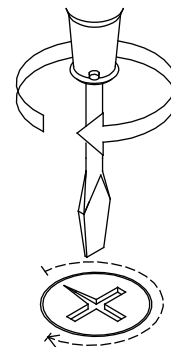

Align the arrow on the Cam-lock to the Cam-bolt head and insert the Cam-lock. Ensure Cam-lock is fully inserted.

### TIGHTENING CAM-LOCK



Use a Flat-head Screwdriver to turn Cam-lock clockwise so it locks onto the head of the Cam-bolt. Turn until it is snug (about 3/4ths of a turn) -- over-tightening could damage Cam-lock or/and Cam-bolt.

# STEP 1

A		42 pcs
S		2 pcs
T	 3.5*12mm	2 pcs

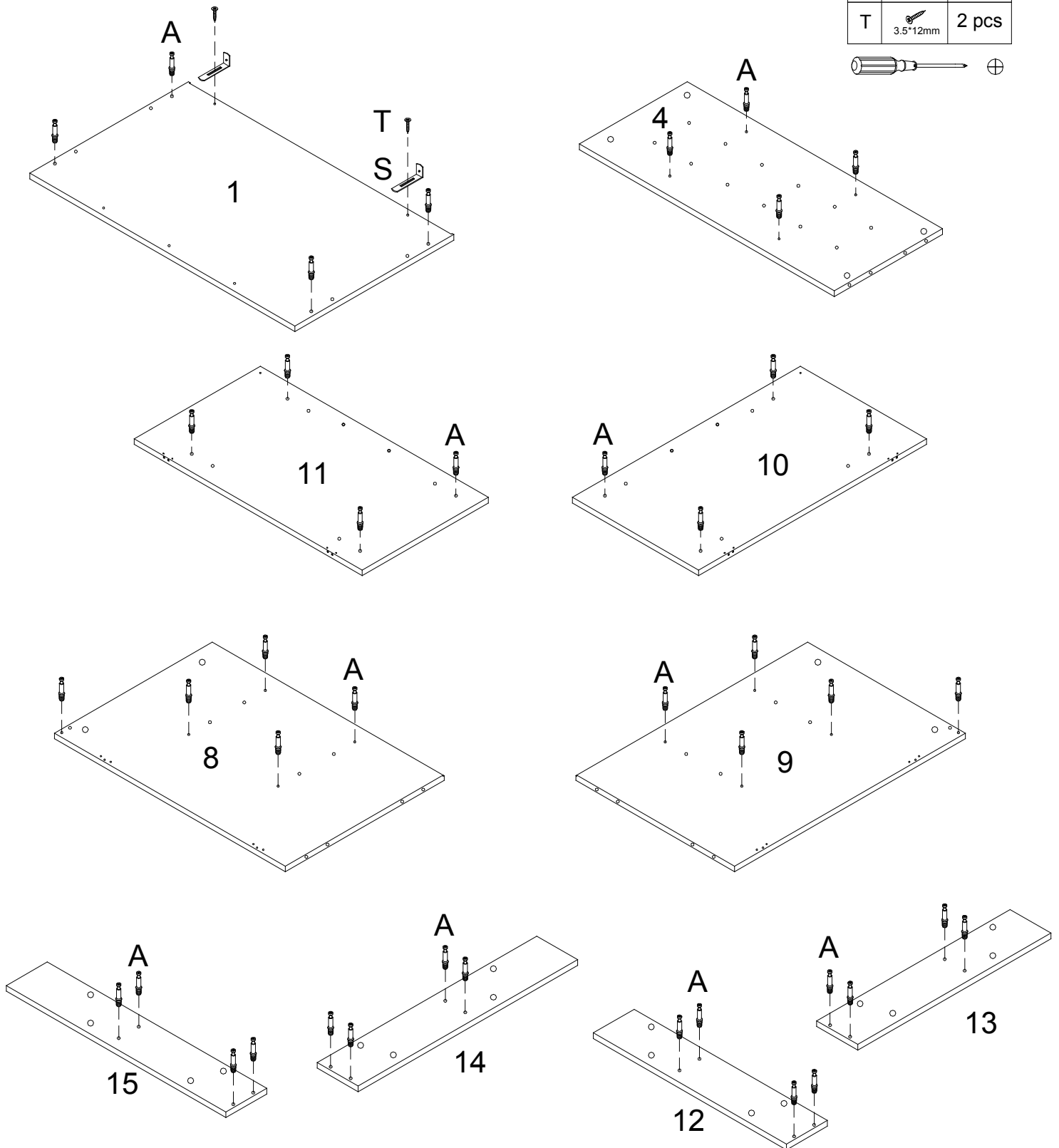

- Lay Top Panel (1), Lower Shelf (4), Left Panel (8), Right Panel (9), Left and Right Door (10 & 11), Short Left and Right Panel (12 & 13) and Long Left and Right Panel (14 & 15) as shown on a material that does not scratch the surface of each part.
- Screw in Cam-bolt (A) into the designated holes on each. Refer to Page 5 for instructions on inserting and tightening Cam-bolt.
- Attach Bracket (S) to (1) by using Screw (T) as shown.

## STEP 2

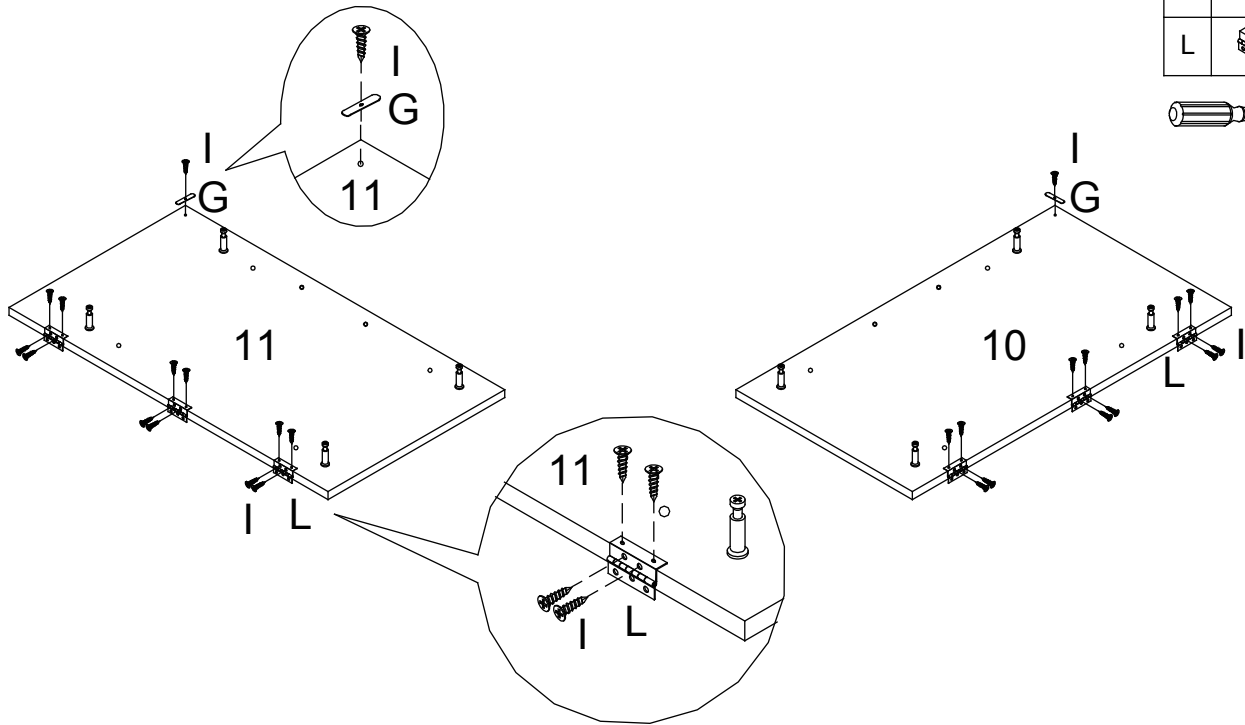

- Attach Door Plate (G) to Left and Right Door (10 & 11) using Screw (I).
- Attach door wing of Hinge (L) to (10 & 11) using Screw (I) as shown.

## STEP 3

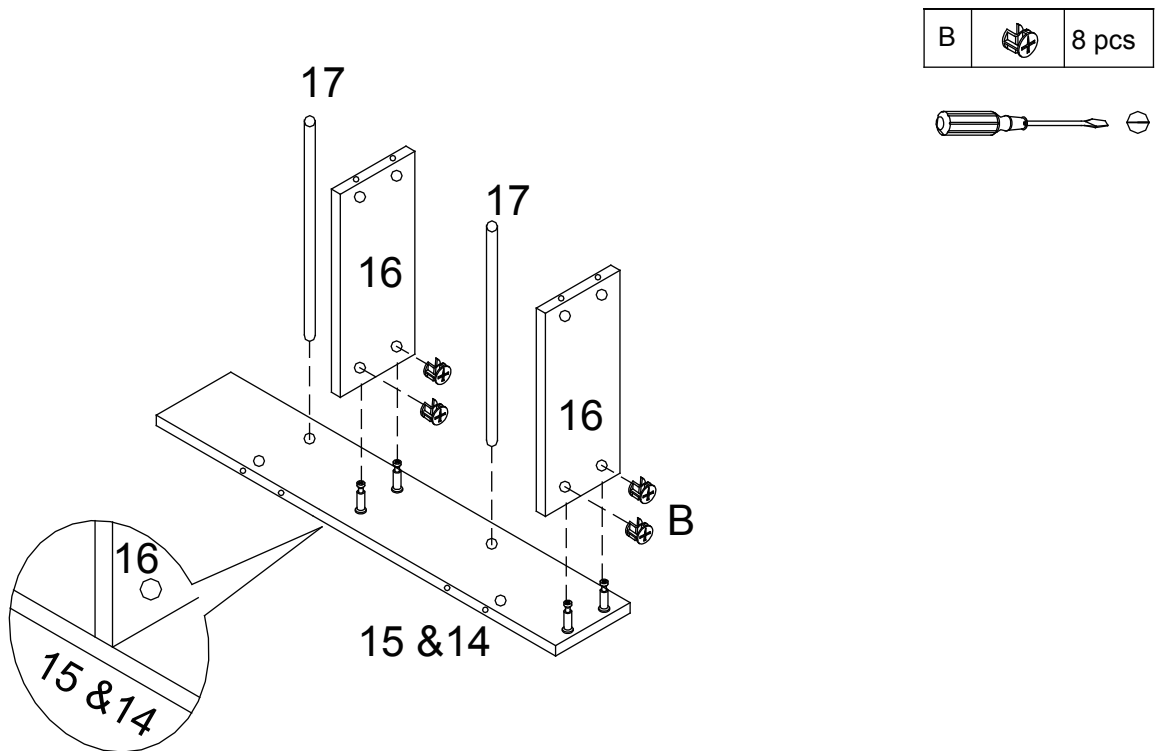

- Attach Shelf (16) to Long Right and Left Panel (15 & 14) via Cam-bolts on (15 & 14).
- Insert Cam-lock (B) into the holes on (16) then turn clockwise to lock onto Cam-bolt.
- Insert Metal Rod (17) into the designated hole on (15 & 14). Refer to Page 5 for instructions on inserting and tightening Cam-bolt.

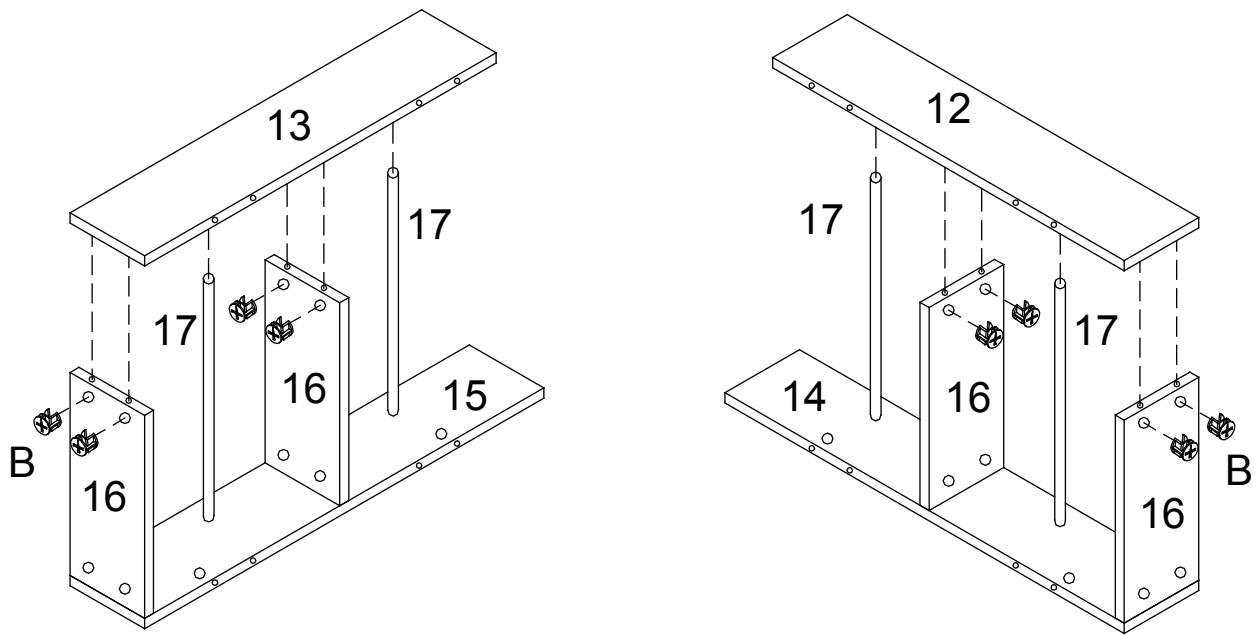
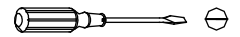

## STEP 4

B		8 pcs
---	--	-------



- a) Attach Short Right and Left Panel (13 & 12) to Shelf (6) via Cam-bolts on (13 & 12) and Metal Rod (17).  
b) Insert Cam-lock (B) into the holes on (16) then turn clockwise to lock onto Cam-bolt.

## STEP 5

B		8 pcs
C		8 pcs

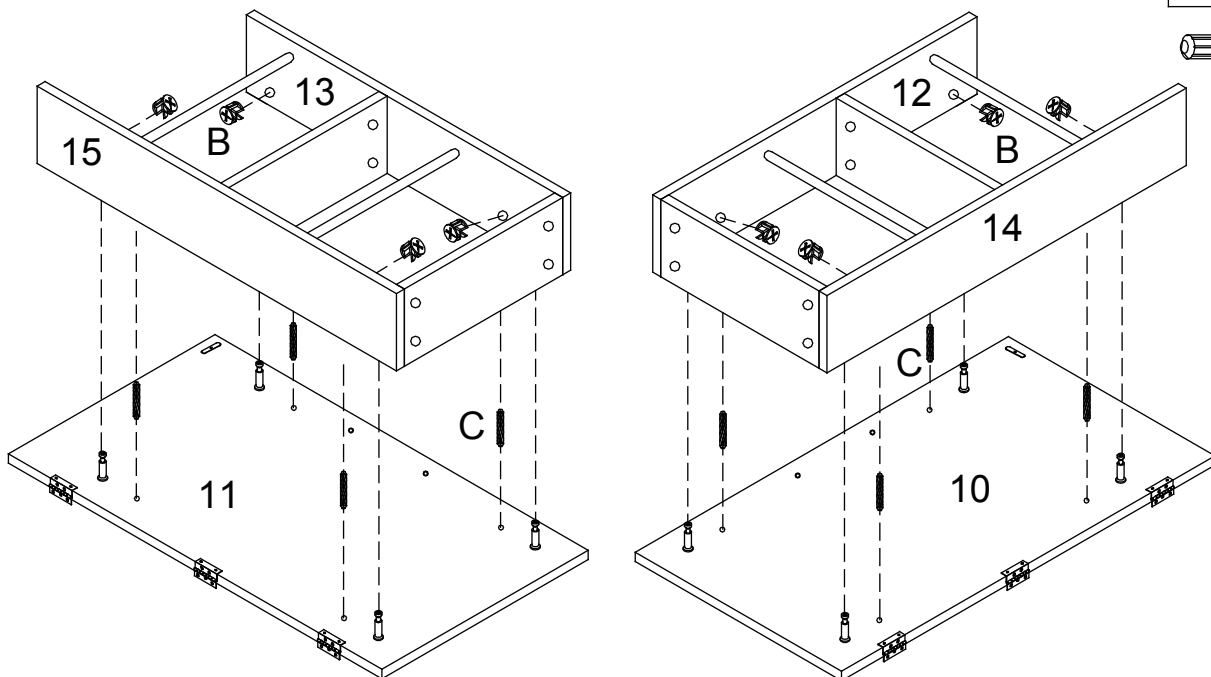
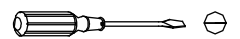



- a) Insert Wood Dowel (C) to designated hole on Right and Left Door (11 & 10).  
b) Attach the assembly unit from Step 4 to (11 & 10) via Cam-bolts and Wood dowels.  
c) Insert Cam-lock (B) into the holes on (12 & 13 and 14 & 15) then turn clockwise to lock onto Cam-bolt.

## STEP 6

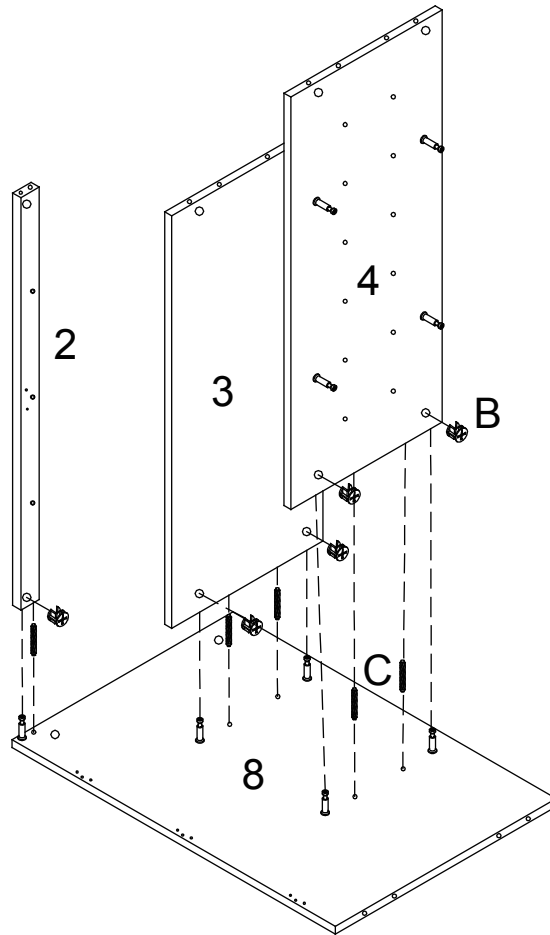
- a) Insert Wood Dowel (C) into designated hole on Connect Bar (2), Upper Shelf (3) and Lower Shelf (4).
- b) Attach (2, 3 & 4) to Left Panel (8) via Cam-bolts on (8) and Wood dowels.
- b) Insert Cam-lock (B) into the holes on (2, 3 & 4) then turn clockwise to lock onto Cam-bolt.



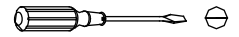

B		5 pcs
C		5 pcs

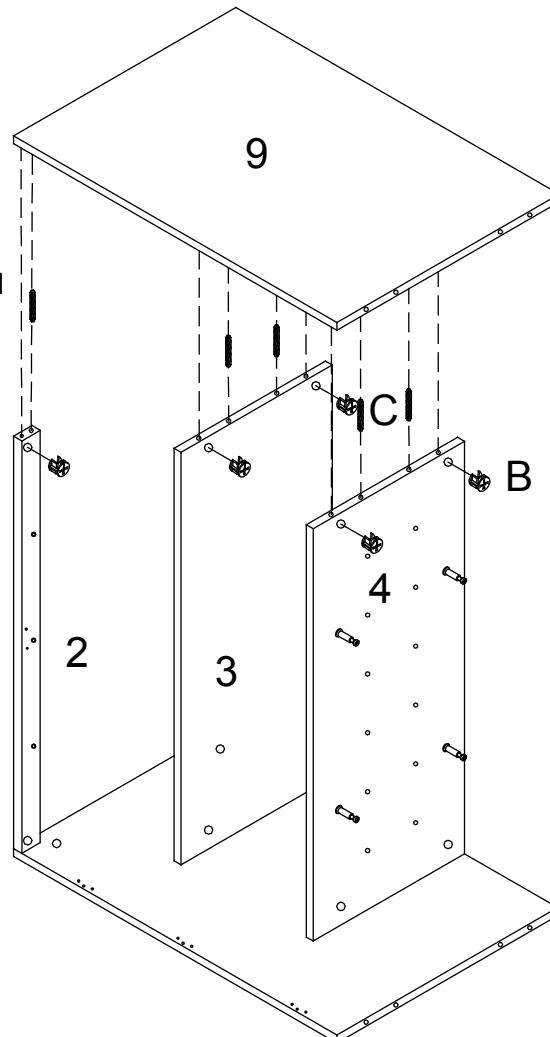

## STEP 7

- a) Insert Wood Dowel (C) into designated hole on Connect Bar (2), Upper Shelf (3) and Lower Shelf (4).
- b) Attach Right Panel (9) to (2, 3 & 4) via Cam-bolts on (9) and Wood dowels.
- b) Insert Cam-lock (B) into the holes on (2, 3 & 4) then turn clockwise to lock onto Cam-bolt.



B		5 pcs
C		5 pcs

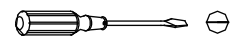

## STEP 8

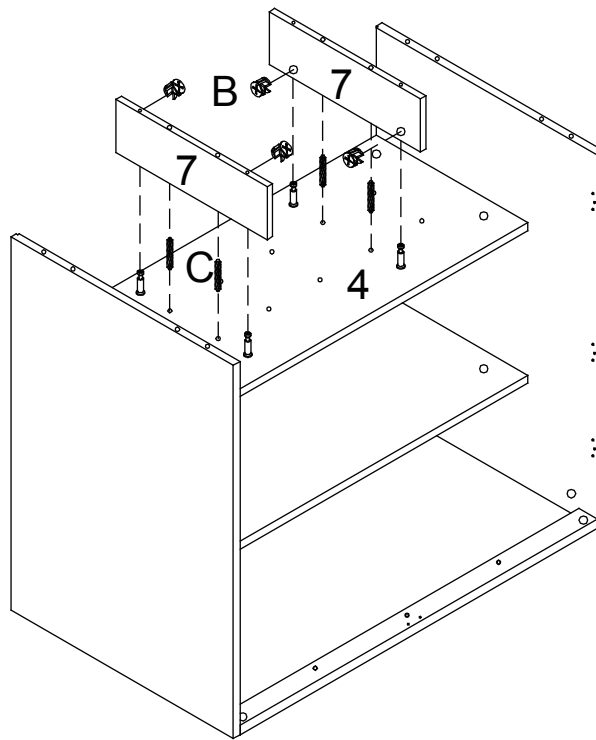

B		4 pcs
C		4 pcs



- Insert Wood Dowel (C) to Divide Panel (7) as shown.
- Attach Divide Panel (7) to Lower Shelf (4) via Cam-bolts on (4) and Wood dowels.
- Insert Cam-lock (B) into the holes on (7) then turn clockwise to lock onto Cam-bolt.

## STEP 9

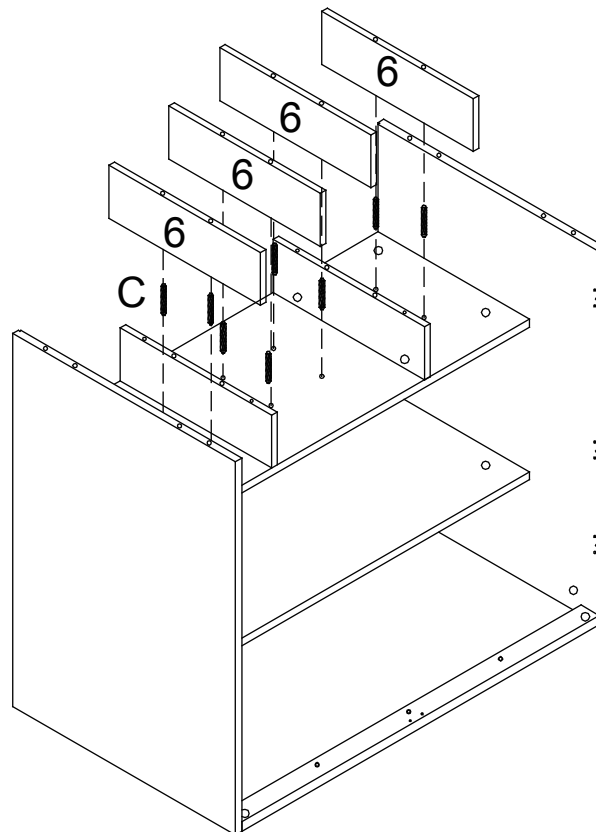

C		8 pcs
---	---	-------

- Insert Wood Dowel (C) to Divide Panel (6) as shown.
- Attach Divide Panel (6) to Lower Shelf (4) via Wood dowels.

# STEP 10

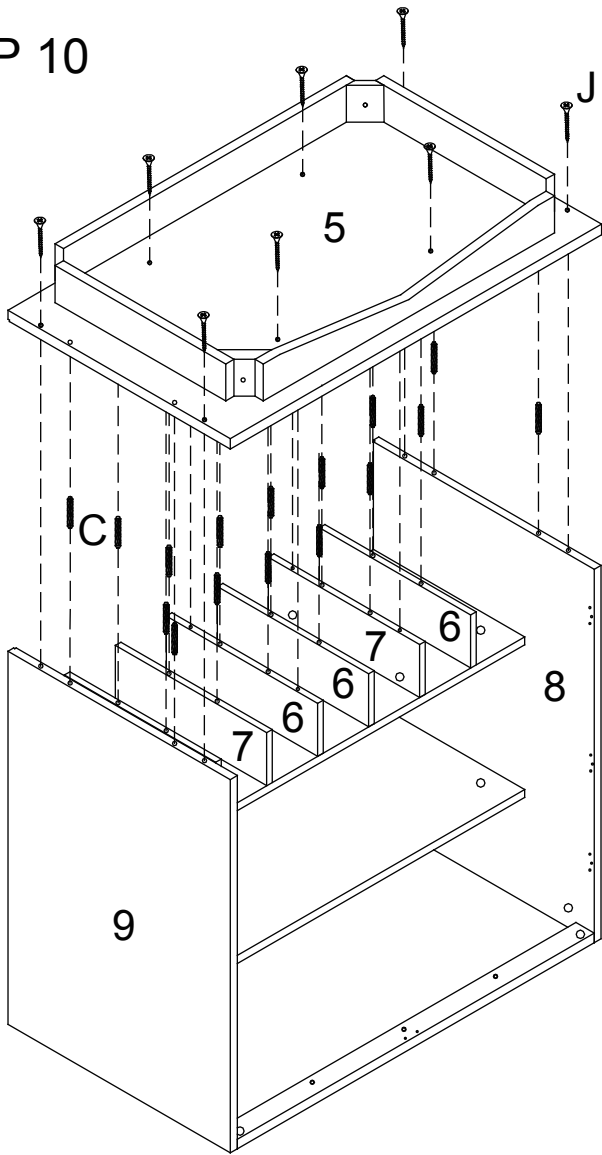

C		16 pcs
J		8 pcs



- Insert Wood Dowel (C) to Panel (6, 7, 8 & 9) as shown.
- Attach Bottom Base (5) to (6, 7, 8 & 9) via Wood dowels.
- Insert Screw (J) and tighten all screws.

# STEP 11

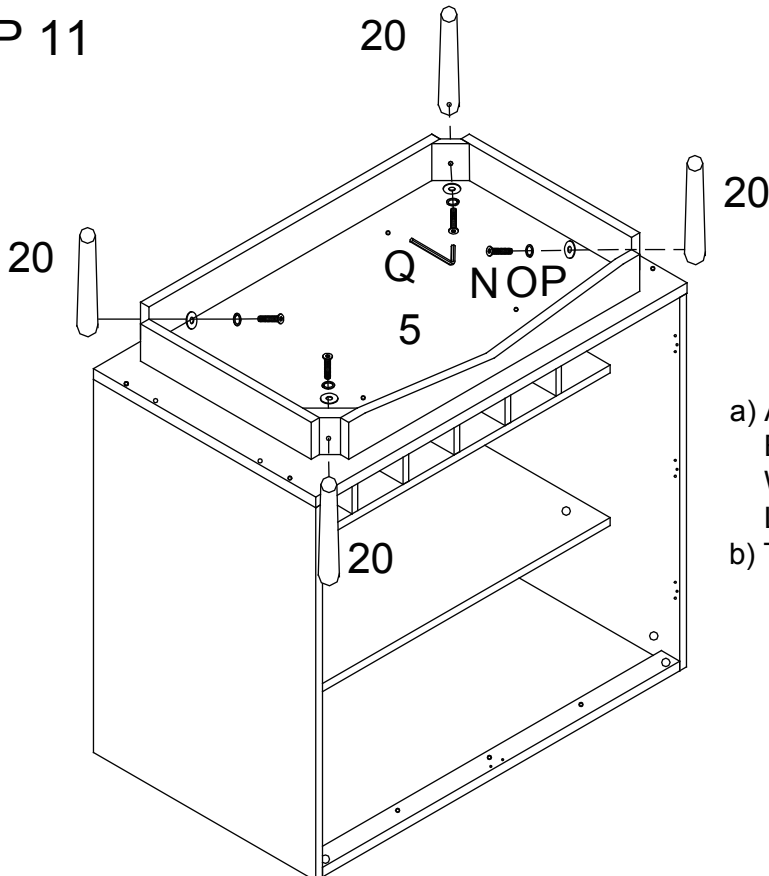



N		4 pcs
O		4 pcs
P		4 pcs
Q		1 pc

- Attach Leg (20) to corner block of Bottom Base (5) use Bolt (N), fitting with Spring Washer (O) and Flat Washer (P) to fasten Leg to corner block of (5).
- Tighten Bolt (N) with Allen Wrench (Q).

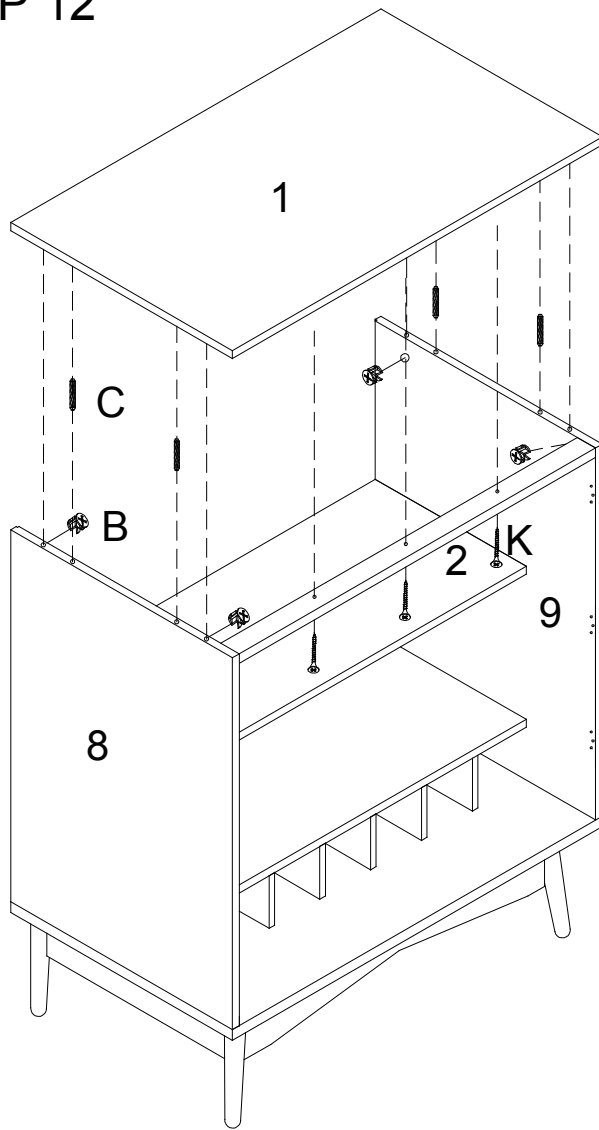
## STEP 12



B		4 pcs
C		4 pcs
K		3 pcs

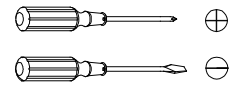

- Insert Wood Dowel (C) to Panel (8 & 9) as shown.
- Attach Top Panel (1) from STEP 1 to (8 & 9) via Cam-bolts on (1) and Wood dowels.
- Insert Cam-lock (B) into the holes on (8 & 9) then turn clockwise to lock onto Cam-bolt.
- Fasten Connect Bar (2) to (1) with Screw (K).

## STEP 13

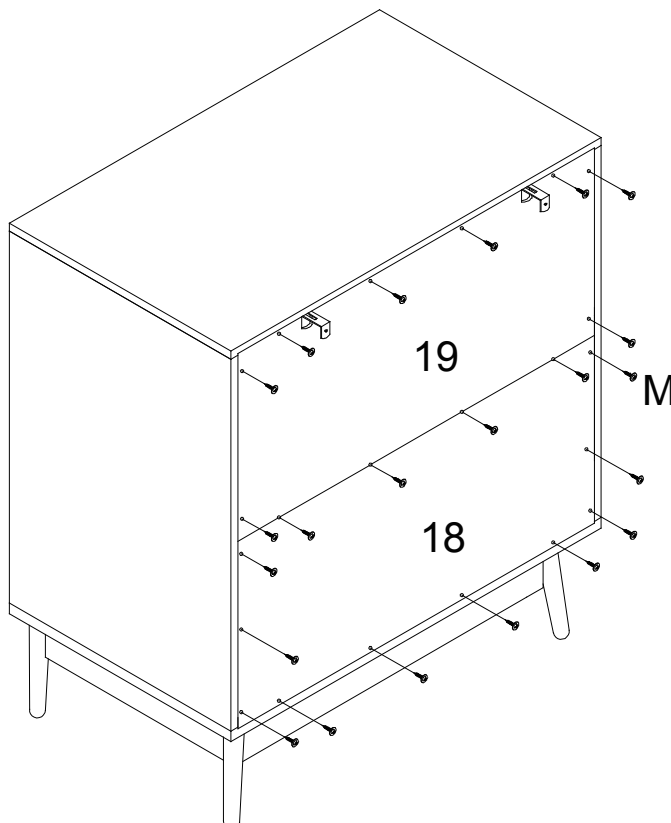



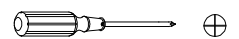

M		22 pcs
---	---	--------



Attach Back Panel (18 & 19) using Screw (M) - follow the screw lay-out as shown.

# STEP 14

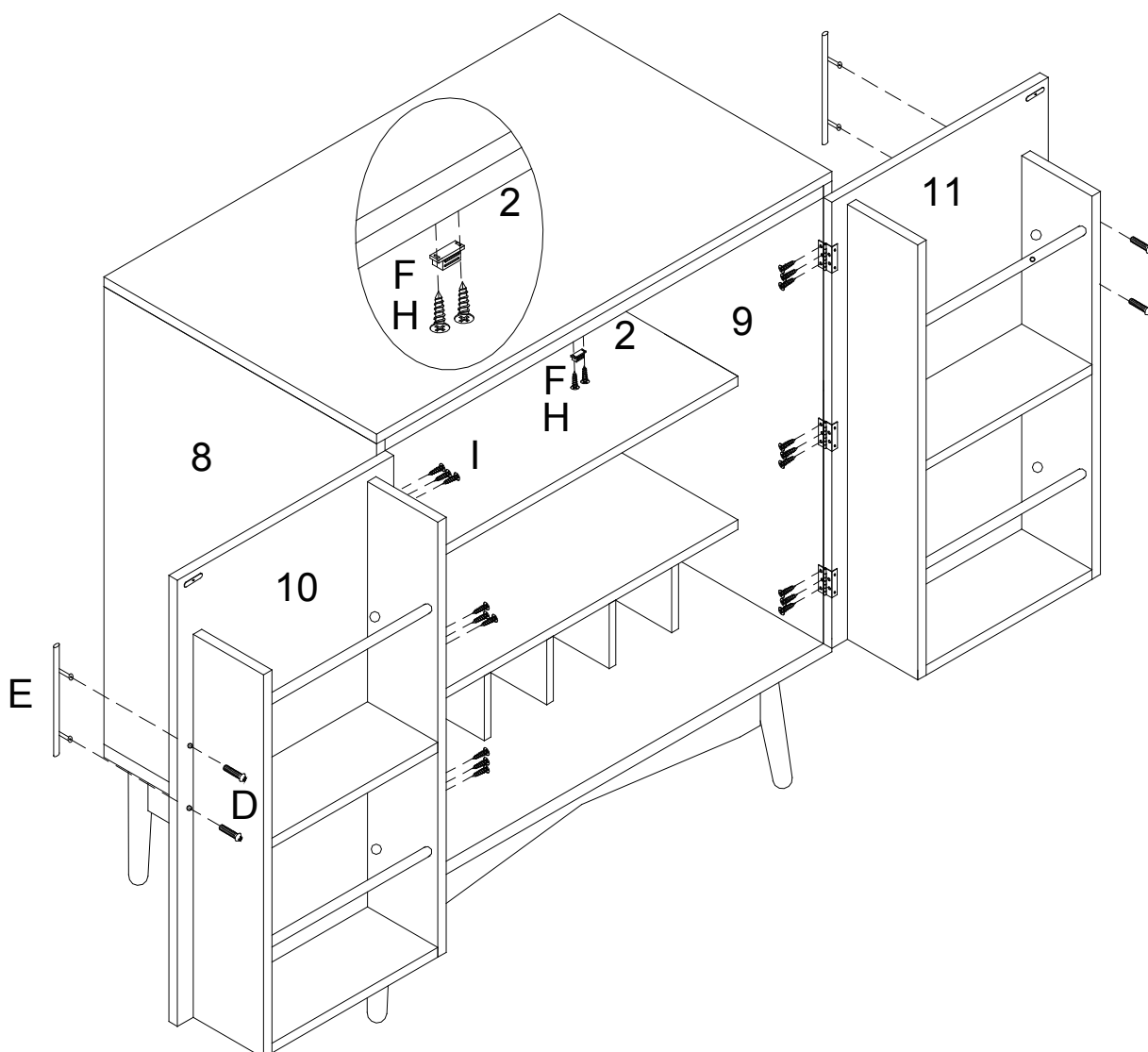
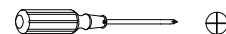

- a) Attach Magnetic Catch (F) to Connect Bar (2) using Screw (H).
- b) Locate pilot holes for hinge on Side Panels 8 & 9. Fasten wing of hinge on Door (10 & 11) to Side Panel (8 & 9) using Screw (I).
- c) Affix Handle (E) to Door (10 & 11) using Handle Bolt (D).

D		4 pcs
E		2 pcs
F		1 pc
H		2 pcs
I		18 pcs



The assembly of the cabinet is complete.

# STEP 15

J		2 pcs
R		2 pcs

 ⊕

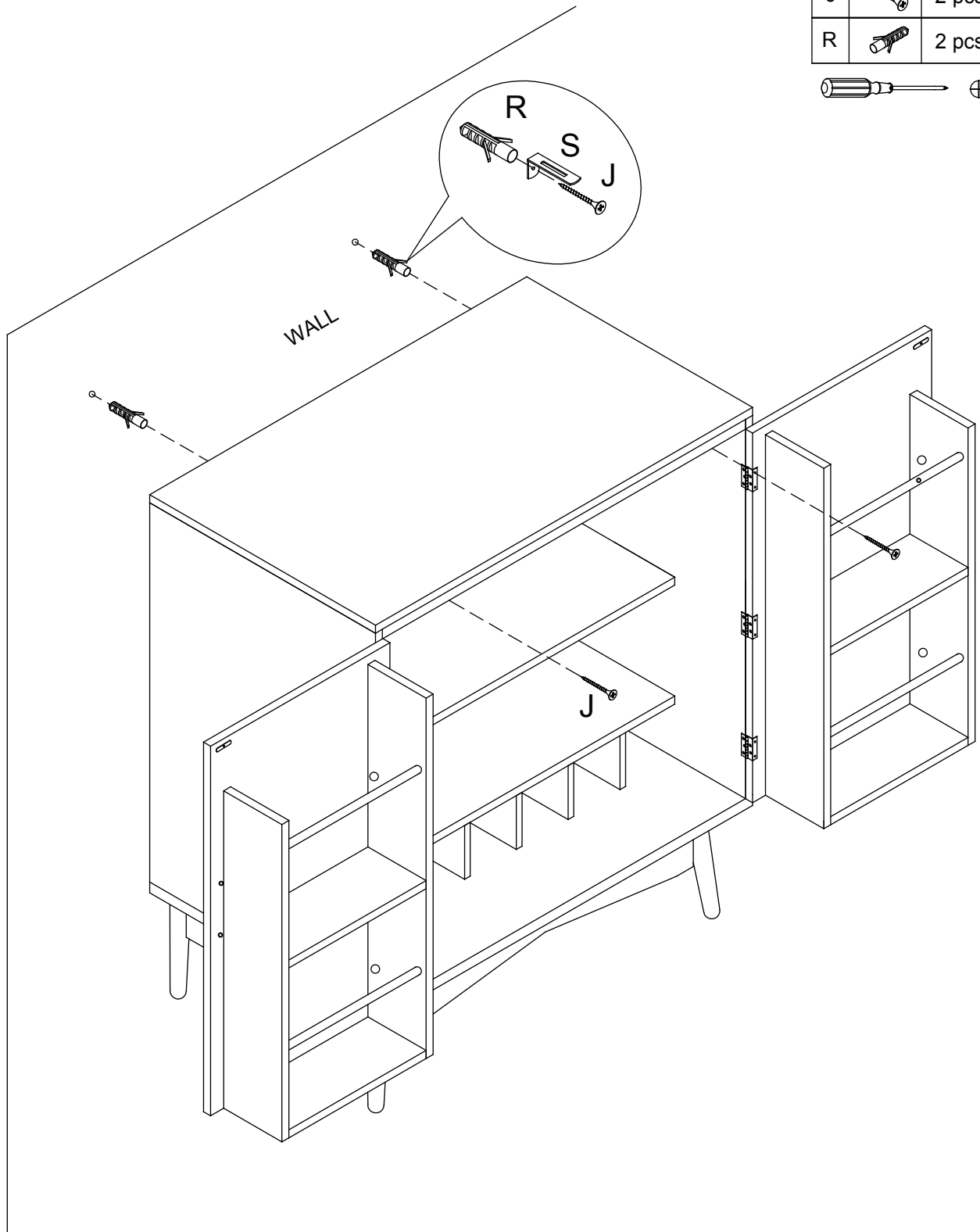

- Drill two holes in the dry wall as per the length and diameter of Plastic Anchor (R) and the distance between the holes and the height need to be the same as the screw holes on Bracket (S).
- Press Plastic wall anchor (R) into the 2 drilled holes. Ensure that the anchor fits securely in the wall.
- Drive Screw (J) through the screw hole on Bracket (S) into the screw hole on (R) to secure the Sideboard to the wall.

The assembly of the cabinet is complete.