

ASSEMBLY INSTRUCTIONS

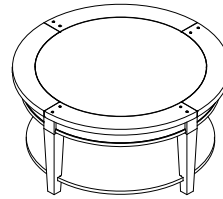

038-911

TOOLS REQUIRED:

Allen Wrench (Provided, Part F)

BEFORE YOU START:

1. Check the parts against the parts list to make sure all items are present.
2. Assemble your furniture on a soft, flat surface to avoid scratching the finish.
3. **CAUTION:** Do not over tighten screws, nuts or bolts during assembly.
4. Your furniture may require occasional tightening.

INSTRUCTIONS:

1. Turn the table upside down on a clean soft surface.
2. Attach three legs to the table using the Bolt (B), Lock Washer (D), Flat Washer (E) and the Allen Wrench (F). As shown in Figure 1.
3. Attach bottom panel to the legs with 'L' Metal Basket (A) using the Bolt (C), Lock Washer (D), Flat Washer (E) and the Allen Wrench (F). As shown in Figure 2.
4. Repeat step 2, 3 for the last leg.
5. Tighten all bolts before using the table.

Figure 1

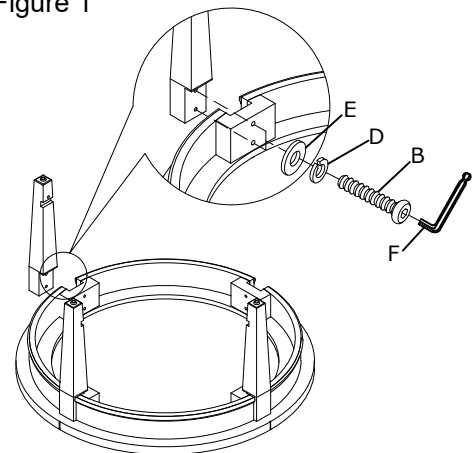
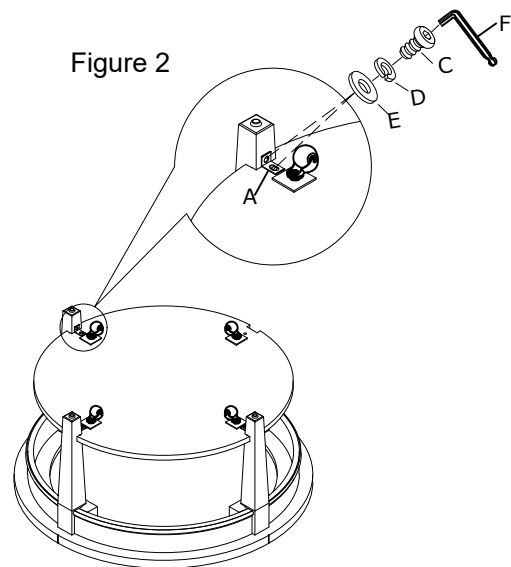







Figure 2



No.	Hardware List	Q'ty
A	 "L" Metal Basket	4pcs
B	 Bolt Ø1/4 "x2-1/8 "	8pcs
C	 Bolt Ø1/4 "x5/8 "	8pcs
D	 Lock Washer Ø1/4"	16pcs
E	 Flat Washer Ø1/4"*16mm	16pcs
F	 Allen Wrench 4MM	1pc