

IMPORTANT INSTRUCTIONS AND OPERATING MANUAL

LP GAS GRILL

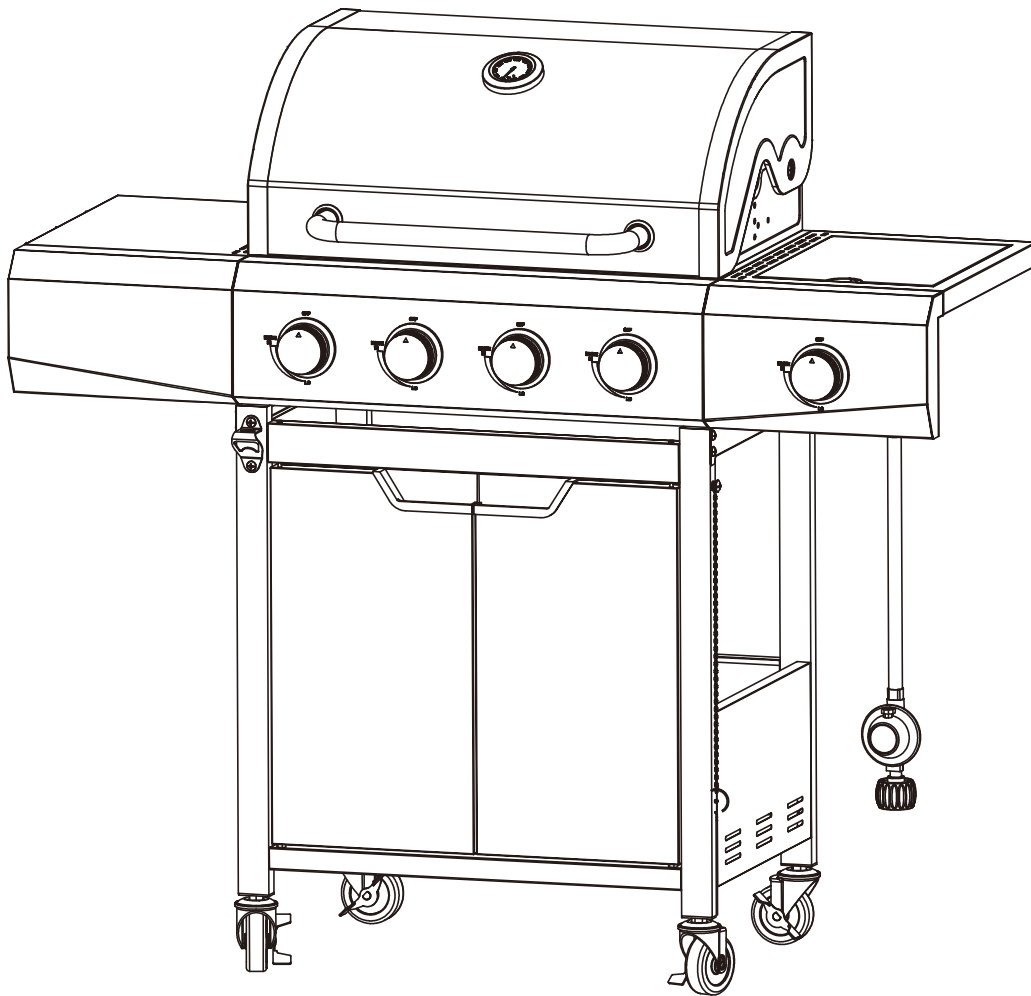

Model: GA5006

✉ vipservice202401@163.com

TABLE OF CONTENTS

Safety Information	3
Package Contents	5
Hardware Contents	9
Preparation	9
Assembly Instructions	10
Operation Instructions	21
Care and Maintenance	26
Troubleshooting	29

Assembler/Installer: This manual contains important information that is necessary for the proper assembly and safe use of this appliance. Read and follow all warnings and instructions before assembling and using this appliance. **Leave these instructions with the consumer.**

Consumer/User: Follow all warnings and instructions when using this appliance.
Retain these instructions for future reference.

DANGER

If you smell gas:

- 1. Cut off gas to the appliance.**
- 2. Extinguish any open flame.**
- 3. Open lid.**
- 4. If odor continues, keep away from the appliance and immediately call your local fire department.**

WARNING

- 1. Do not store or use gasoline or other flammable liquids or vapors close to this or any other appliance.**
- 2. An LP (liquid propane) cylinder not connected for use shall not be stored close to this or any other appliance.**
- 3. This grill is only for outdoor using and shall not be used in a building, garage, under overhangs or any other enclosed area.**
- 4. Do not leave a lit grill unattended. Keep children and pets away from the grill at all times.**



SAFETY INFORMATION

Thank you for purchasing this product!

DANGER

- Do not use in an explosive atmosphere. Keep grill area clear and free from combustible materials, gasoline and other flammable vapors and liquids.

CALIFORNIA PROPOSITION 65

Fuels used in gas or oil fired appliances and the products of combustion of such fuels contain chemicals, including Benzene, known to the State of California to cause cancer, birth defects or other reproductive harm. This product contains chemicals, including lead and lead compounds, known to the State of California to cause cancer, birth defects or other reproductive harm. ***Wash hands after handling.***

CAUTION

- Never use charcoal or lighter fluid with the grill.
- Do not use gasoline, kerosene or alcohol for lighting.
- The LP gas cylinder used with this appliance must be:
 - (a) Constructed and marked in accordance with the Specifications for LP-Gas Cylinders of the U.S. Department of Transportation (D.O.T.) or the National Standard of Canada, CAN/CSA-B339, Cylinders, Spheres and Tubes for Transportation of Dangerous Goods; and Commission, as applicable; and
 - (b) Provided with a listed overfilling prevention device.
 - (c) Provided with a cylinder connection device compatible with the connector for outdoor cooking appliances. This grill is not intended to be used in or installed on recreational vehicles and/or boats.
- Never keep a filled container in a hot car or car trunk. Heat will cause the gas pressure to increase, may open the relief valve and leak the gas.
- Always open grill lid slowly and carefully as heat and steam trapped within the grill can hurt you severely.

SAFETY INFORMATION

WARNING

- Do not place the grill under overhead combustible construction or awnings. Minimum clearance from sides and back of unit to combustible construction, 36 inches (915.0mm) from sides and back.

NOTE: The installation must conform with local codes or, in the absence of local codes, with either the National Fuel Gas Code, ANSI Z223.1/NFPA 54, Natural Gas and Propane Installation Code, CSA B149.1, or Propane Storage and Handling Code, B149.2.

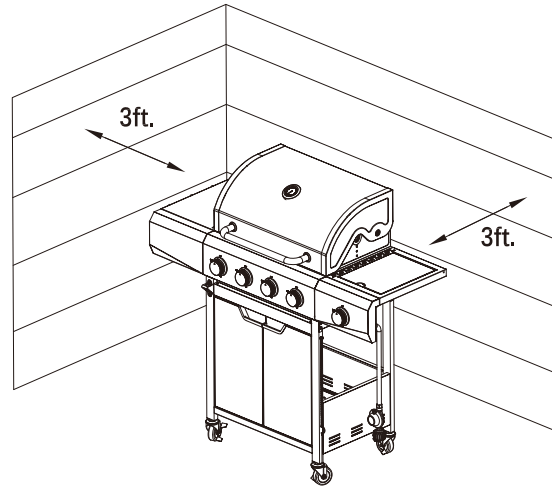



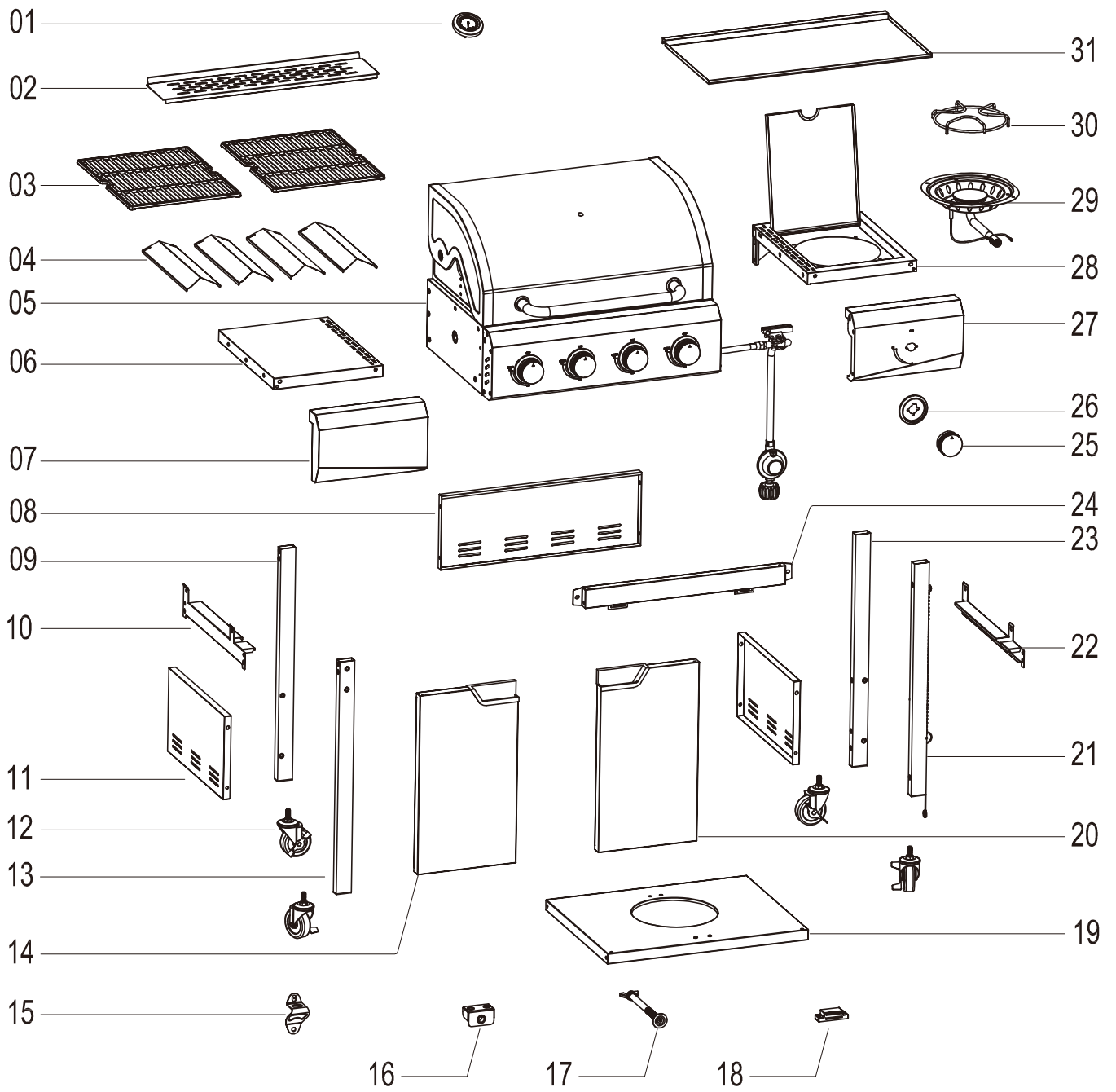

CAUTION

- Do not store or use gasoline or other flammable liquids or vapors close to this or any other appliance.
- An LP cylinder not connected for use shall not be stored close to this or any other appliance.
- This grill is for using with propane gas only (propane cylinder not included).
- Never attempt to attach this grill to the self-contained propane system of a boat, camper trailer, motor home or house.
- Do not attempt to move the grill while it is lit or when it is hot. The casters should be locked down when not moving the grill.
- Do not use the grill unless it is completely assembled and all parts are securely fastened and tightened.
- Keep all combustible items and surfaces at least 36 inches (91.50 cm) away from the grill at all times.
- Do not touch metal parts of grill until it has completely cooled (about 45 minutes) to avoid burns, unless you are wearing protective gear (pot holders, gloves, BBQ mittens, etc...).
- Do not alter this grill in any manner.
- Clean and inspect the hose before each use. If there is obvious abrasion, wear, cuts, or leaks, the hose must be replaced prior to operating the appliance. The replacement hose shall be in accordance with supplier's standard.
- Move gas hoses as far away as possible from the hot surfaces and dripping hot grease.
- Keep the grill's valve compartment, burners and circulating air passages clean. Inspect the grill before each use. Do not obstruct the flow of gas or ventilation air.
- The use of alcohol, prescription or non-prescription drugs may influence the operator's ability to properly assemble or safely operate the grill.
- **Do not leave a lit grill unattended. Keep children and pets away from the grill at all times.**
- Do not place this grill on any type of tabletop surface. The grill should be placed on a flat and level surface.
- Do not use the grill in huge winds.



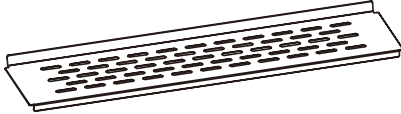
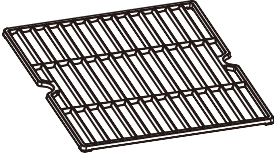
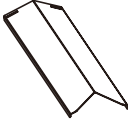
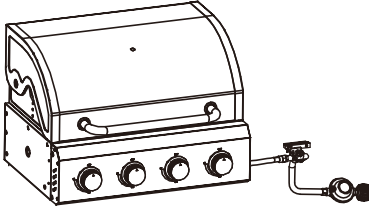
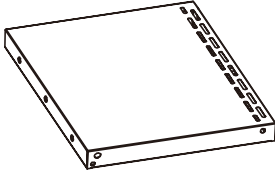

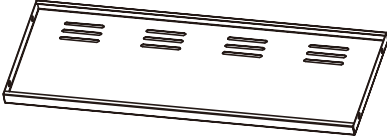
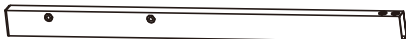



PACKAGE CONTENTS (GA5006)

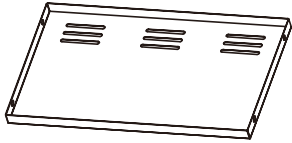

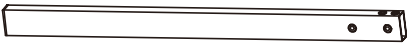
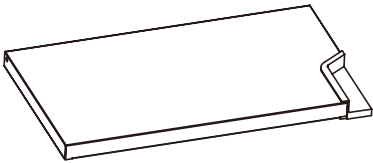



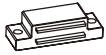
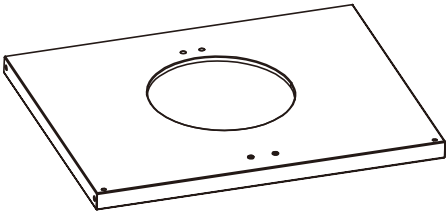
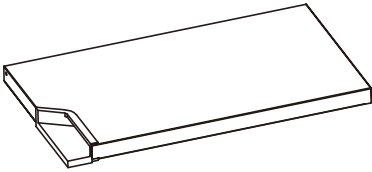

PACKAGE CONTENTS (GA5006)

No.	Parts Name	Parts Diagram	Qty.
1	Thermometer		1
2	Warming Rack		1
3	Cooking Grate		2
4	Heat Tent		4
5	Firebox Assembly		1
6	Left Side Shelf		1
7	Left Fascia		1
8	Rear Cart Panel		1
9	Left Back leg (LB)		1
10	Left brace F/Cart		1

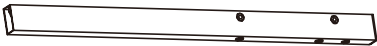



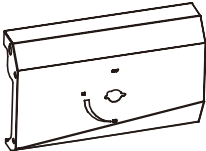
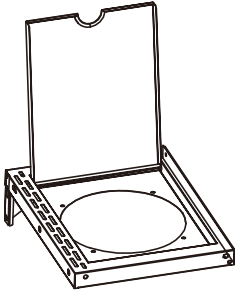

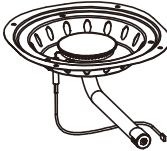
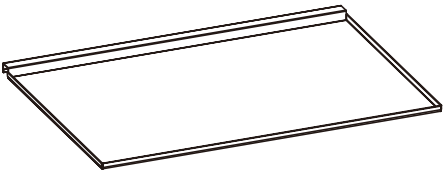

PACKAGE CONTENTS (GA5006)

No.	Parts Name	Parts Diagram	Qty.
11	Side Cart Panel		2
12	Caster, Locking		4
13	Left Front Leg (LF)		1
14	Door Left		1
15	Bottle Opener		1
16	Mounting base F/Adjust screw		1
17	Adjust screw F/LP tank		1
18	Magnet		1
19	Bottom Shelf		1
20	Door Right		1
21	Right Front Leg (RF)		1

PACKAGE CONTENTS (GA5006)

No.	Parts Name	Parts Diagram	Qty.
22	Right Brace F/Cart		1
23	Right Back Leg (RB)		1
24	Front Door Brace		1
25	Control Knob		1
26	Bezel F/Knob		1
27	Right Fascia		1
28	Side Burner Shelf Assembly		1
29	Side Burner Grate		1
30	Side Burner Assembly		1
31	Grease Tray		1

Hardware Contents

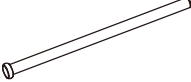
AA	M6x12 Screw		48
BB	M5x10 Screw		13
CC	M4x16 Screw		3
DD	M4x10 Screw		3
EE	Axle Bottom F/Door		2
FF	M5X20 Stepped Screw		3
GG	M6 Nut		3
HH	M5 Nut		5
JJ	Axle Top F/Door		2

PREPARATION

Before beginning assembly of product, make sure all parts are present. Compare parts with package contents list on previous page and hardware contents above. If any part is missing or damaged, do not attempt to assemble the product. Contact customer service for replacement parts.

Estimated Assembly Time: 50 minutes with 2 people.

Tools Required for Assembly and Leak Testing (not included): Phillips screwdriver, Spray bottle, Pliers, Adjustable Wrench

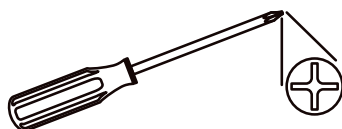

⚠ CAUTION

THIS UNIT IS HEAVY. Two people required for safe assembly.

Two people required for safe assembly. Some parts may contain sharp edges. Wear protective gloves if necessary. Read and follow all safety statements, warnings, assembly instructions and use and care instructions before attempting to assemble and use.

Assembly steps:

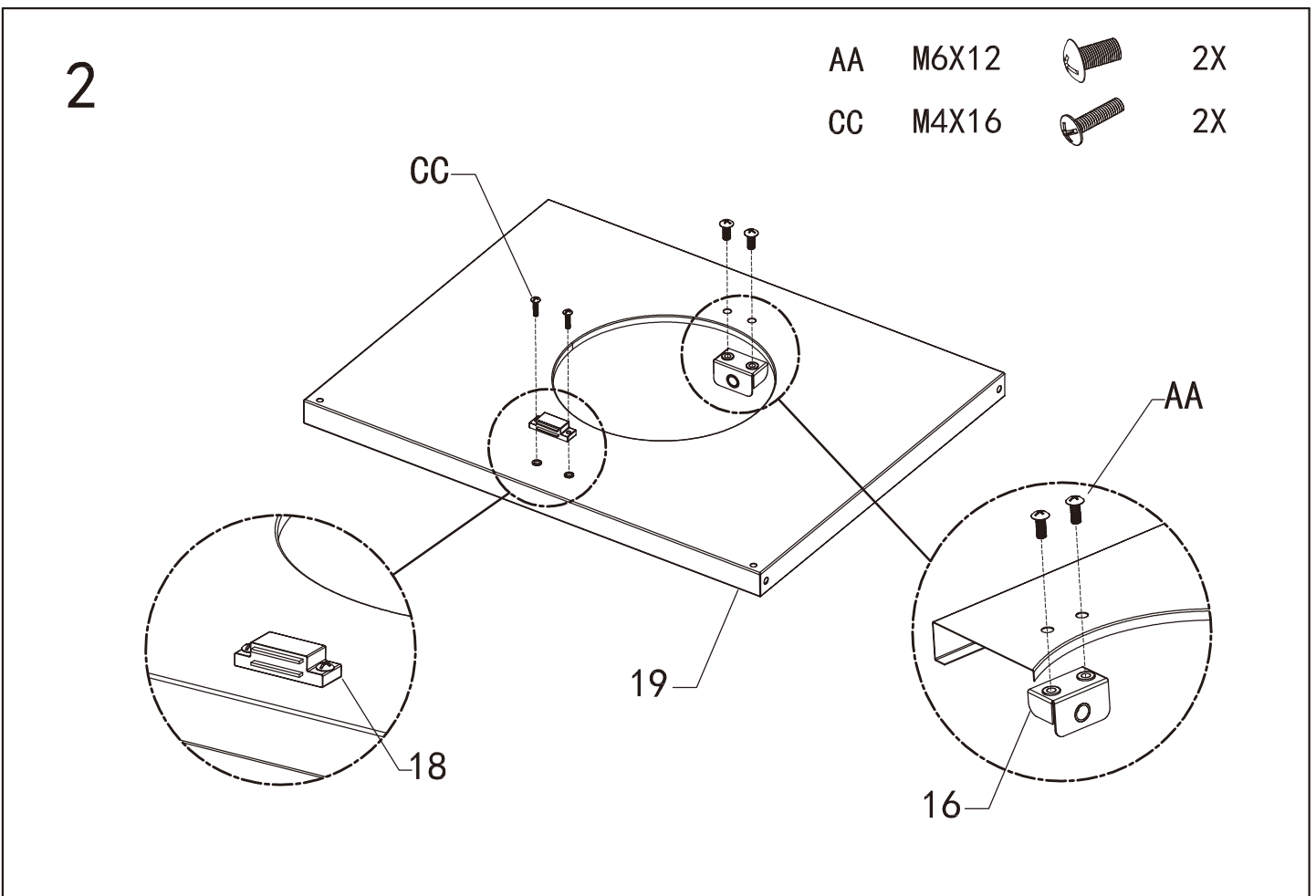
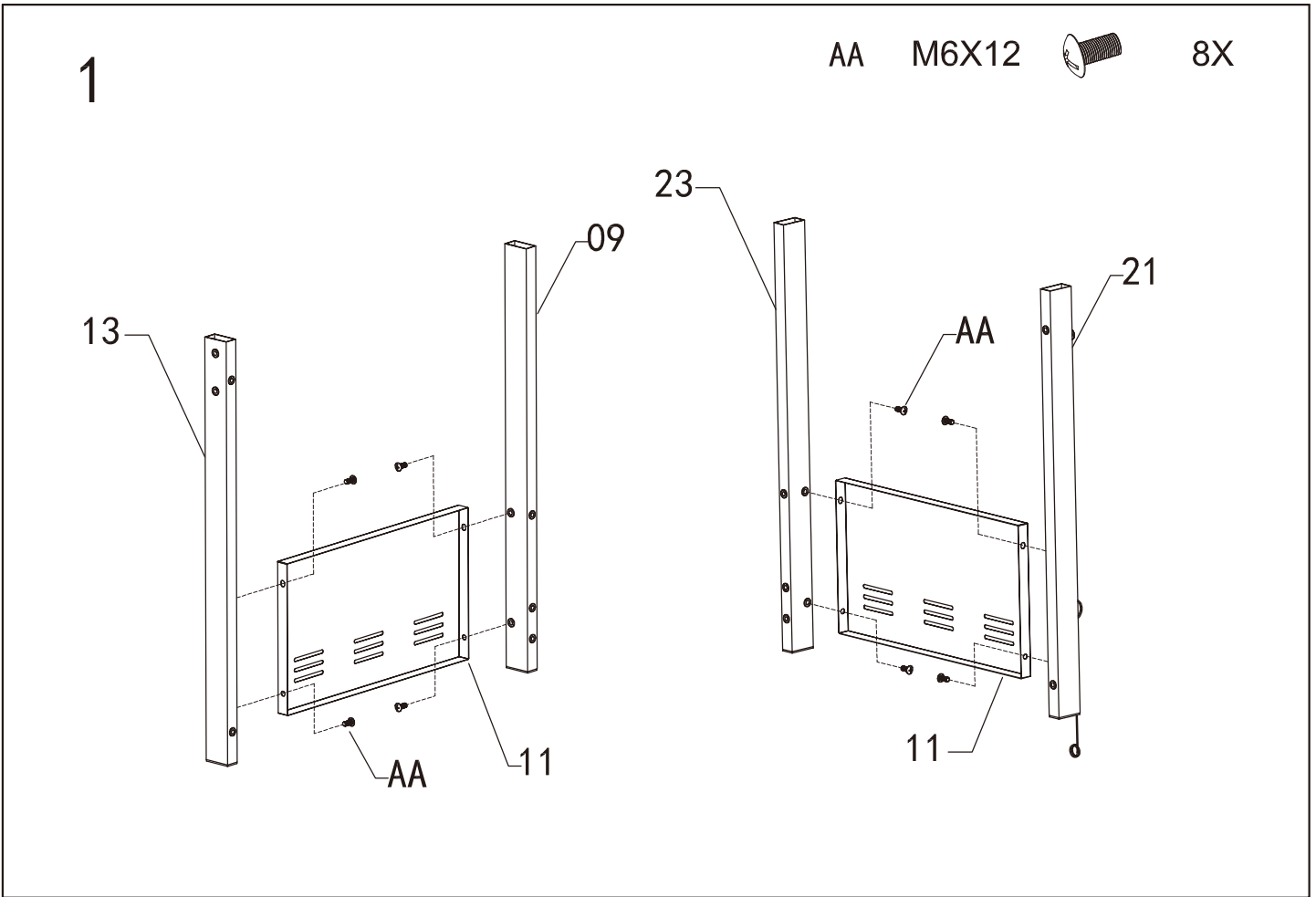

Assembly steps:

3

AA M6X12



4X

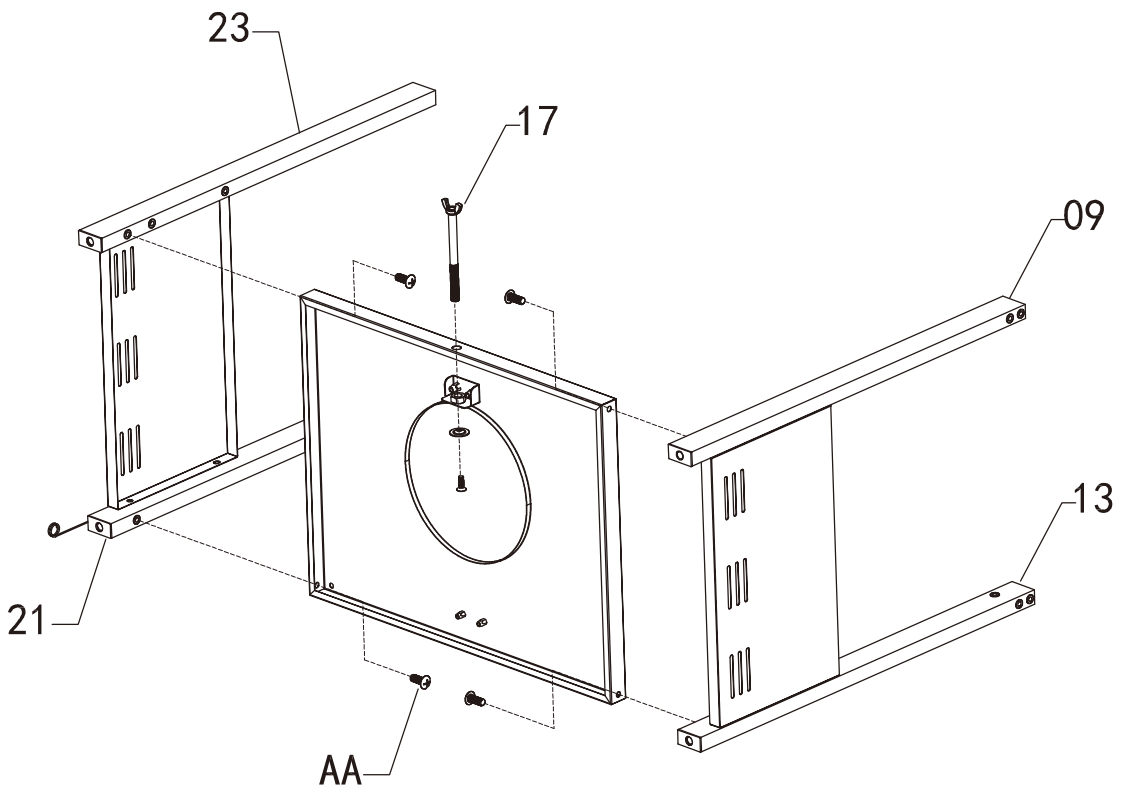

4

AA M6X12



4X

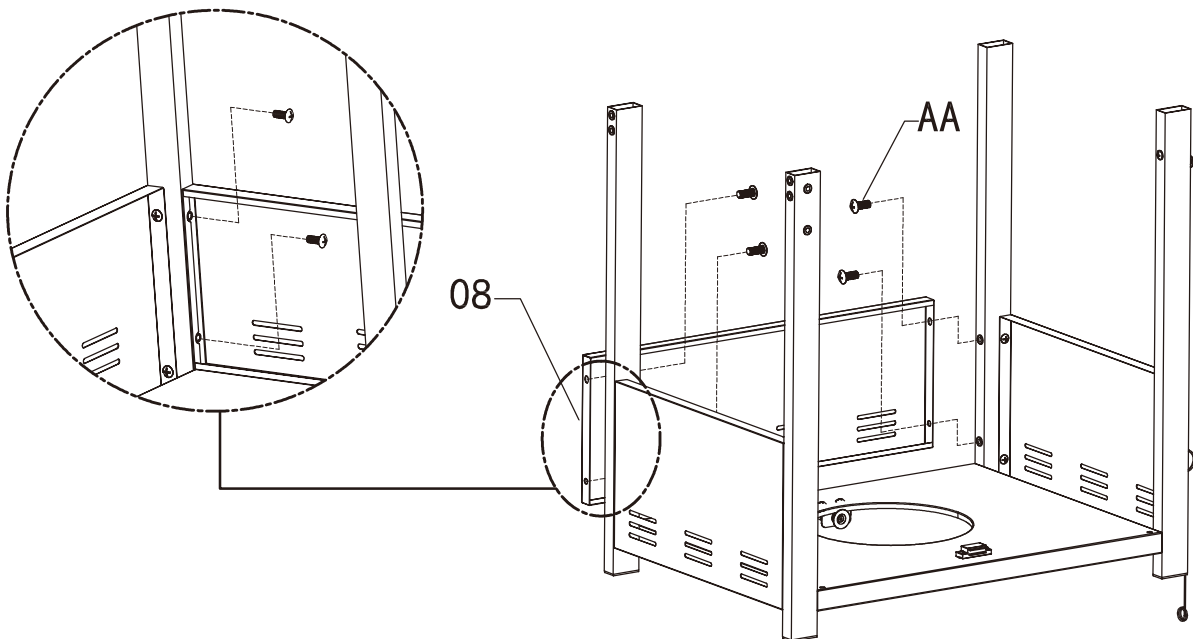

Assembly steps:

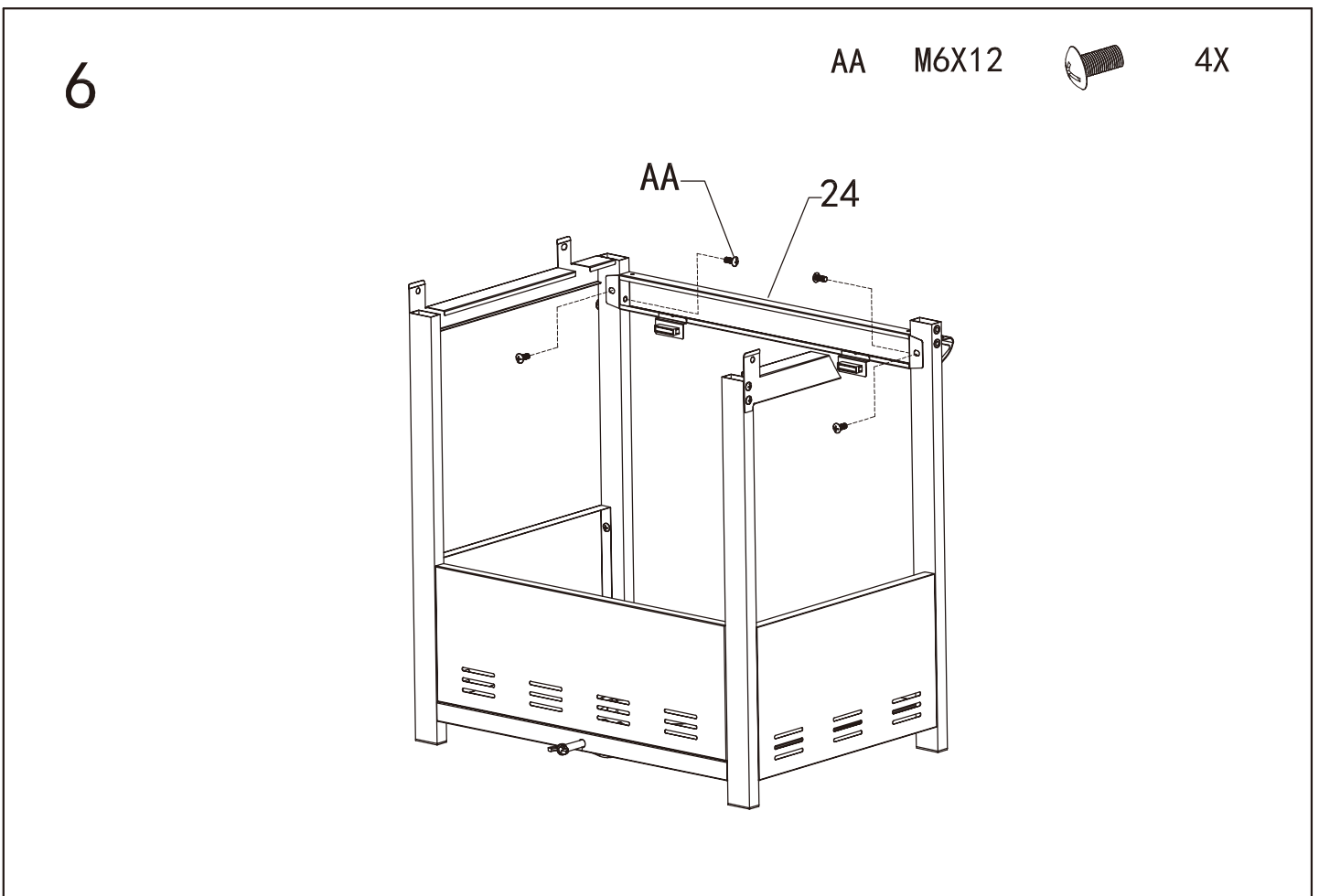
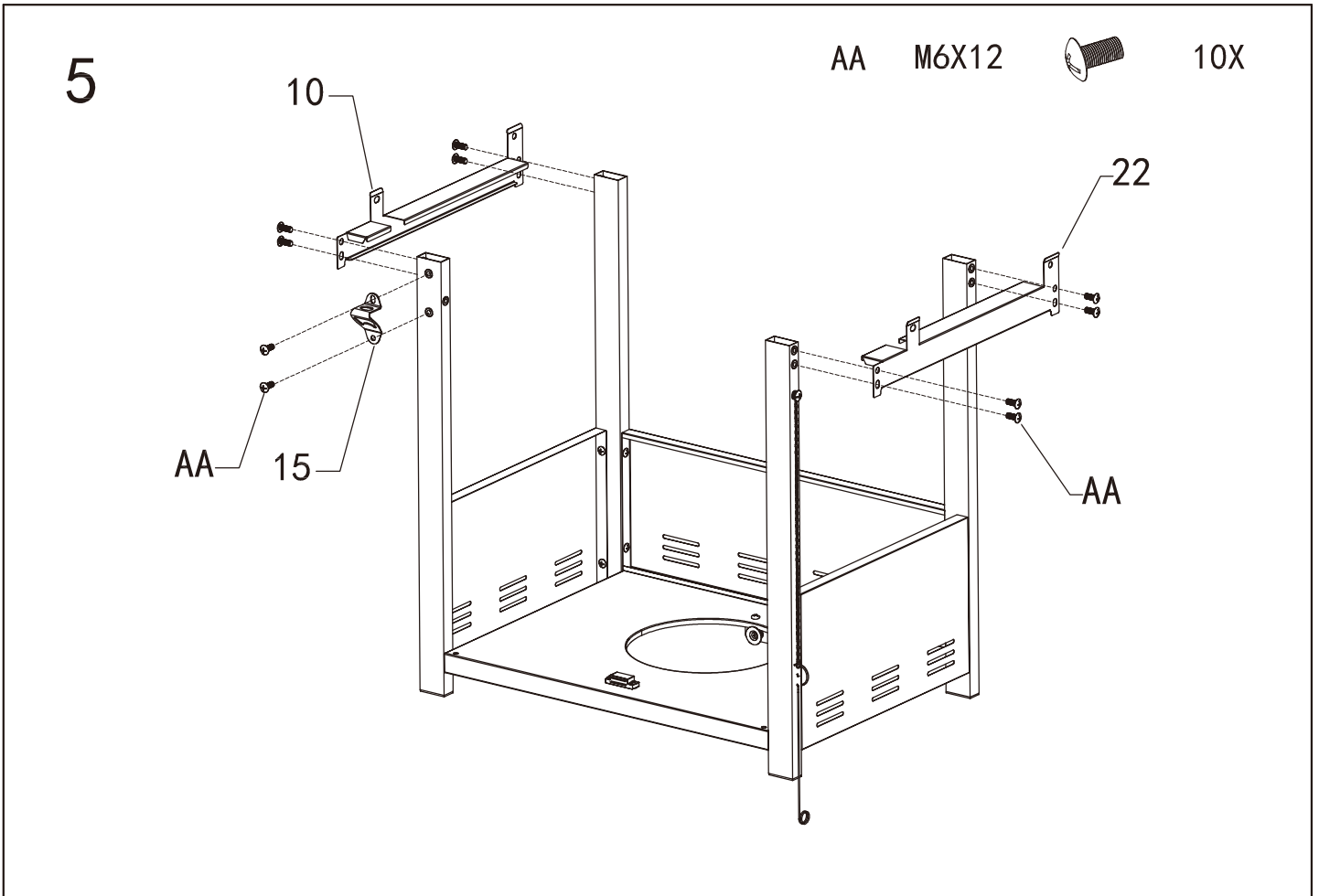

Assembly steps:

7

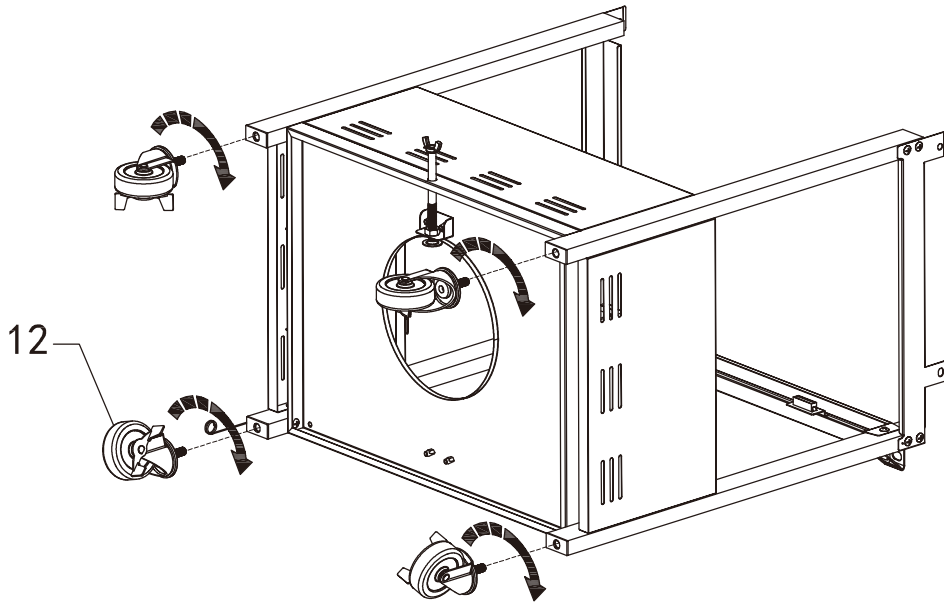

8

- | | | |
|----|--|----|
| EE |  | 2X |
| GG | M6 Nut  | 2X |

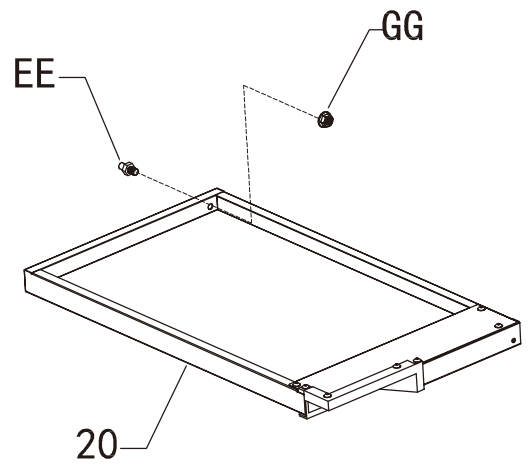
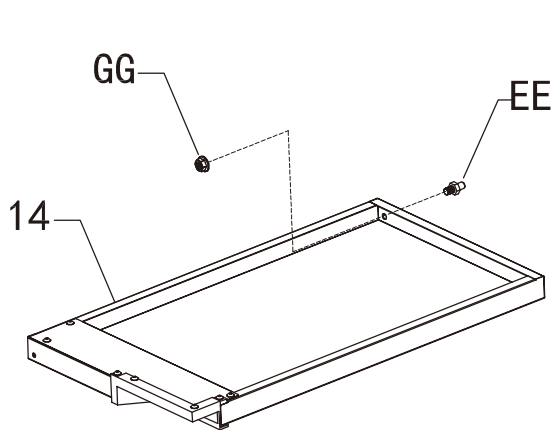

Assembly steps :

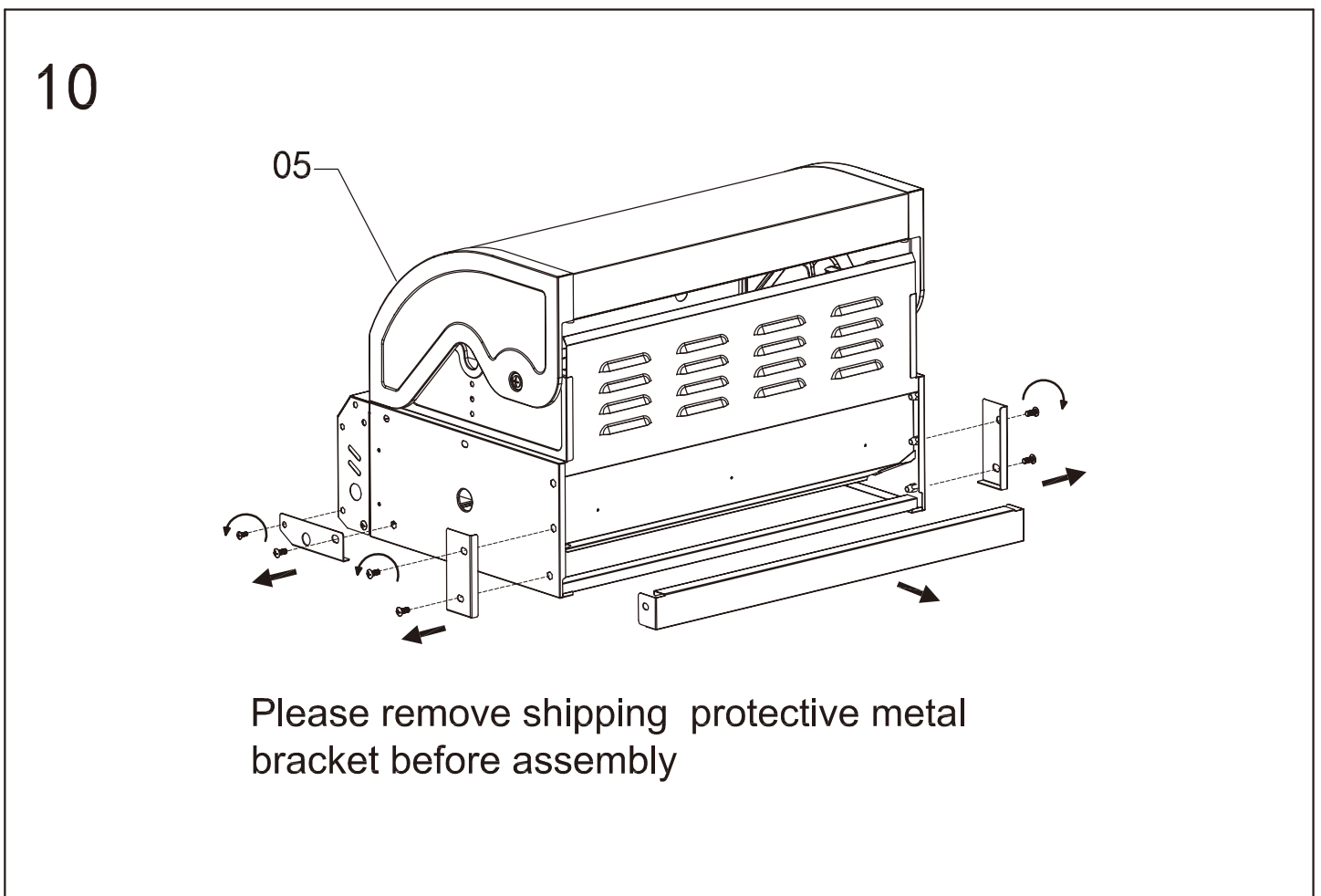
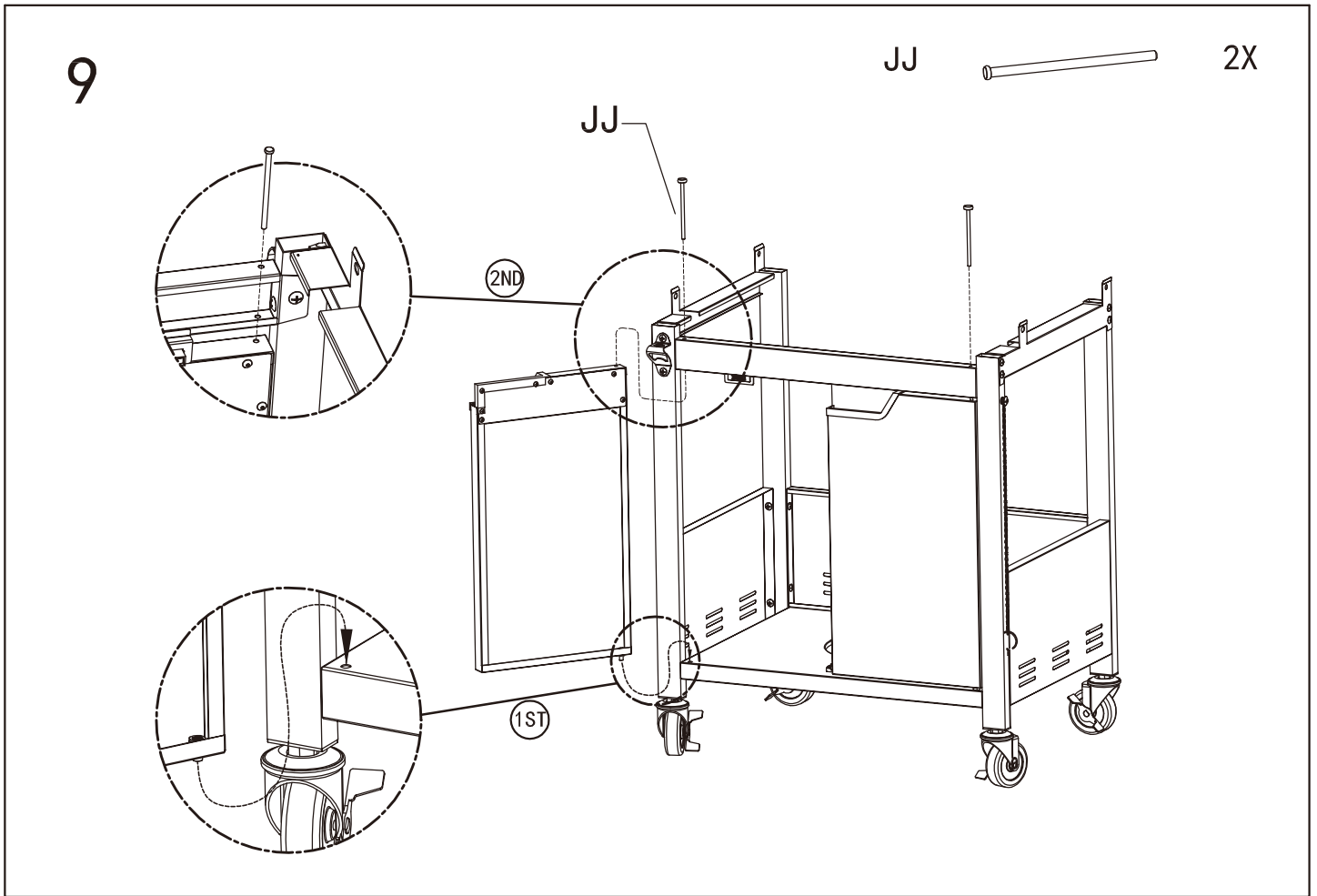

11

AA M6X12 4X

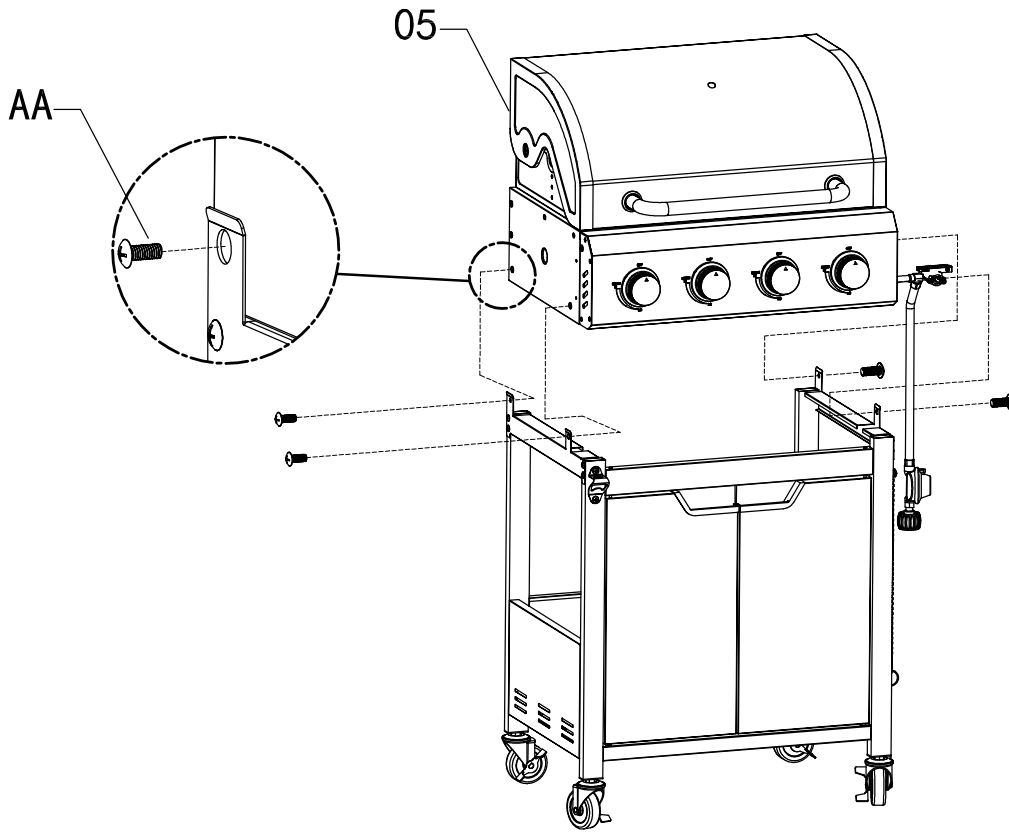

12

AA M6X12 4X
 BB M5X10 2X
 FF 3X

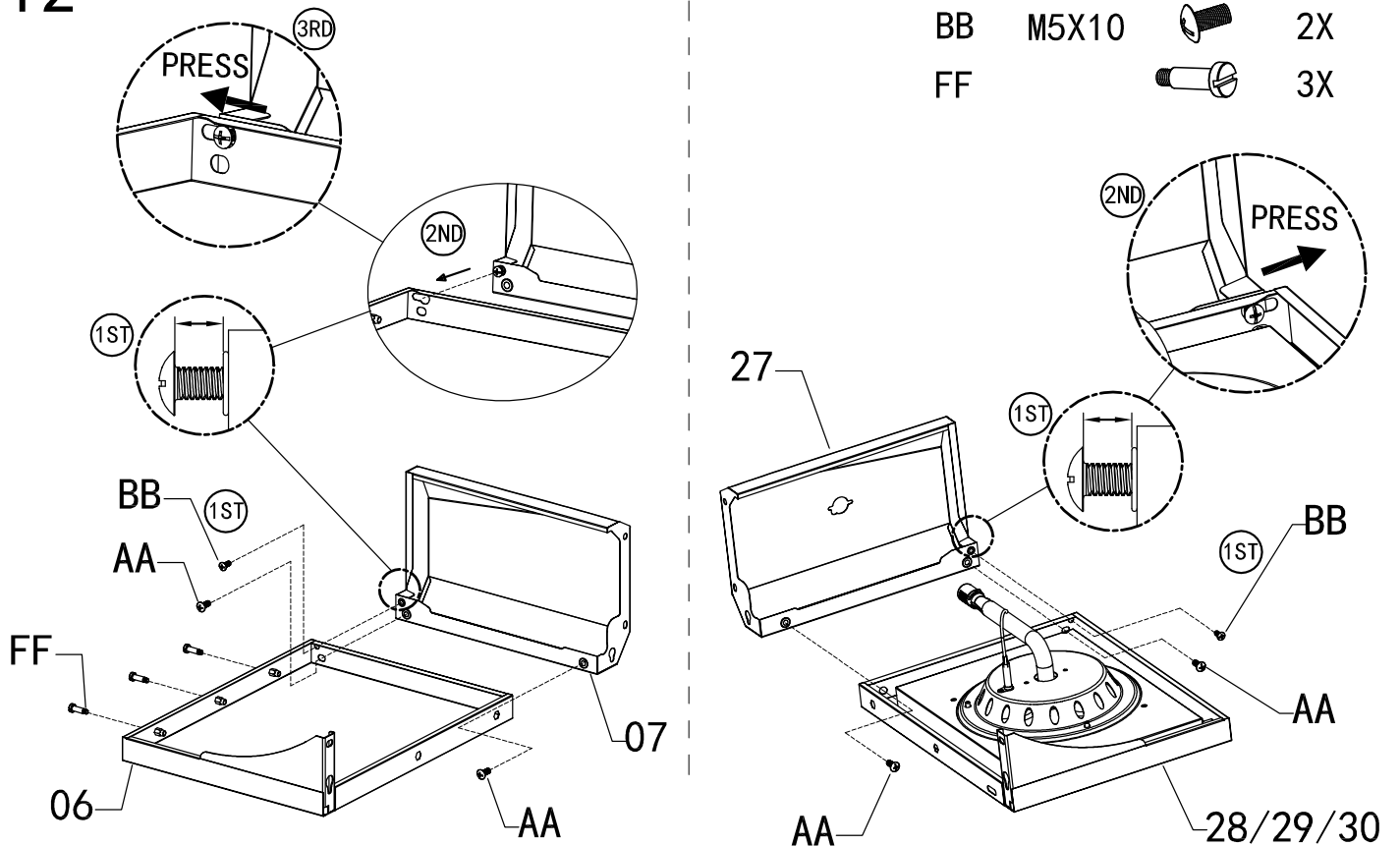

Assembly steps:

13

AA M6X12 4X
 BB M5X10 6X

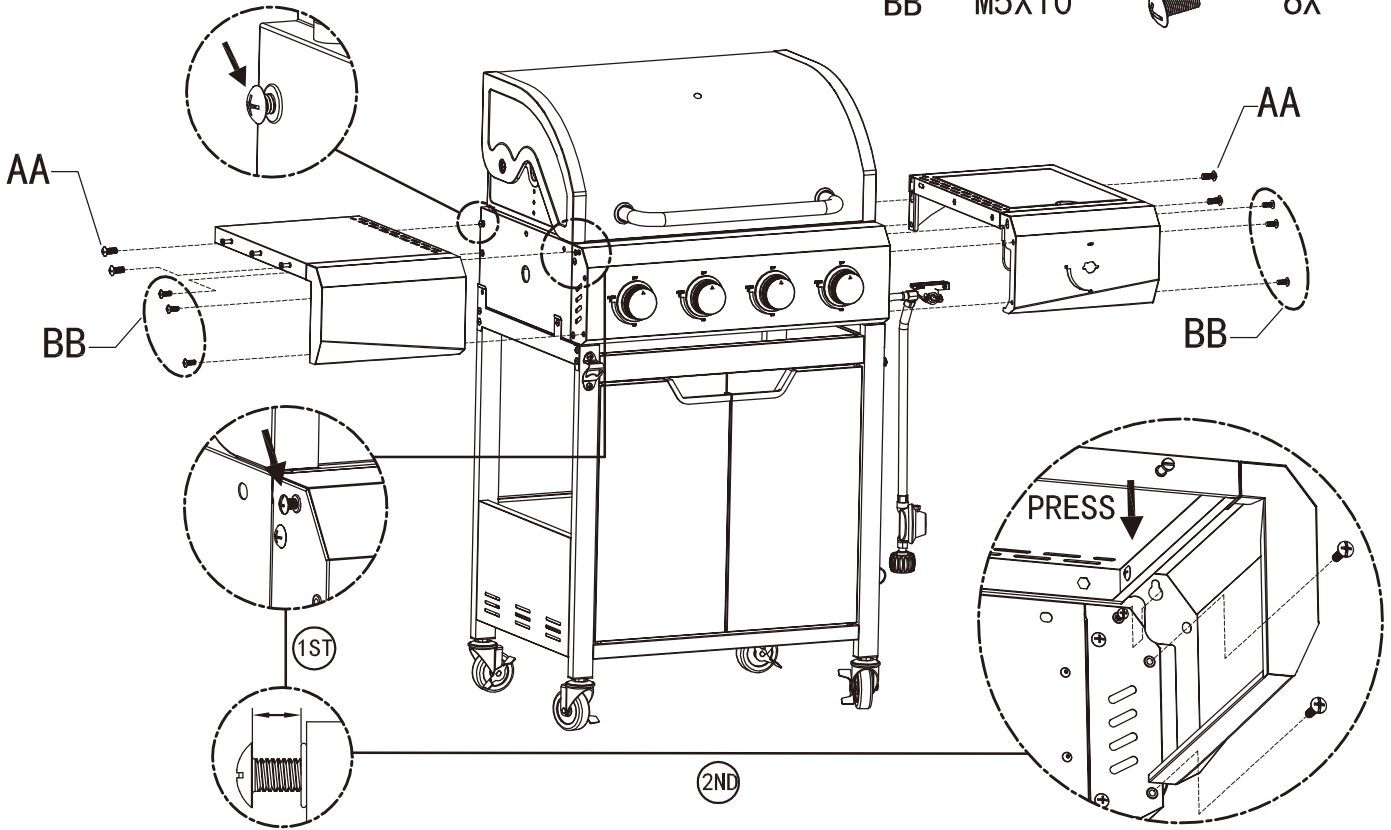

14

AA M6X12 4X

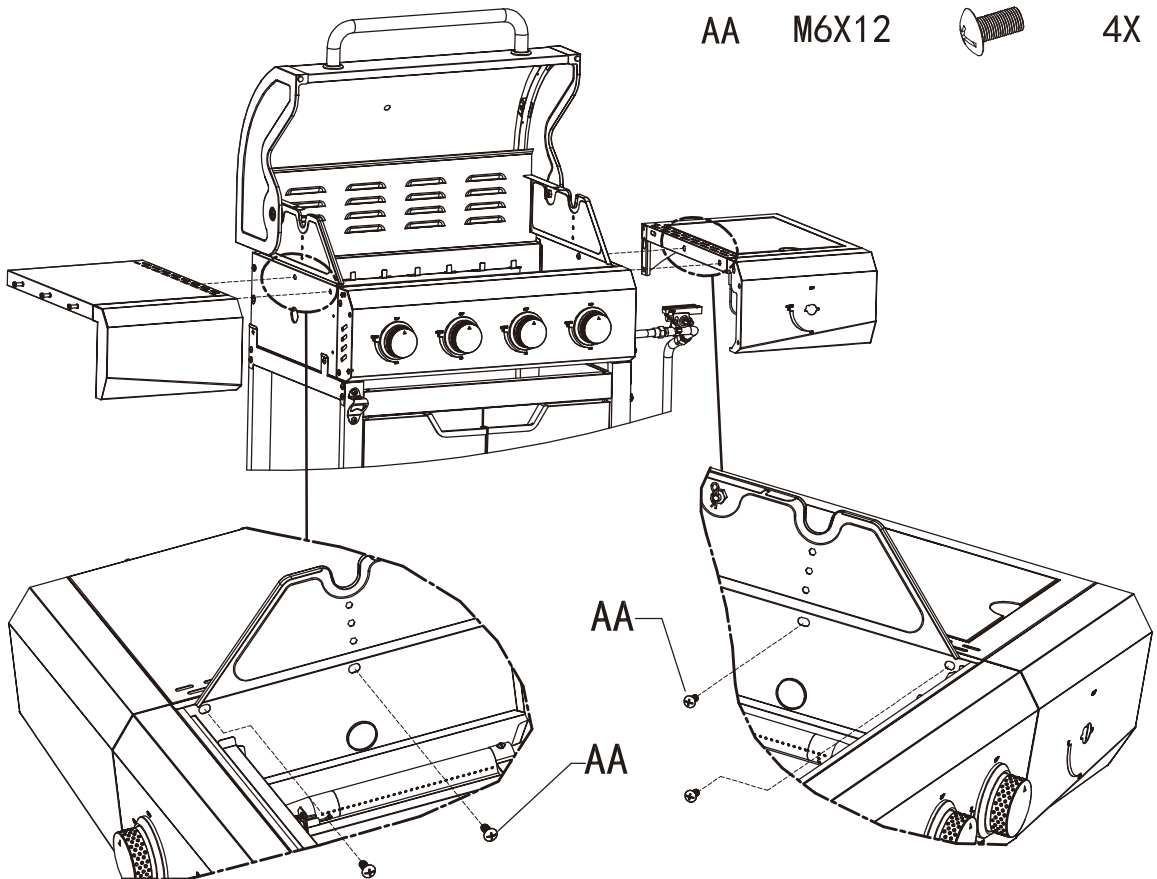

Assembly steps:

15

DD M4X10  2X

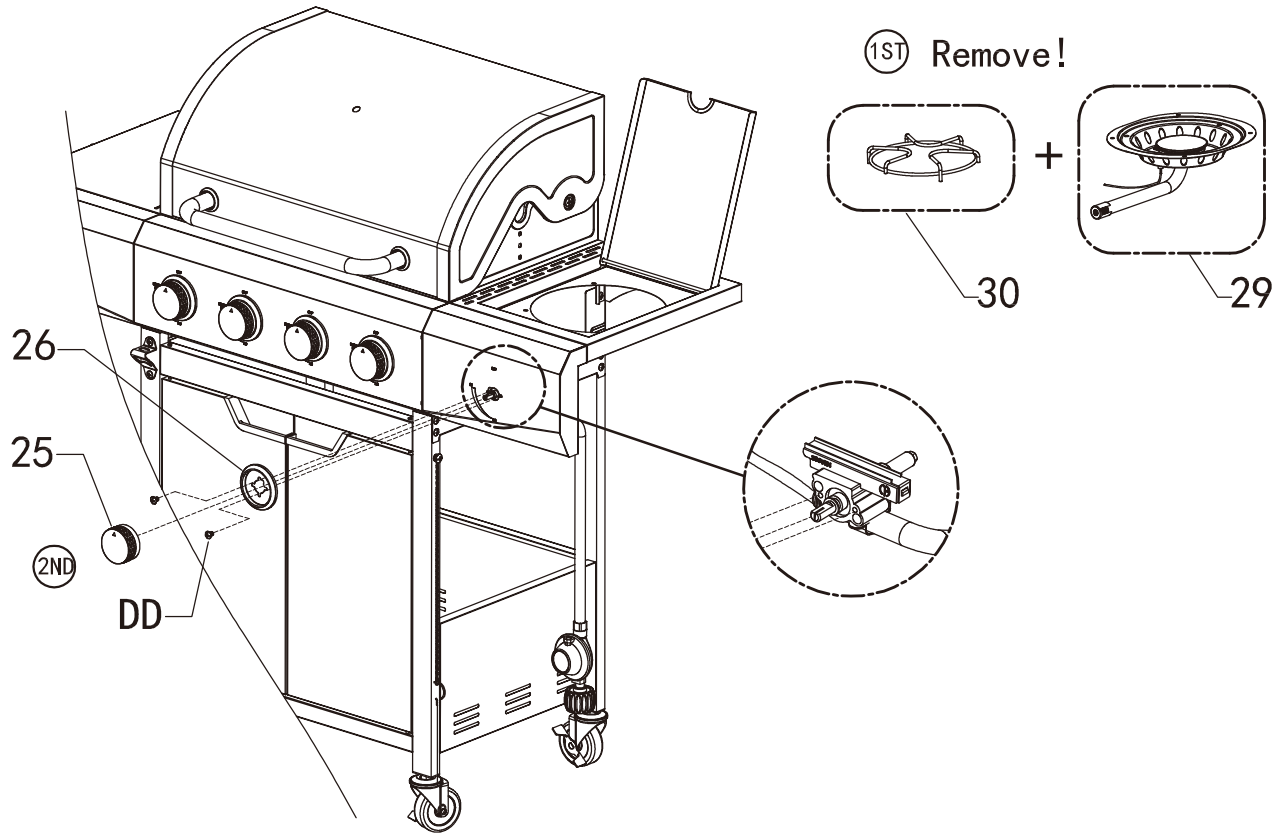

16

BB M5X10  4X

HH M5 Nut  4X

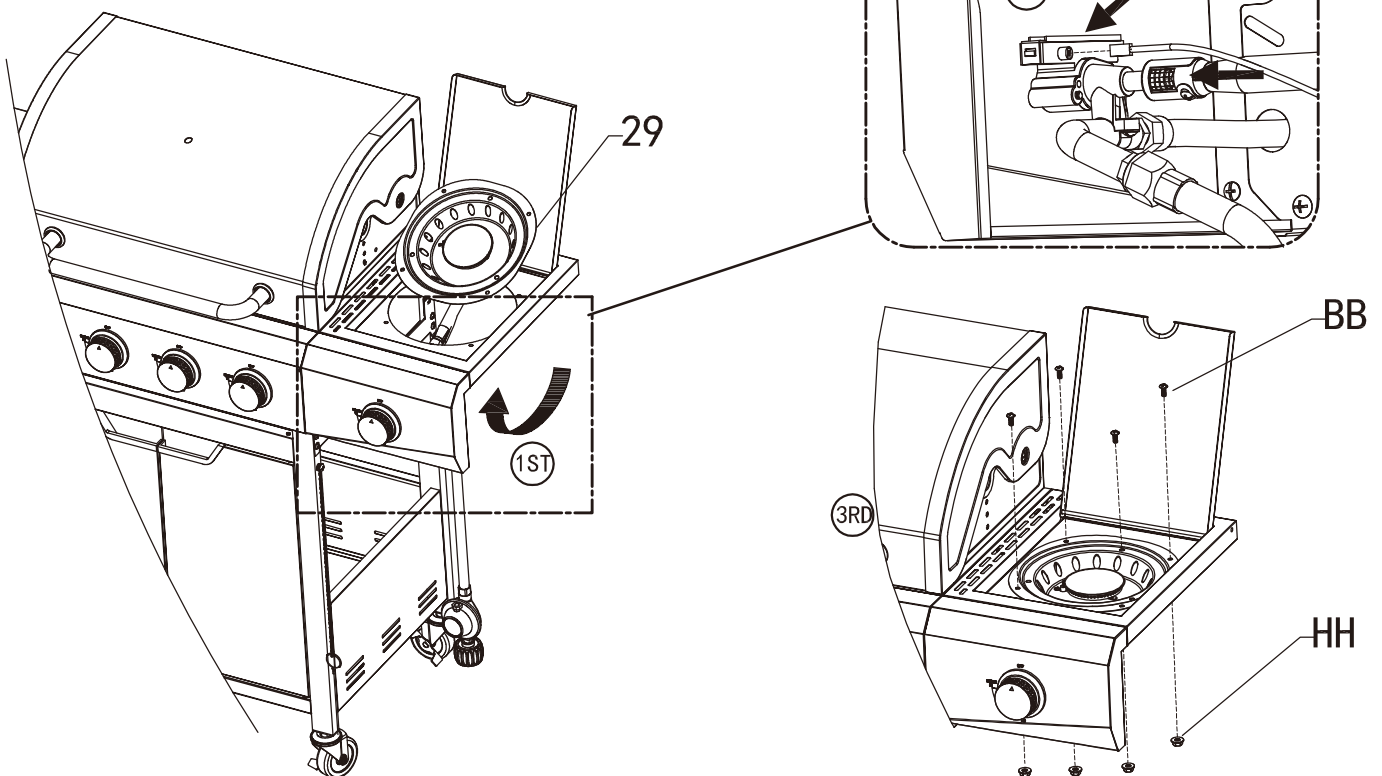

17

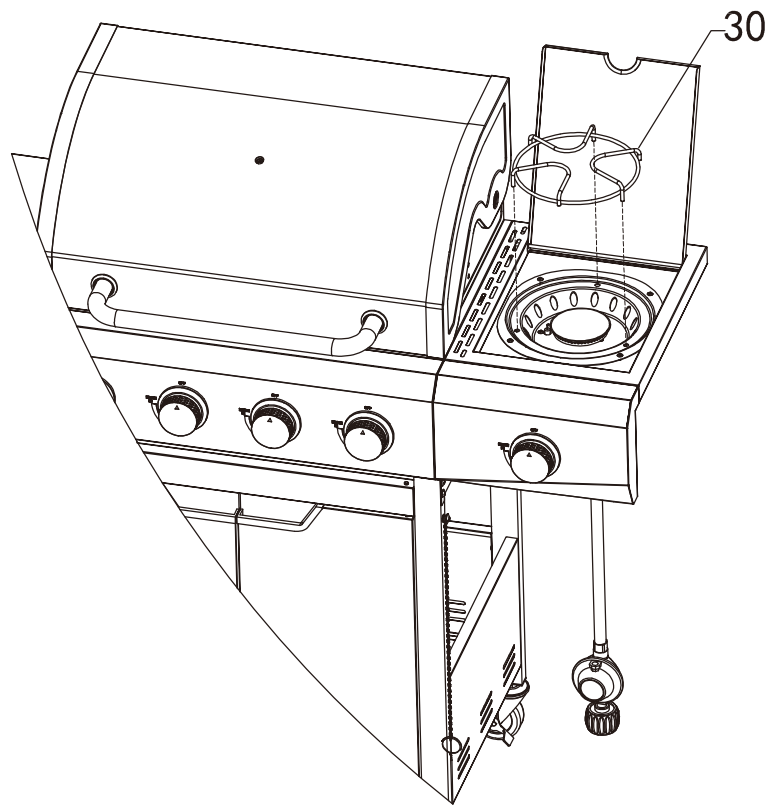

18

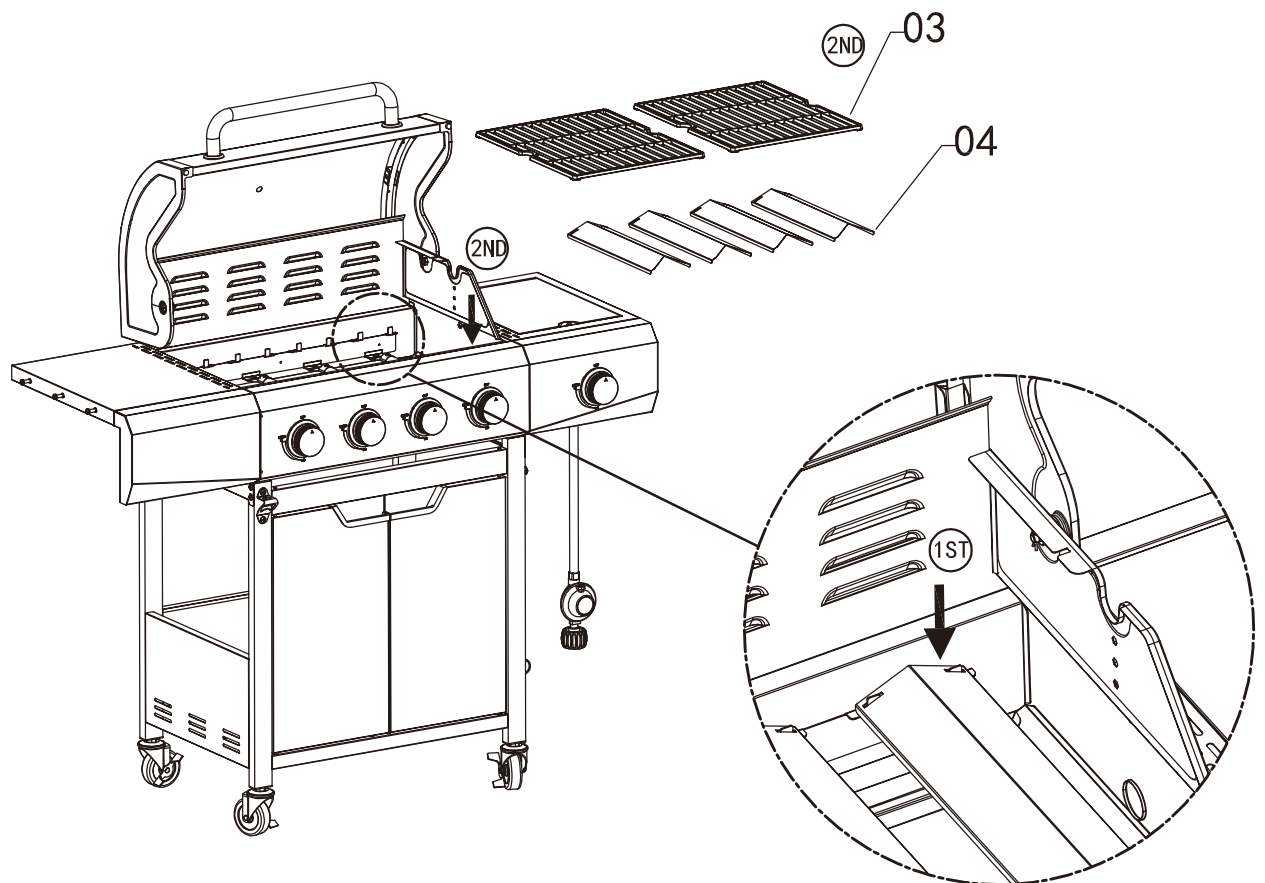

19

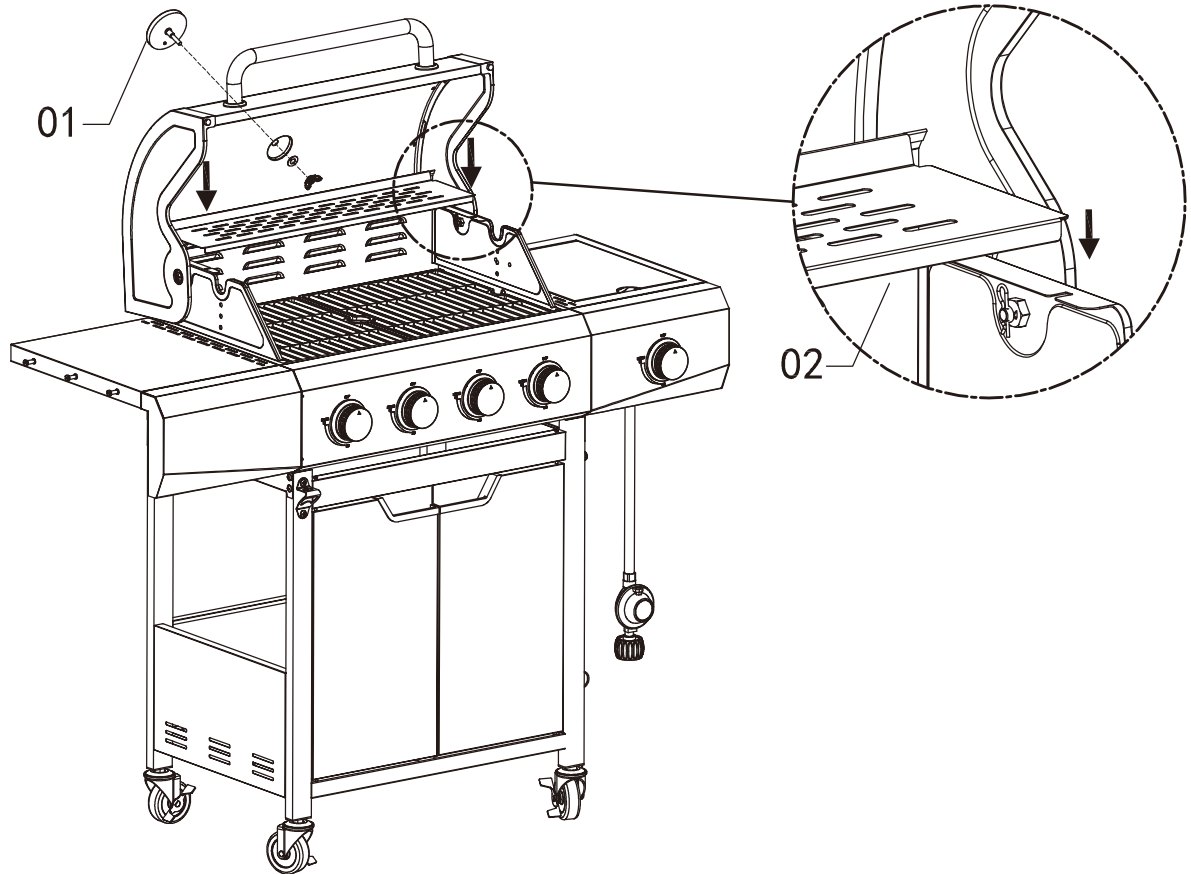

20

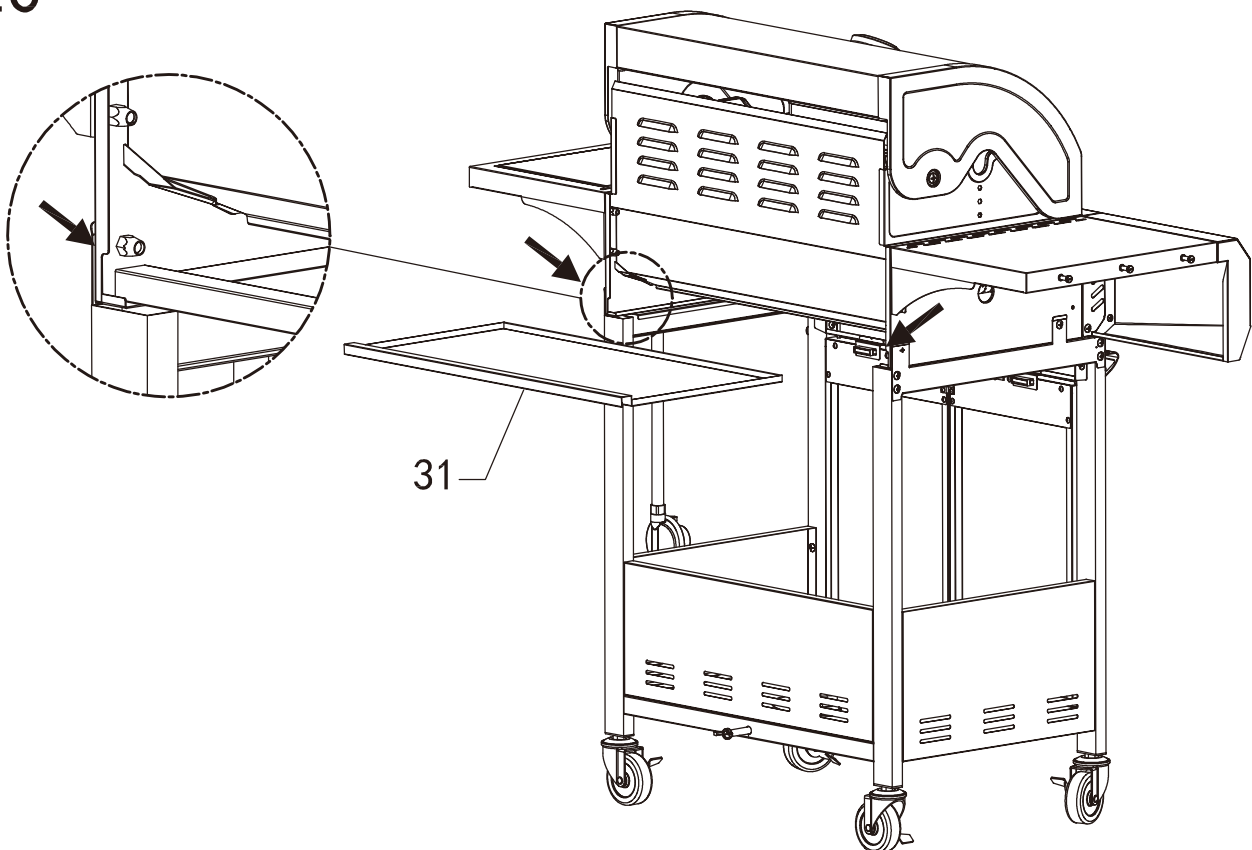

21

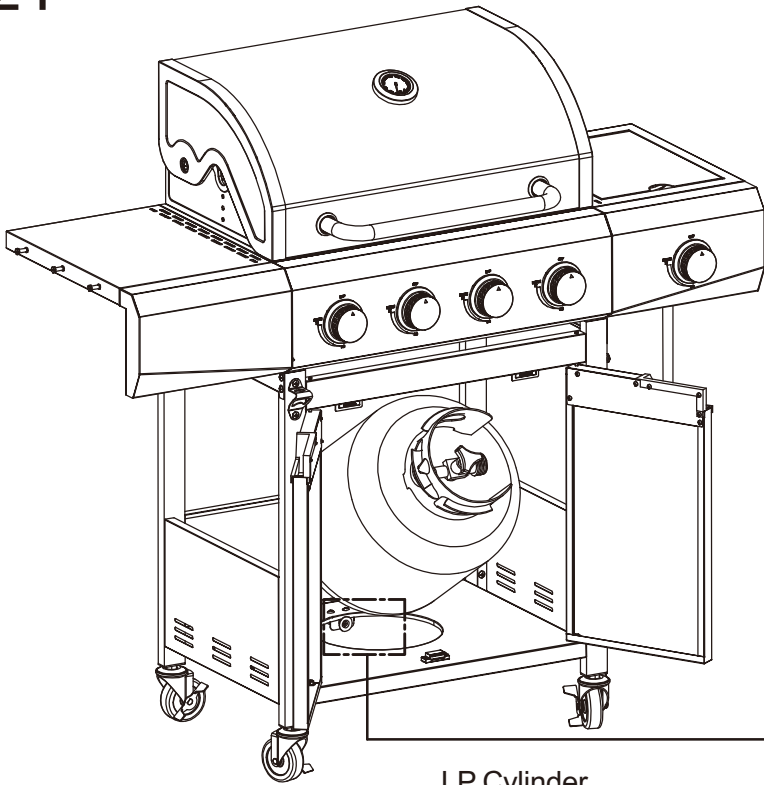

LP Cylinder
(Not Included)

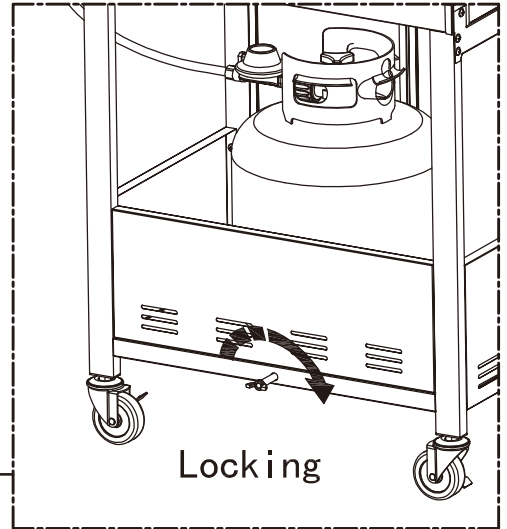

OPERATION INSTRUCTIONS

CHECKING FOR LEAKS

After all connections are made, check all connections and fittings on the LP gas tank valve, gas hose and regulator for leaks with a water and soap solution.

To prevent fire or explosion while testing for a leak:

- Always perform leak test prior to lighting the grill.
- Do not smoke while testing for a leak.
- Always perform leak tests outdoors in a well-ventilated area.
- Do not use any source of flame while testing for leaks.
- Do not use the grill until any and all leaks are corrected.
- If you are unable to correct a leak, disconnect the propane supply and call a gas appliance service dealer.

PERFORM LEAK TEST

- Prepare leak test solution by 50/50 ratio of liquid dish soap and water. Total solution required is approximately 2 - 3 ounces (70 - 90 ml). Put leak test solution in a spray bottle.
- Ensure all control knobs are in the ● OFF position.
- Connect the gas hose to the gas supply.
- Open the LP gas tank valve.
- Spray leak test solution on all gas carrying connections and fittings. Presence of bubbles at areas of applied test solution indicates a gas leak. If leaks are detected or you smell or hear gas, shut off the gas supply valve immediately and repair or replace the defective part. Do not use the grill until all leaks are corrected.

⚠ CAUTION

Only use the regulator and hose assembly provided! If a replacement is necessary, please call our customer service center. Do not use replacement parts that are not intended for this grill.

⚠ WARNING

ALL INSTRUCTIONS AND SAFEGUARDS ON THIS PAGE MUST BE FOLLOWED TO PREVENT FIRE, DAMAGE AND/OR INJURY.

OPERATION INSTRUCTIONS

CONNECTING GAS CYLINDER

The propane gas supply cylinder to be used must be constructed and marked in accordance with the Specifications for LP Gas Cylinders of the U.S. Department of Transportation (D.O.T.) or the National Standard of Canada, CAN/CSA-B339, Cylinders, Spheres and Tubes for Transportation of Dangerous Goods; and Commission, as applicable; and provided with a listed overfilling prevention device.

Use only 20-pound cylinders (height: 18.11 inches, tank diameter: 9.84 inches, foot diameter: 8.03 inches) equipped with a cylinder connection device compatible with the connection for outdoor cooking appliances.

The cylinder must include a collar to protect the cylinder valve. The gas cylinder should not be dropped or handled roughly!

If the appliance is not in use, the gas cylinder must be disconnected. Storage of an appliance indoors is permissible ONLY if the cylinder is disconnected and removed from the appliance. Cylinders must be stored outdoors out of the reach of children and can not be stored in a building, garage or any other enclosed area. Your cylinder must never be stored where temperatures can reach over 125°F.

Place dust cap on cylinder valve outlet whenever the cylinder is not in use. Only install the type of dust cap on the cylinder valve outlet that is provided with the cylinder valve. Other types of caps or plugs may result in leakage of propane.

Before connection, be sure that there is no debris caught in the outlet of the gas cylinder, outlet of the regulator valve or in the outlet of the burner and burner ports. Connect regulator valve and hand-tighten firmly. Keep the propane cylinder valve closed and disconnect the propane cylinder from the regulator valve when the grill is not in use.

DO NOT obstruct the flow of combustion air and ventilation air to the grill. The propane cylinder must be arranged for vapor withdrawal and equipped with a listed overfilling prevention device. Please use the proper cylinder orientation to provide vapor withdrawal. NOTE: The cylinder must be fully upright for the cylinder to have vapor withdrawal only.



Correct



Wrong



Wrong

⚠ CAUTION

- a. Do not store a spare LP-gas cylinder under or near this appliance.
- b. Never fill the cylinder beyond 80 percent full.
- c. If the information in (a) and (b) is not followed exactly, a fire causing death or serious injury may occur.





OPERATION INSTRUCTIONS

NOTE: Other cylinders may be acceptable for use with this appliance if they are compatible with the appliance nesting hole and retention means. Refer to Page 20 of the Assembly Instructions for correct cylinder to cylinder holder connection.

⚠ WARNING

ALL INSTRUCTIONS AND SAFEGUARDS ON THIS PAGE MUST BE FOLLOWED TO PREVENT FIRE, DAMAGE AND/OR INJURY.

CONNECTING THE LP TANK

1. The knob on the LP tank must be closed. Make sure that the knob is turned  clockwise to a full stop. The cylinder supply system must be arranged for vapor withdrawal.
 2. Check that the control knob on the control unit is turned off.
 3. Remove the protective cap from the LP tank valve and coupling nut.
 4. Hold the regulator in one hand and insert the nipple into the valve outlet. Be sure the nipple is centered in the valve outlet. The coupling nut connects to the large outside threads on the valve outlet. Use care—do not cross thread the connection.
 5. Hand-tighten the coupling nut  clockwise until it comes to a full stop. Firmly tighten by hand only. Do not use tools.
- To Disconnect:** Fully close the tank valve by turning  clockwise. Turn the coupling nut  counterclockwise until the regulator assembly detaches.

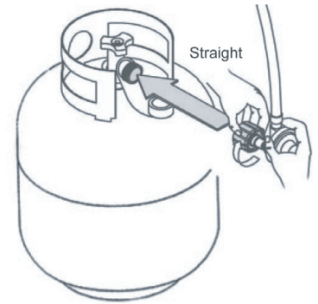

⚠ WARNING

In the connection process, make sure:

- the regulator inlet connector mates with the cylinder valve outlet properly, safely and firmly.
- the LP gas hose does not come in contact or remain in contact with the firebox.

OPERATION INSTRUCTIONS

Lighting The Grill

Before first use:

Remove all hangings or plastic straps, if present. Before you cook on your new gas grill, it is important to clean your grill with heat. To do this, operate the grill for approximately 15 minutes with the lid closed and the control knob in the highest position. This will clean the internal parts by burning off any residue and odor from the manufacturing process.

⚠ CAUTION

If the flame extinguishes accidentally during ignition or operation, immediately **TURN OFF** the cylinder valve and then **TURN OFF** the control knob.

⚠ WARNING

Do not lean over grill when lighting. Read instructions before lighting.

1. Check that the control knobs are in the ● OFF position.
2. Open valve at tank fully by turning ↺ counterclockwise.
3. Open lid during lighting.
4. Push igniter ⚡ down 3 to 4 seconds while turning right side control knob to the high 🔥 position. The burner should ignite. If ignition does not take place within 5 seconds, immediately turn the control knob to the ● OFF position. Wait 5 minutes and repeat step 4 above or refer to match lighting instructions in the manual.
5. Repeat step 4 above to ignite all other burners.

If the burner still does not light, check that there is gas in the cylinder and follow the match lighting instructions. Check the Troubleshooting Guide on page 29 for more information.

OPERATION INSTRUCTIONS

LIGHTING THE GRILL WITH A MATCH

1. Open the lid.
2. Insert a match in the end of the matchholder that is installed on the right door assembly.
3. Light the match.
4. Immediately place the lit match through the spaces in the grill gates near the ports of the burner between the heat tents as shown. Make sure the lit match is close to the burner ports.
5. Press in the control knob that operates the burner and rotate ↺ counter-clockwise to 🔥 High position and burner should light immediately.
6. Repeat 2–5 steps to light the remaining burners.
7. Adjust burners to desired cooking settings.

⚠ CAUTION

Make sure all burners controls are off except for the burner being lit and the burners that have been lit.

Main Burner Match Lighting

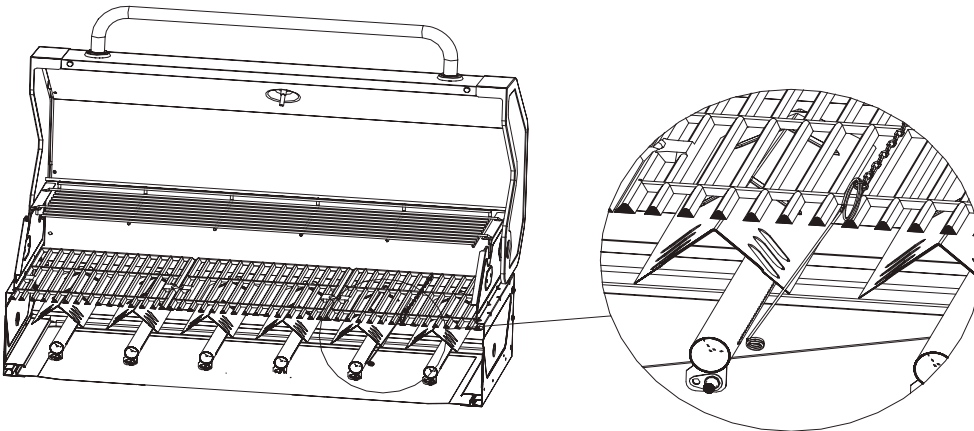

Side Burner Match Lighting

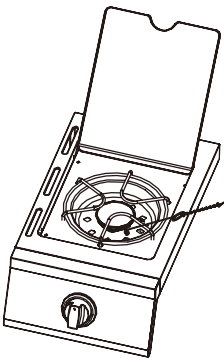

SHUTDOWN INSTRUCTIONS

1. Turn control knobs ↻ clockwise to the ● OFF position.
2. Close valve at tank fully by turning ↻ clockwise.
3. Close lid.

Turn off LP supply at cylinder when appliance is not in use.

CARE AND MAINTENANCE

Cooking Grates

The best time to 'burn-off' the cooking grates is after every use (approx. 15 minutes). The grill is already hot from cooking thus requiring less fuel to obtain necessary temperature for 'burn-off'.

To 'burn off' or heat clean your grill, turn the burners to highest position and run for 15 minutes with the lid closed. Then turn off the burners and use a wire brush to clean excess food residue from the grates.

The porcelain grates have an enamel finish (similar to glass) and should be handled with care not to chip.

⚠ CAUTION

Ensure the grill is cool before cleaning and conducting maintenance and with the gas supply turned off at the LP-Gas Cylinder.

Recommended Cleaning Supplies

Mild liquid dish soap, warm water, nylon cleaning pad, wire brush

DO NOT use cleaners that contain acid, mineral spirits or any abrasive substance.

Outside Surfaces

It is recommended to use only mild dish soap and hot water to clean grill and grill parts.

Rinse with warm water.

Inside Bottom Pan of Grill Body

To avoid flare-ups, the bottom pan of the cooking box should be kept clean on a regular basis.

Remove residue using a brush, scraper and/or cleaning pad. Wash with mild dish soap and warm water. Rinse with warm water. Avoid water splashing into venturi tubes of burners.

Heat Tents

Clean residue with wire brush and wash with mild dish soap and warm water. Rinse with warm water.

Grease Cup

Empty the grease cup and clean with mild dish soap and warm water on a regular basis.

Checking The Flame

For maximum fuel efficiency and cooking performance, flame should be a blue-yellow color and be between 1- 2 inches high.

To check the flame, view the flame through the holes in both sides of the firebox.

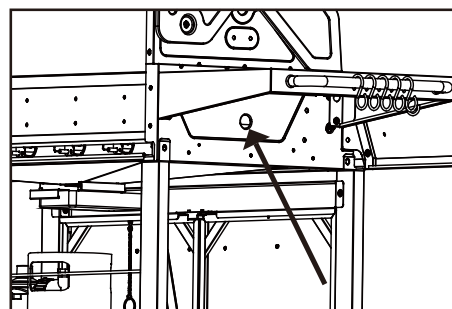

Hole for viewing the flame

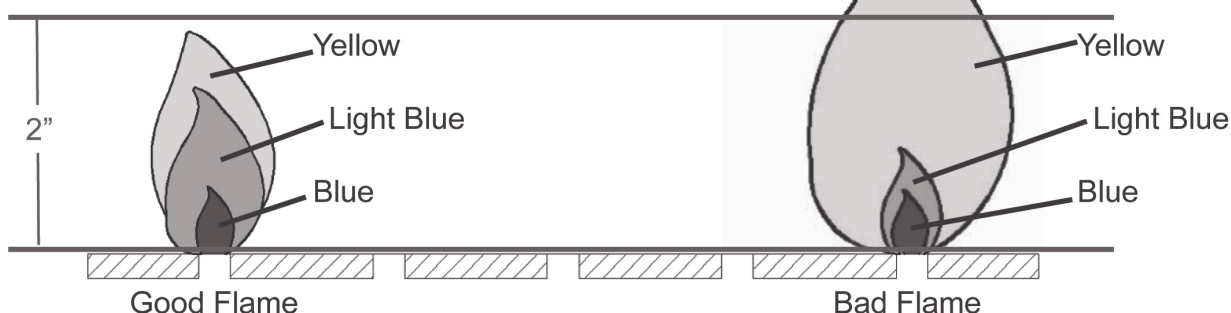

CARE AND MAINTENANCE

Burner Assembly

Removing The Burner Assembly

1. Make sure all control knobs are in the ● OFF position, gas supply valve is closed, and the gas hose is disconnected from the gas supply.
2. Remove the ignitor cap, then remove the AA battery (1.5V) (K) out of the ignitor body. Replace ignitor cap.
3. Open lid and remove warming rack, cooking grates, heat tents, clip for burner, ignition chain and main burner.
4. Remove hinge pin as illustrated in Figure 1.
5. Slide main burners out of firebox.
6. Detach ignition wire from electrode in Figure 2.

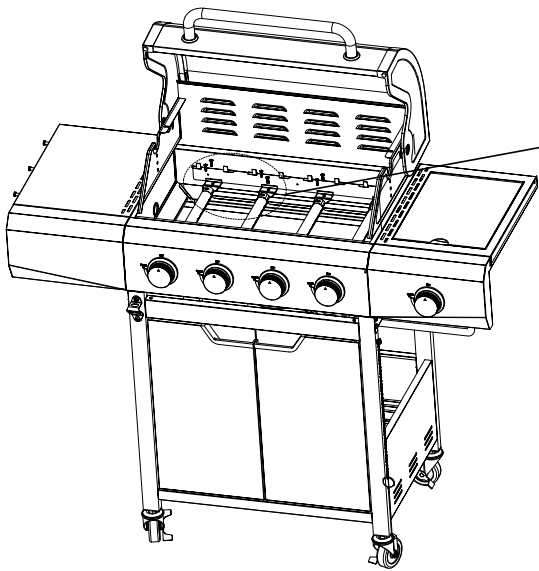
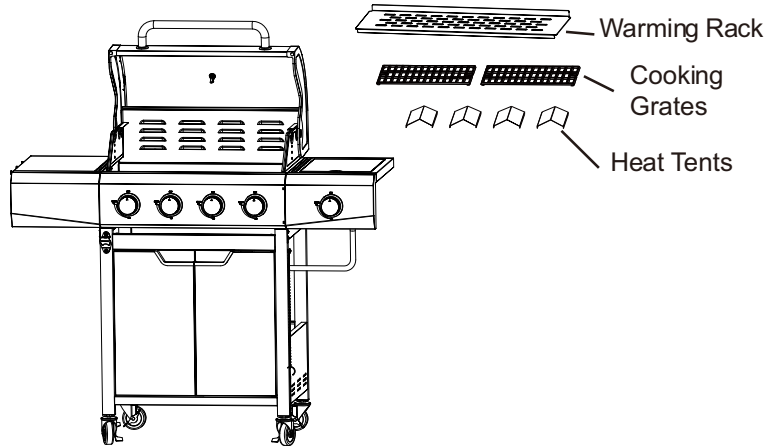

Figure 1

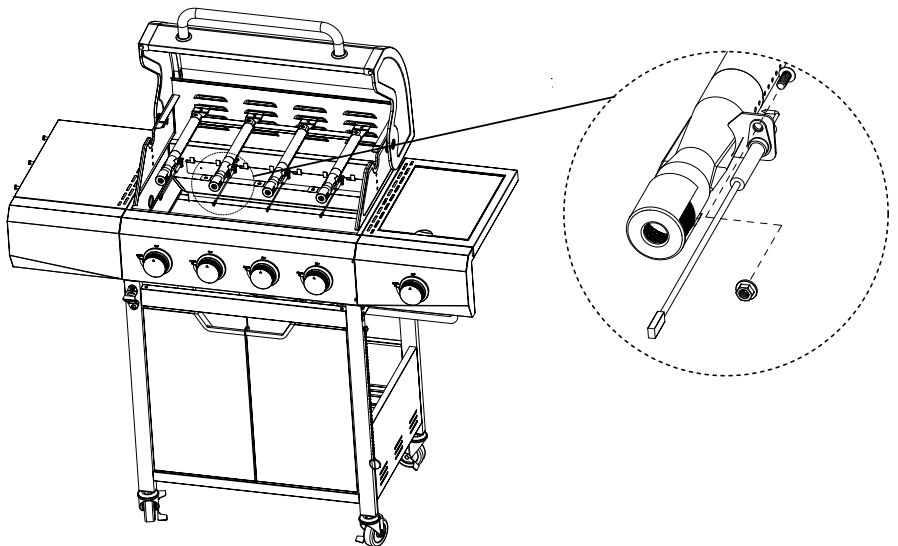

Figure 2

CARE AND MAINTENANCE

Cleaning the Burner Assembly

– Make sure the grill is cool

1. Turn gas off at the control knobs and LP gas cylinder.
2. Disconnect LP gas cylinder from regulator and hose.
3. Remove warming rack, cooking grates and heat tents.
4. Detach burner by removing the cotter pins at the back of the burners to detach them from the brackets.
5. Detach ignition wire from electrode by hand only. DO NOT use pliers or any other tool as it may damage the electrode or wire.
6. Lift burner slowly.
7. Ensure all burner ports are clear of clogs. Use of a pin or paper clip works well.
8. Ensure burner is free of any damage. If damage is found, replace it with new burner.
9. Ensure the end of the burner and primary air screen are clear from insect nests, dirt or debris.

Re-installing the Burner

Ensure that gas valve orifices are correctly positioned inside burner inlet (venturi).

The use of a flashlight may be necessary to ensure the correct position.

It is recommended to view the correct position through the firebox vent holes as illustrated below.

Reattach each burner with the hinge pin and reattach the ignition wire to electrode.

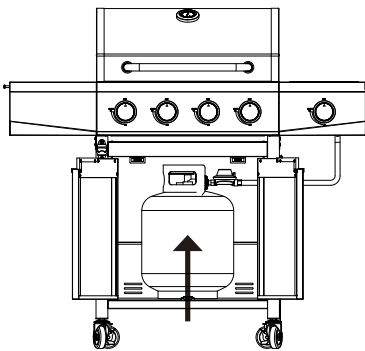

View the correct position
from the bottom of the firebox

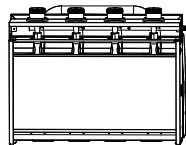

Bottom View

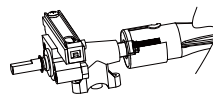

Correct

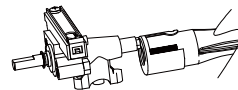

Wrong

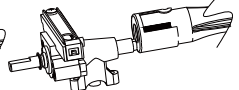

Wrong

! WARNING

If the instructions above are not followed, a fire or explosion may result, possibly causing serious bodily injury or death.

Other Care and Maintenance

It is recommended that inspection and service on this appliance be conducted annually by a qualified service person.

It is recommended that you always check that the outdoor cooking appliance area is clear and free from combustible material, gasoline and other flammable vapors and liquids before lighting.

It is recommended that you regularly check that the flow of combustion and ventilation air are not obstructed.

It is recommended that you regularly check that the ventilation openings of the grill cabinet are free and clear from debris.

It is recommended that you regularly check and clean the burner/venturi tubes for insects and insect nests. A clogged tube can lead to a fire beneath the grill.

CARE AND MAINTENANCE

The electronic ignition requires 1 “AA” alkaline battery, which is included.

!WARNING

DO NOT mix old and new batteries.
 DO NOT mix alkaline, standard (Carbon-Zinc), or rechargeable (Nickel-Cadmium) batteries.
 DO NOT dispose of batteries in fire. Improper disposal may cause batteries to leak or explode.

TROUBLESHOOTING

If you have any questions regarding the product, please email us Via wangjue122@qq.com, or dark210308@126.com

PROBLEM	POSSIBLE CAUSE	CORRECTIVE ACTION
The burner does not light by using the ignitor procedure (weak or no spark being generated).	<ol style="list-style-type: none"> 1. The igniter electrode may be covered with grease or residue. 2. The igniter electrode may have a loose or disconnected wire. 3. Cracked or broken ignition electrode . 4. Dead battery or faulty battery connection. 	<ol style="list-style-type: none"> 1. Clean the ignitor electrode. 2. Check the connection and reconnect any loose or disconnected wires. 3. Replace ignition electrode (see Replacement parts list). 4. Perform any of the following: <ol style="list-style-type: none"> a. Replace battery b. Check to see if battery is inserted correctly. c. Check for any corrosion around battery terminals. d. Check wire connections as stated above.
Low heat.	<ol style="list-style-type: none"> 1. Insufficient gas pressure to the unit. 	<ol style="list-style-type: none"> 1. Call a qualified service agency to check the gas supply pressure and correct the pressure.
Excessive Flare Ups	<ol style="list-style-type: none"> 1. Grease and/or residue build-up on heat tents or in firebox. 2. Excessive dripping of fat or marinade from food. 3. Cooking temperature too high. 	<ol style="list-style-type: none"> 1. Clean the grill components. 2. Trim the fat from meat and use non-oil based marinades. 3. Lower temperature accordingly.

TROUBLESHOOTING

PROBLEM	POSSIBLE CAUSE	CORRECTIVE ACTION
The burner will not light with a match.	<ol style="list-style-type: none"> 1. Match not reaching burners (when holding match with hand). 2. Empty tank. 3. Poor connection between valve regulator and LP cylinder coupling. 4. Burner inlet blocked. 	<ol style="list-style-type: none"> 1. Use match holder found in right door. 2. Check fuel level and refill tank if necessary. 3. Turn off grill knobs, close the cylinder valve at top of cylinder and check the connection between the regulator valve and cylinder coupling. Disconnect and reconnect, if necessary. 4. Clean the burner inlet (venturi) and burner as described by the Care and Maintenance section in the manual.
No gas flow or an obstructed gas flow.	<ol style="list-style-type: none"> 1. Tank valve not on or fully opened. 2. Empty tank. 3. Poor connection between valve regulator and LP cylinder coupling. 4. Burner inlet blocked. 	<ol style="list-style-type: none"> 1. Fully open tank valve by turning counterclockwise. 2. Check fuel level and replace fuel if necessary. 3. Turn off grill knobs, close the LP cylinder valve at top of cylinder and check the regulator valve and cylinder coupling. Disconnect and reconnect, if necessary. 4. Clean the burner inlet (venturi) and burners as described by the Care and Maintenance section in the manual.

NOTICE: Some states do not allow the exclusion or limitation of incidental or consequential damages or limitations on how long an implied warranty lasts, so the above limitations or exclusions may not apply to you. This warranty gives you specific legal rights and you may also have other legal rights which may vary from state to state.

Item Name: 4-Burner LP Gas Grill With Side Burner
 Model #: GA5006
 Main Burner Total rated BTU: 4,200 BTU/Hr
 Side Burner rated BTU: 9,000 BTU/Hr

Warning:

Use outdoor only.
 Read the instructions before using the appliance.
 WARNING: Accessible parts may be very hot.
 Keep young children away.

Lighting Instruction:

1. Open the lid of the grill before attempting to light the burners.
2. Turn all the control knobs to the "●" OFF position.
3. Connect the regulator to the gas bottle. Turn on the gas supply at the regulator and at the gas bottle valve.
4. Push down the control knob and keep pressing while turning counter to the "MAX" position. A clicking sound will be heard and ignition will take place.
5. If the burner has not lit, turn knob off, wait 5 minutes and repeat step 4.
6. Repeats step 4 to 5 for other burners.