



# INSTRUCTION MANUAL

---

5-Piece Dining Table Set  
with Glass Top

---

As shoppers, we're always trying to find the perfect balance between quality & value. At BCP, we believe we've achieved that. Our diverse catalog of everyday essentials is tailored especially to our customers & guaranteed to hit that sweet spot of high quality & low price.

— Always. —

## NOTICE

Please retain these instructions for future reference.

- Please do not exceed the weight limitations of this item.
- Do not stand on or use any part of this item as a step ladder.
- Firmly secure all bolts, screws and knobs before use.
- Reconfirm that all bolts, screws, and knobs are secure every 90 days.
- Fasten screws loosely during initial assembly. Do not firmly tighten the screws until the item is completely assembled.
- Do not use or store this item in the proximity of open flame or flammable/combustible chemicals.
- Be aware that some parts are heavy and have sharp edges.
- Do not use this item in a way inconsistent with the manufacturer's instructions as this could void the product warranty.

## TOOLS REQUIRED



ALLEN WRENCH  
(PROVIDED)



250 LBS  
CHAIR  
CAPACITY



80 LBS  
TABLE  
CAPACITY



1 PERSON  
ASSEMBLY



UP TO 45 MIN.  
ASSEMBLY

## HARDWARE

1

M6 X 40MM  
SCREW



12 PCS

2

SUCTION CUP



6 PCS

3

M6 X 15MM  
SCREW



16 PCS

4

M6 X 45mm  
SCREW



24 PCS

## PARTS

A

SHORT TABLE FRAME

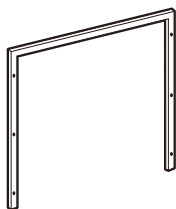

2 PCS

B

LONG TABLE FRAME

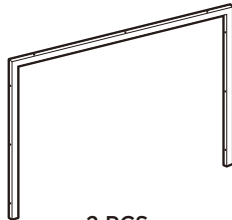

2 PCS

C

GLASS TABLETOP

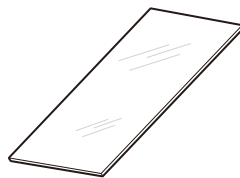

1 PC

## PARTS

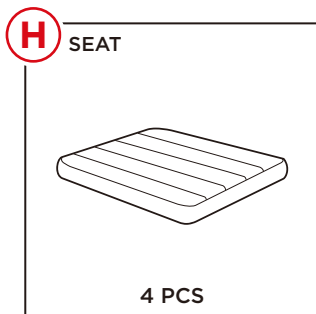
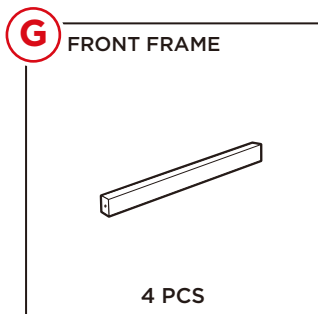
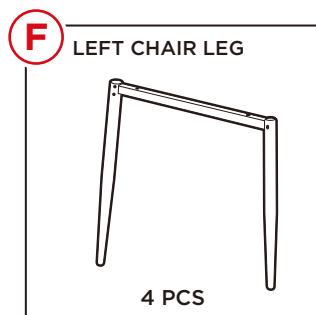
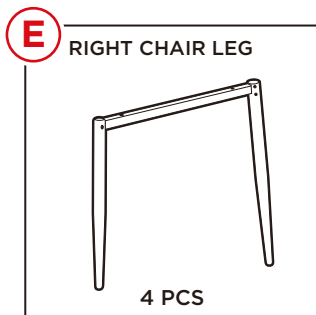
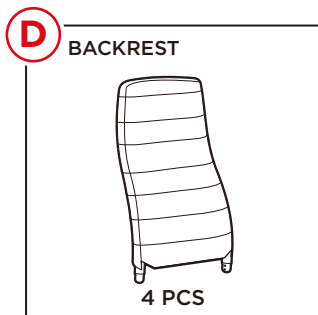

## PRODUCT ASSEMBLY - TABLE

1

Attach the two part A short table frames to the two part B long table frames with twelve part 1 screws.

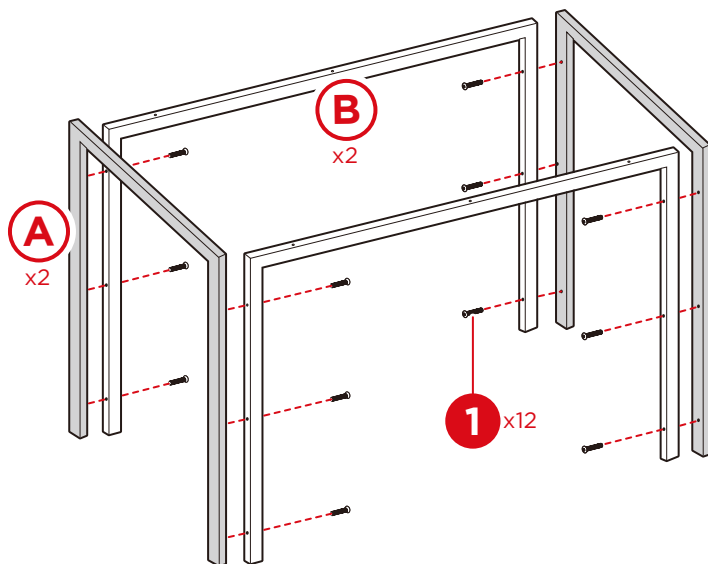

## PRODUCT ASSEMBLY - TABLE

**2**

Insert six part 2 suction cups.

Place the part C glass tabletop onto the frame.

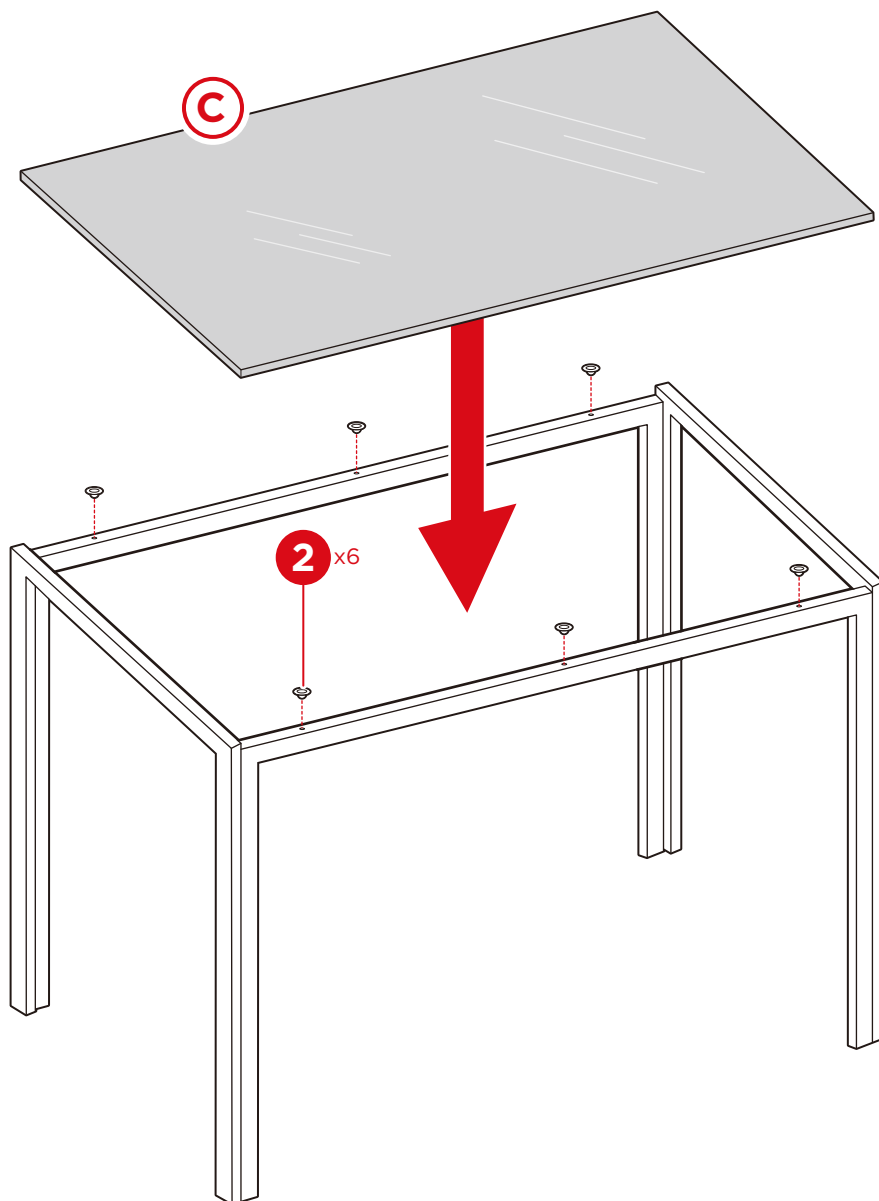

## PRODUCT ASSEMBLY - CHAIR

1

Attach a part D backrest to the part E and F chair legs with four part 3 screws.

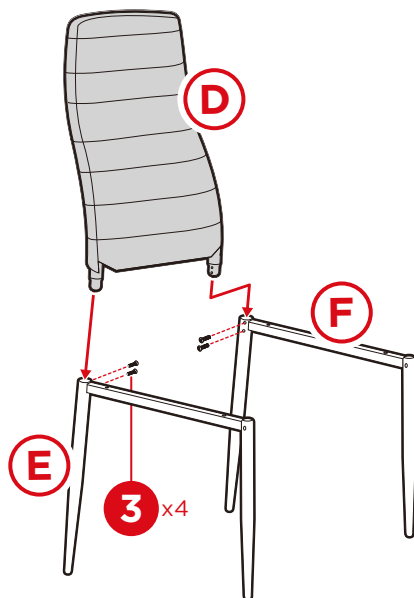

2

Attach a part G front frame with two part 4 screws.

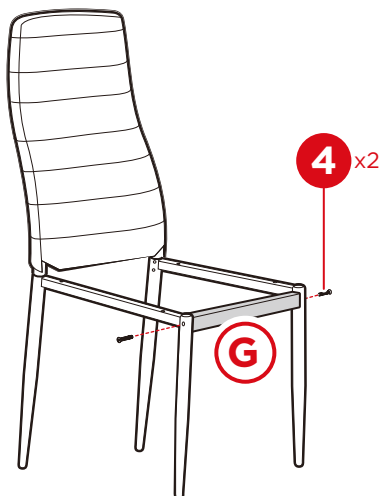

## PRODUCT ASSEMBLY - CHAIR

3

Flip the chair over. Attach a part H seat with four part 4 screws  
Repeat steps 1-3 to build additional chairs.

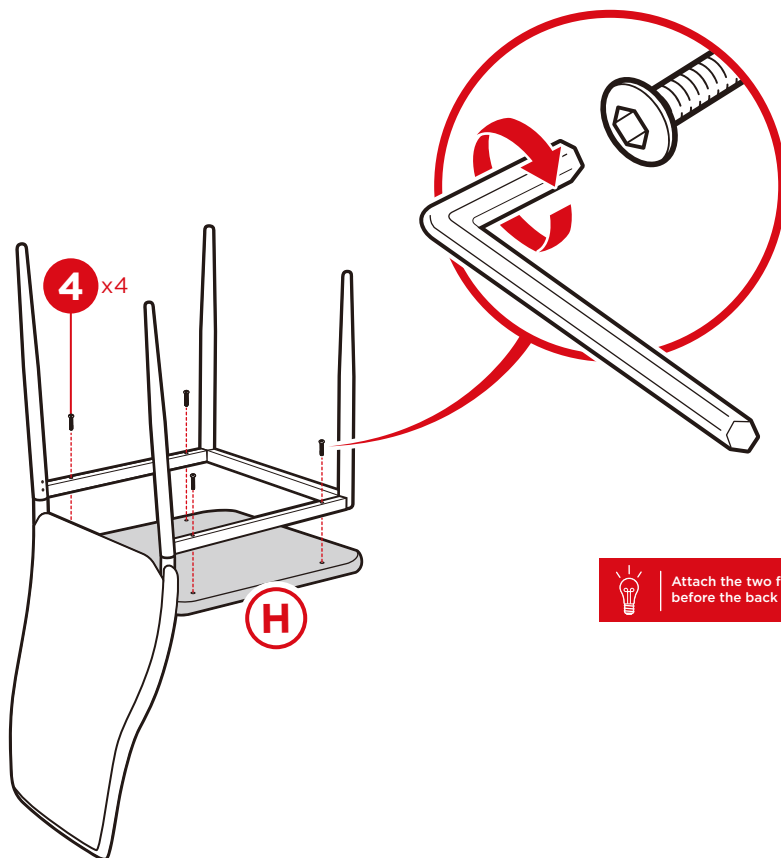



Product Assembly

## PRODUCT WARRANTY INFORMATION

All items can be returned for any reason within 60 days of the receipt and will receive a full refund as long as the item is returned in its original product packaging and all accessories from its original shipment are included. All returned items will receive a full refund back to the original payment method. All returned items will not be charged a re-stocking fee.

All returned items require an RA (Return Authorization) number, which can only be provided by a Customer Service Representative when the return request is submitted. Items received without an RA may not be accepted or may increase your return processing time. Once an item has been received by refunds or replacements will be processed within 5 business days.

All returns must be shipped back to the Products Return Center at the customer's expense. If the reason for return is a result of an error by Products will provide a pre-paid shipping label via email. Boxes for return shipping will not be provided by Products, and is the customer's responsibility to either use the original shipping boxes or purchase new boxes.

Pictures may be required for some returns to ensure an item is not damaged prior to its return. Items returned are not considered undamaged until they are received by Products and verified as such. All damages to items are the customer's responsibility until the item has been received by and acknowledge by Products as undamaged.

## WARNING

Manufacturer and seller expressly disclaim any and all liability for personal injury, property damage or loss, whether direct, indirect, or incidental, resulting from the incorrect attachment, improper use, inadequate maintenance, unapproved modification, or neglect of this product.