

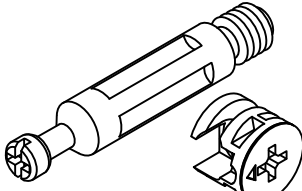
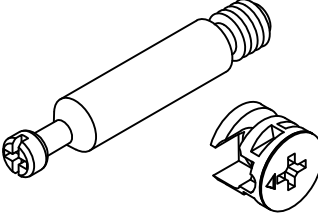
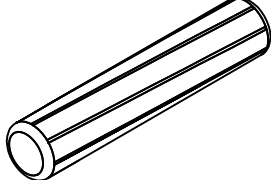
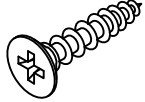
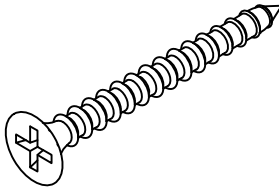
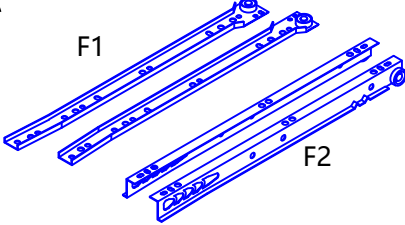
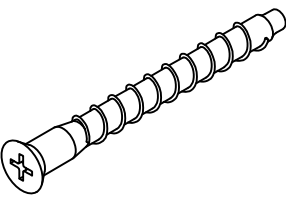
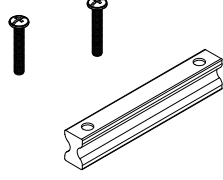
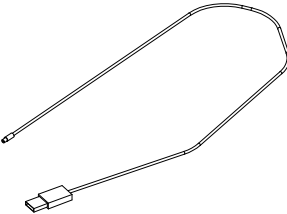
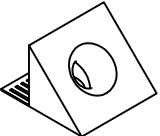
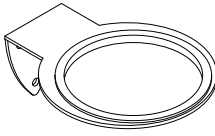
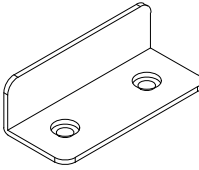
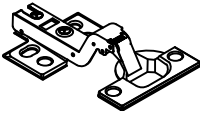
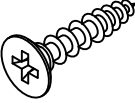
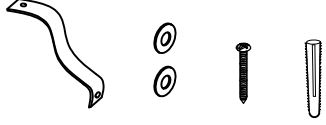
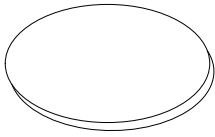
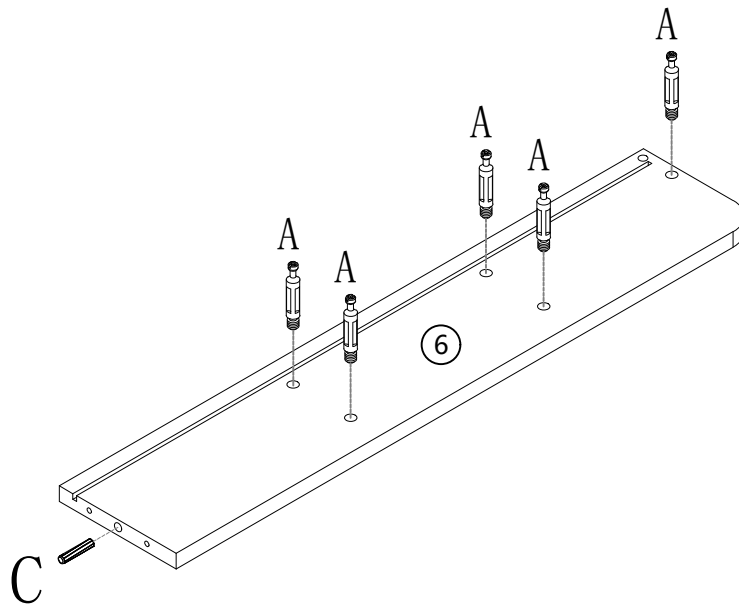

Parts List (EN) / Teile Liste (DE)

<p>A</p>  <p>78 pcs</p>	<p>B</p>  <p>21 pcs</p>	<p>C</p>  <p>$\Phi 8 \times 40 \text{MM}$ 54 pcs</p>
<p>D</p>  <p>$\Phi 3.5 \times 14 \text{MM}$ 69 pcs</p>	<p>E</p>  <p>$\Phi 3.5 \times 35 \text{MM}$ 21 pcs</p>	<p>F</p>  <p>300MM 3 sets</p>
<p>G</p>  <p>$\Phi 7 \times 50 \text{MM}$ 20 pcs</p>	<p>H</p>  <p>7 pcs</p>	<p>J</p>  <p>1 pc</p>
<p>L</p>  <p>20 pcs</p>	<p>M</p>  <p>1 pc</p>	<p>N</p>  <p>2 pc</p>
<p>O</p>  <p>4 pcs</p>	<p>P</p>  <p>$\Phi 3.5 \times 12 \text{MM}$ 8 pcs</p>	<p>R</p>  <p>1 pcs</p>
<p>W</p>  <p>99 pcs</p>		

Assembly (EN) /Montageschritte (DE)

STEP 1



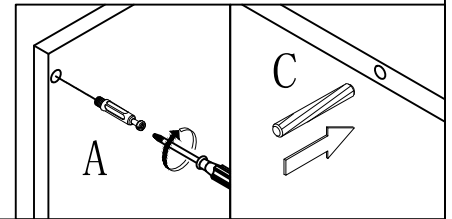

	Ax5pcs
	Cx1pcs

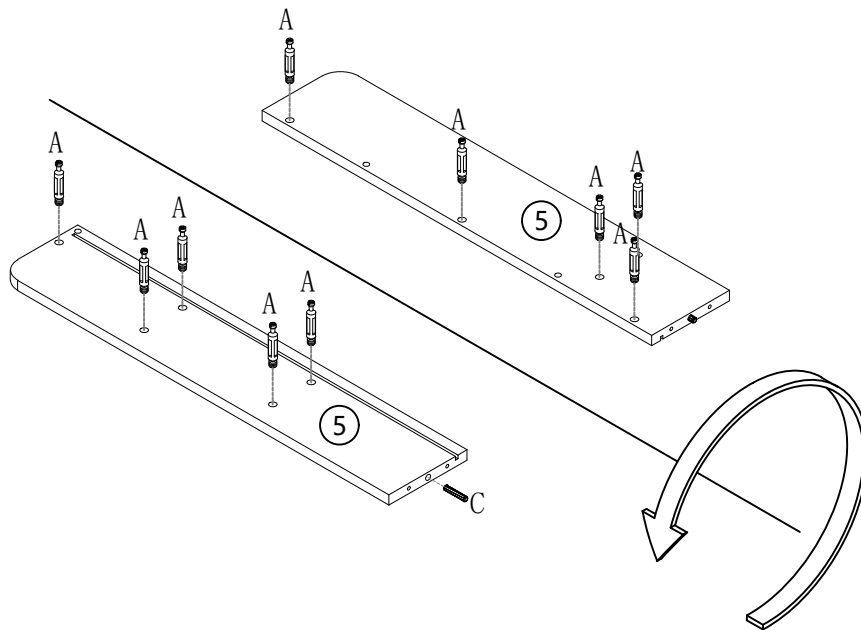

STEP 2



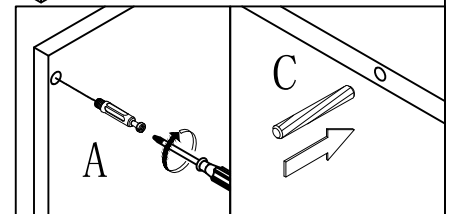

	Ax10pcs
	Cx1pc

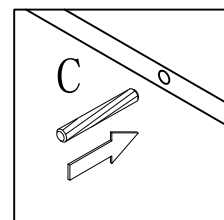
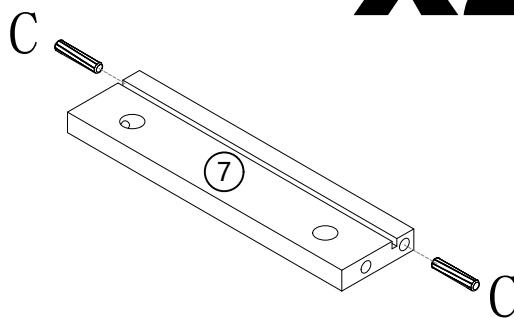

STEP 3

x2



 Cx4pcs

STEP 4

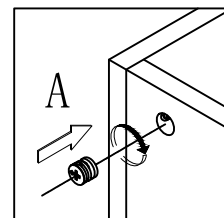
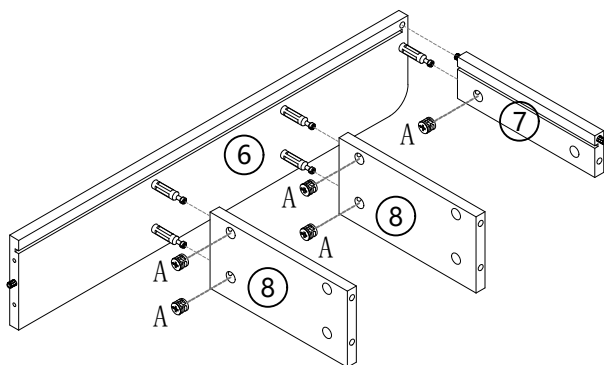

 Ax5pcs

STEP 5

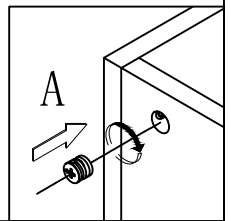
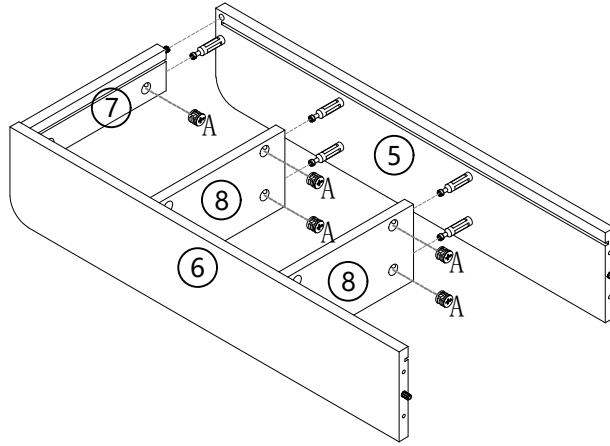

Ax5pcs

STEP 6

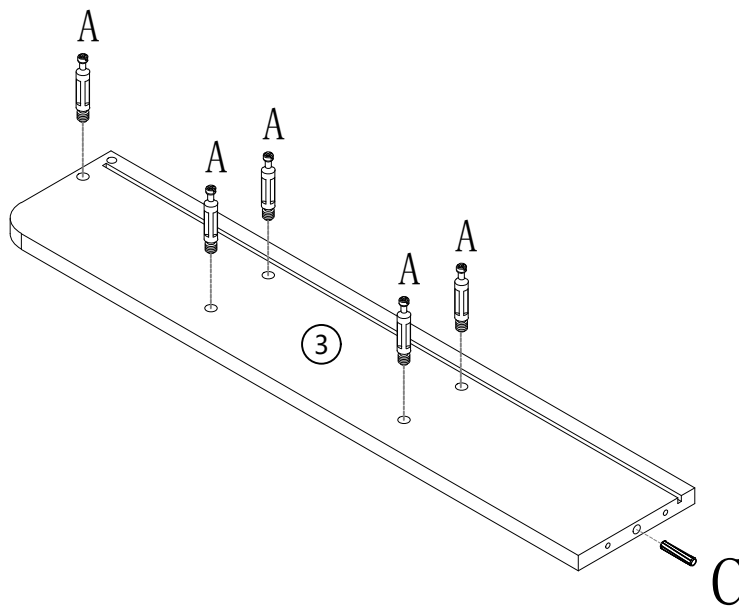

C



Ax5pcs



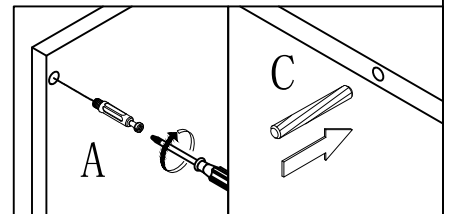

Cx1pcs

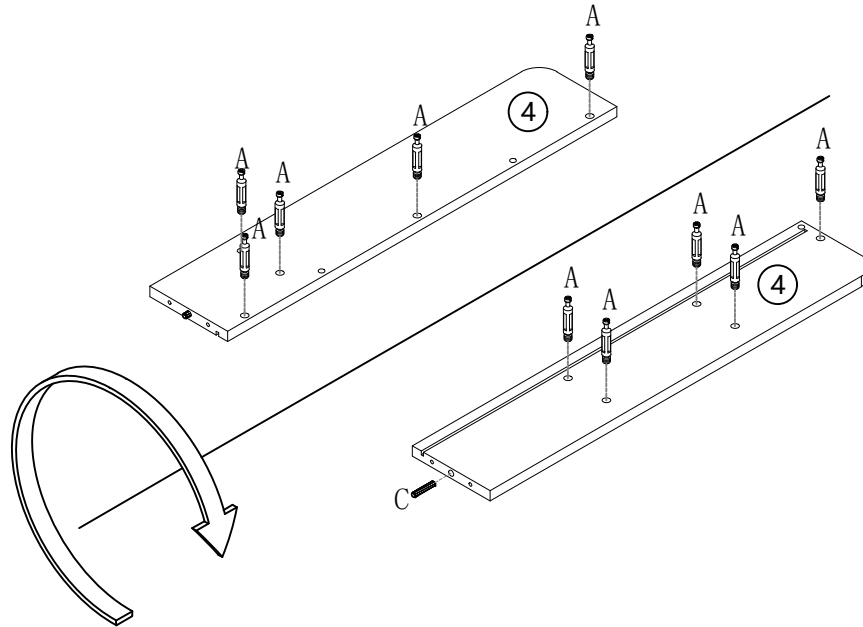

Assembly (EN) /Montageschritte (DE)

STEP 7



	Ax10pcs
	Cx1pc

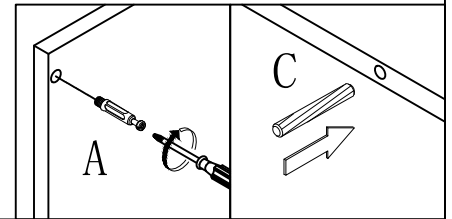

STEP 8

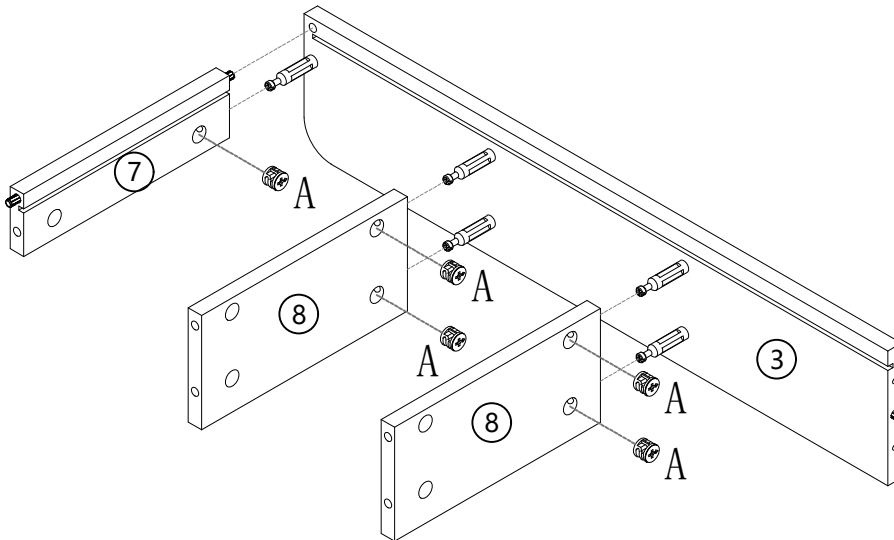

	Ax5pcs
--	--------

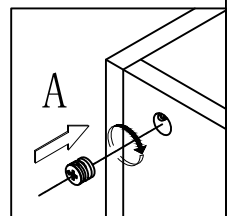

Assembly (EN) /Montageschritte (DE)

STEP 9

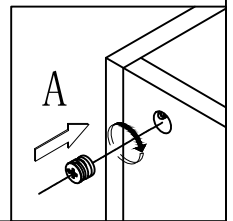
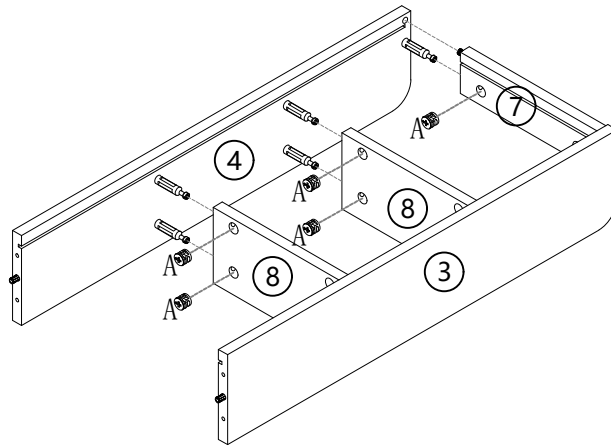

Ax5pcs

STEP 10

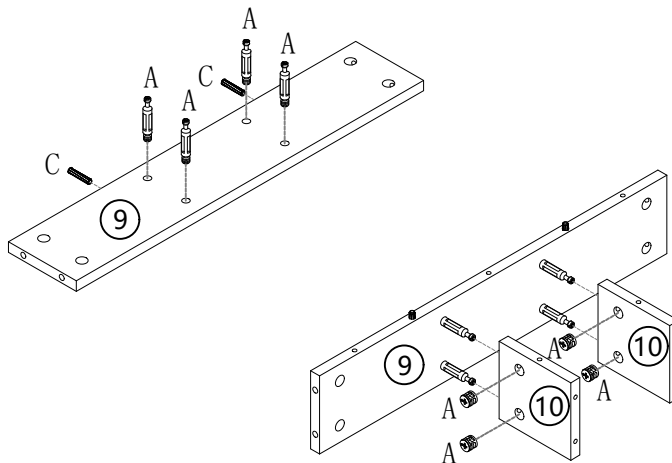

Ax4pcs



Ax4pcs



Cx2pcs

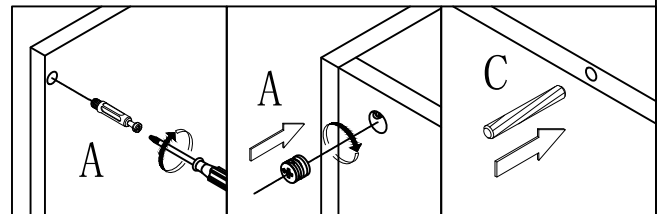

STEP 11

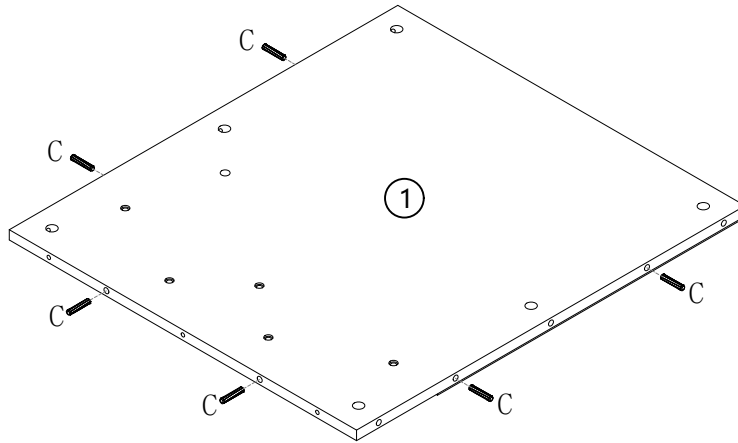

Cx6pcs

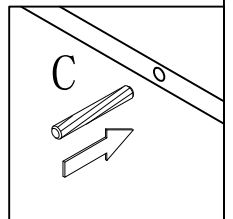

STEP 12

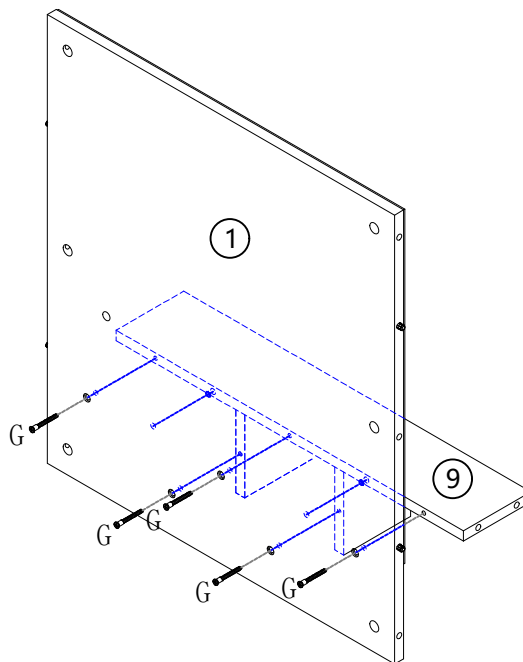

Gx5pcs

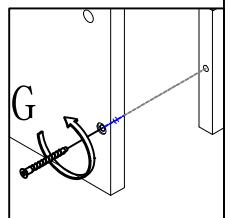

STEP 13

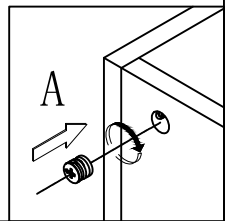
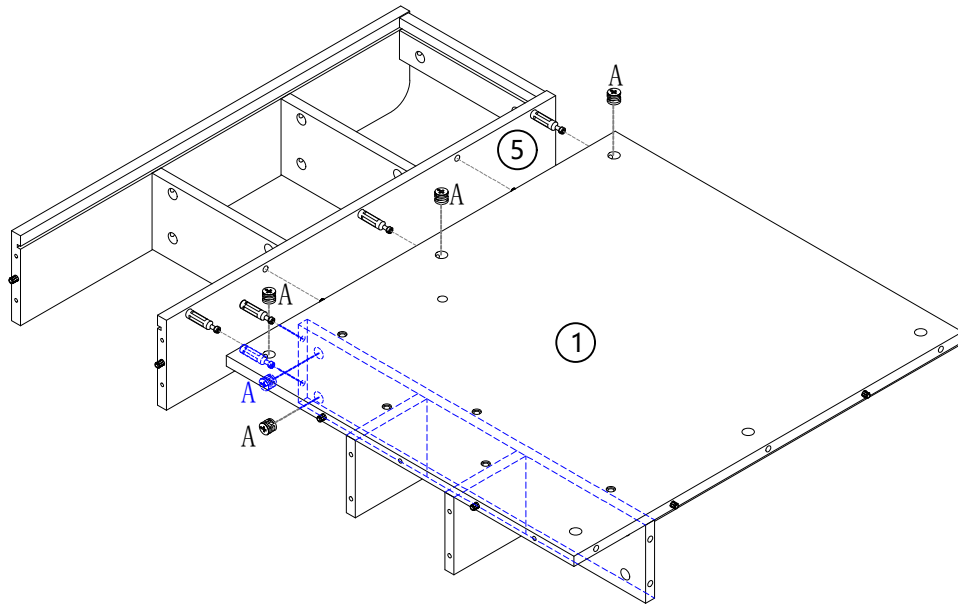

Ax5pcs

STEP 14

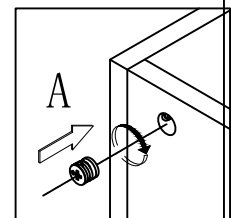
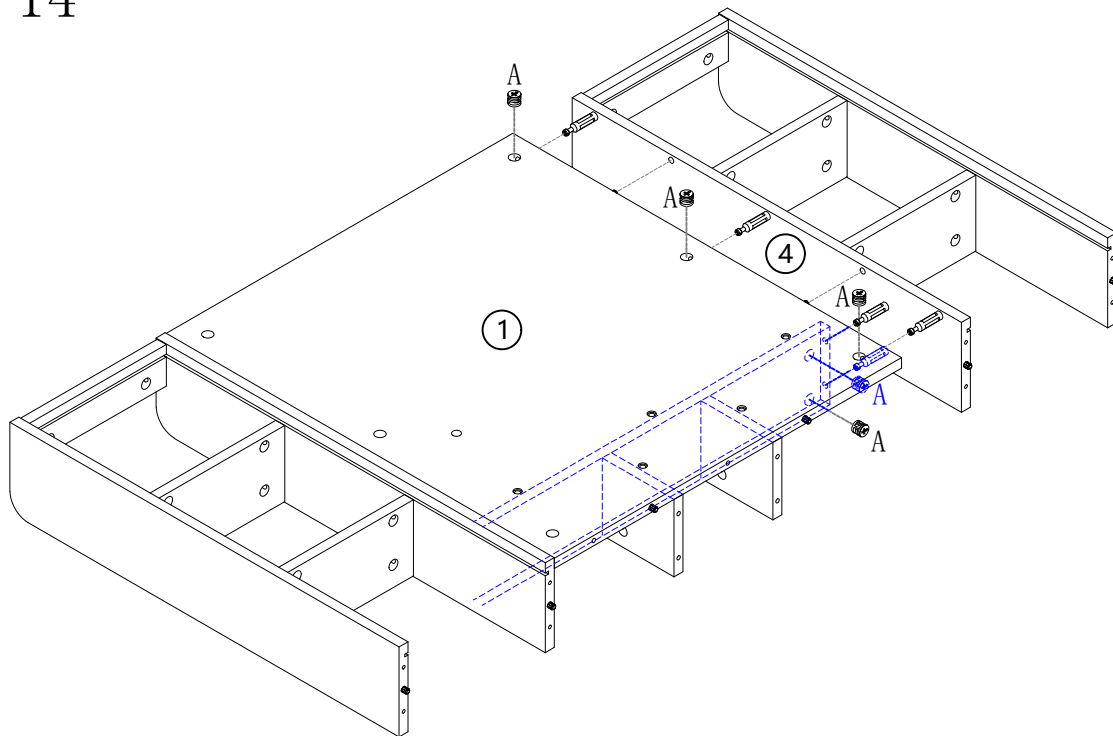

Ax5pcs

Assembly (EN) /Montageschritte (DE)

STEP 15

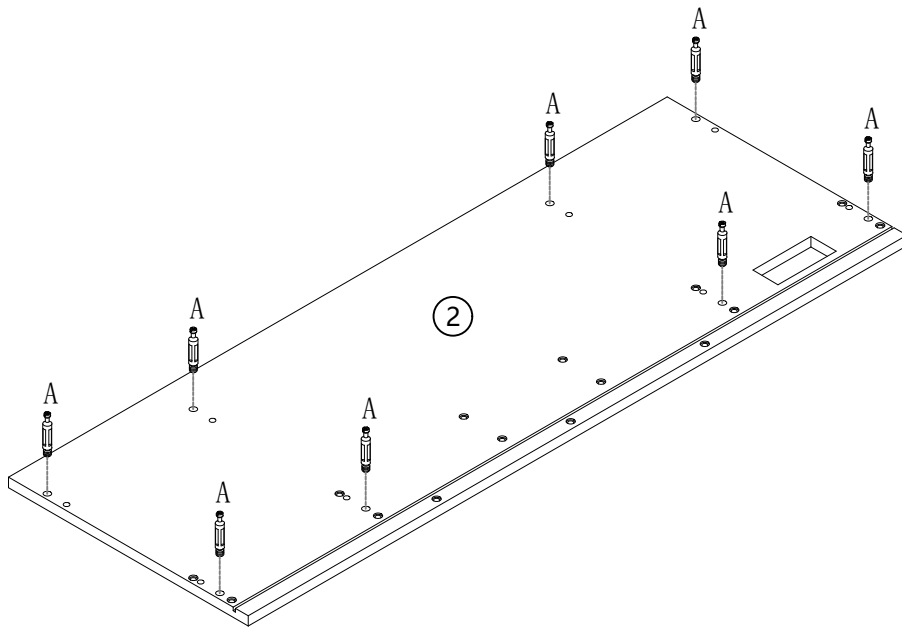

Ax8pcs

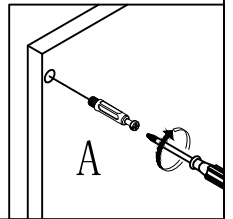

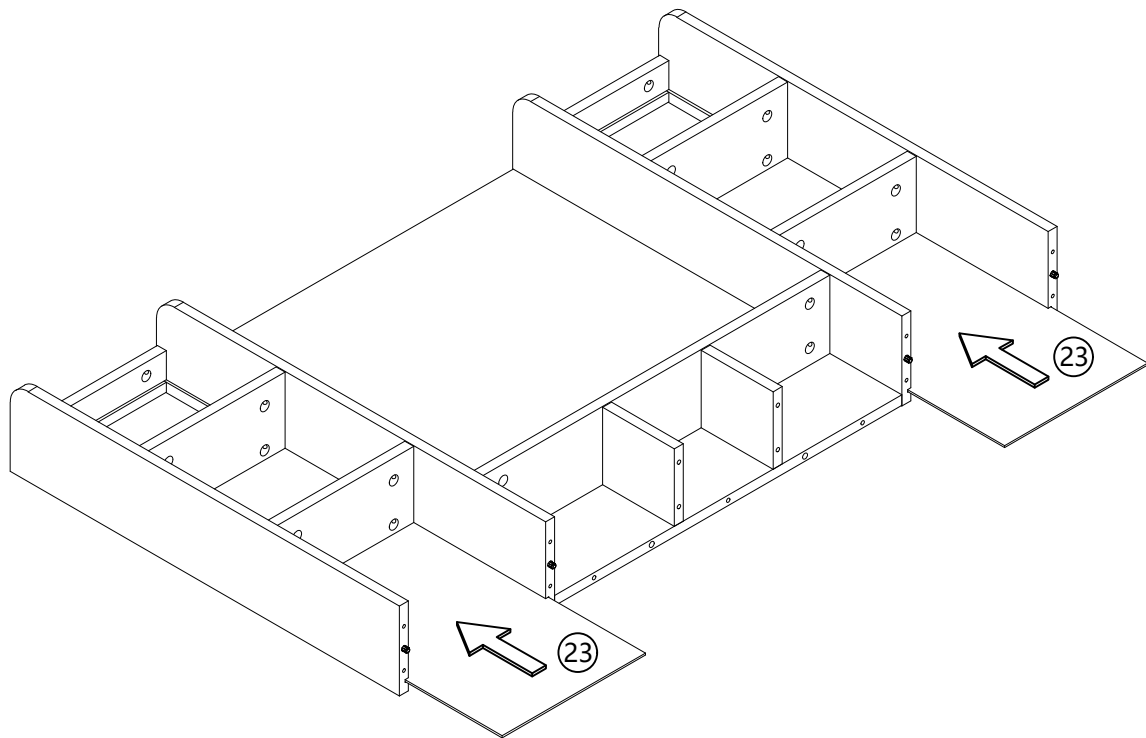

STEP 16



Assembly (EN) /Montageschritte (DE)

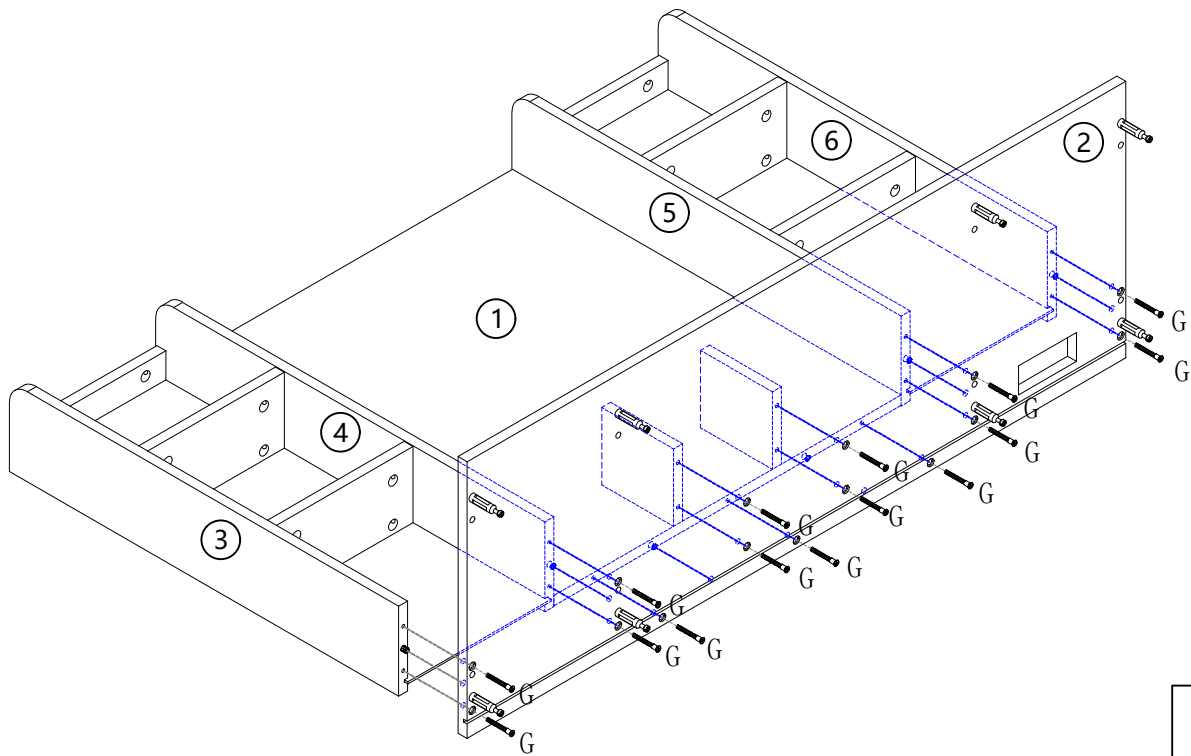



STEP 17

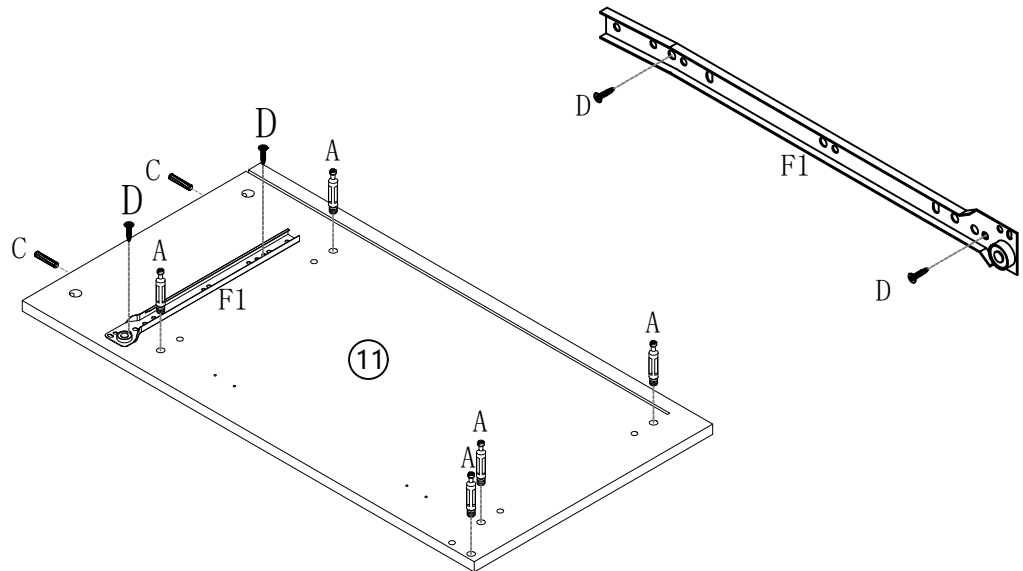

	Gx15pcs
--	---------

STEP 18





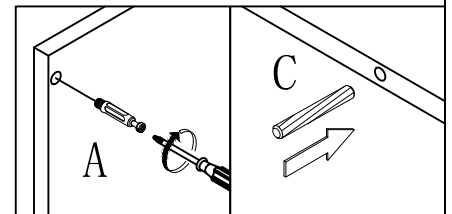

	Ax5pcs
	Cx2pcs
	Dx2pcs
	F1x1pcs

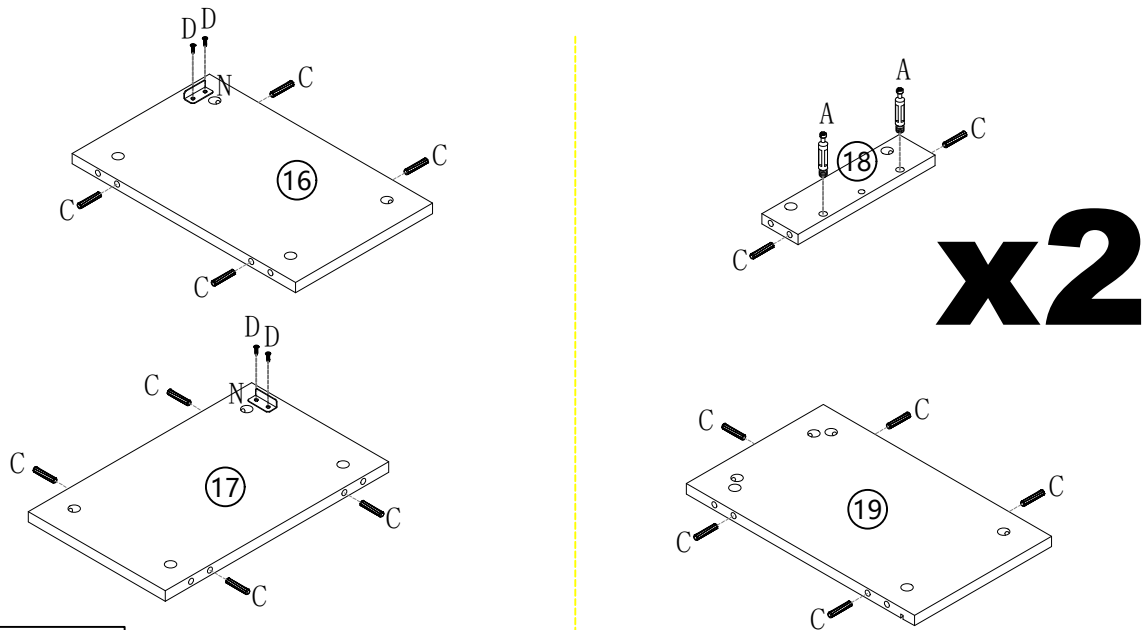

Assembly (EN) /Montageschritte (DE)

STEP 19



	Ax4pcs
	Cx22pcs
	Dx4pcs
	Nx2pcs

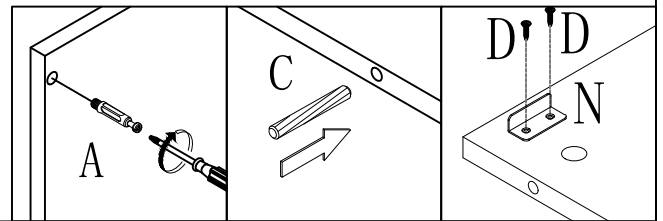

STEP 20

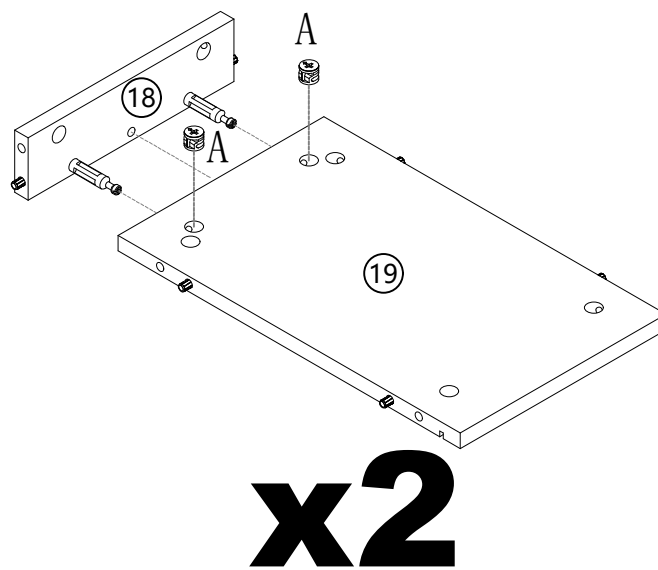

	Ax4pcs
--	--------

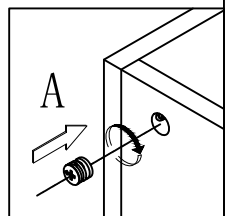

STEP 21

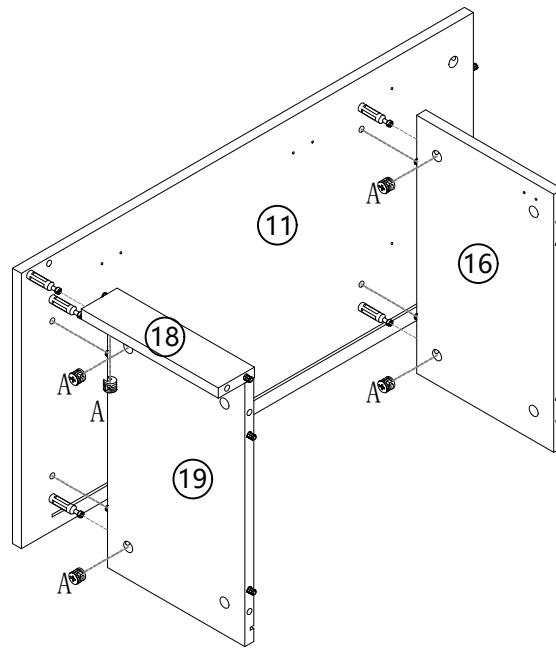

Ax5pcs

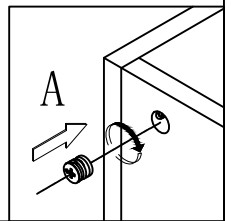

STEP 22

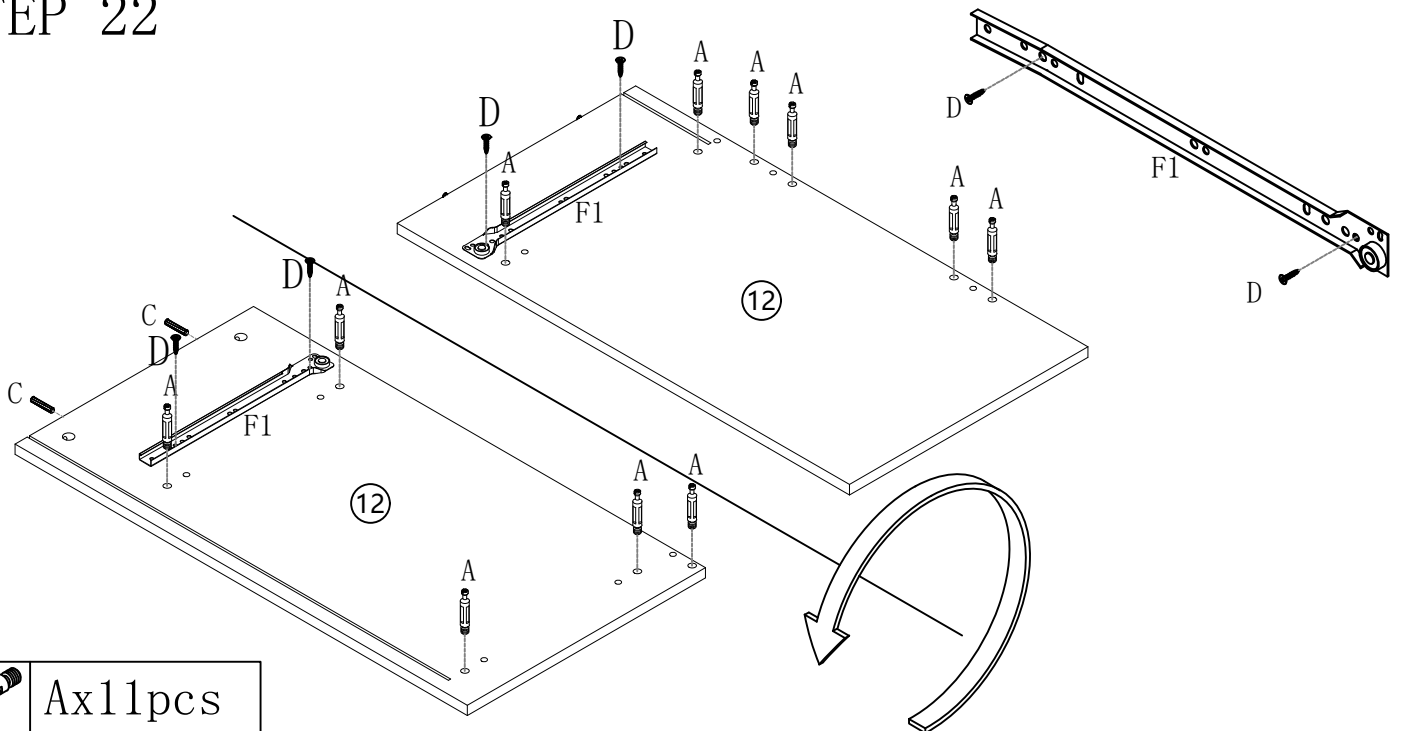

Ax11pcs

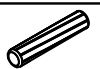

Cx2pcs



Dx4pcs



F1x2pcs

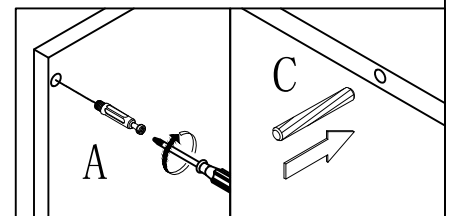

STEP 23

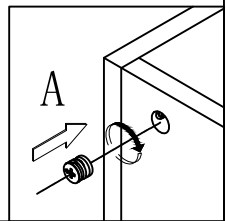
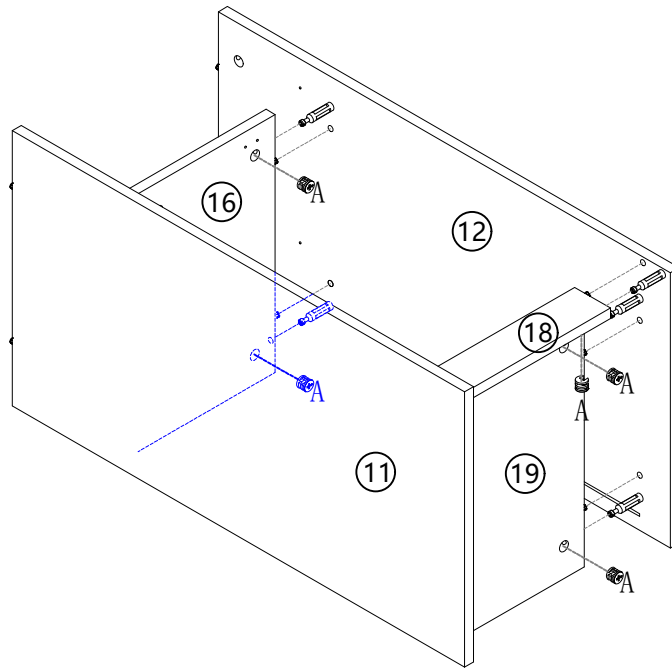

Ax5pcs

STEP 24

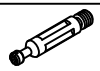
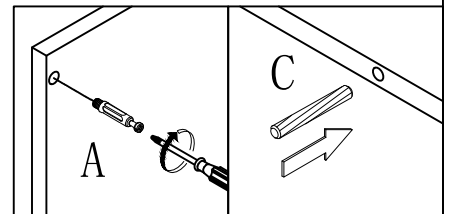
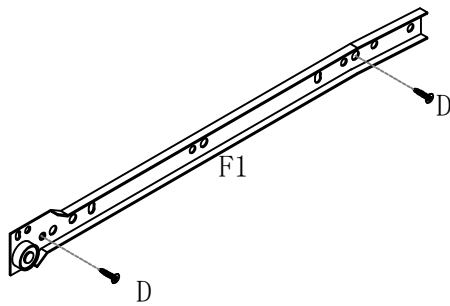
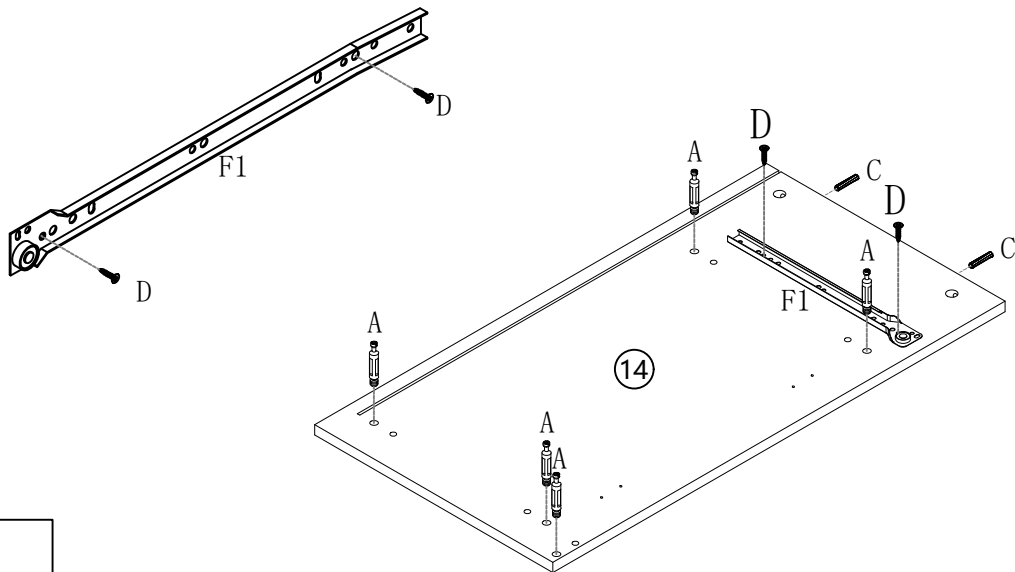

Ax5pcs

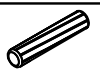

Cx2pcs



Dx2pcs





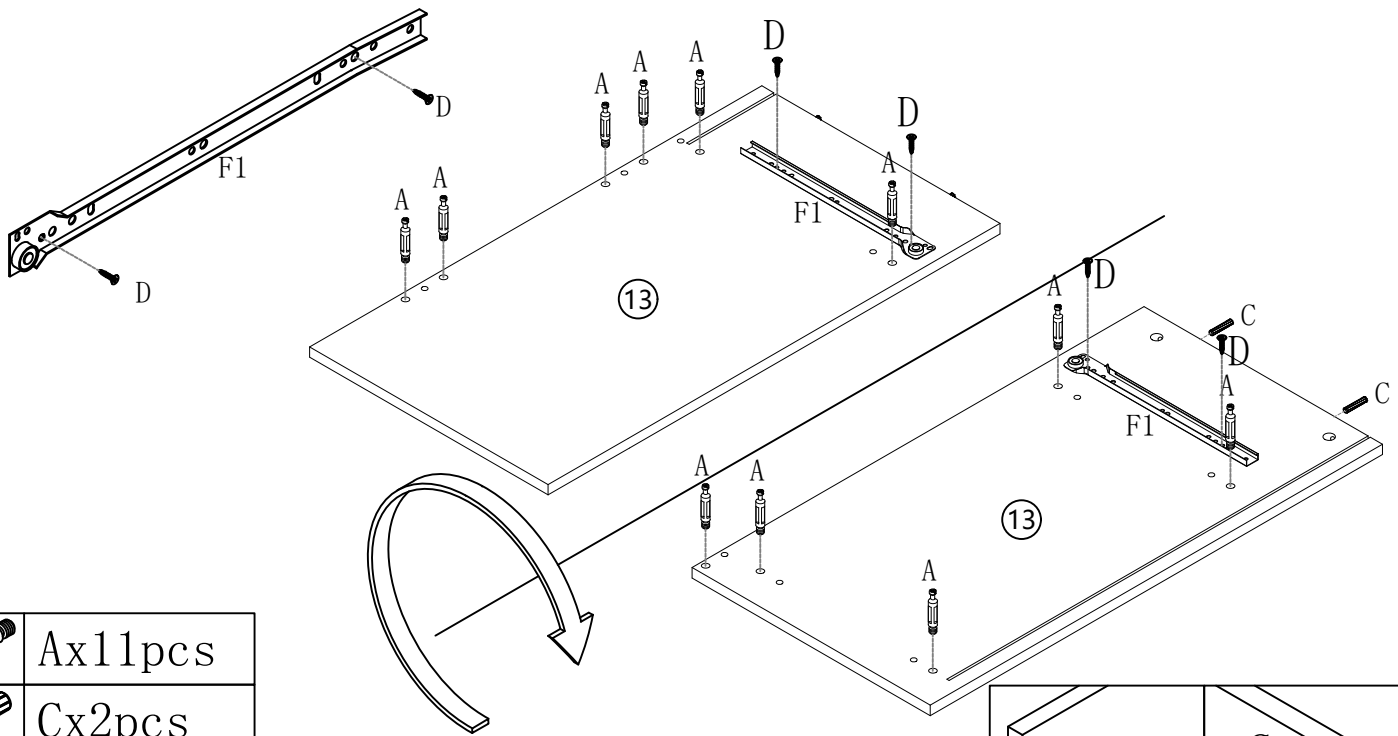

F1x1pcs

Assembly (EN) /Montageschritte (DE)

STEP 25



	Ax11pcs
	Cx2pcs
	Dx4pcs
	F1x2pcs

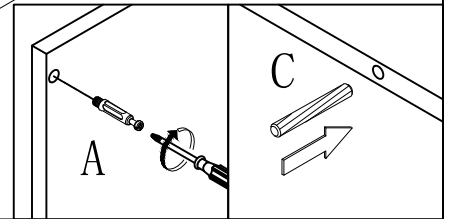

STEP 26

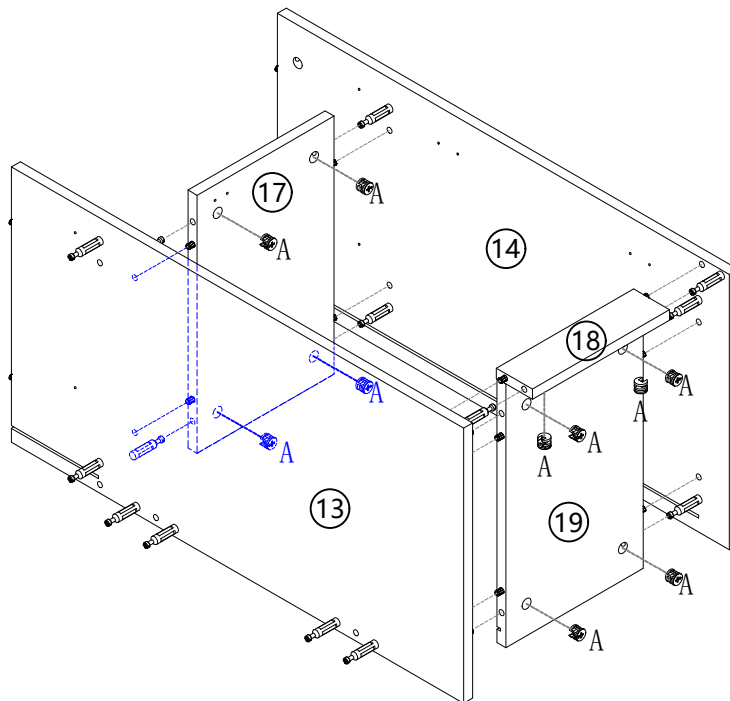

	Ax10pcs
--	---------

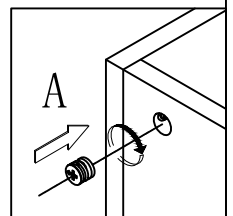

STEP 27

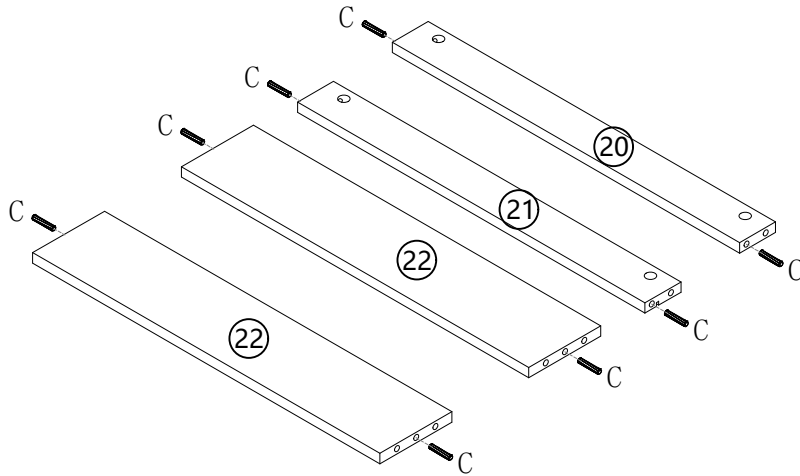

Cx8pcs

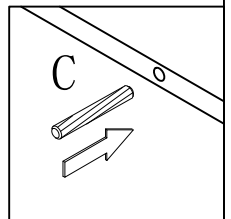

STEP 28

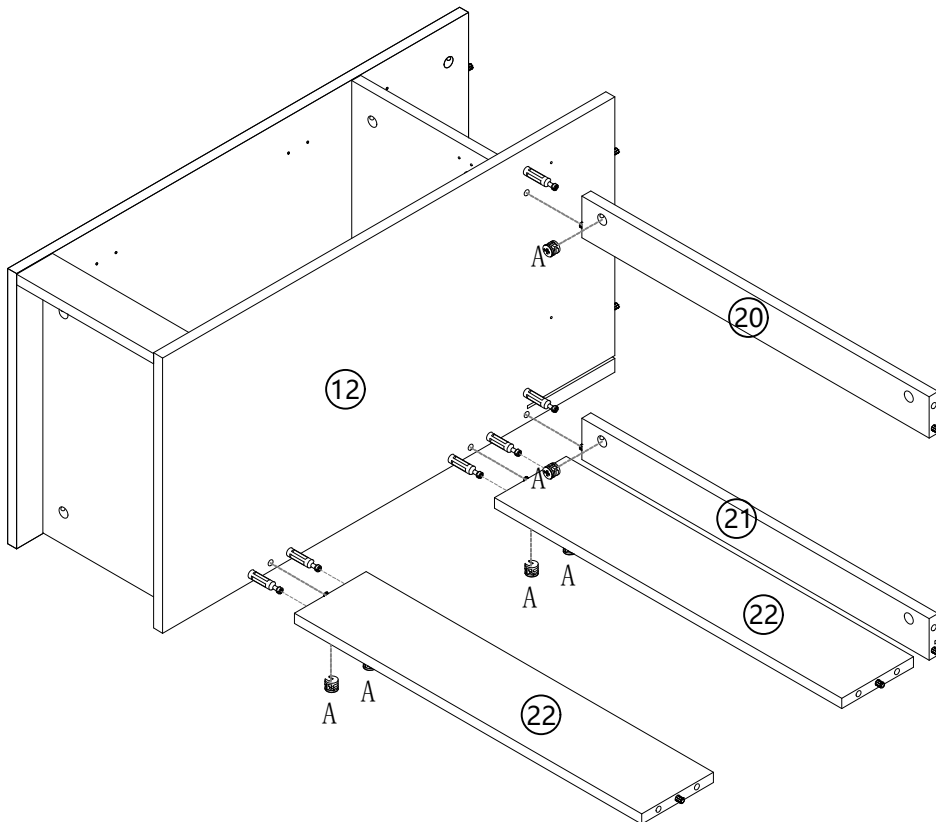

Ax6pcs

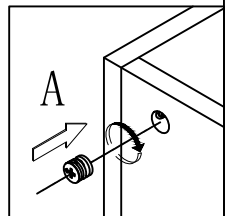

Assembly (EN) /Montageschritte (DE)

STEP 29

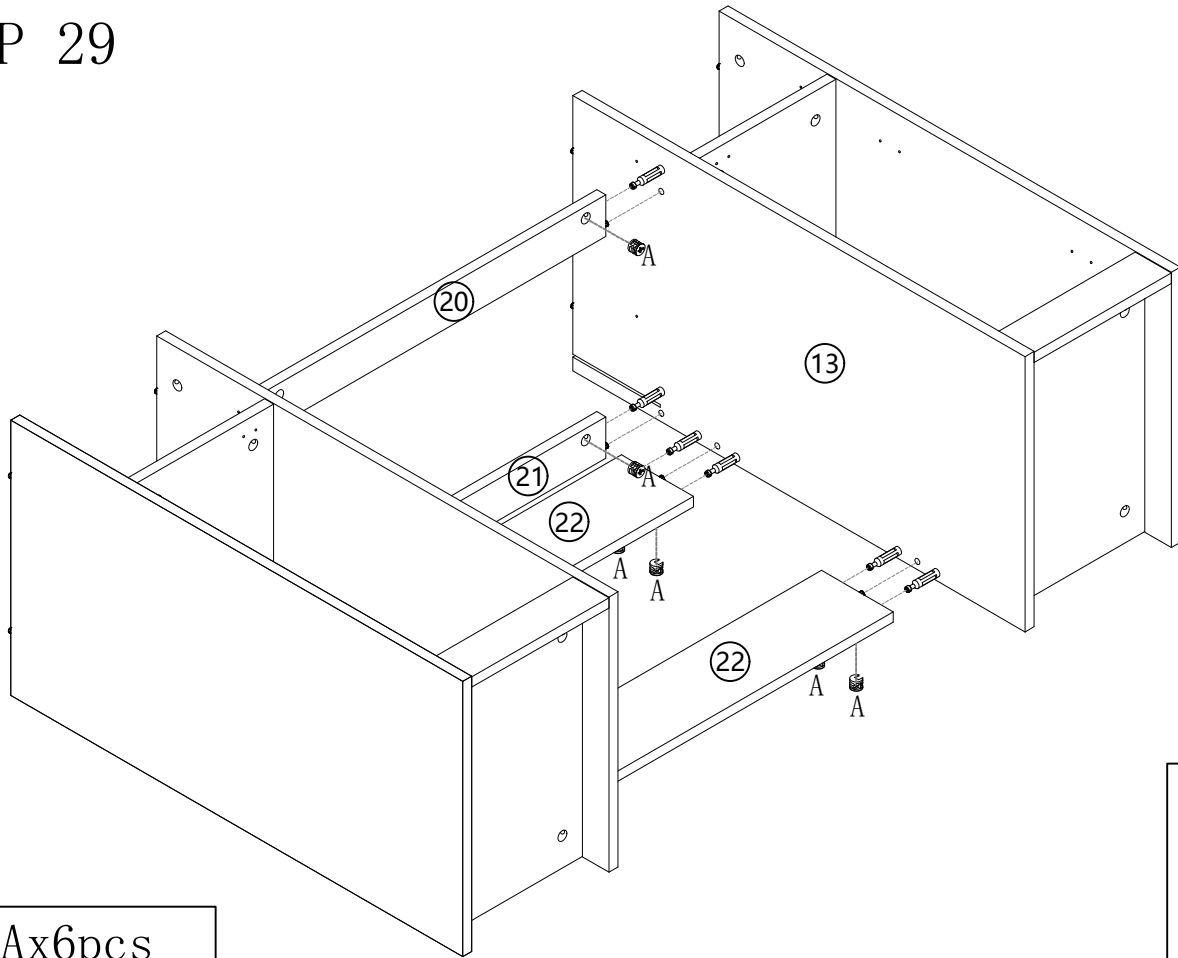

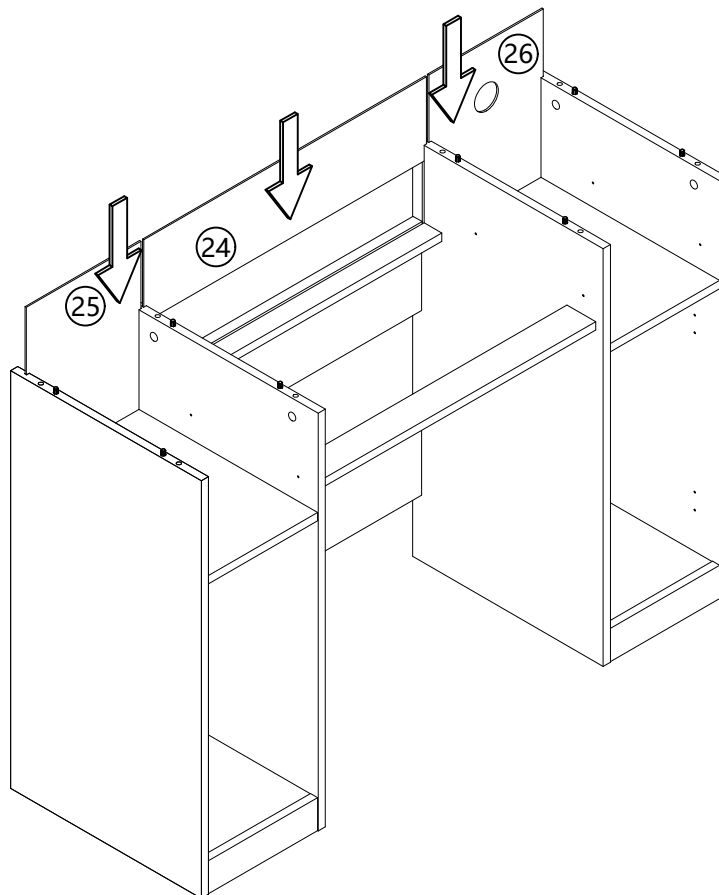

Ax6pcs

STEP 30

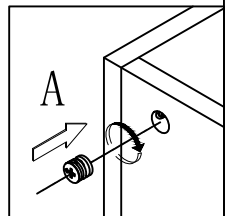
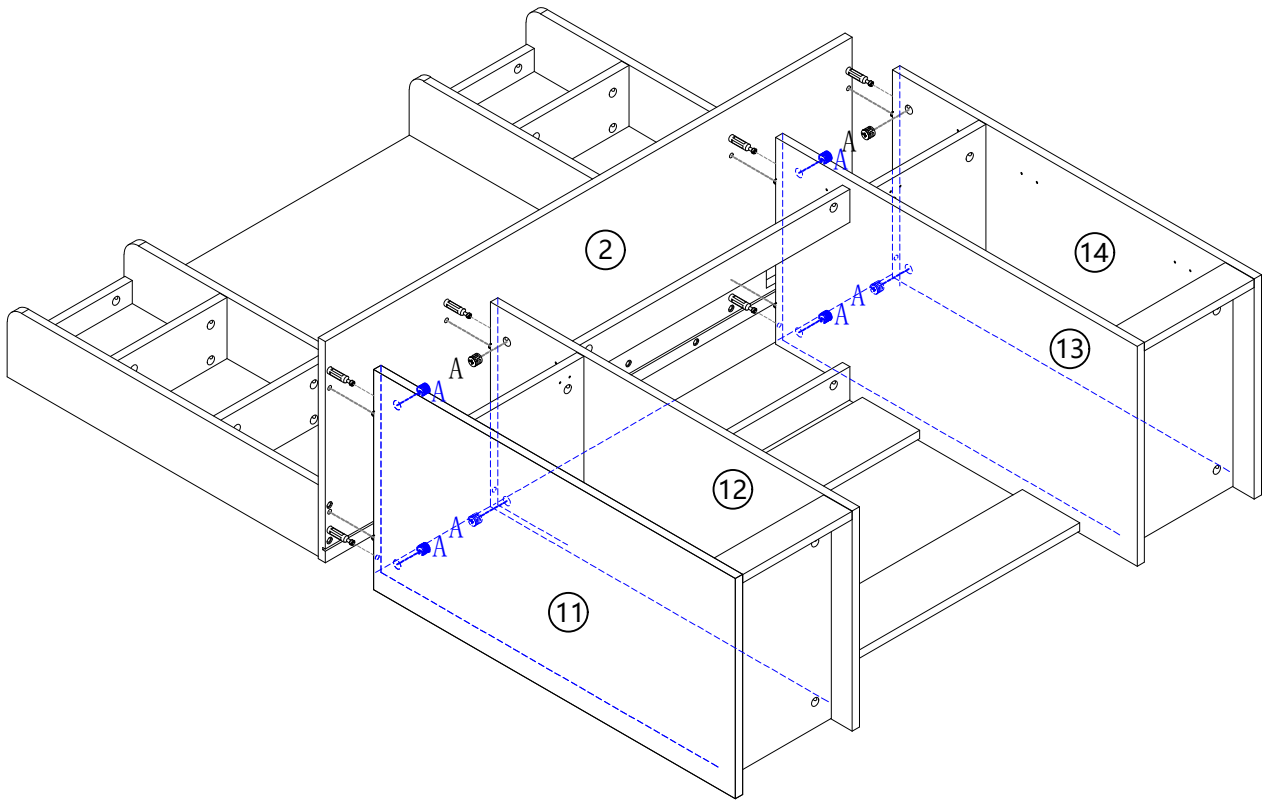

STEP 31



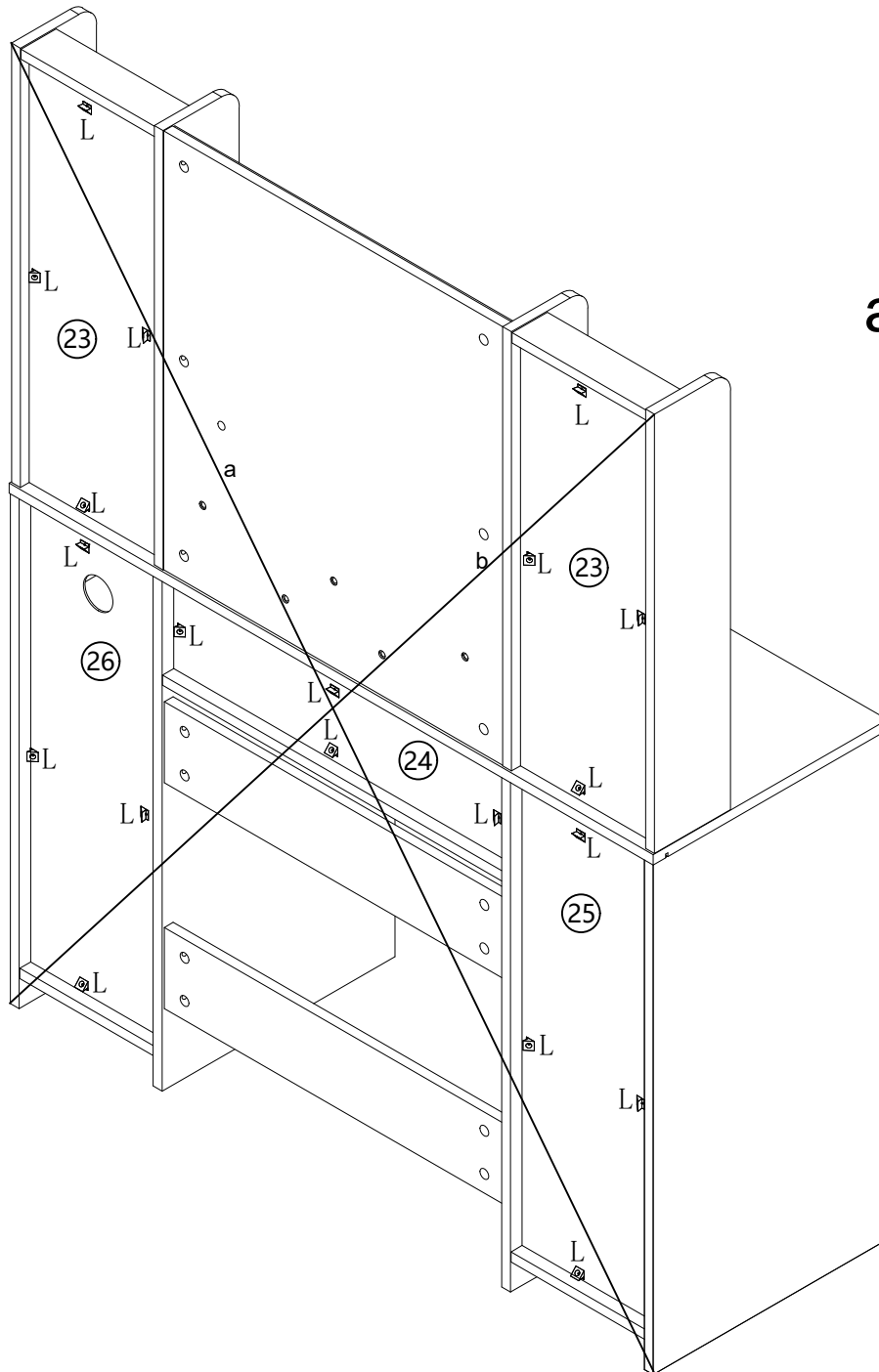

 Ax8pcs

STEP 32



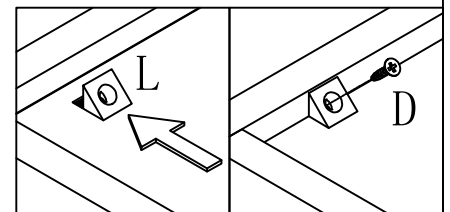

$a=b \checkmark$

	Dx20pcs
	Lx20pcs

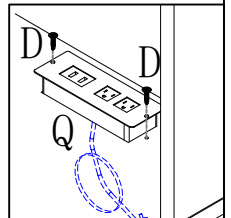
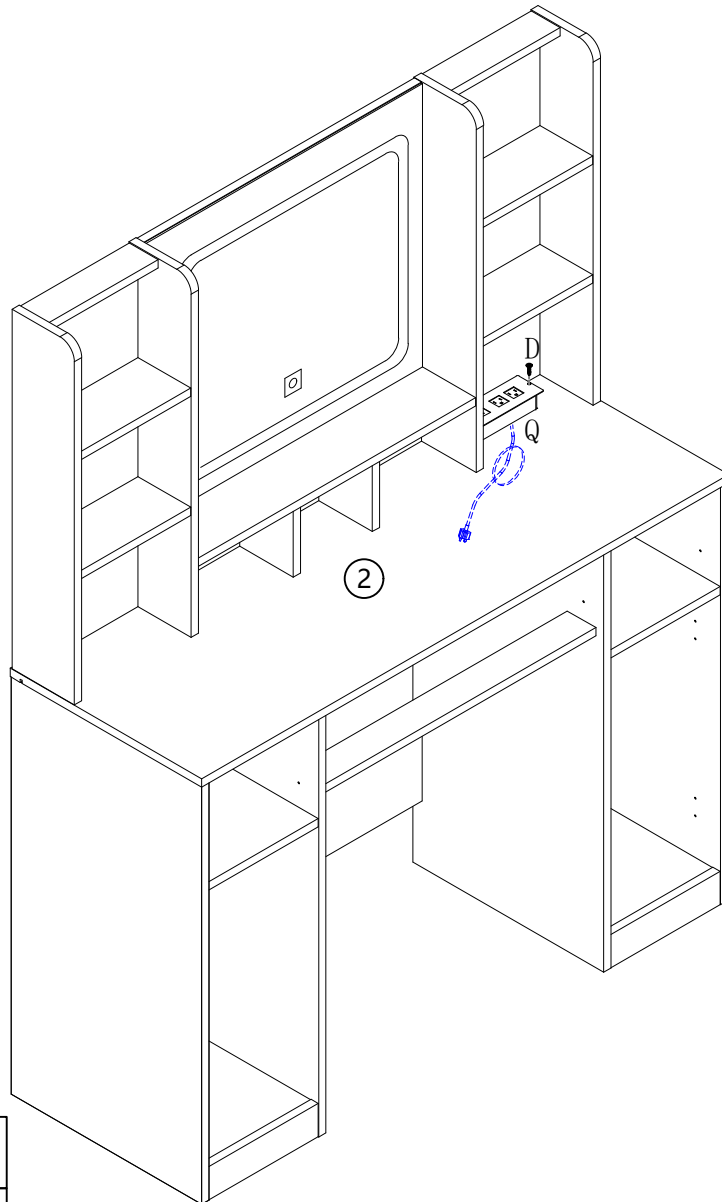

STEP 33



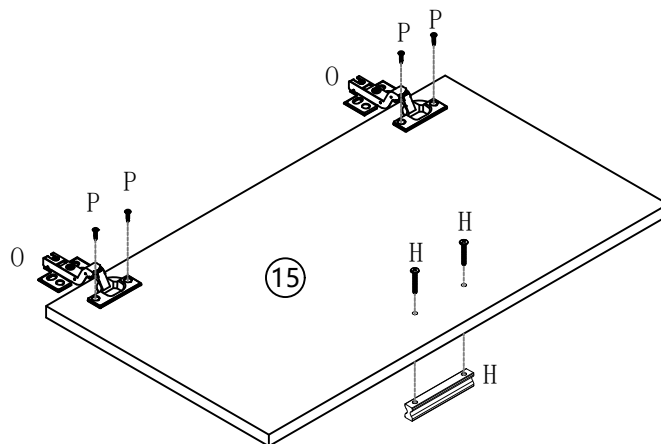

	Dx2pcs
	Qx1pc

STEP 34



x2

	Px8pcs
	Ox4pcs
	Jx2pcs

STEP 35

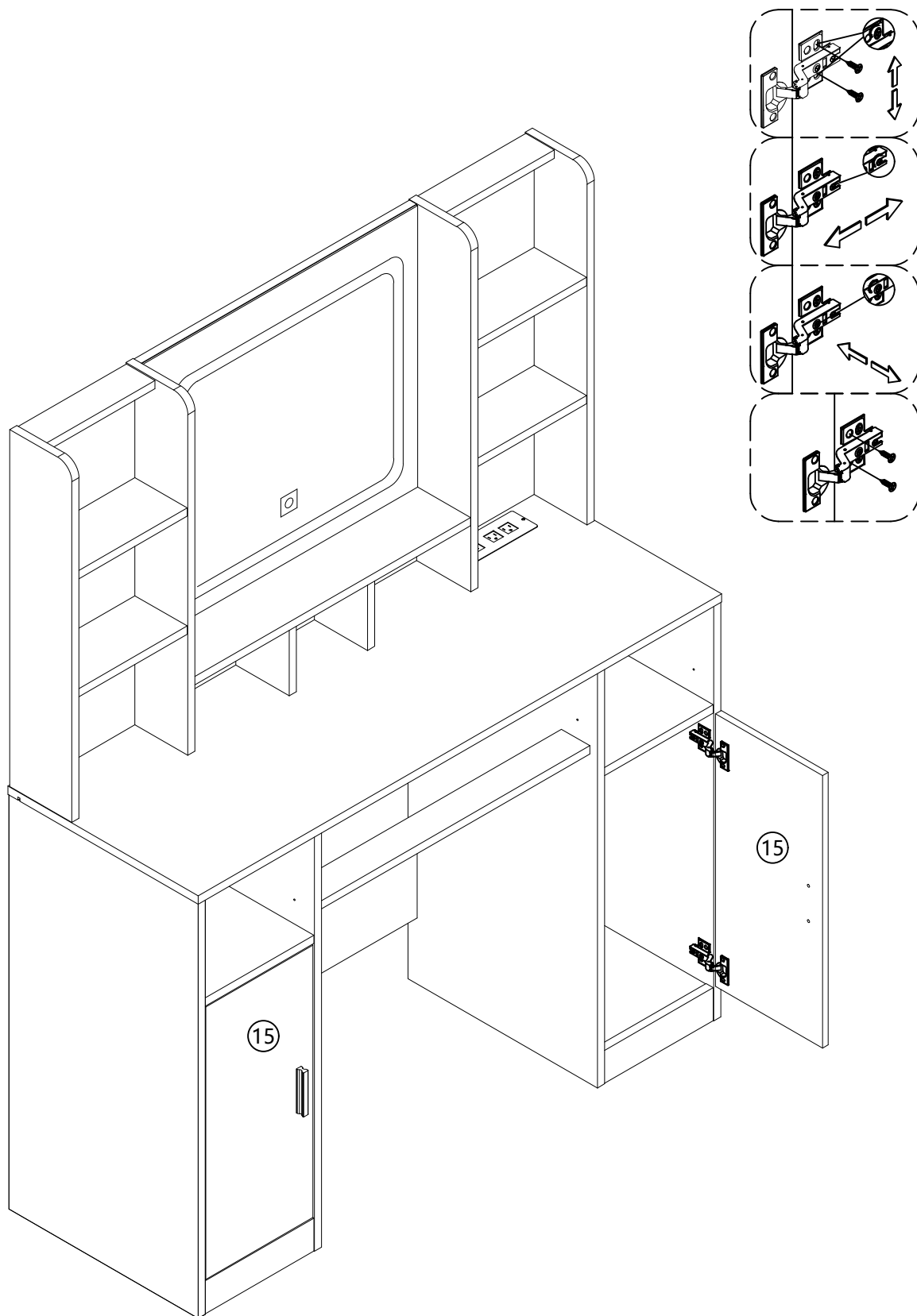



Dx16pcs

Assembly (EN) /Montageschritte (DE)

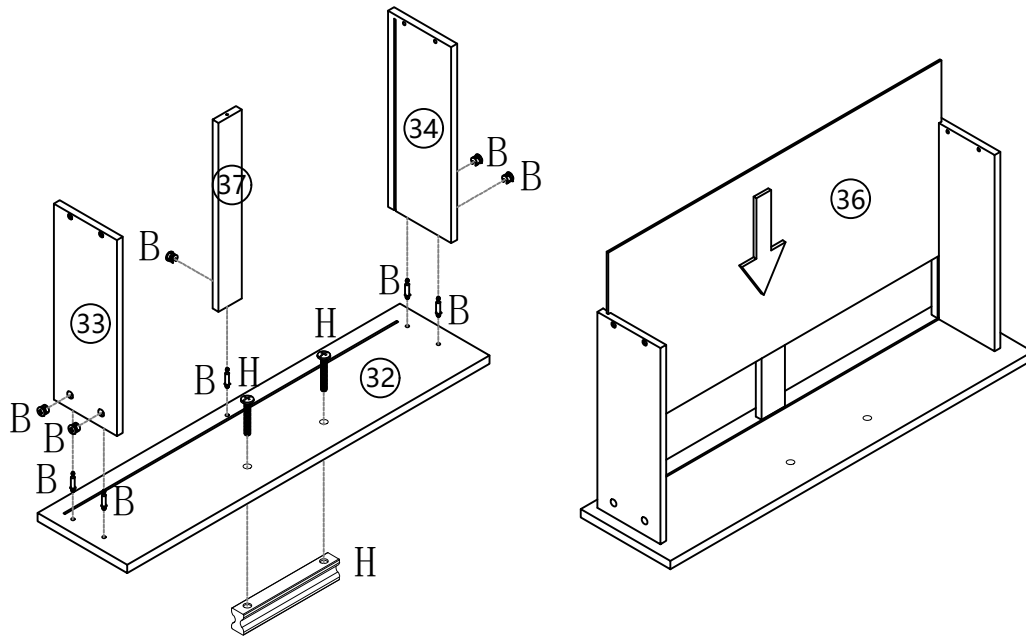
STEP 36



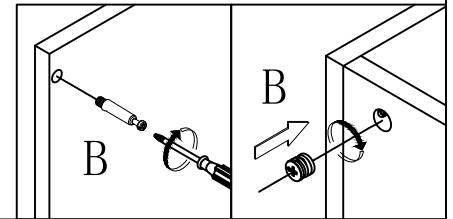

	Hx1pcs
	Bx5pcs
	Bx5pcs

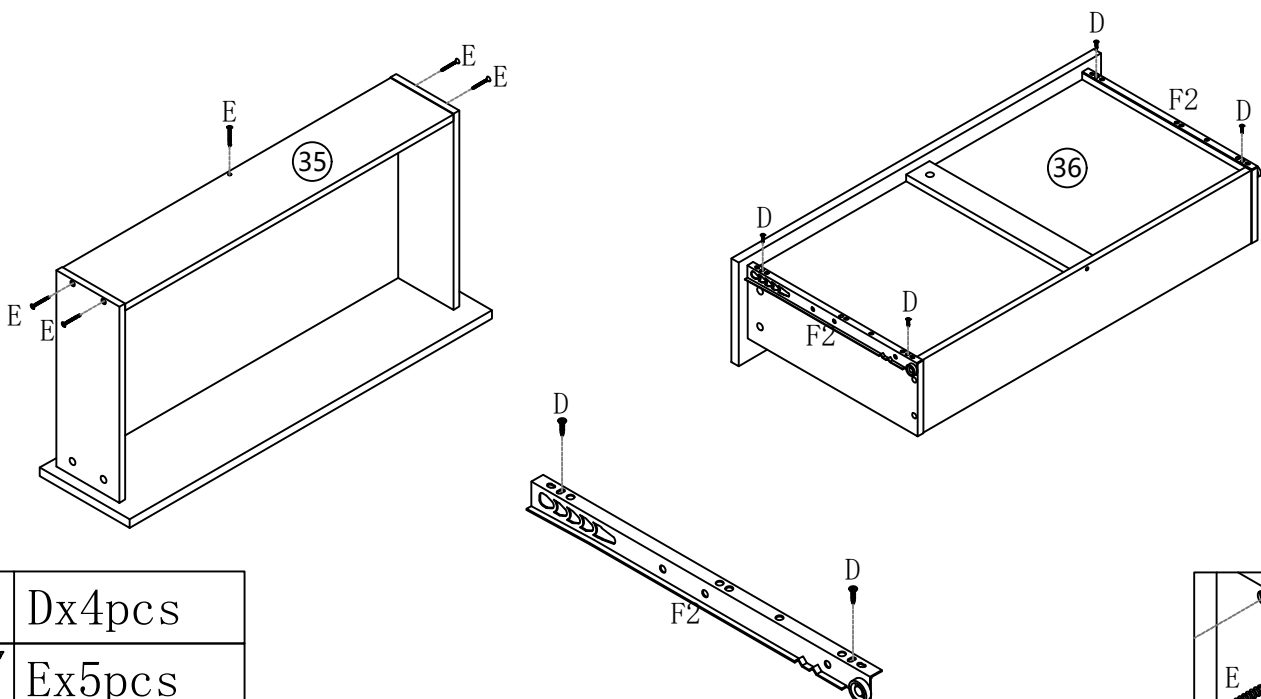

STEP 37



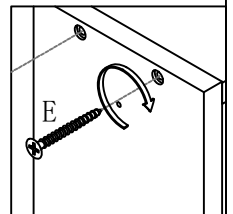

	Dx4pcs
	Ex5pcs
	F2x2pcs

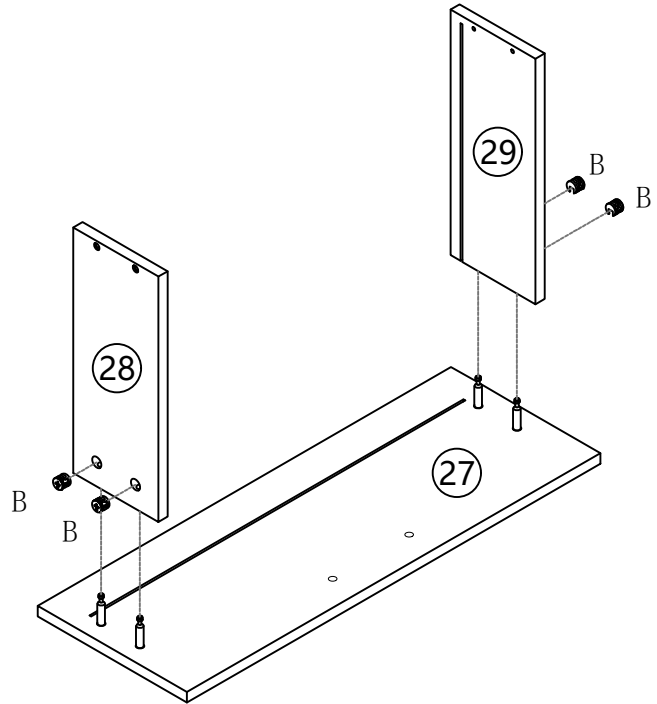
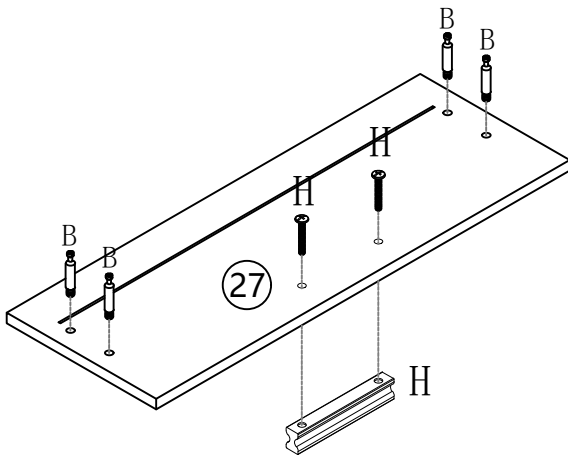

STEP 38



	Hx2pcs
	Bx8pcs
	Bx8pcs

x2

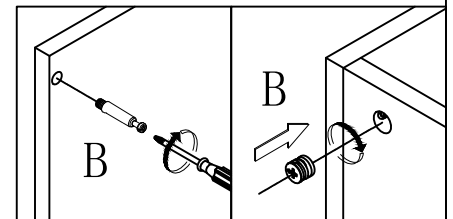

STEP 39

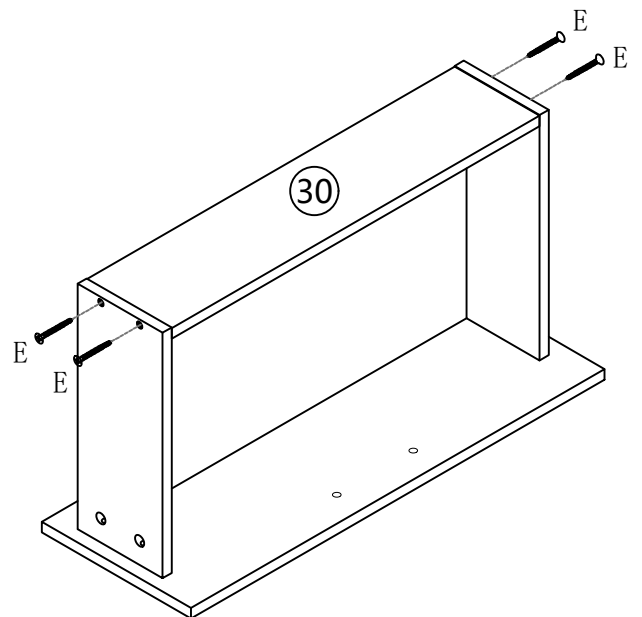
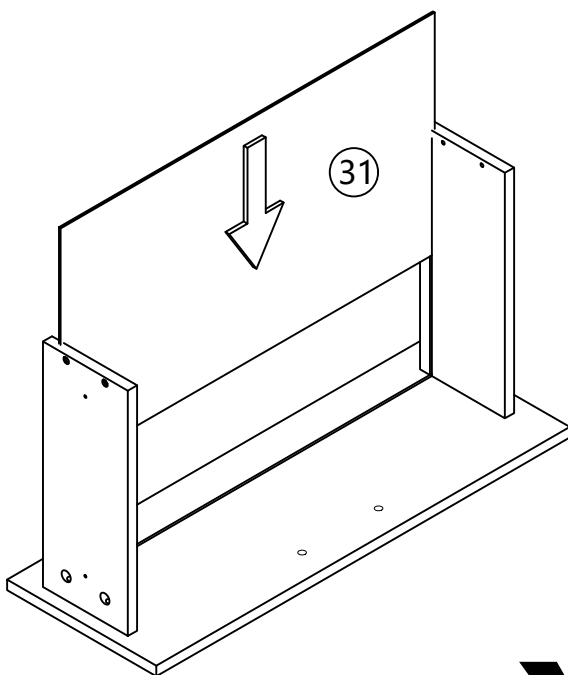

x2

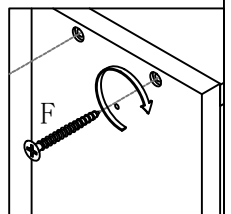

	Ex8pcs
--	--------

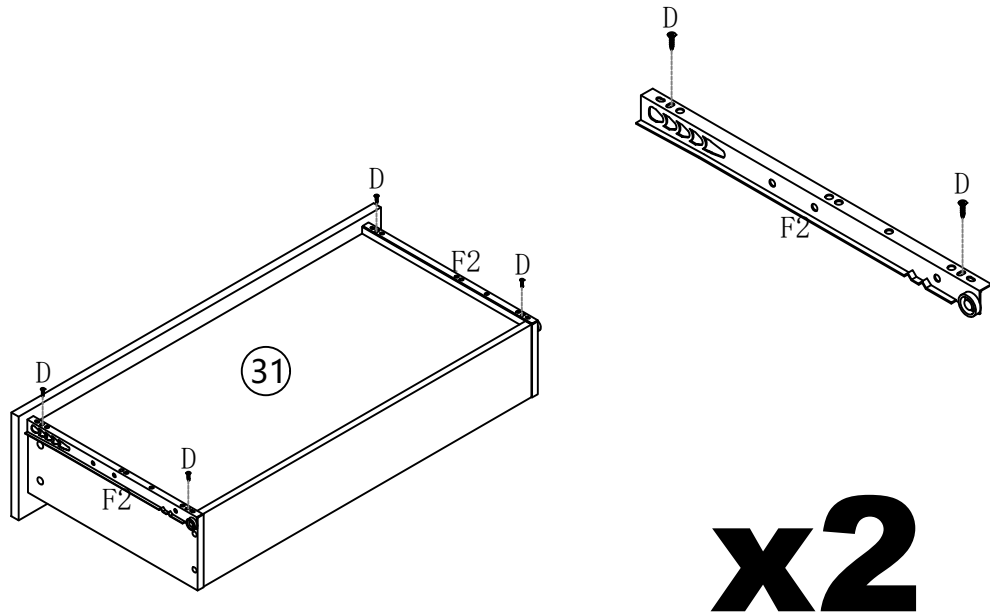

Assembly (EN) /Montageschritte (DE)

STEP 40





	Dx8pcs
	F2x4pcs

STEP 41

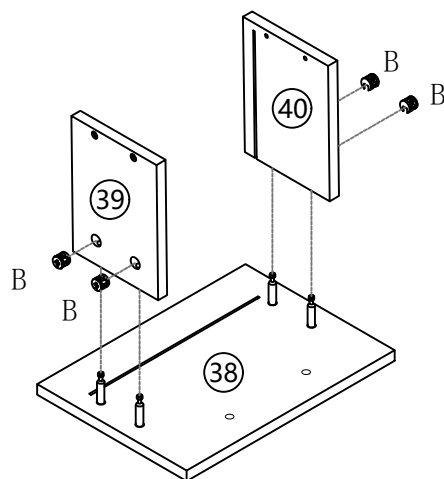
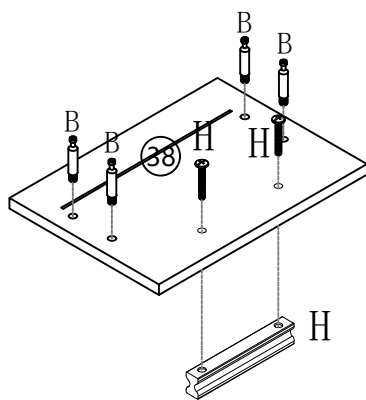
x2



	Hx2pcs
	Bx8pcs
	Bx8pcs

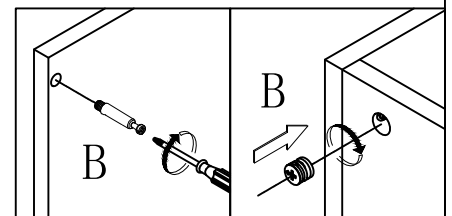

STEP 42

x2

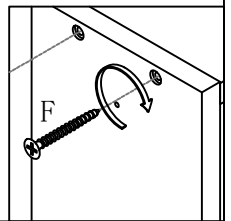
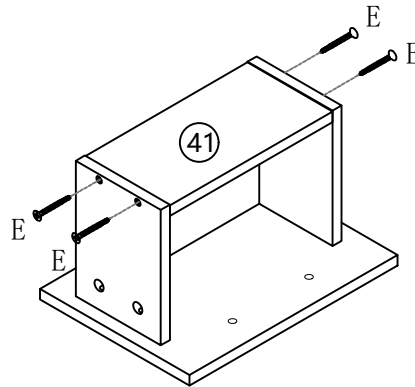
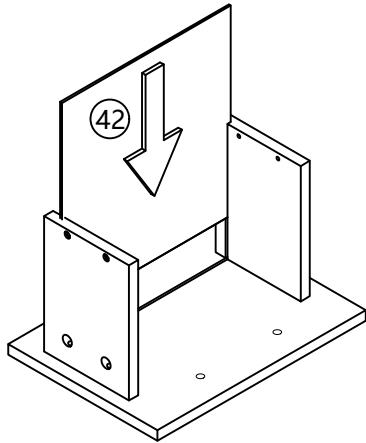

 Ex8pcs

STEP 43

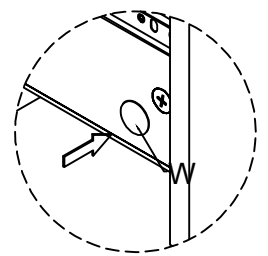
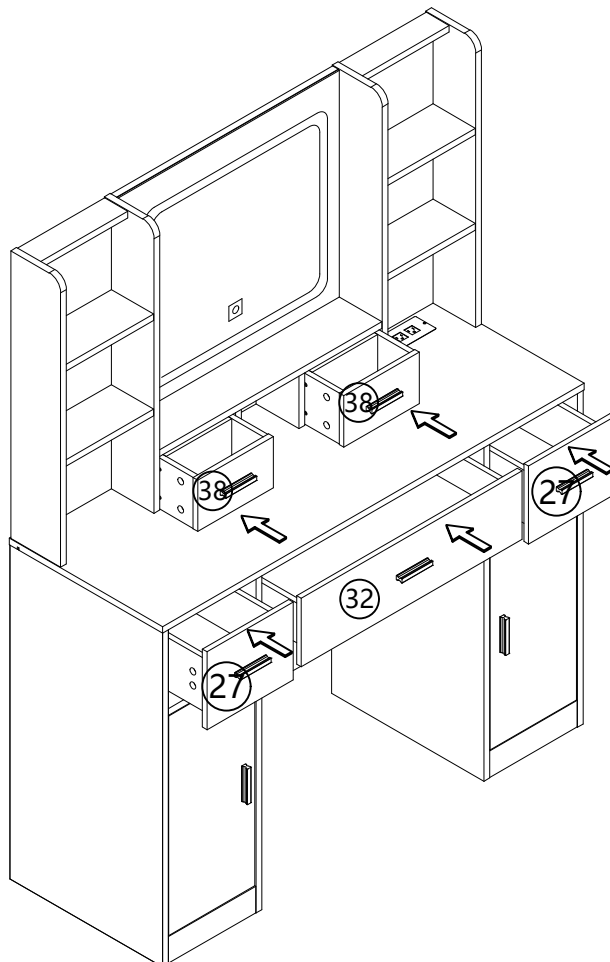



In order to make the product more beautiful, please paste hardware W on the exposed holes

 Wx99pcs

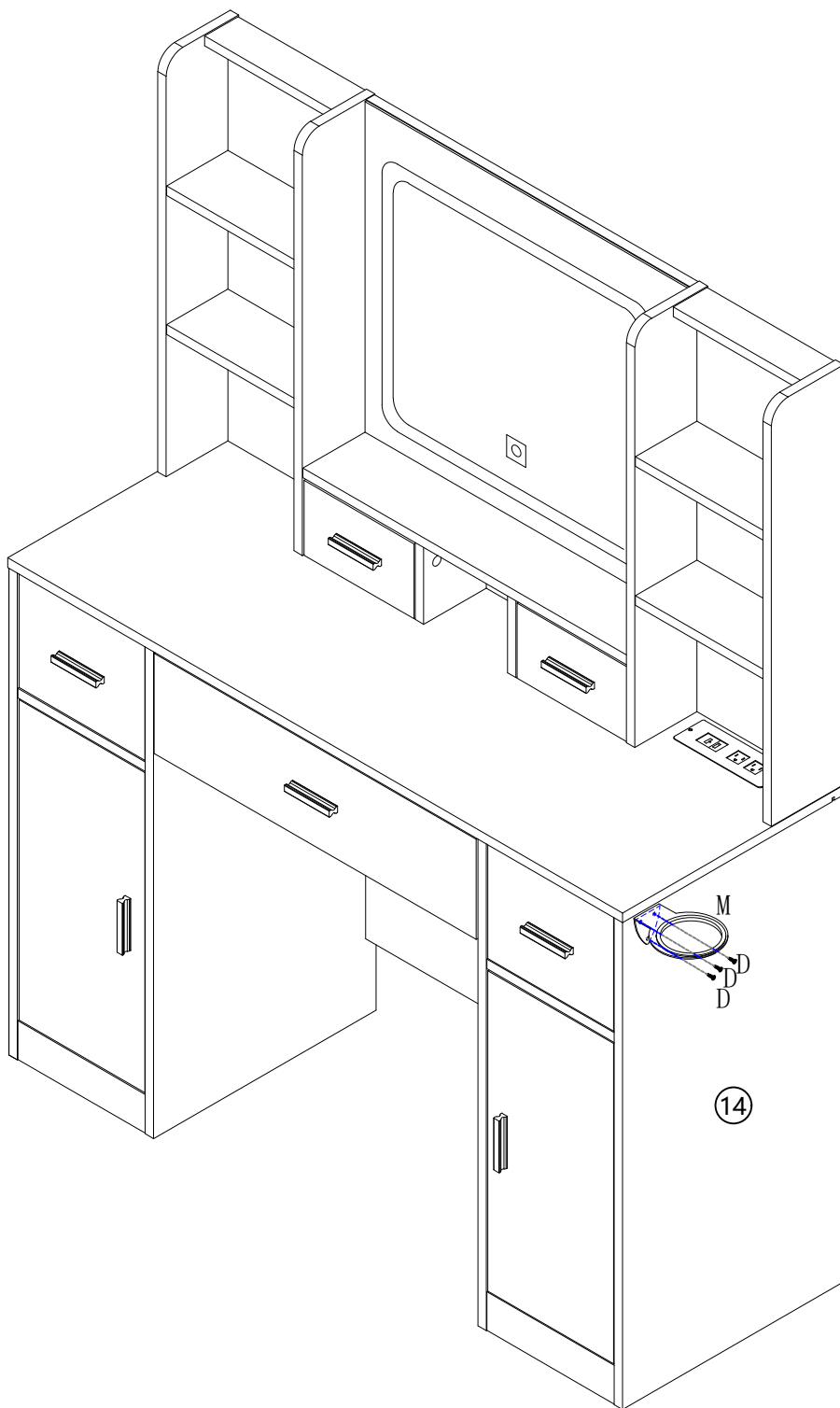
STEP 44



	Dx3pcs
	Mx1pc

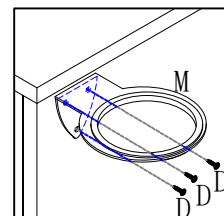

STEP 45

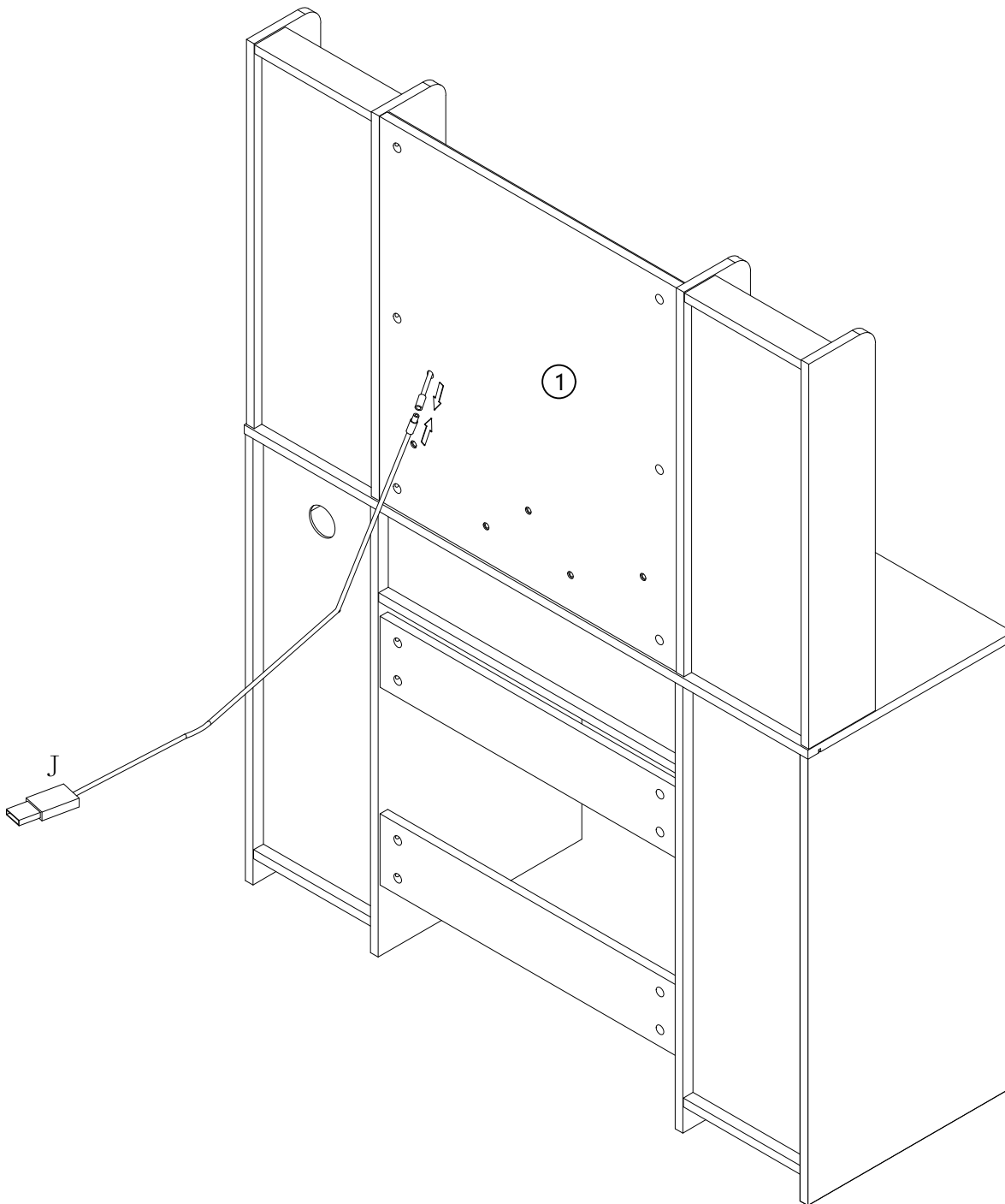

Jx1pc

Assembly (EN) /Montageschritte (DE)

STEP 46

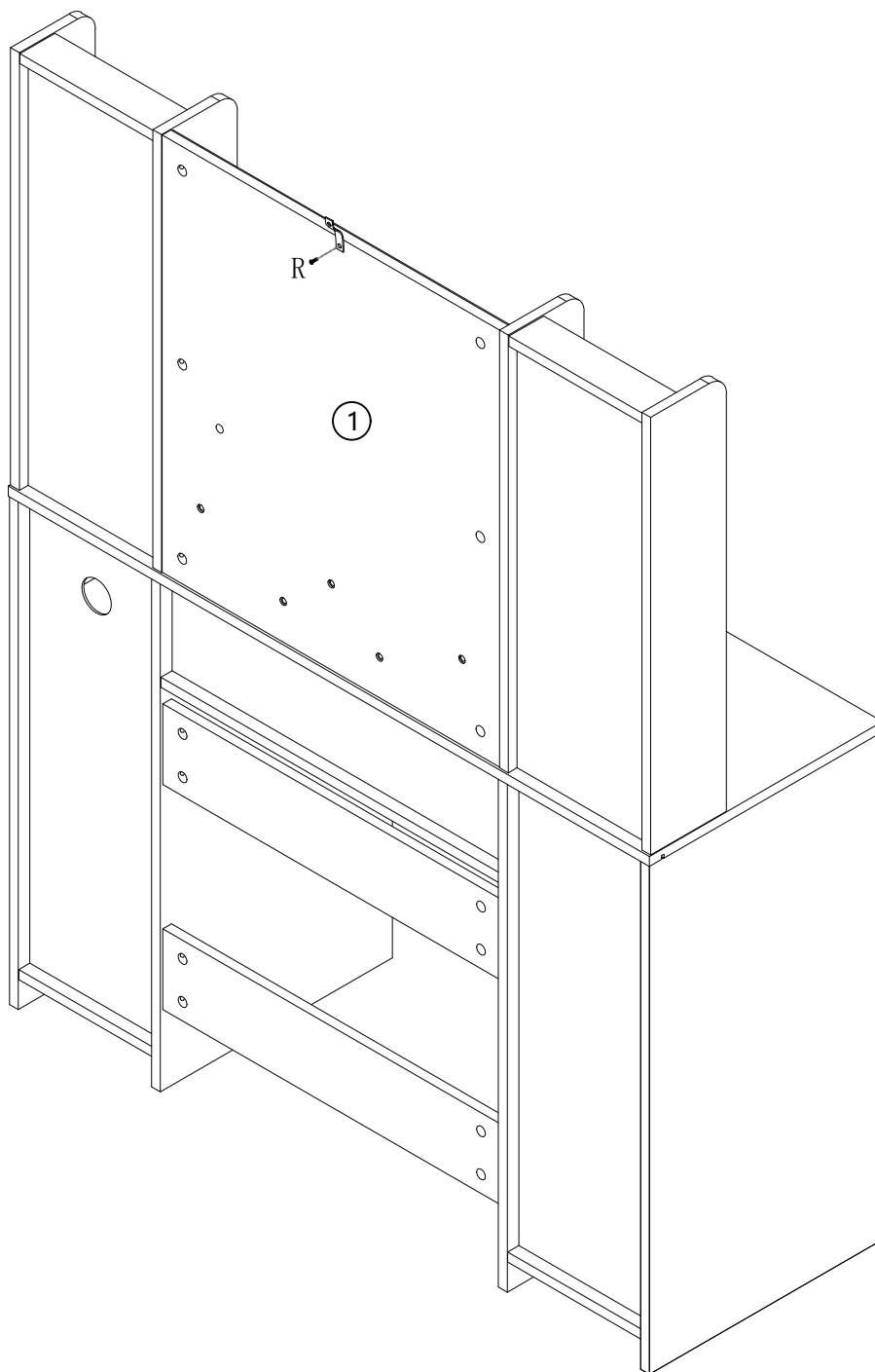
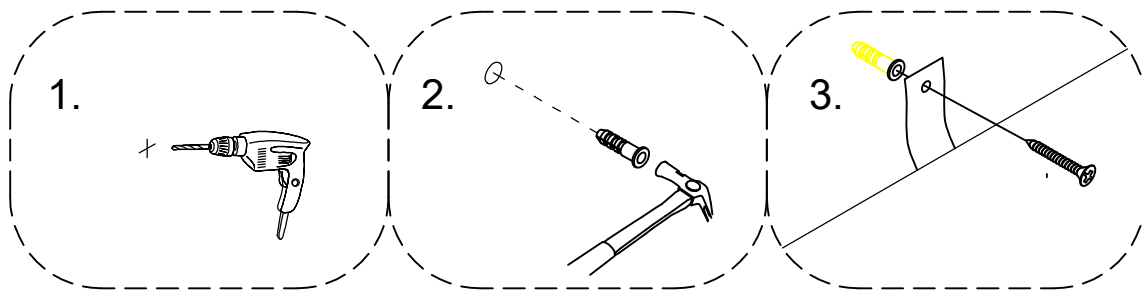

 Rx1pcs

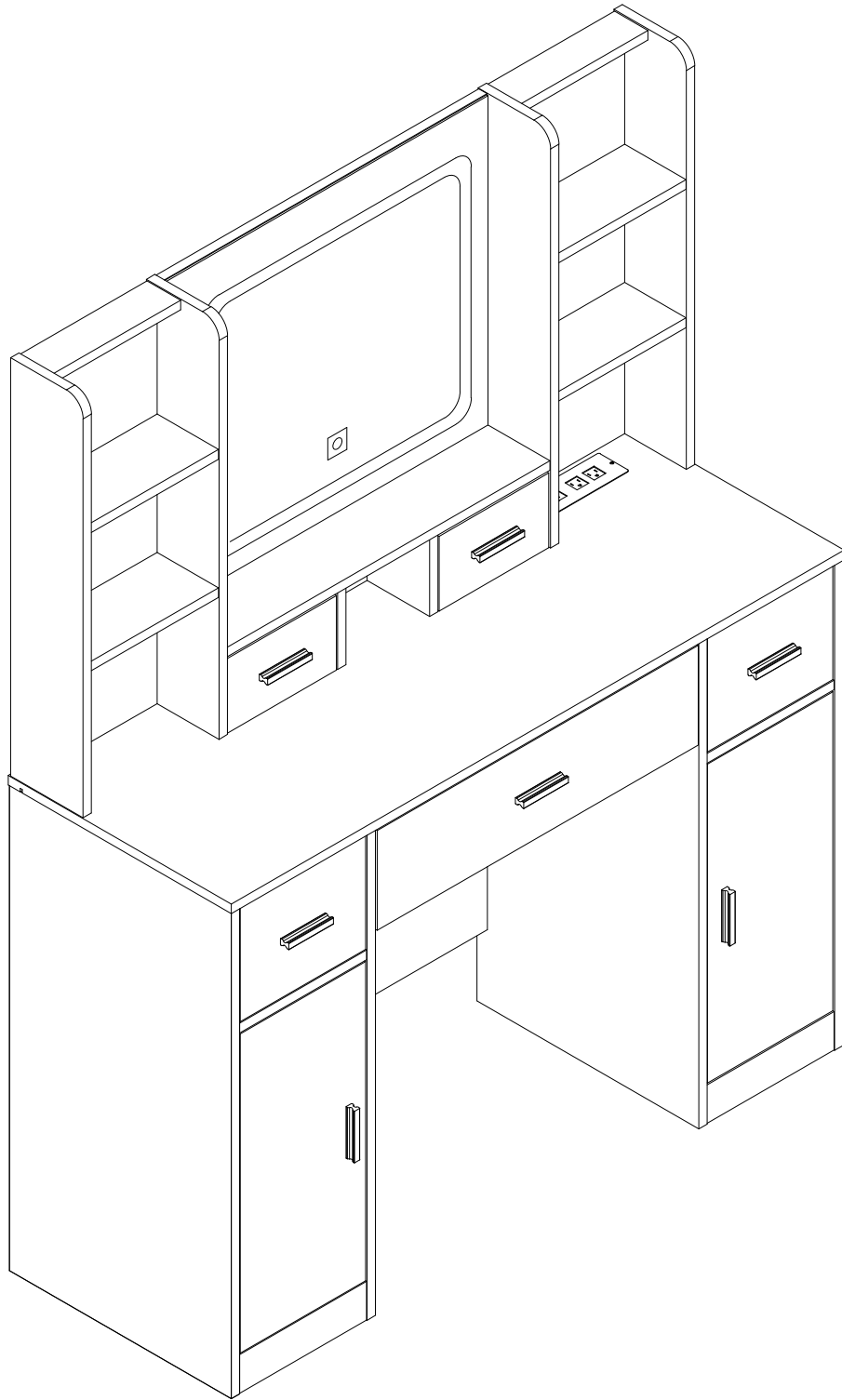

Made in China