

Assembly Instructions

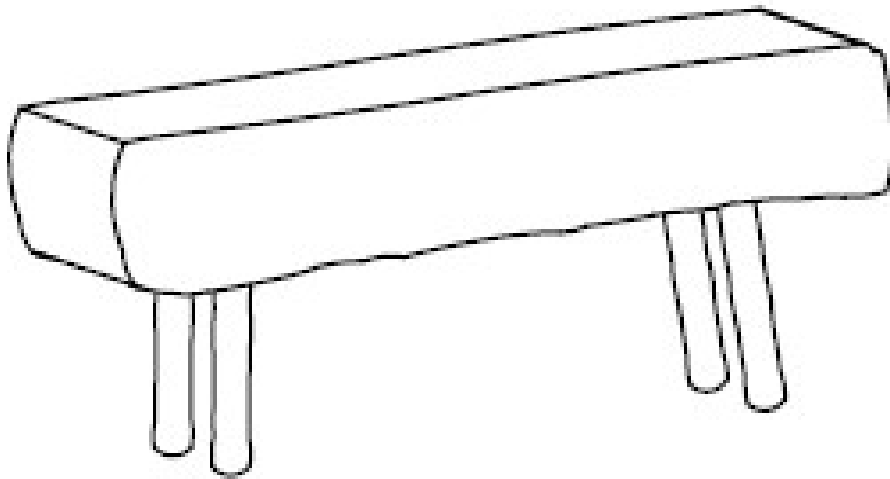

Caution : You must read this before you proceed

BENCH

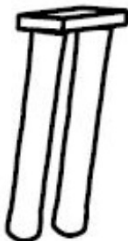

Parts List

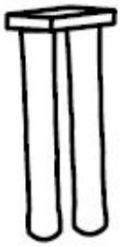
Label	Picture	Description	QTY
A		Left leg	1

B		Right Leg	1
C		Top	1

Hardware

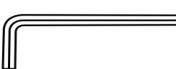
Label	Picture		QTY
①		Bolt(M8*64mm)	9
②		Allen Key	1

Assembly Preparation

Before Beginning Assembly:

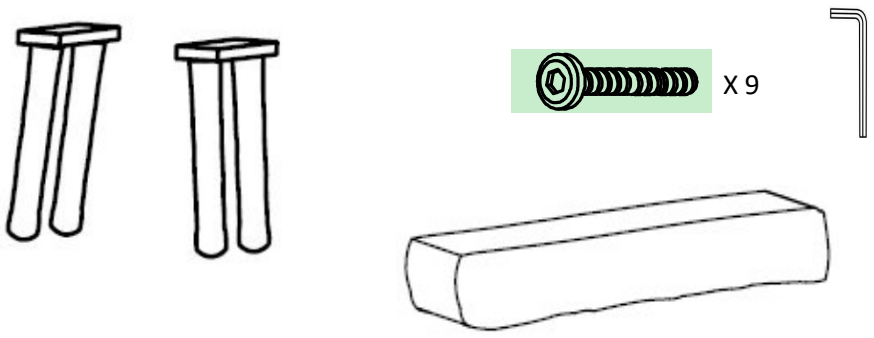

- Read instructions, cover to cover-



- Have 2 adults on hand for assembly-



- Do not assemble on flooring or carpet-



- Assemble on a clean non-marring surface (packing foam)-



- Save all packaging until finished-

Assembly Steps

Overview

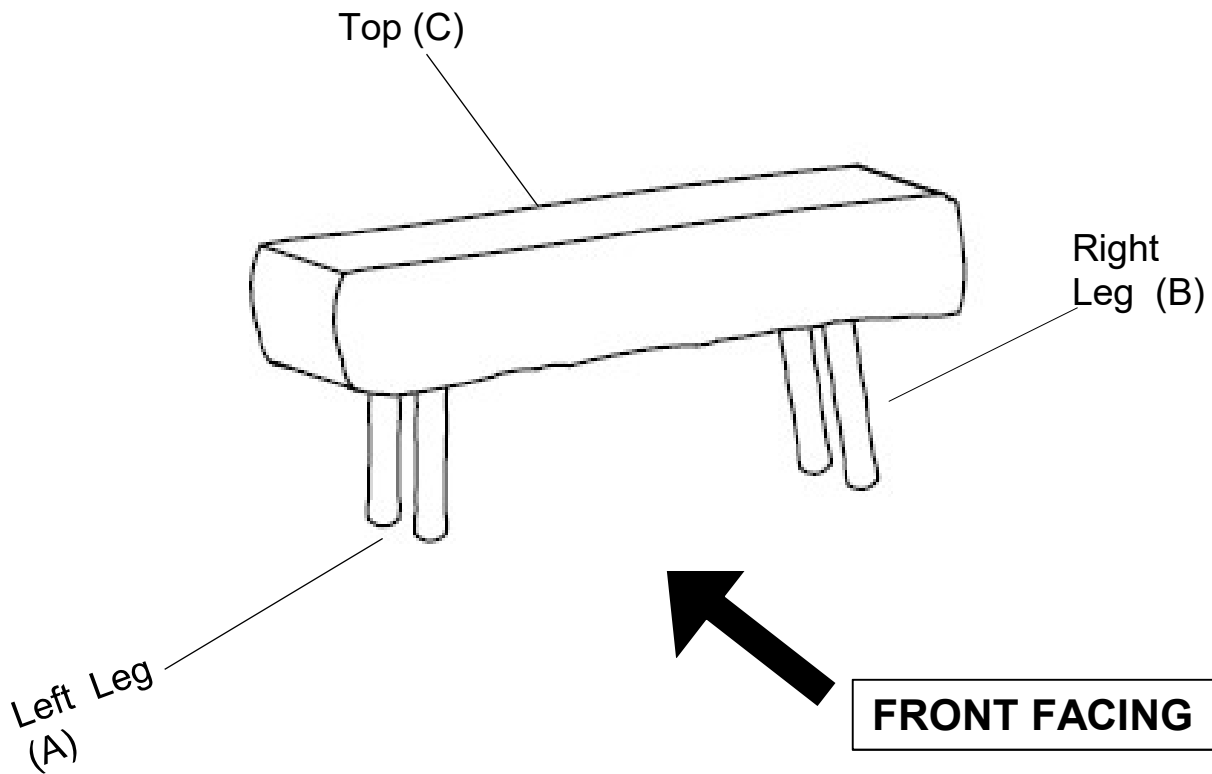

This bench has multiple parts and may require up to 30 mins to assemble. To give you an overview of the bench parts, the above picture is to help you put the various parts into perspective. Please read through the instructions herebelow to familiarise the parts and steps before assembly.

Step 1

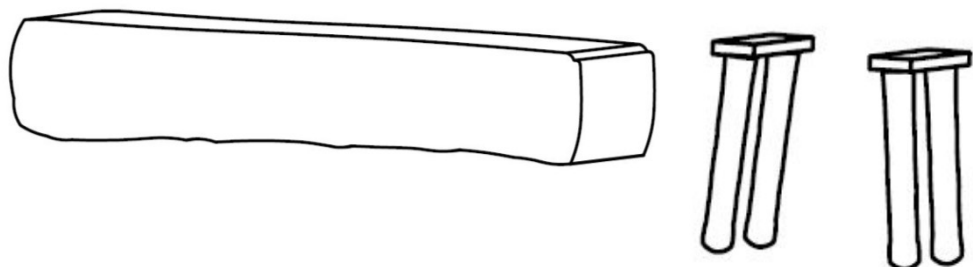

Unpack and place all parts on a clean, non-marring surface.

Step 2

NOTE : Each leg numbered.
Please match according to respective markings.

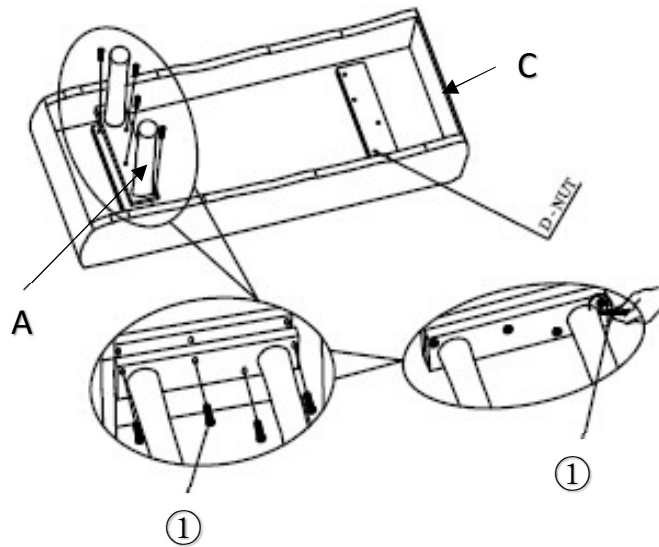

Place the Top (C) with its one side face skywards onto a clean, soft surface to avoid any scratches or damages to the product. Align the tenon of Top (C) into the Mortise of Left Leg (A) as shown above.

Then, affix the Top (C) with Left Leg (A) by using Short bolt (1) and Allen Key (2).

DO NOT FULLY TIGHTEN BOLTS.

Step 3

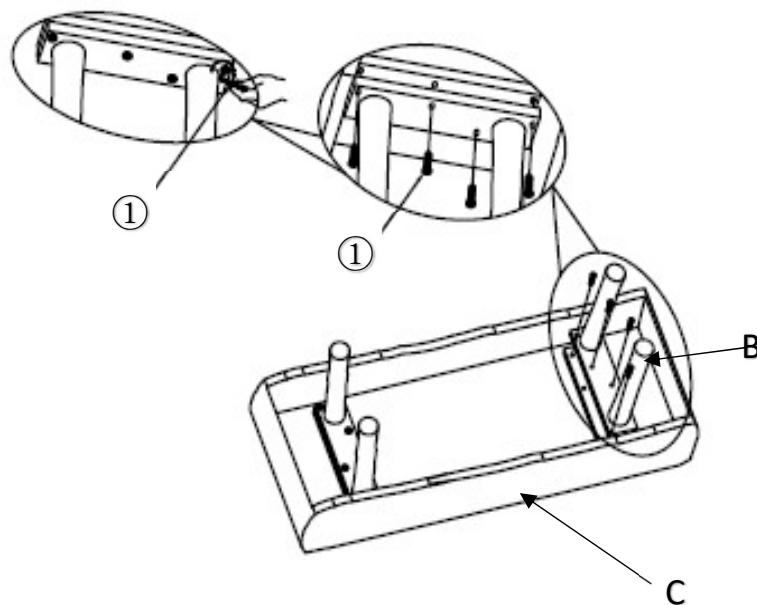

Then continue position Top (C) as shown in picture above.
Align the wooden dowel into the positions in the Legs.
Then, affix the Right Leg (B) with Top (C) by using Short blots (①)
and Allen Key (②)
DO NOT FULLY TIGHTEN BLOTS.

Step 4

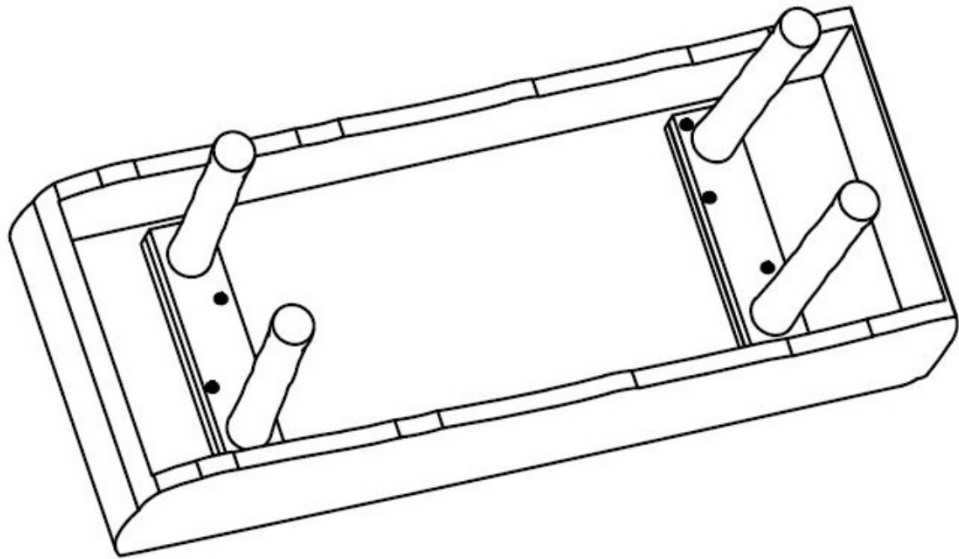

With the help from your partner, turn the bench to rest on Top (C)
so that Right Leg (B) is now facing skywards.
Repeat the same process by affixing Blots (①), (②) to designated
points.
LOOSELY TIGHTEN ALL BLOTS.

Step 5

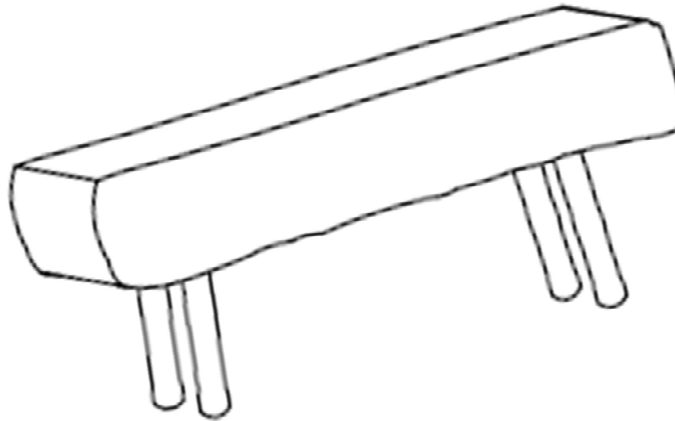

Turn the bench right side up.

Place the bench on a **LEVEL SURFACE**.

Inspect it and make sure all parts are adequately connected.

Gently and gracefully, sit into to the bench.

This would help to align all the parts at all the joint areas.

Then get off the bench, and in a sequential manner, proceed to tighten all blots.

To tighten the blots at the base of Top, do secure assistance from your adult partner(s).

You may be required to turn the bench, to gain easy access to the secure points.

Turn the bench in a synchronised manner.

CAUTION 1: When tightening these blots, tighten sequentially.

DO NOT tighten any blots fully and then towards the next one. This would cause the frame to warp.

If there is still wobbles, loosen the blots and execute this same process.











WARNING!! IF BENCH IS NOT STABLE , IT COULD LEAD TO DAMAGING THE PRODUCT.

Ensure all blots are fully locked into position.

The bench is ready to be used.

Caution 2: This bench can only be used on a flat, level surface.

Care & Maintenance

- ⊘  ● Do not put hot items directly on furniture surface
 - ⊘  ● Do not clean furniture with harsh cleansers or polish.
 - ⊘  ● Do not place furniture under direct sunlight.
 - ⊘  ● Do not place furniture near heating or cooling vents.
 - ⊘  ● Do not write on furniture without a padded barrier to protect the surface.
 - ⊘  ● Do not place furniture outside. For indoor use only.
 - ⊘  ● Not for commercial use. For residential use only .
 - ⊘  ● Stains may be removed with mild soap solution and damp cloth.
 - ⊘  ● Children should not climb or jump on the furniture.
-
- ✓  ● Dust and pick-up spills using a clean, non-colored, lint-free cloth .