

# ASSEMBLY INSTRUCTIONS

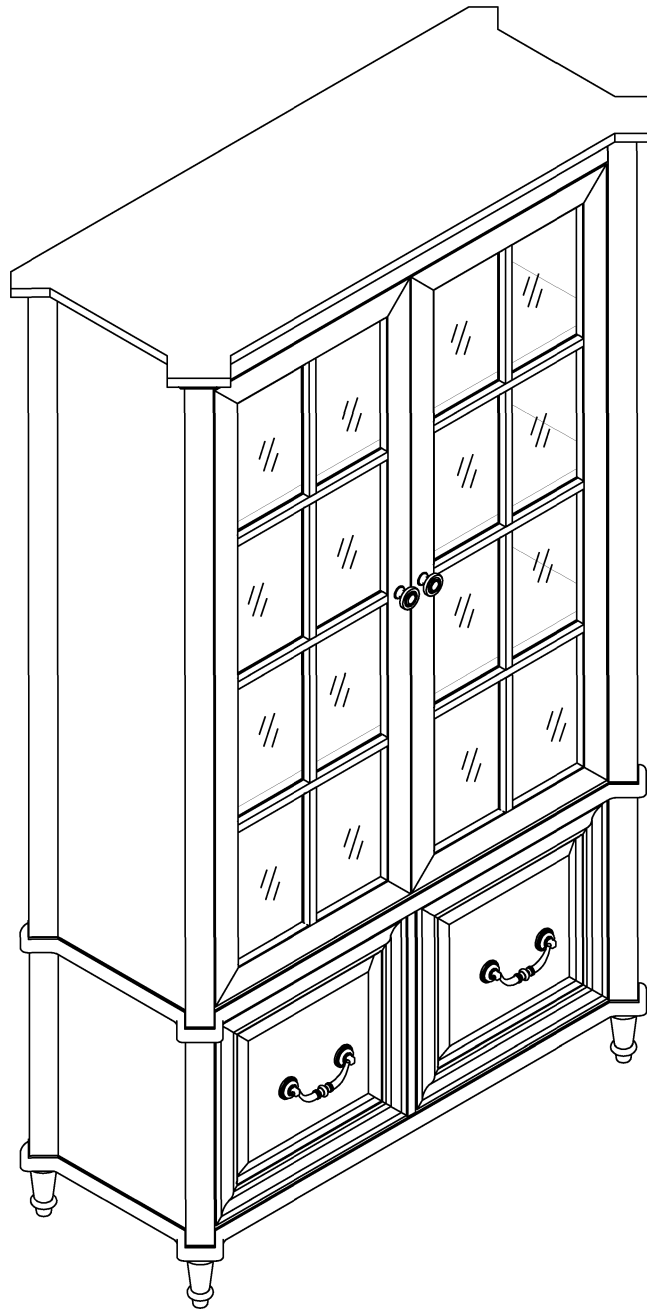

**SAFETY TIPS:** Static charge may cause dust on foam – clean with a dry or damp cloth. Small foam strands may be present – handle gently and dispose of properly. Do not burn or incinerate. Check local recycling guidelines.

# Before You Start

1. Read through each step carefully and follow the proper order.
2. Separate and count all your parts and hardware.
3. Give yourself enough room for the assembly process.
4. Assemble this product on the empty carton or carpet to avoid scratching.
5. Two people are recommended for ease in the assembly of this product.
6. Keep all small parts of this product away from children. They may cause serious injury.
7. Have the following tools: Flat Head Screwdriver, #2 Phillips Head Screwdriver and Hammer.

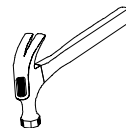
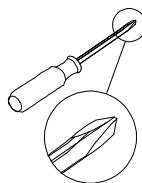
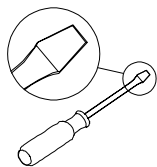

8. Note: Power tools should not be recommended to assemble this product. If using a power drill or power screwdriver for screwing, please be aware to slow down and stop when the screw is tight. Failure to do so may result in stripping the screw.

---

## HOW THE KNOCK DOWN (KD) ASSEMBLY SYSTEM WORKS

1. Screw the Cam Bolt into the pre-drilled hole on the panel. Make sure the Cam Bolt goes into the pre-drilled hole on the end of the panel for the Cam Lock.
2. Insert the Cam Lock into the pre-drilled large hole on the panel. Make sure the arrow on the face of the Cam Lock points towards the Cam Bolt.
3. Take a Phillips screwdriver and rotate the Cam Lock clockwise to lock the Cam Bolt.
4. Use the sticker to conceal the Cam.

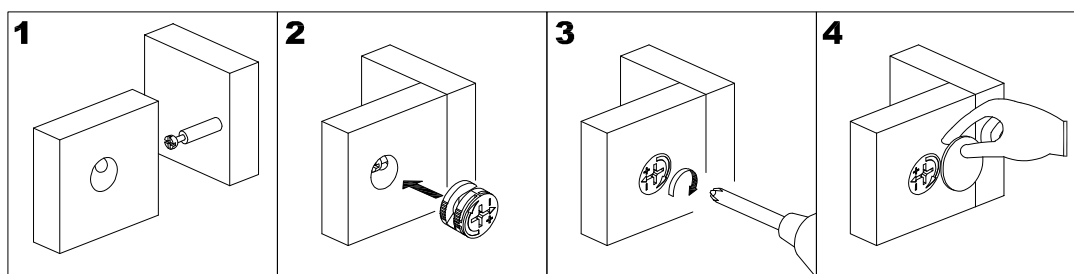

# How do I get the two doors to align flat by adjusting the hinges?

1

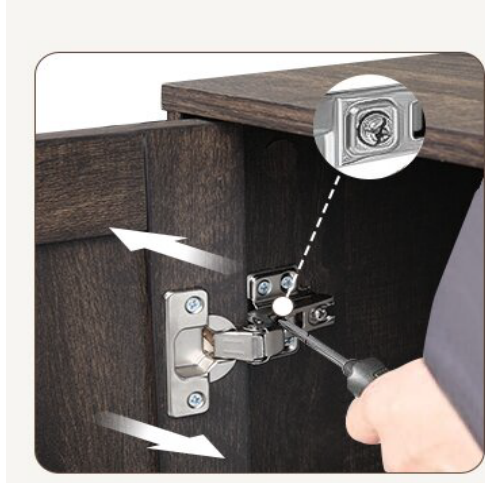
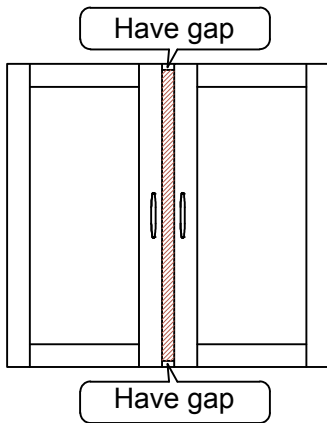

Turn the screw to the right can make the door approach inside.

2

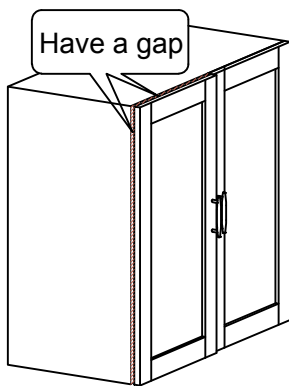

1. Rotate the screws to the left
2. Push the door to the cabinet
3. Rotate the screws to the right

Please take the following steps to adjust first.

3

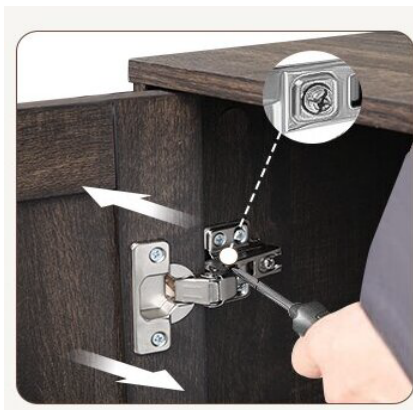
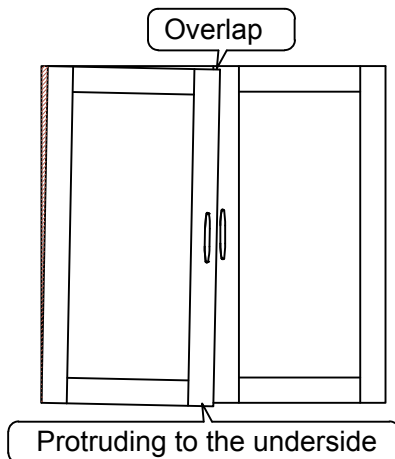

Turn the screw to the left can make the top of the door tilted outward.

4

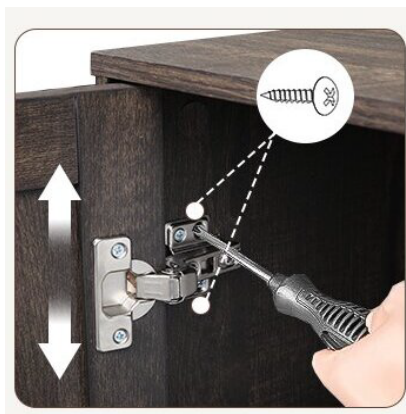
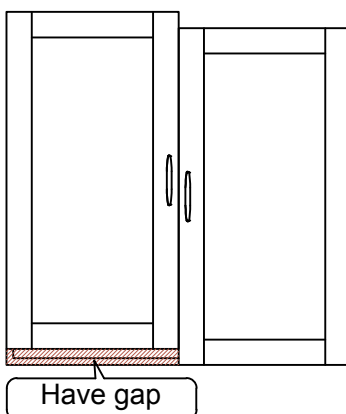





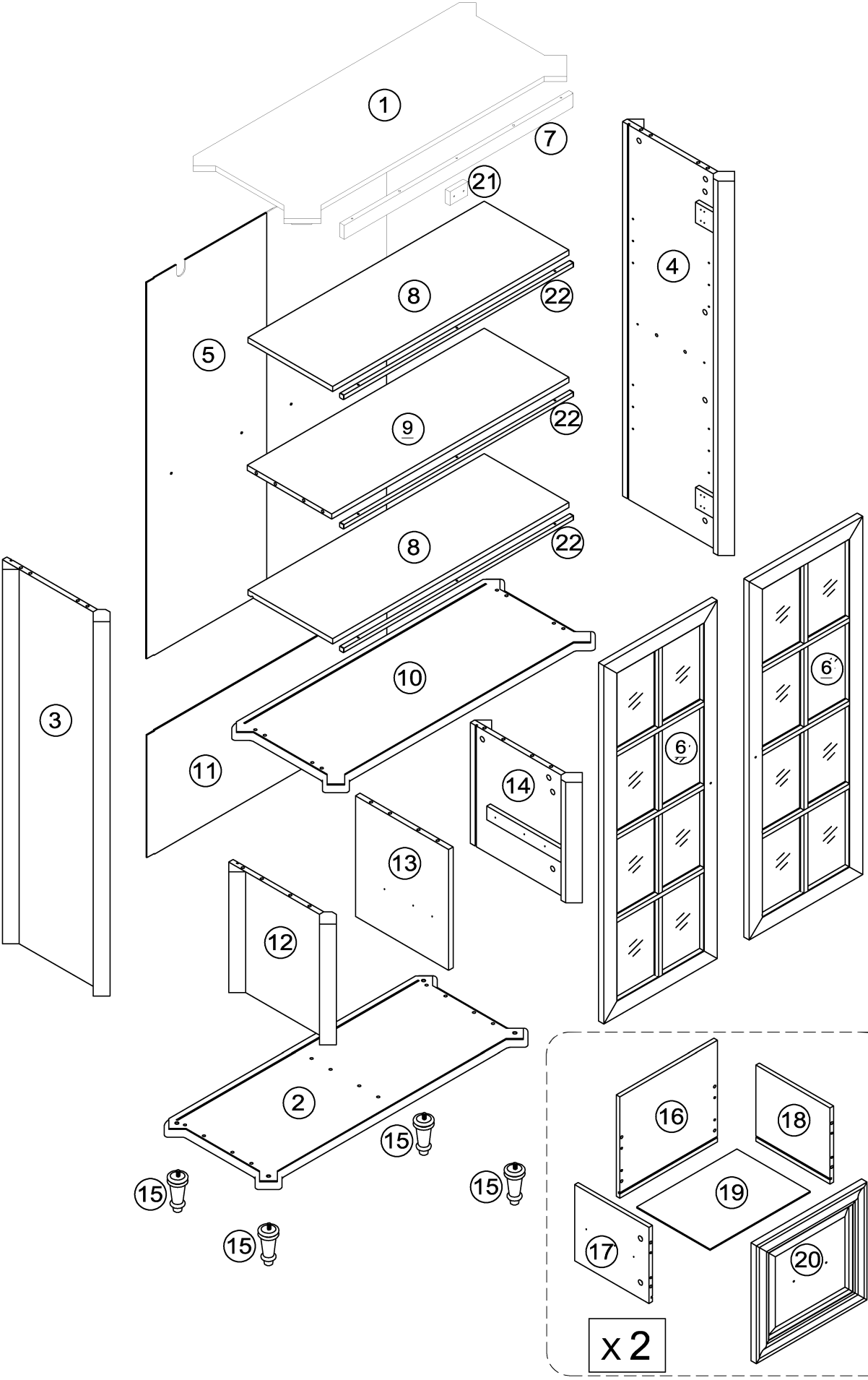



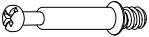



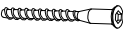

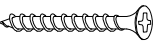



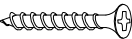

1. Turn the screw to the left
2. Lower the door's height so that 2 doors are of the same height
3. Turn the screw to the right

# PARTS LIST



# HARDWARE LIST

A		Ø6x35mm	Cam bolt	22 pcs
B		Ø15x9mm	Small cam lock	22 pcs
C		Ø20mm	Cam cover	22 pcs
D		Ø6x30mm	Small wooden dowel	16 pcs
E		Ø6x50mm	Screw	10 pcs
F		Ø4x16mm	Handle bolt	4 pcs
G		Ø4x38mm	Screw	11 pcs
H			Knob	2 pcs
I		Ø3.5x12mm	Screw	24 pcs
J		Ø4x25mm	Knob bolt	2 pcs
K			Plastic wedge	20 pcs
L		Ø3x17mm	Flat-head screw	20 pcs
M			Shelf support	8 pcs
N			Handle	2 pcs
O		Ø35mm	Europe Hinge	4 pcs
P		Ø4x25mm	Screw	2 pcs
Q		Ø4	Hex key	1 pc
R		10"	Drawer slider	2 set
S			Tipping restraint	2 set
T		Ø3.5x15mm	Screw	4 pcs
U		Ø6x22mm	Bolt	9 pcs
V			Door stopper	1 pc

# HARDWARE LIST

W		Ø8x30mm	Large wooden dowel	26 pcs
X		Ø3.5x14mm	Hinge screw	25 pcs
Y			Glue tube	1 pc

# STEP 1

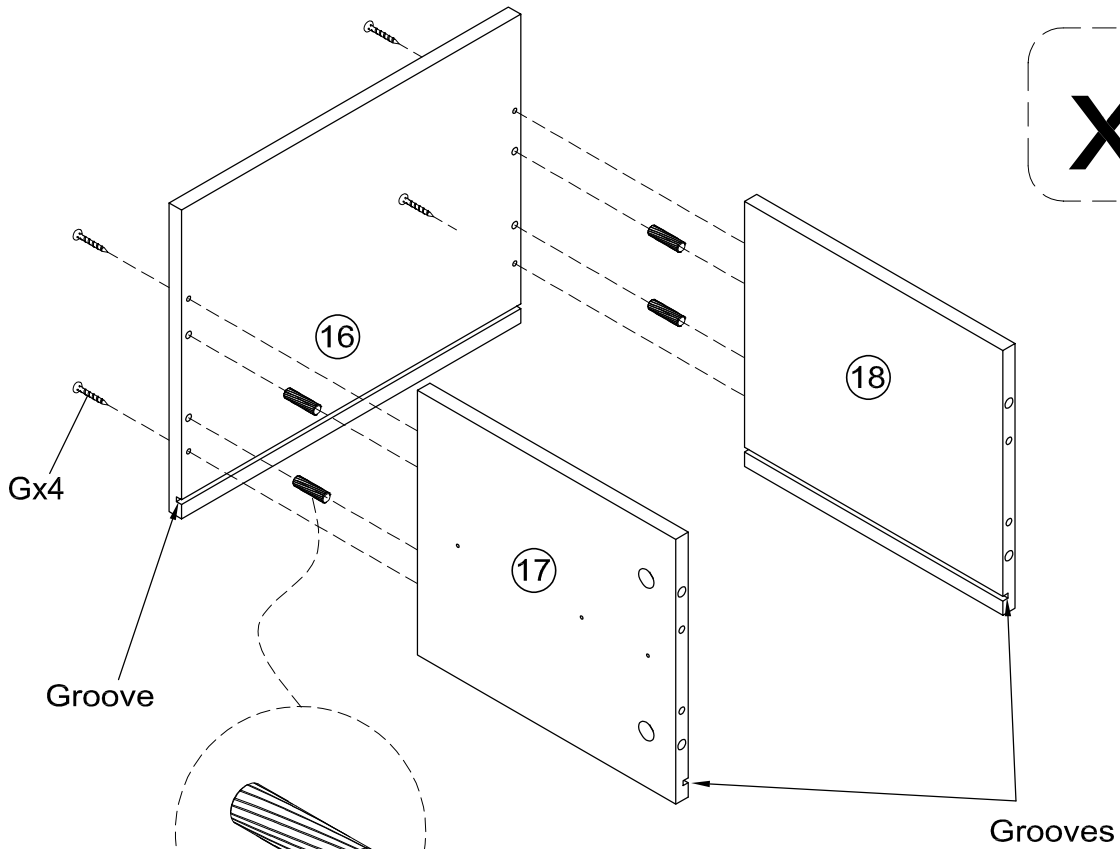
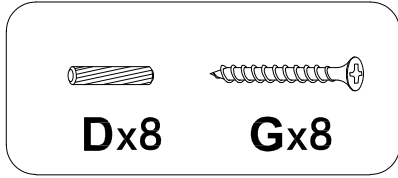

**x2**

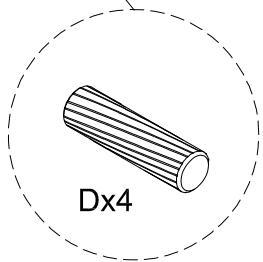

Small wooden dowel

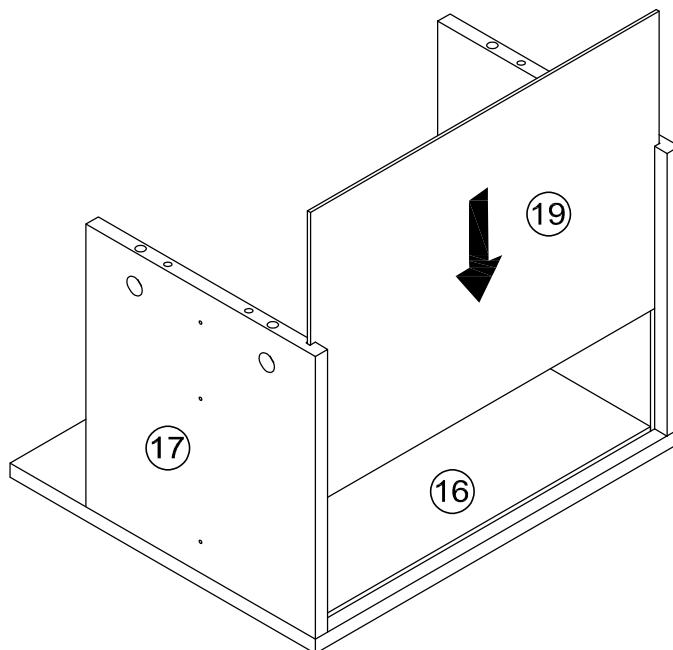
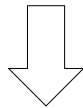

**x2**

# STEP 2

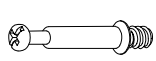

Ax8



Bx8



Dx8



Fx4



Nx2

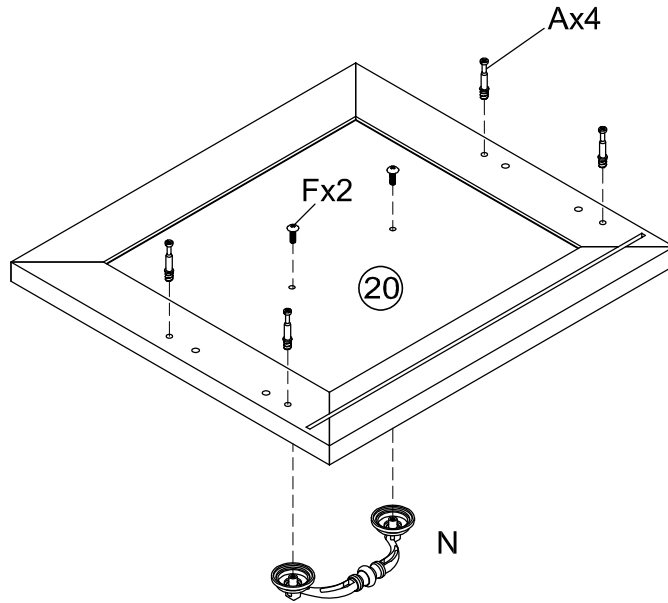
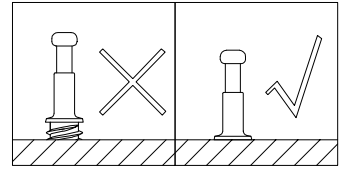
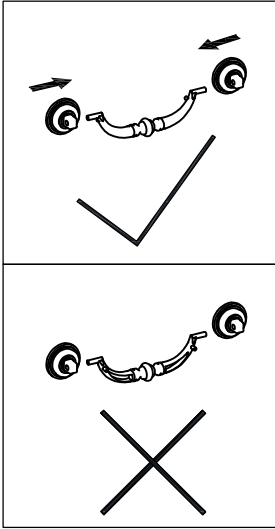

x2

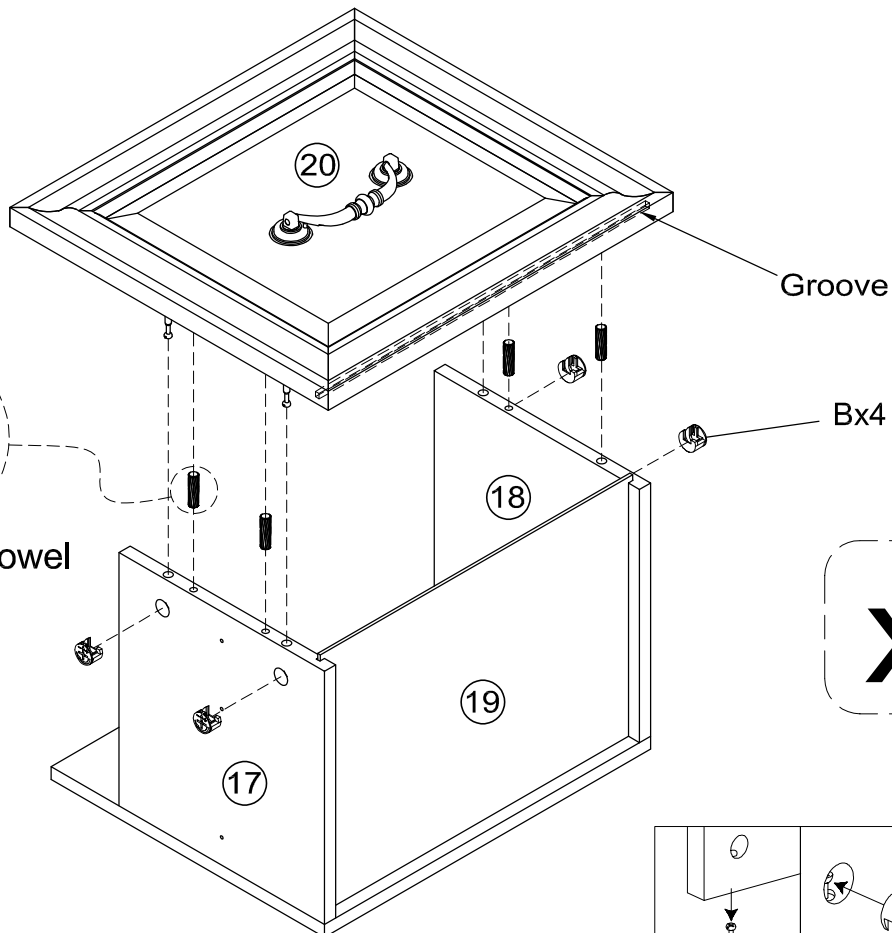

x2

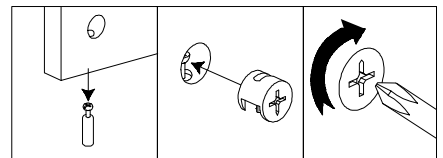

# STEP 3

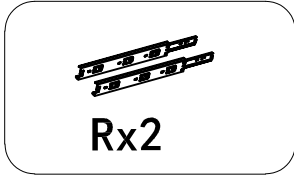

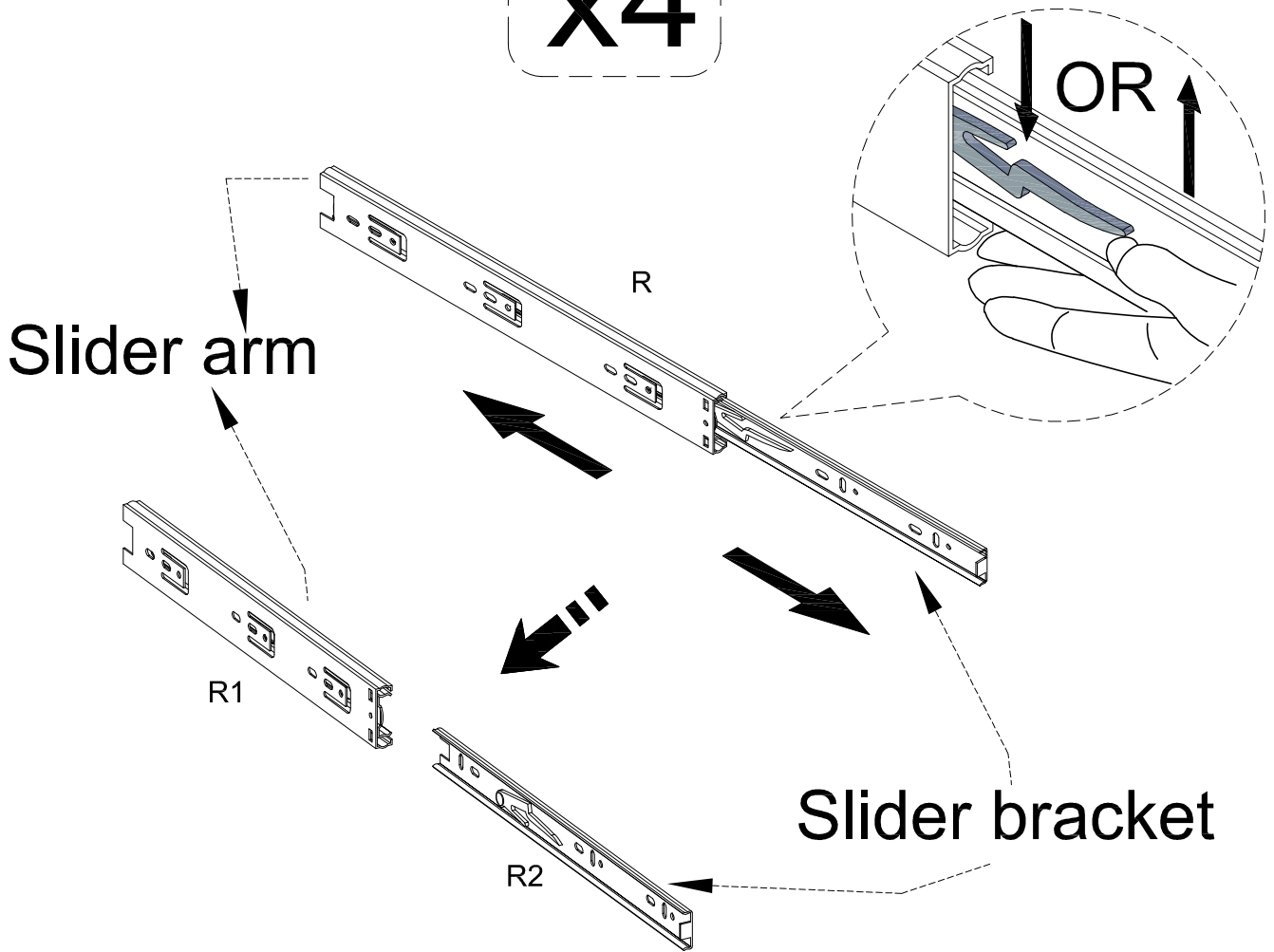

x4



Sperate the side runners by extending the slide runner all the way forward. Press the plastic release lever of the ball bearing slides up pull the slide runner complete out.

# STEP 4

 **1x12**       **R2x4**

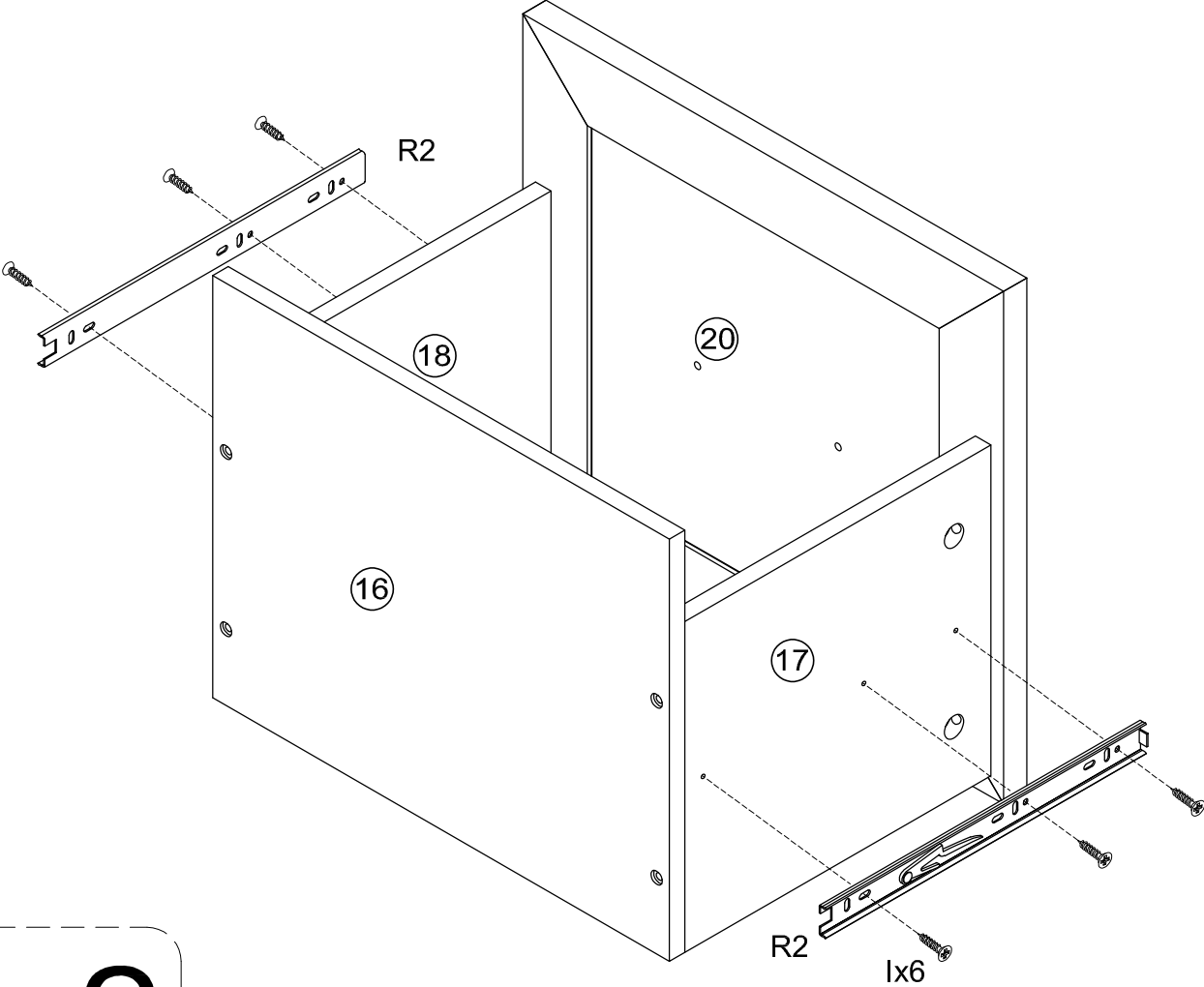

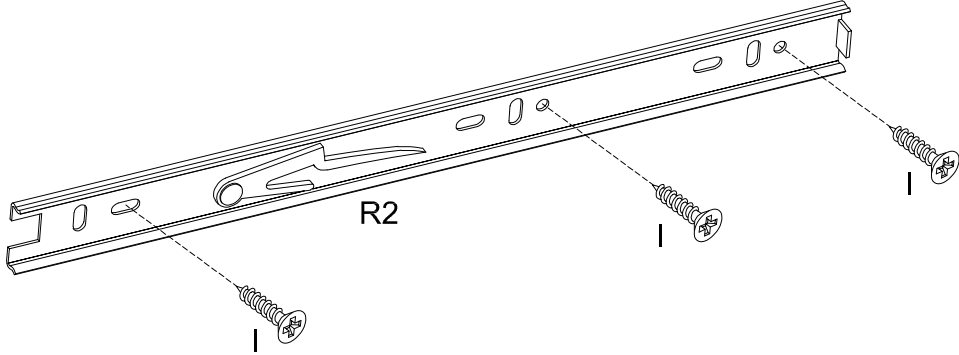

**x2**

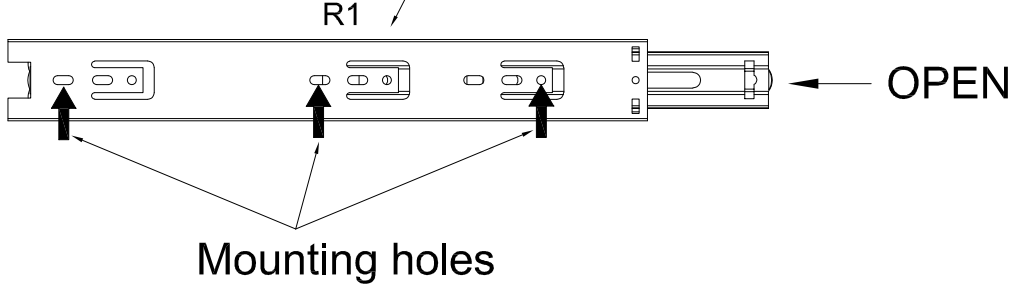
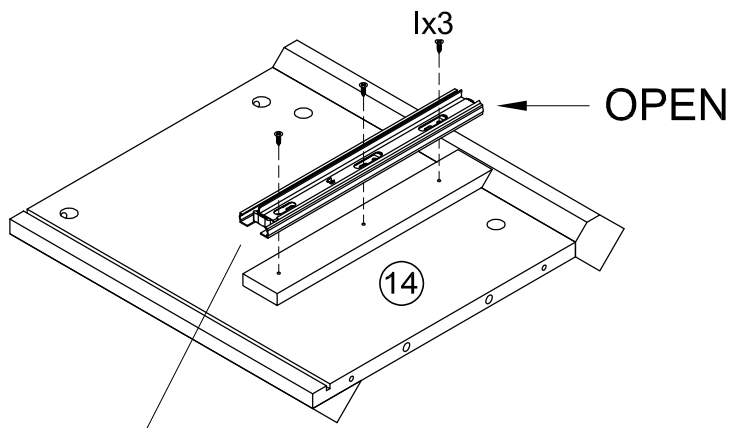
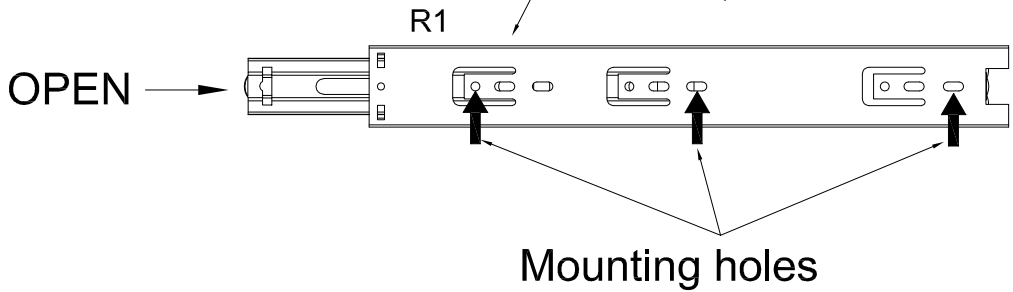
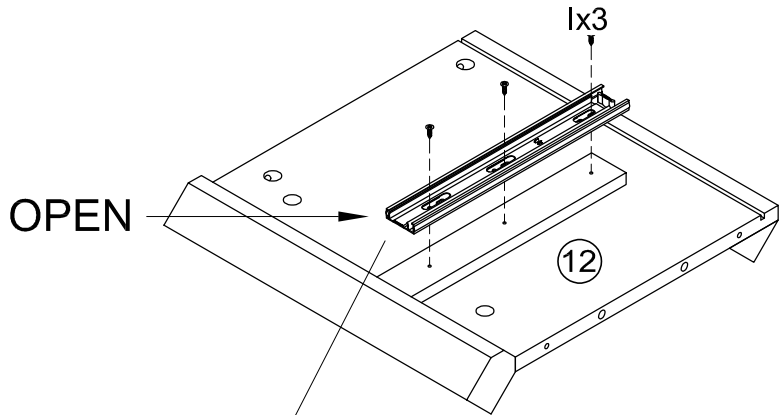
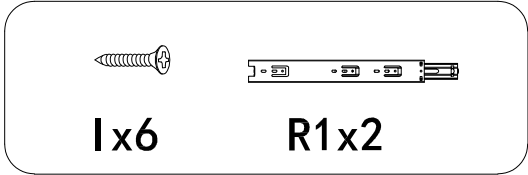

# STEP 5



# STEP 6

 **1x6**       **R1x2**

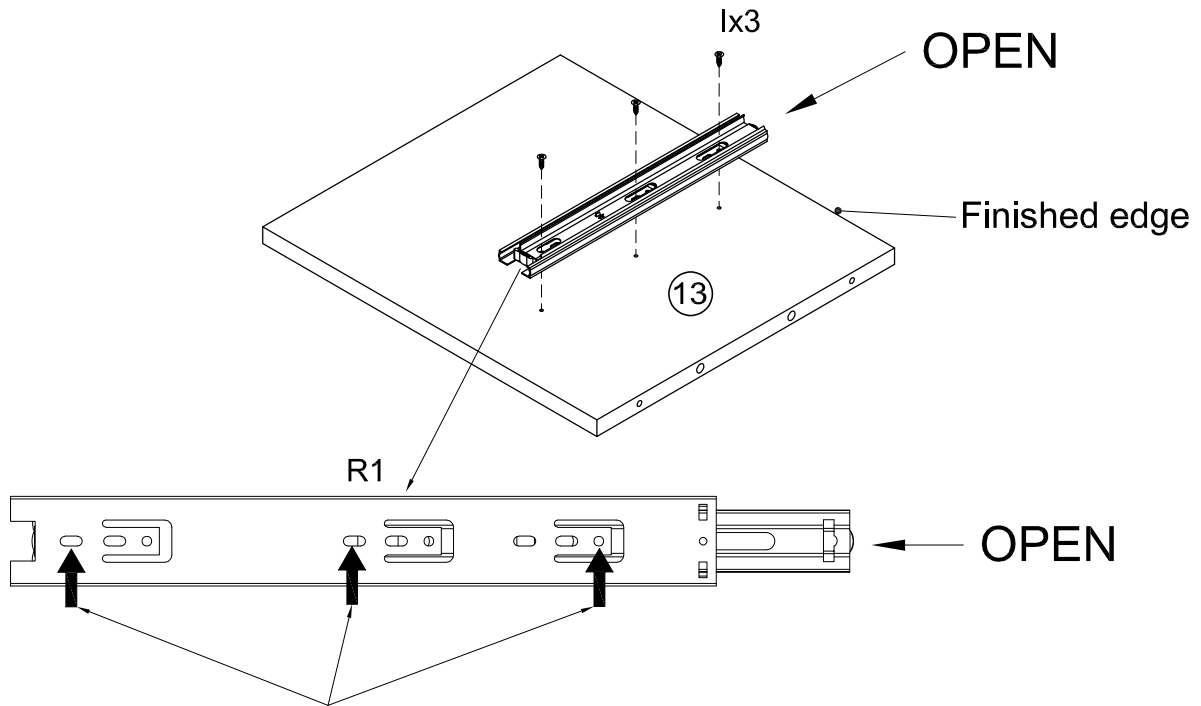

Mounting holes

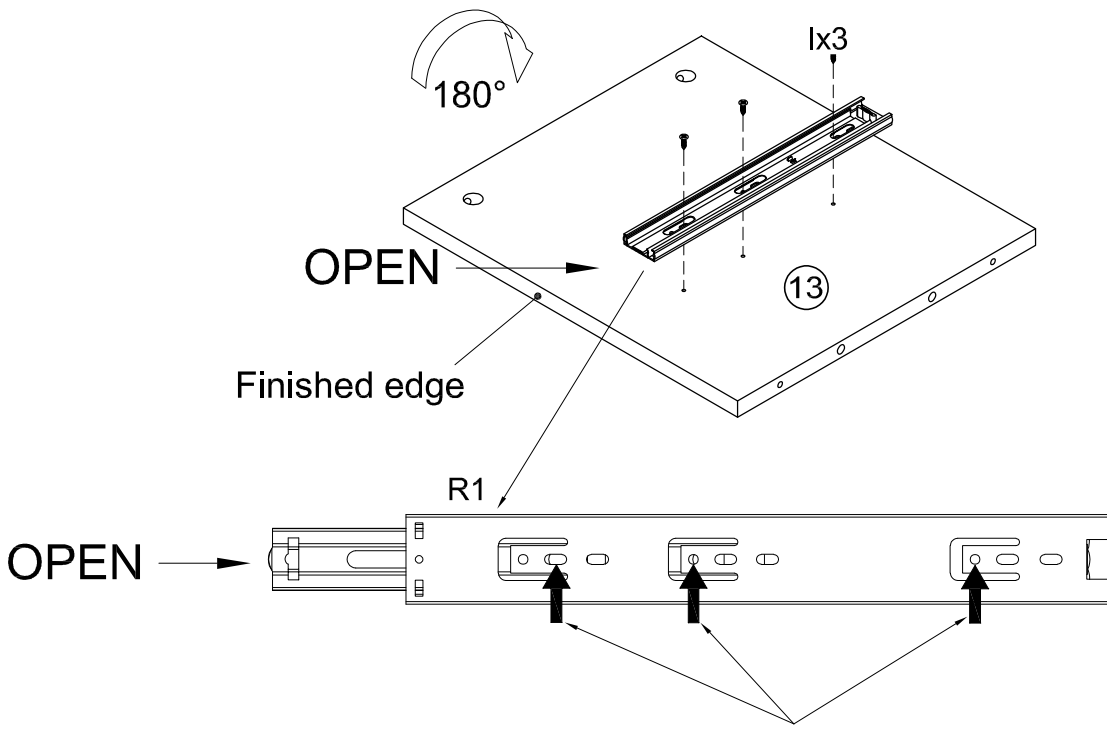

Mounting holes

# STEP 7

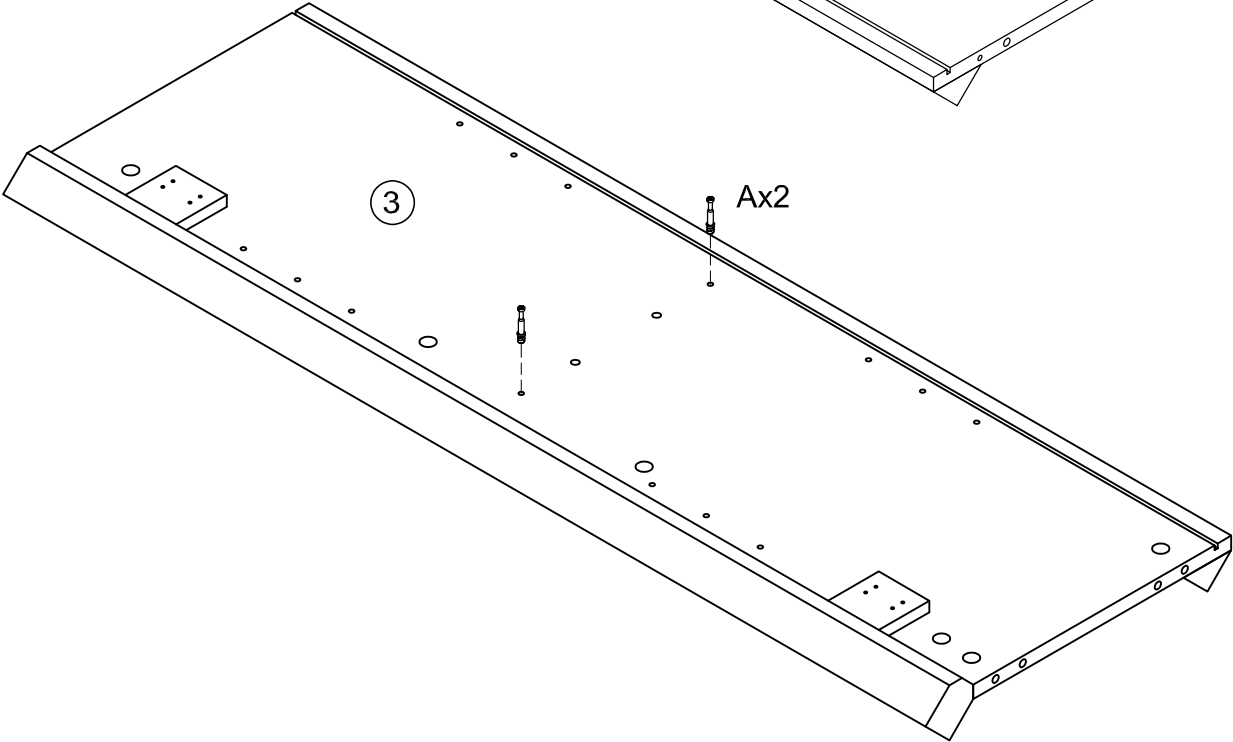
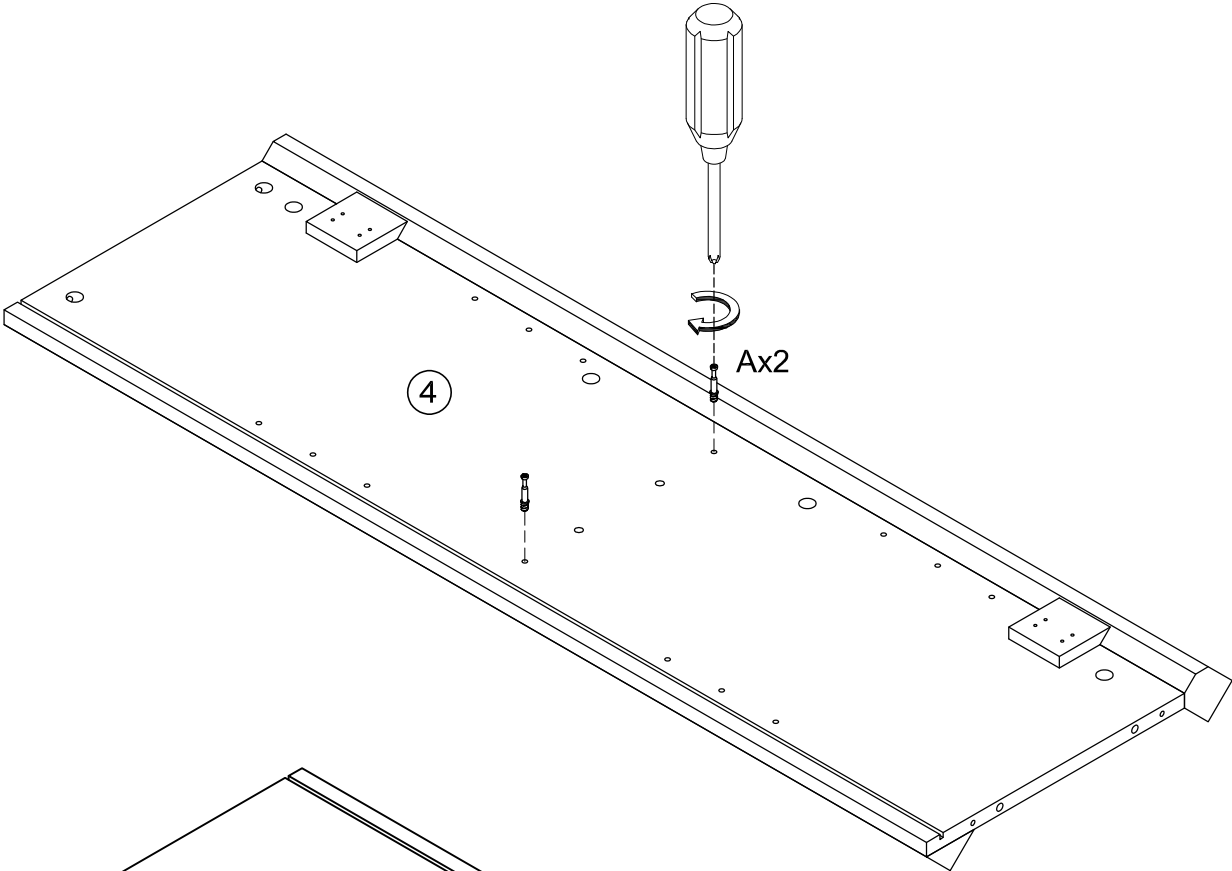
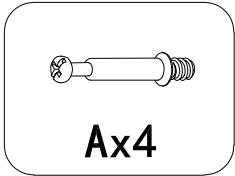

# STEP 8

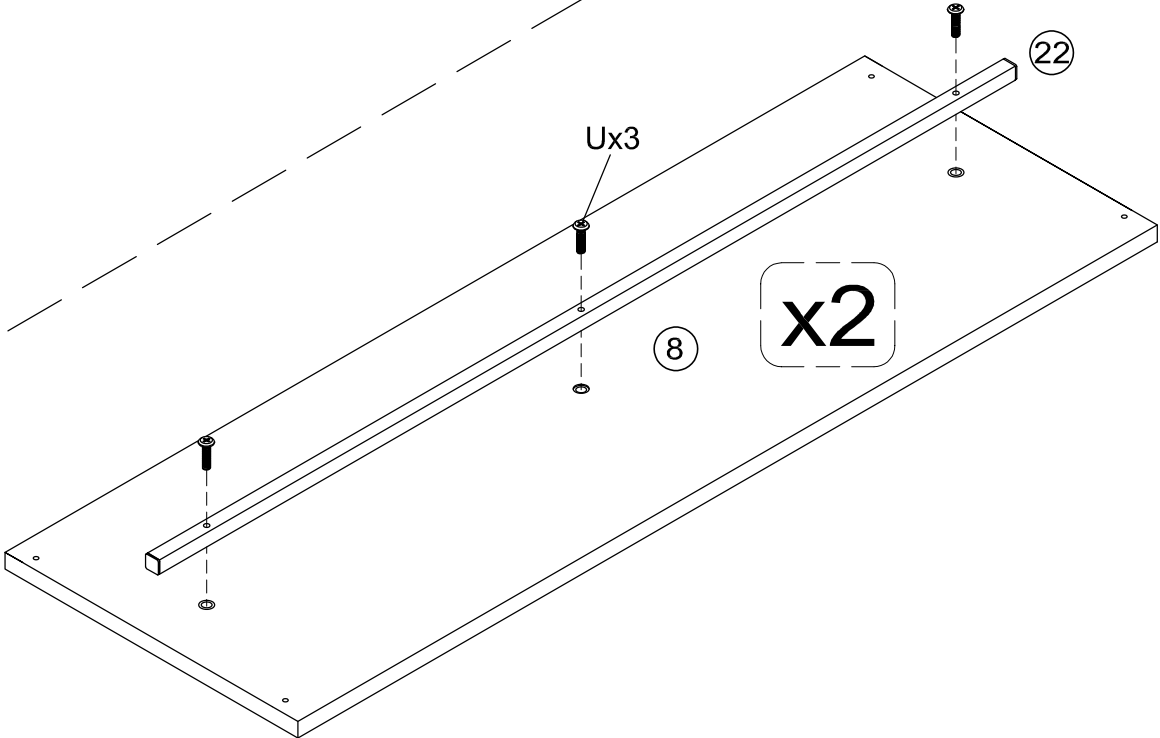
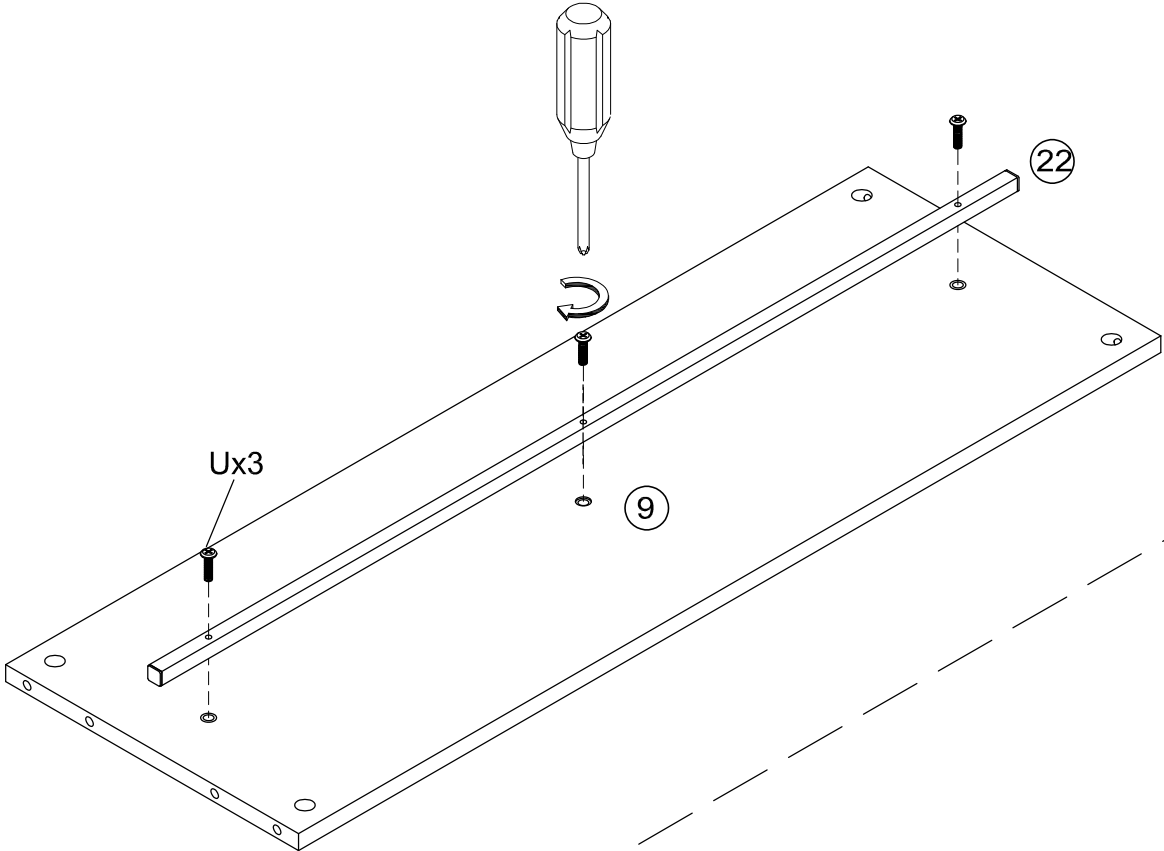
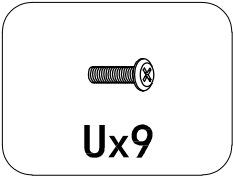

# STEP 9



Bx4



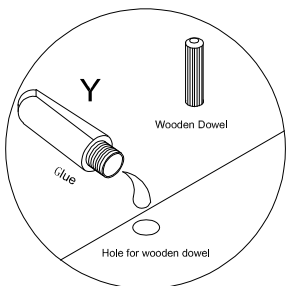
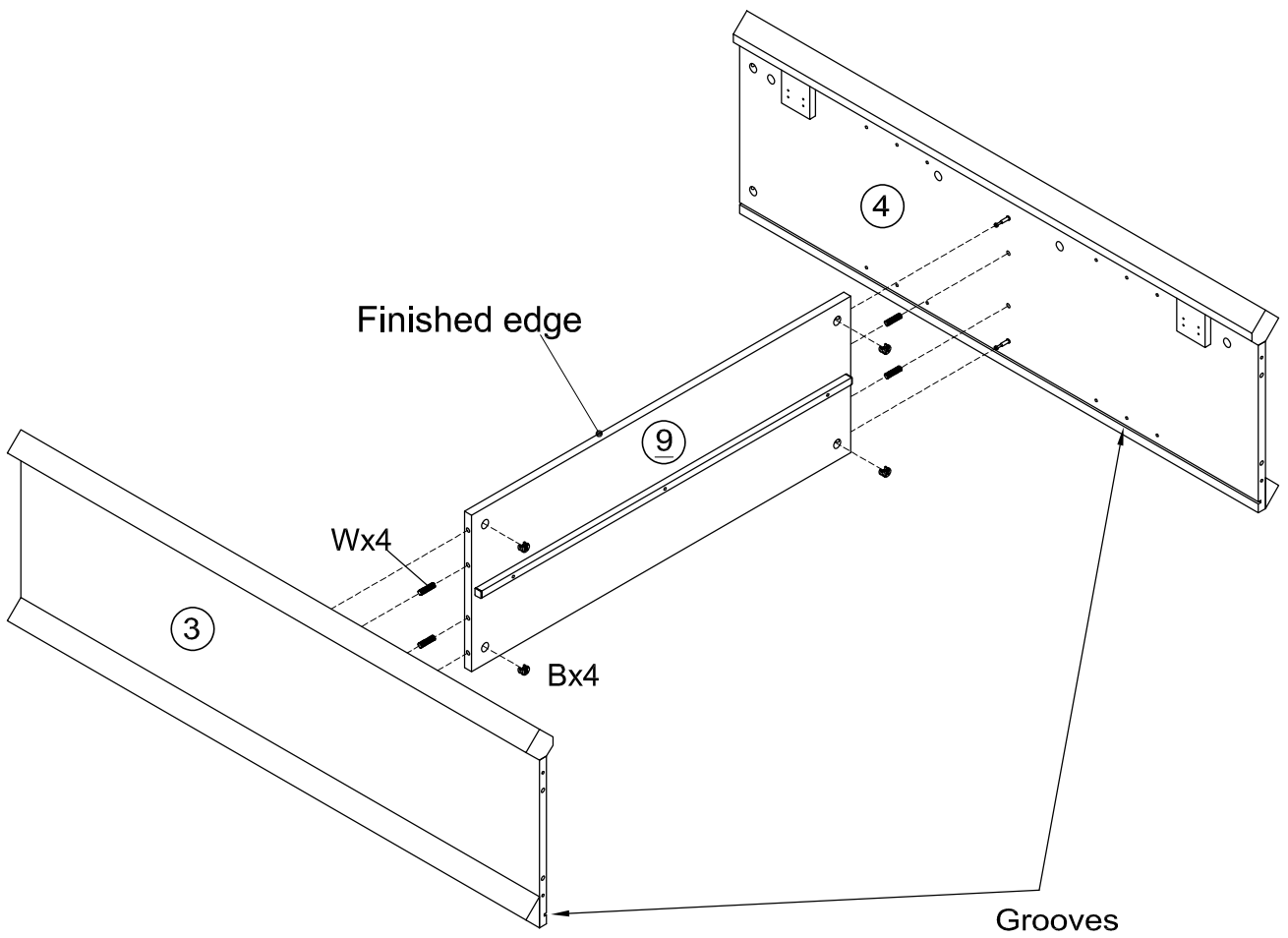
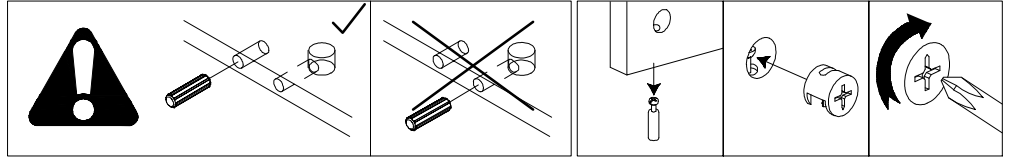

Wx4

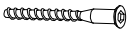

Use one drop of glue in dowel hole.

# STEP 10

		
<b>Wx4</b>	<b>Ex4</b>	<b>Q</b>

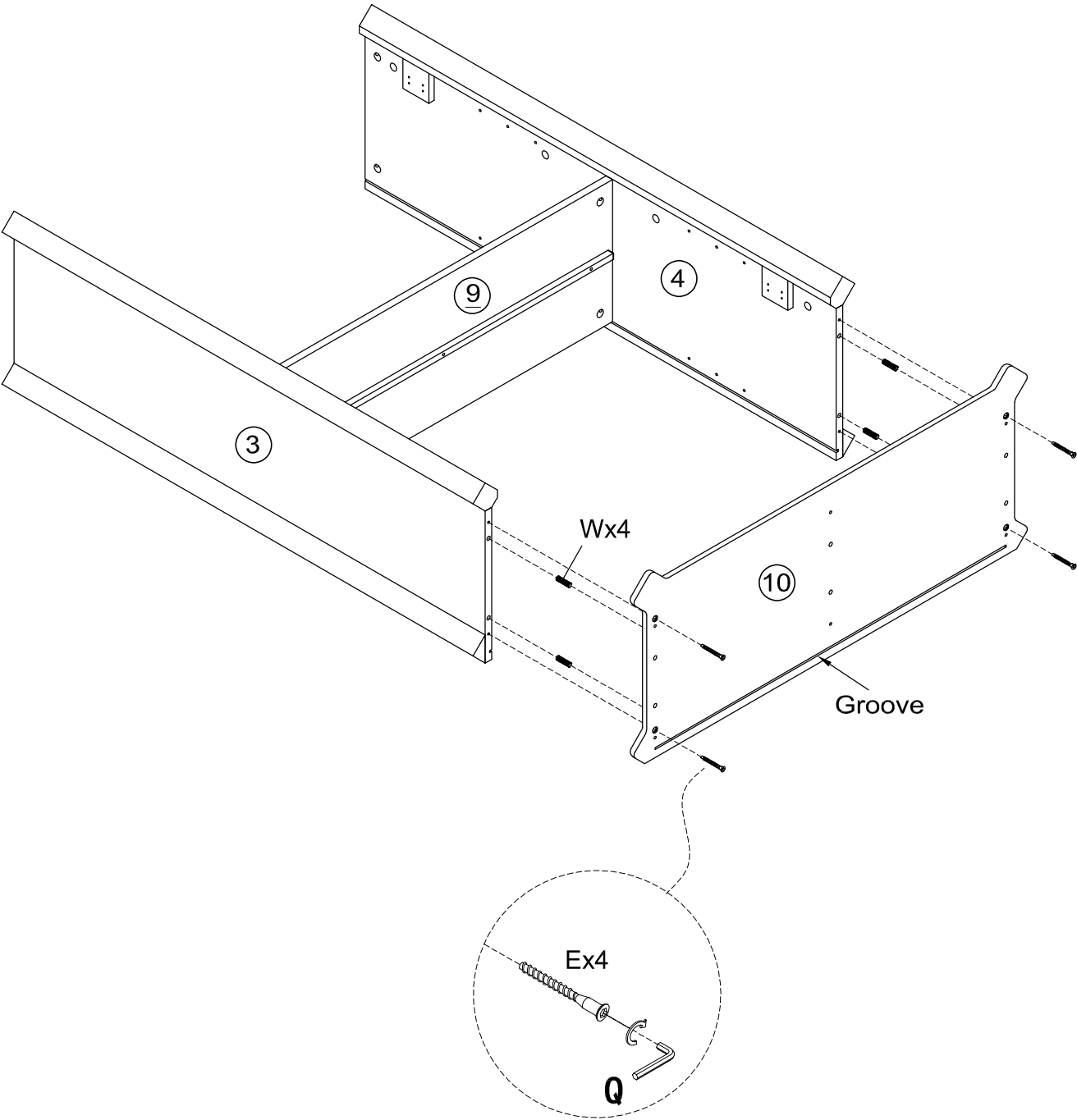

# STEP 11

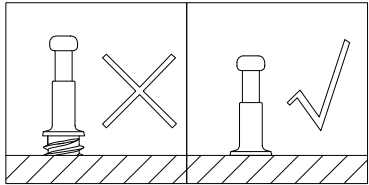
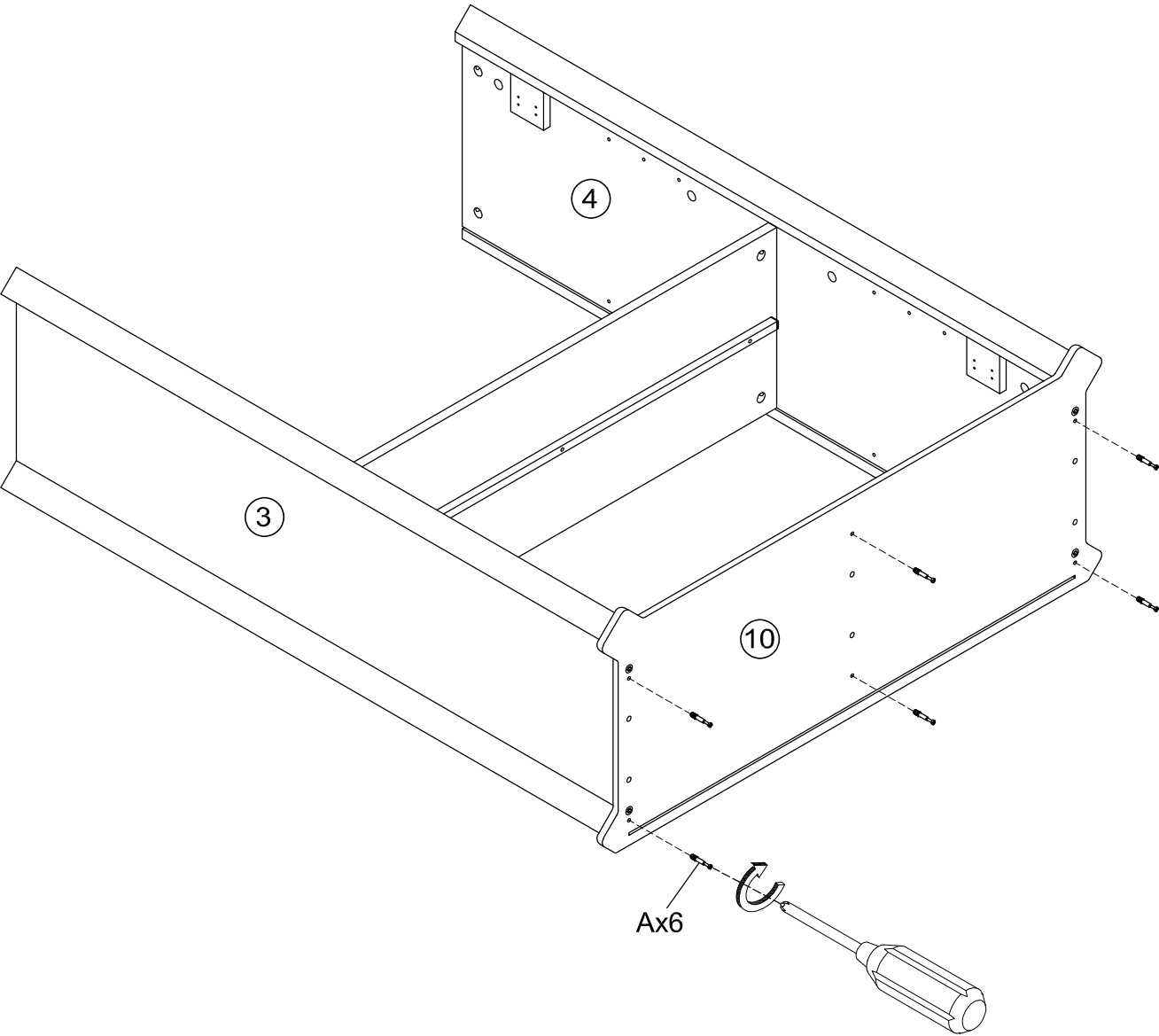
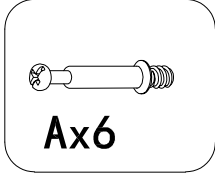

# STEP 12

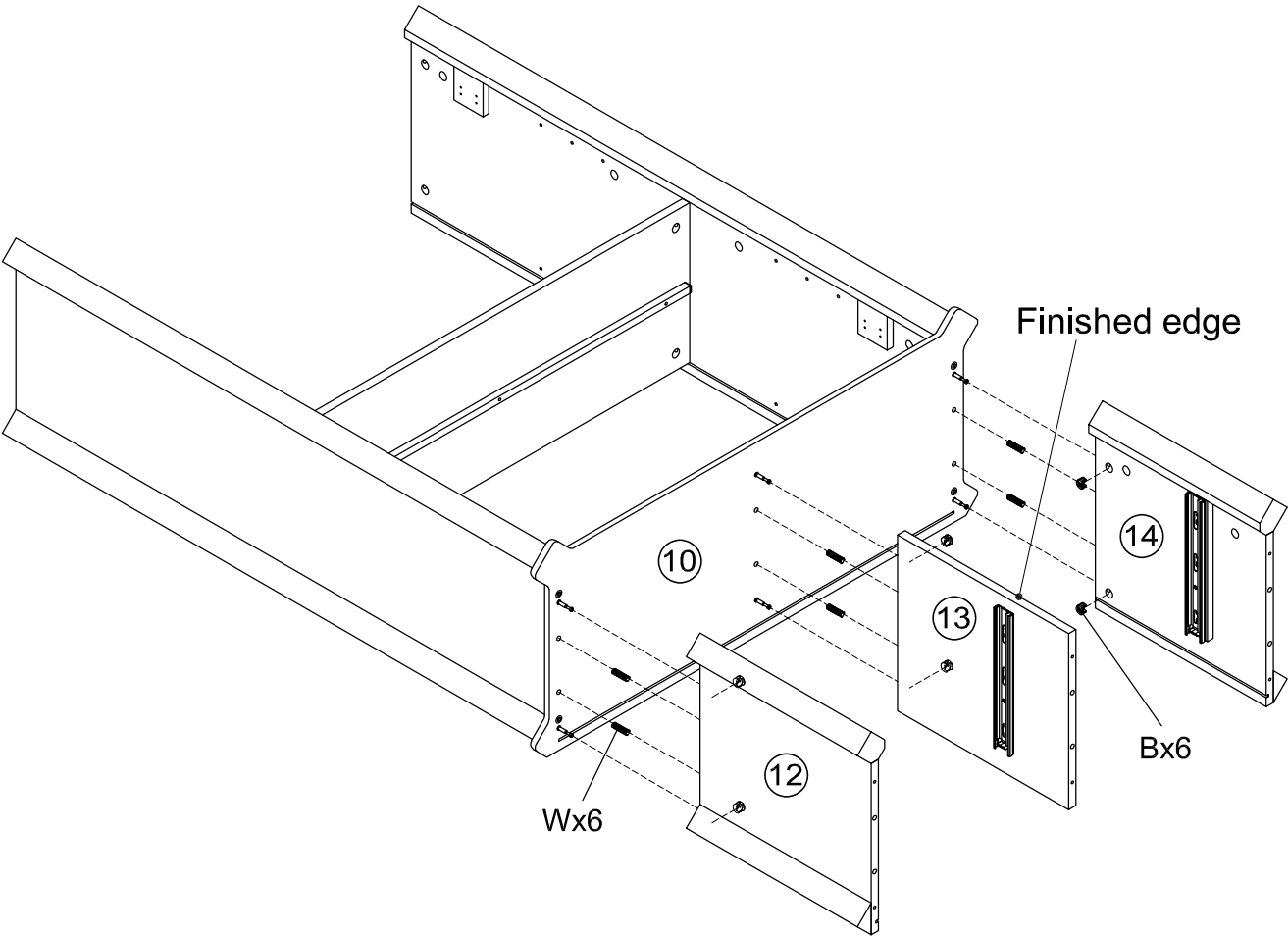
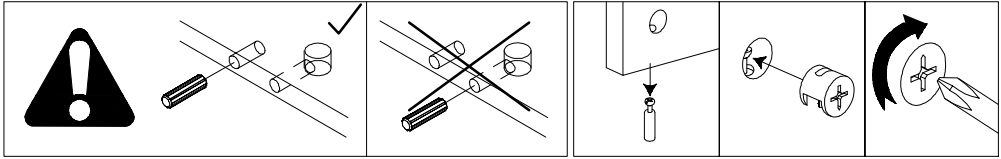
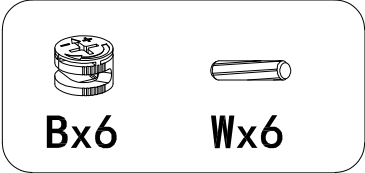

# STEP 13

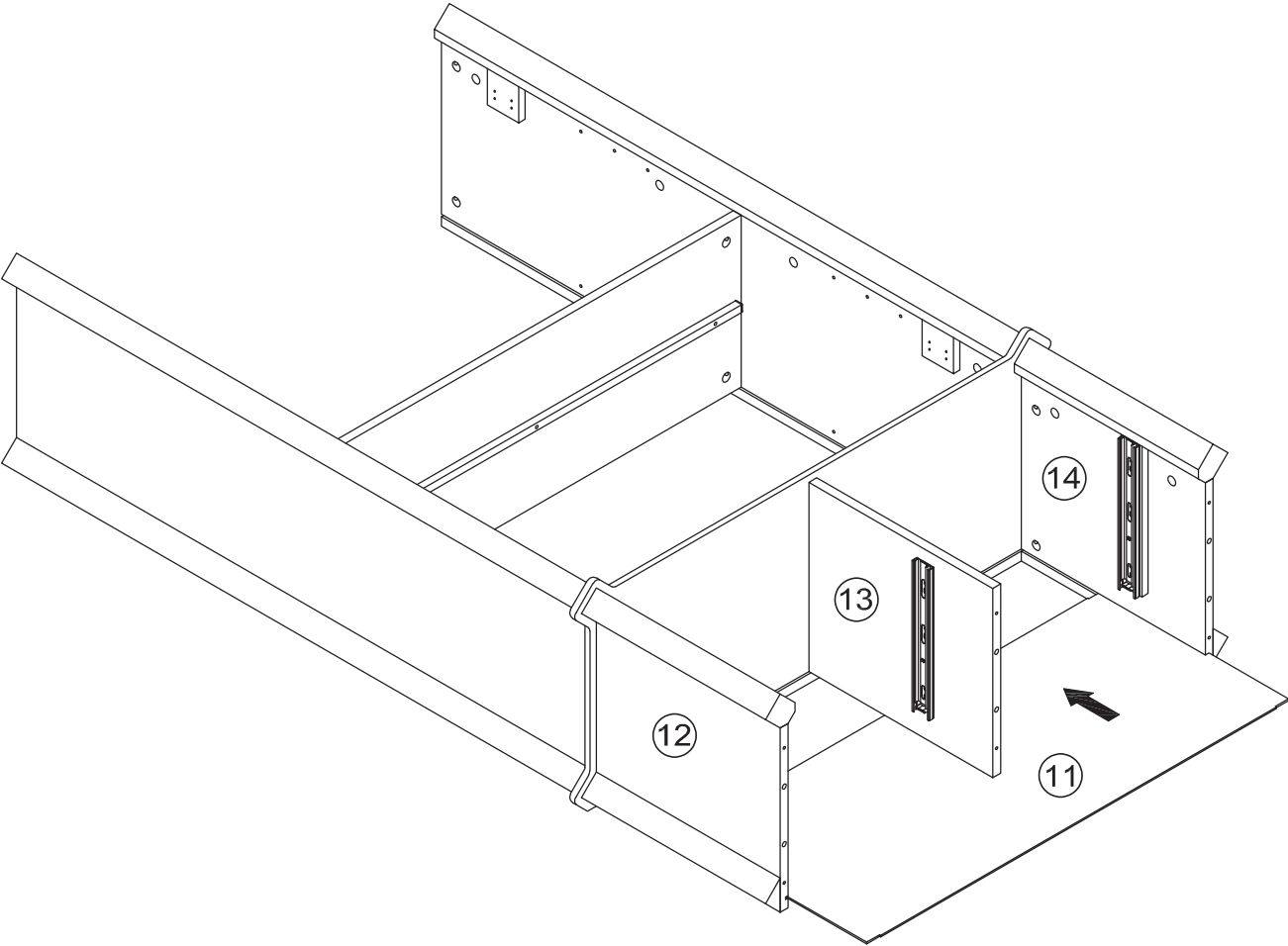

# STEP 14

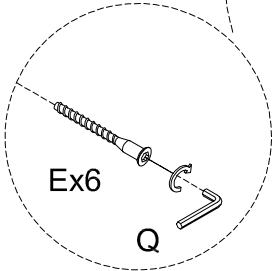
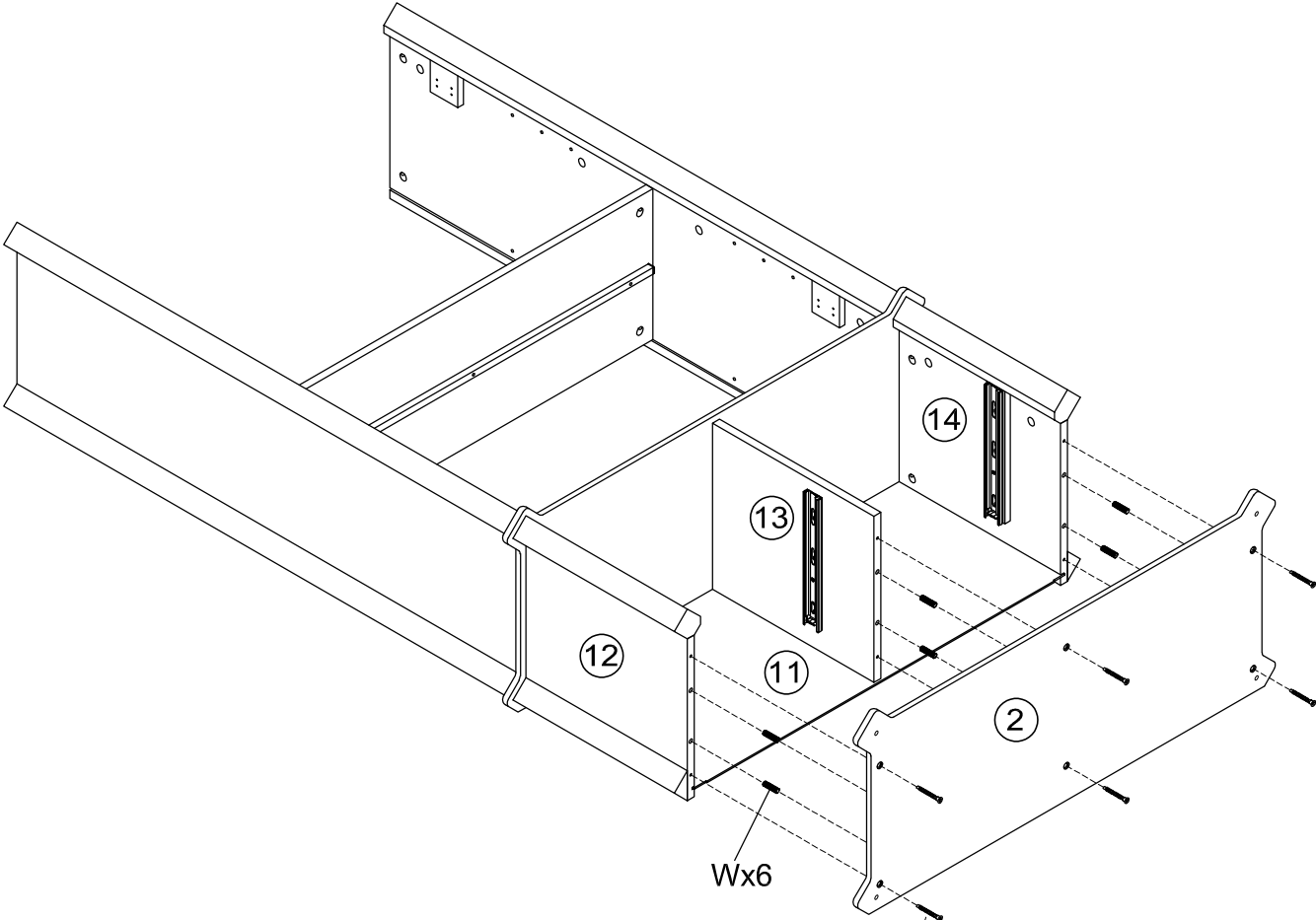
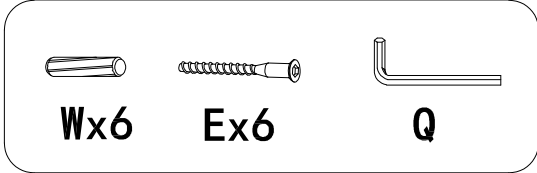

# STEP 15

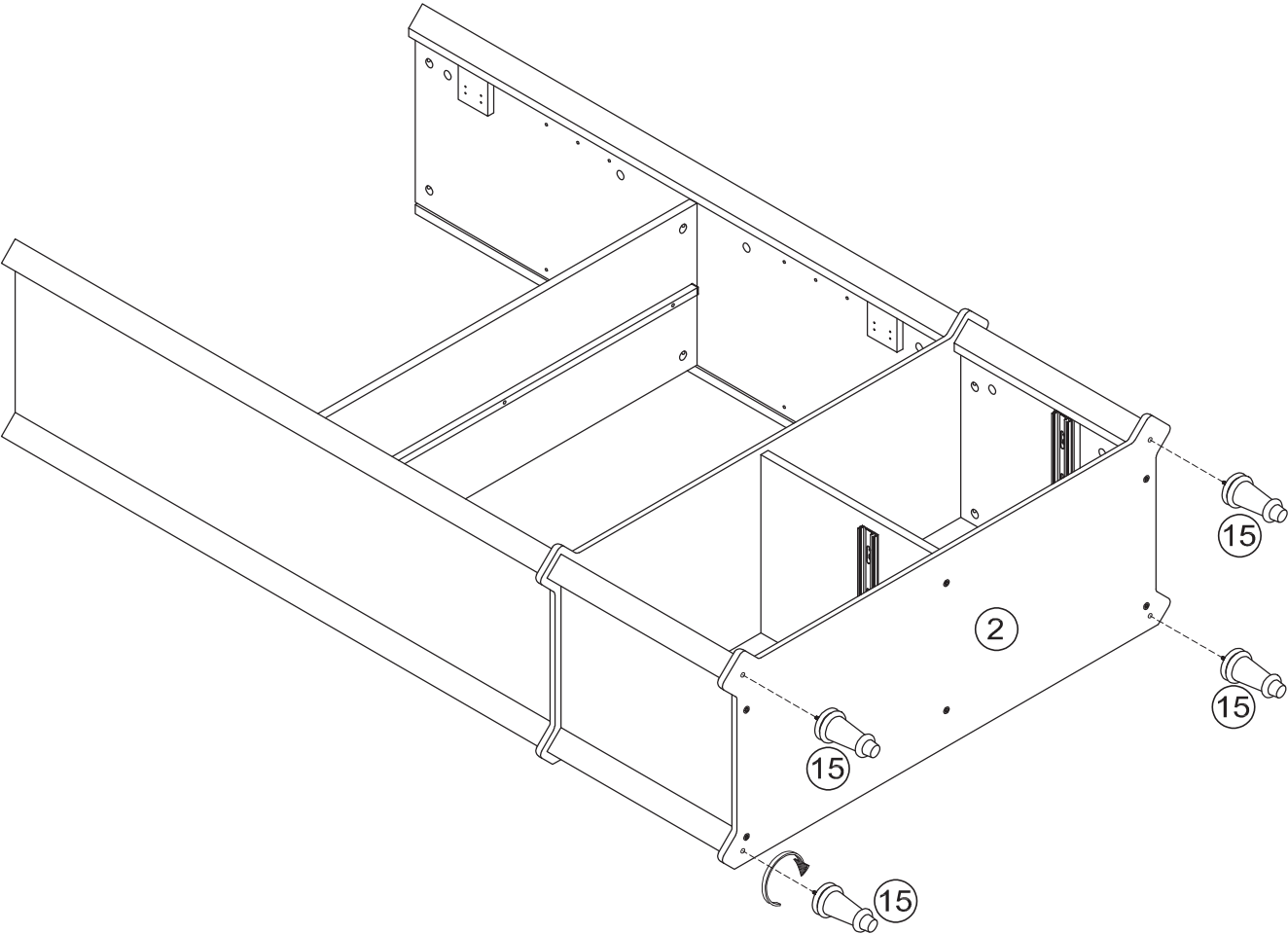

# STEP 16

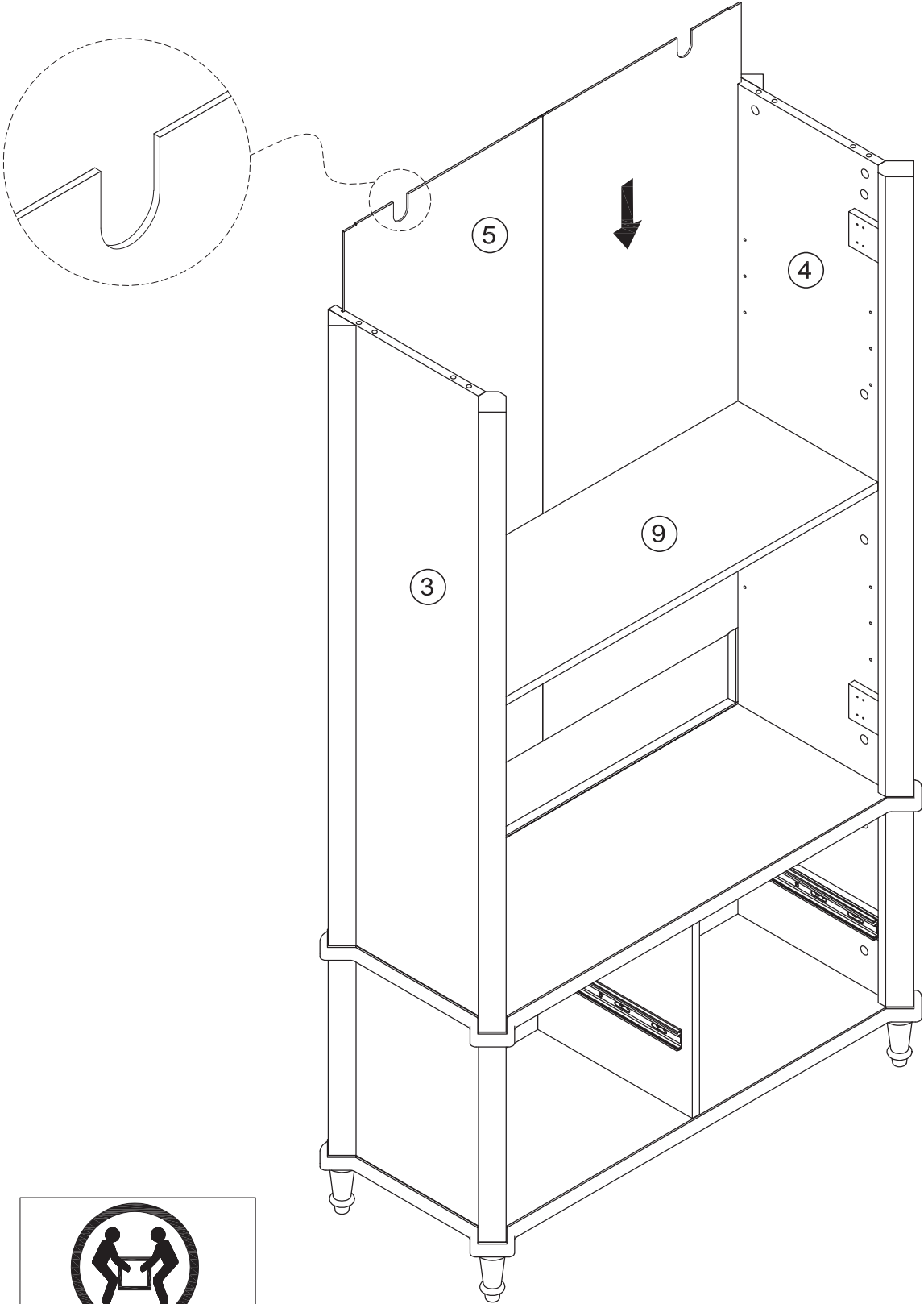

Note that this step requires 2 people to lift, and the process cannot be tilted under force, otherwise it will be damaged.

# STEP 17

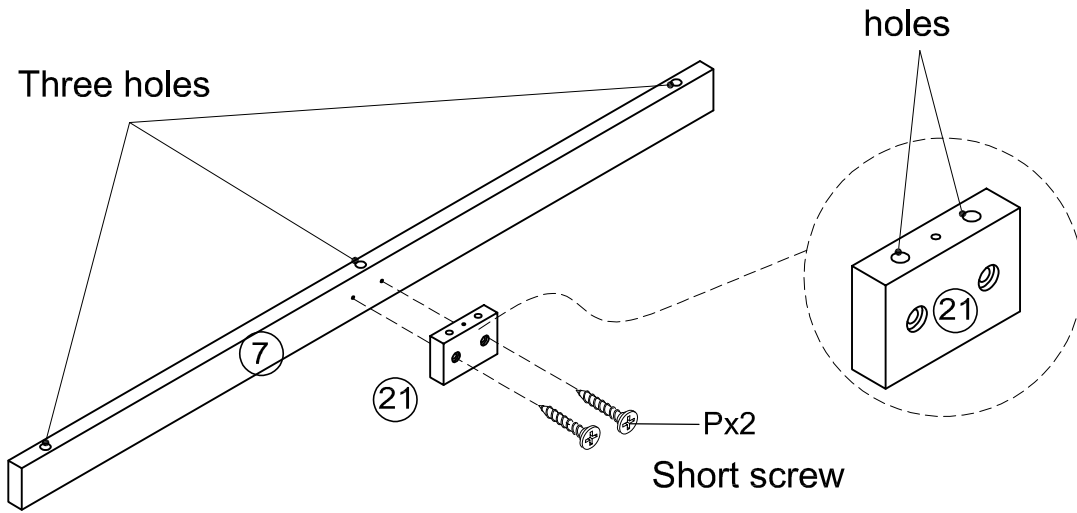
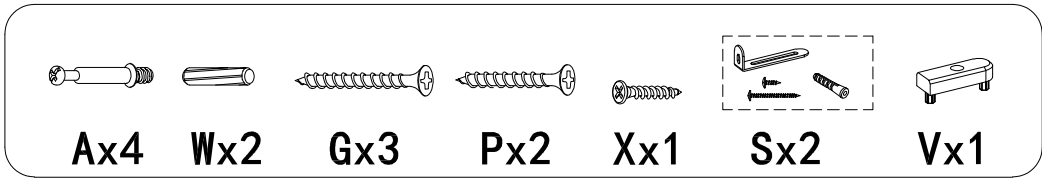

Note these holes' direction.

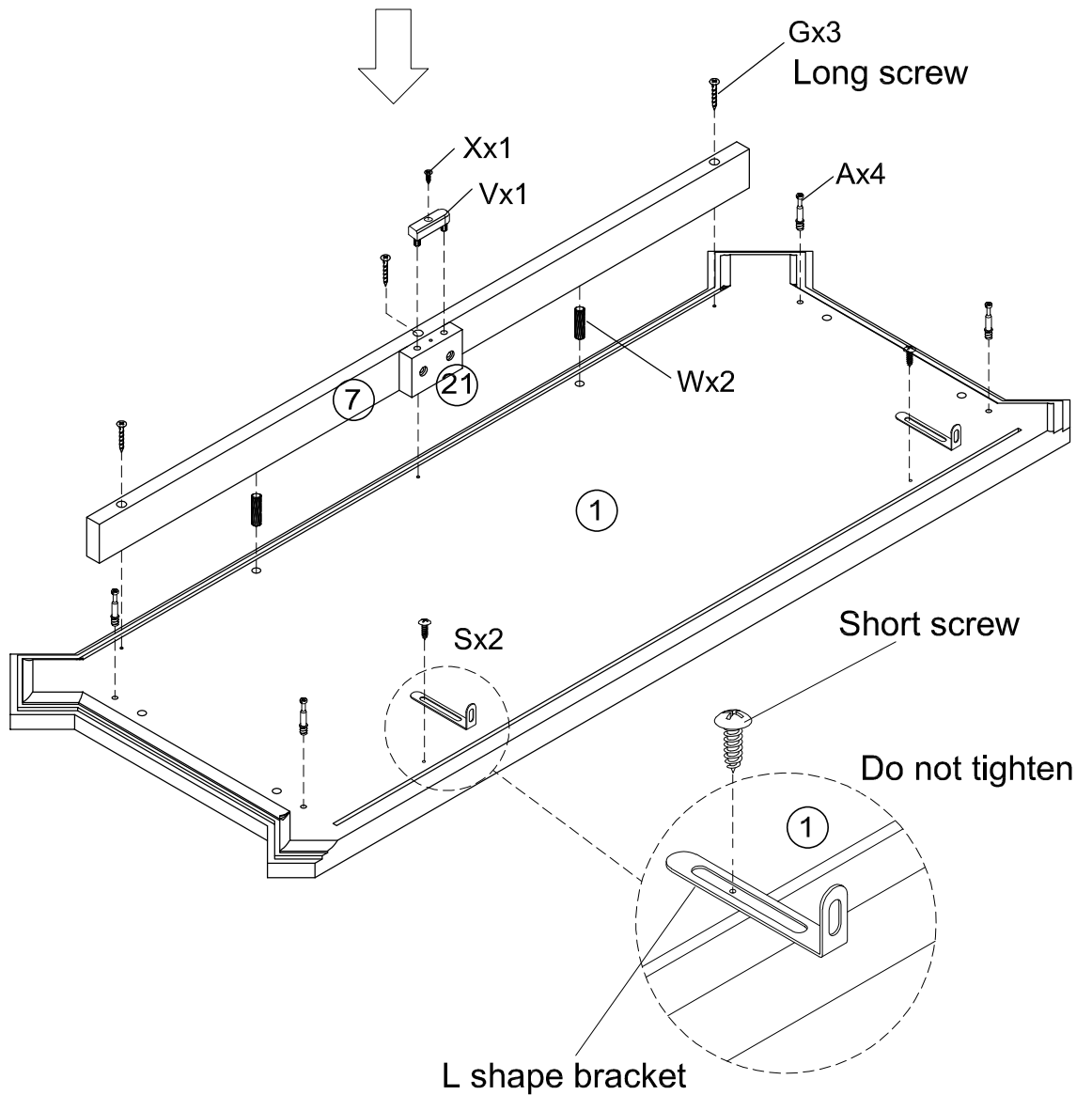

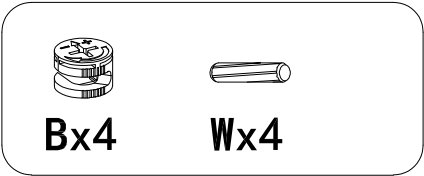

# STEP 18

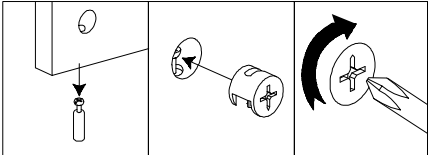
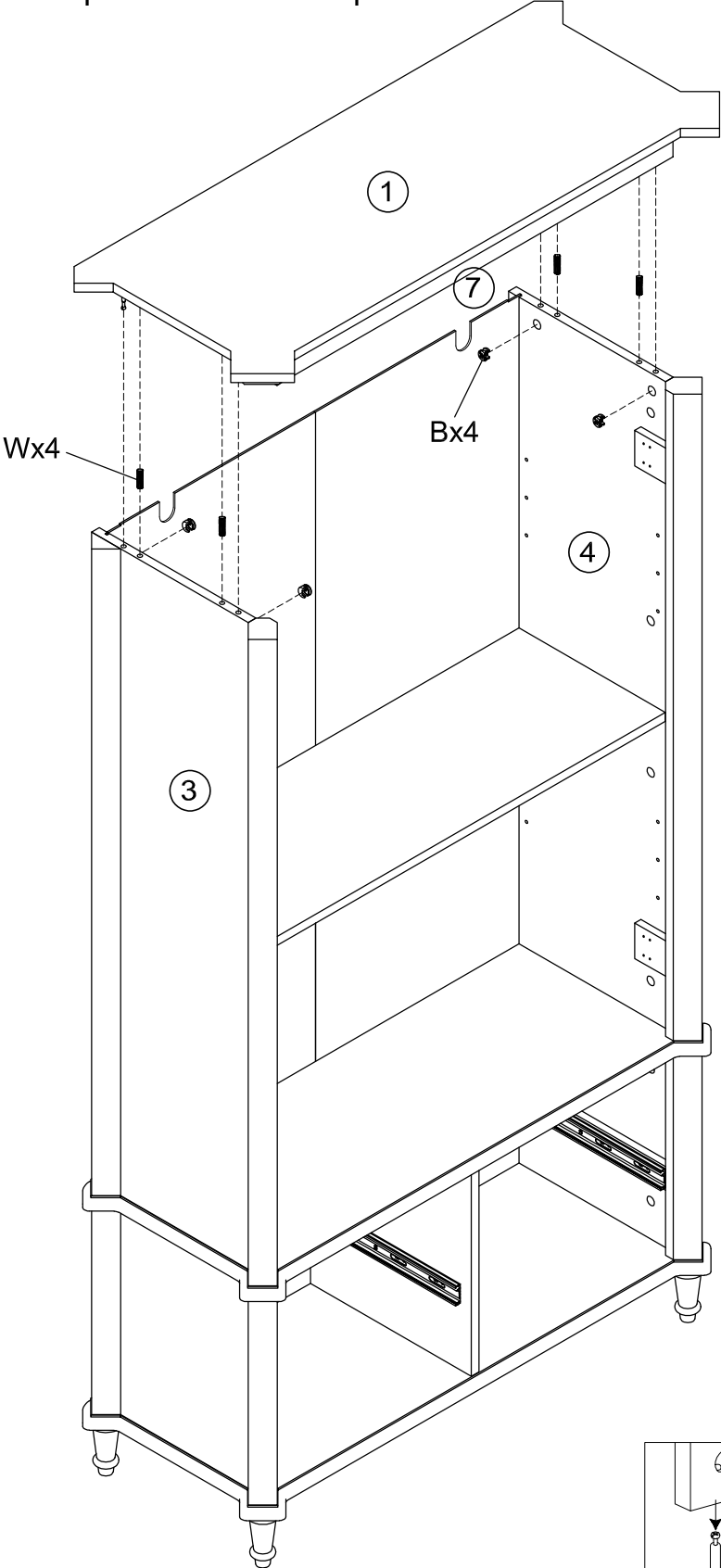

An assistance is required with this step.



# STEP 19

 **Kx20**       **Lx20**       **Tx4**

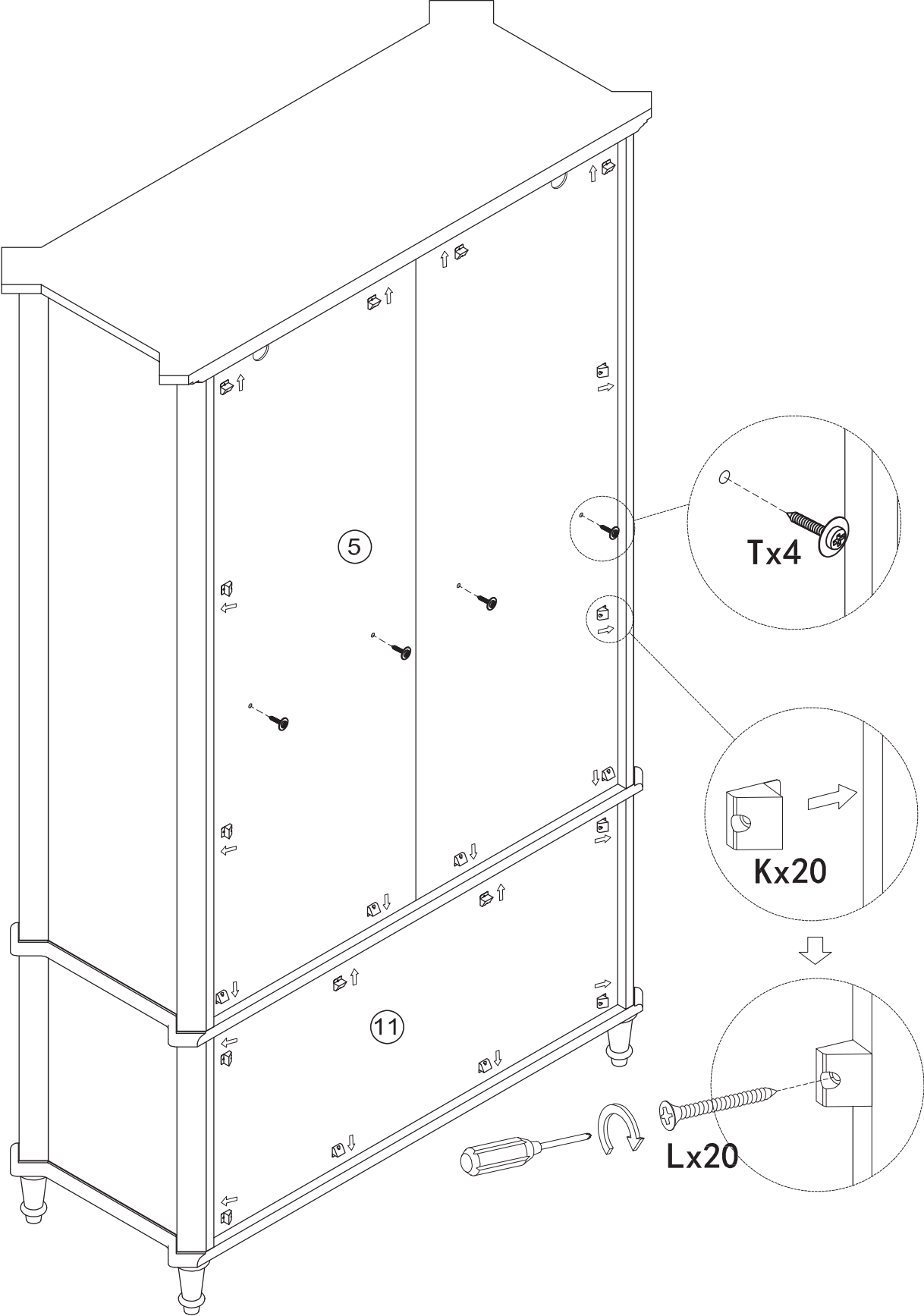

**Tx4**

**Kx20**

**Lx20**

# STEP 20

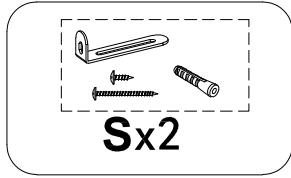

Serious or fatal injuries can occur from furniture tipping over. To prevent the furniture from tipping over, we recommend that it is permanently fixed to the wall. Wall anchor and hardware are included with this product. Please make sure hardware is suitable for your walls before installing, as different wall materials may require different types of anchors.

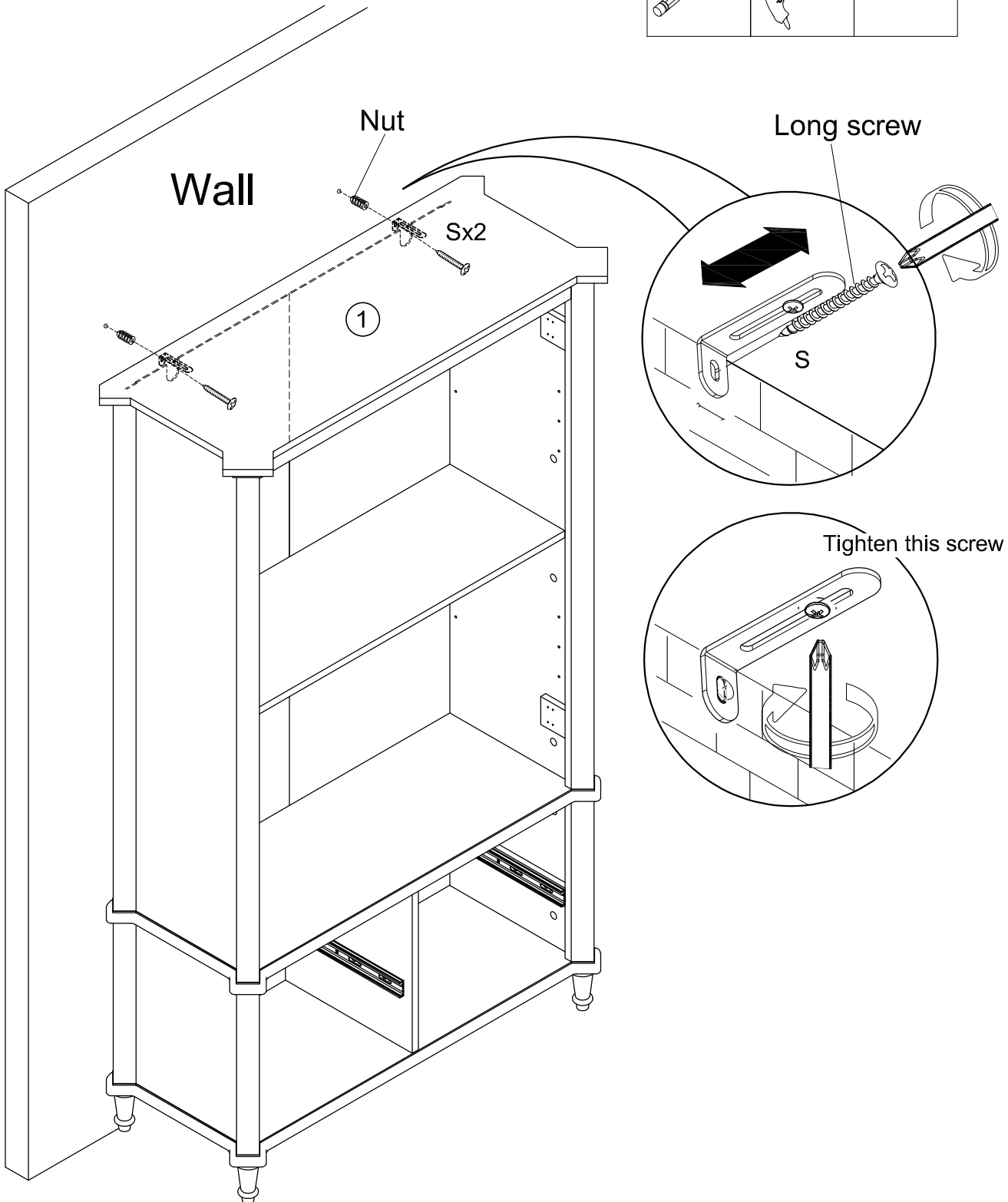
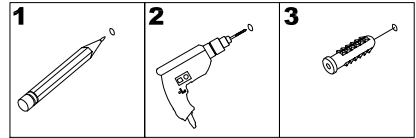

# STEP 21

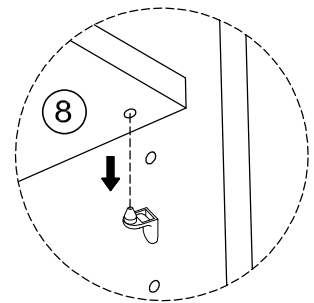
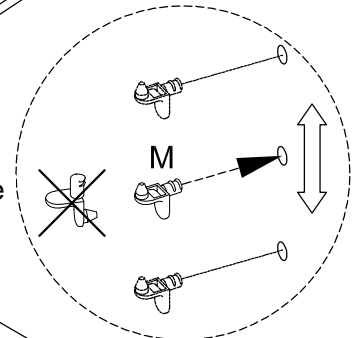
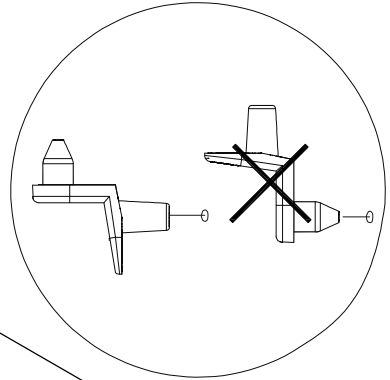
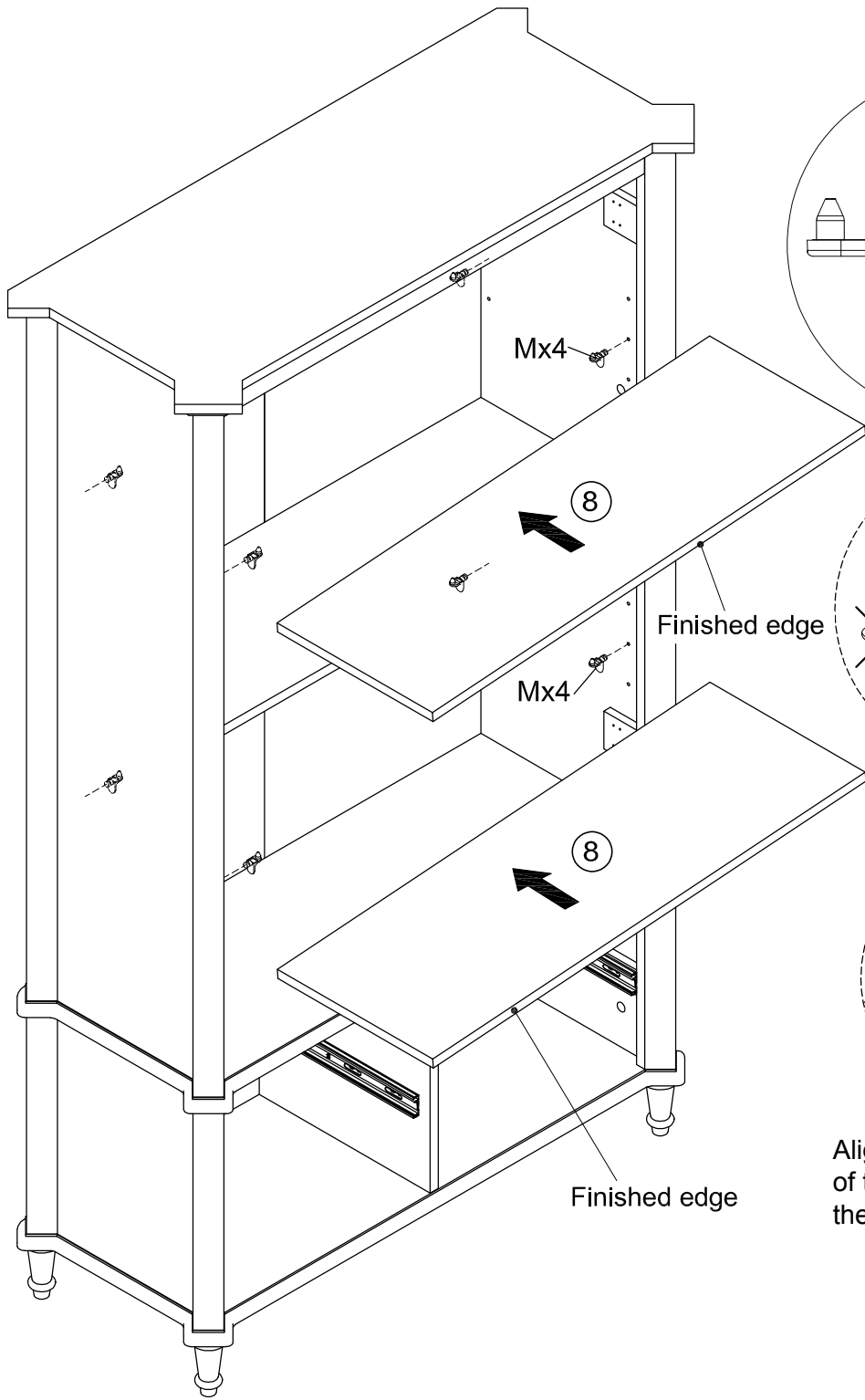

Align the holes at the bottom of the shelf with the shelf pegs, then press down.



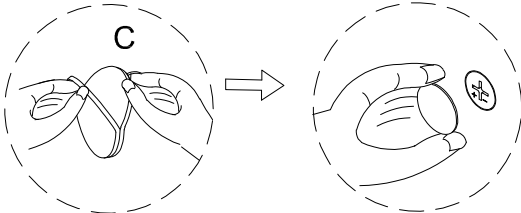
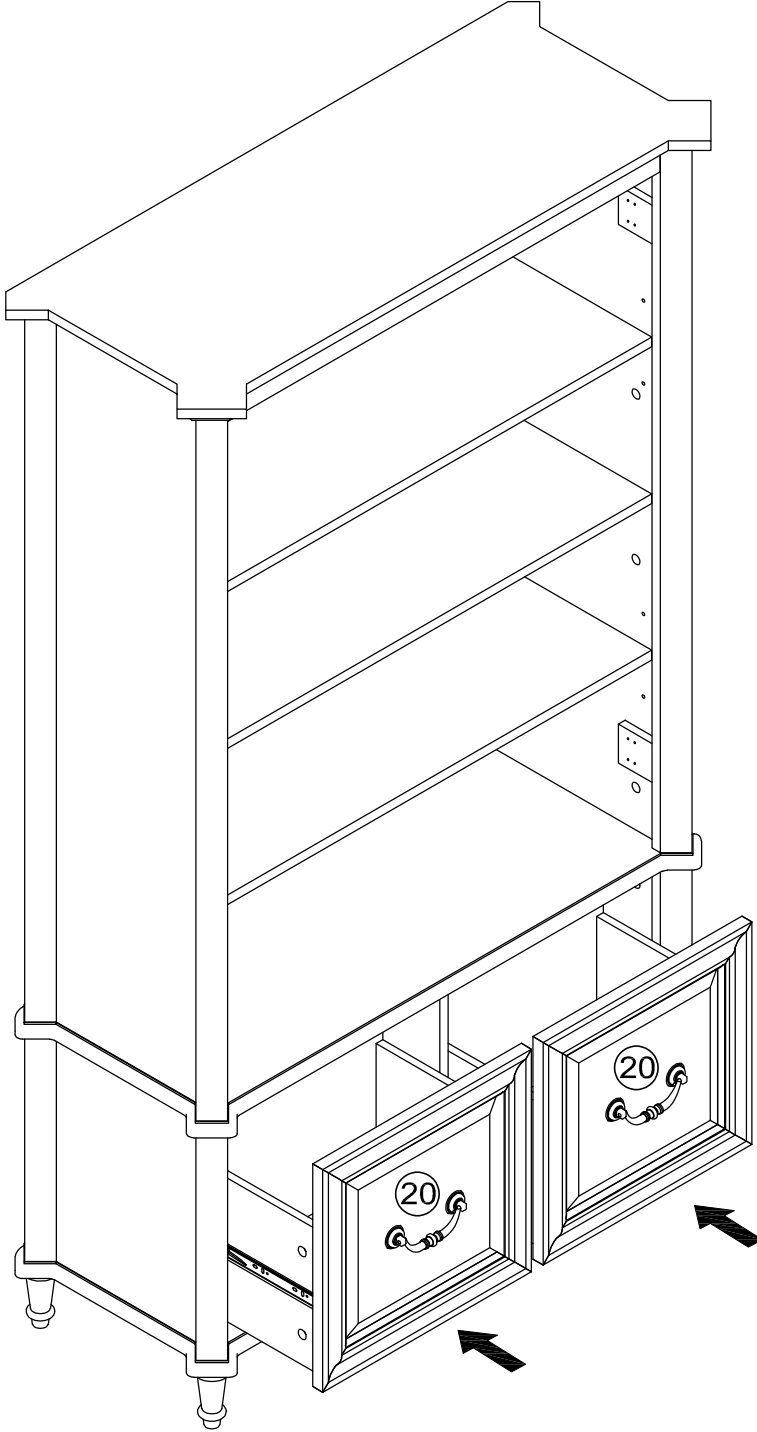
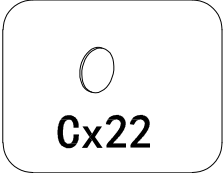

# STEP 22

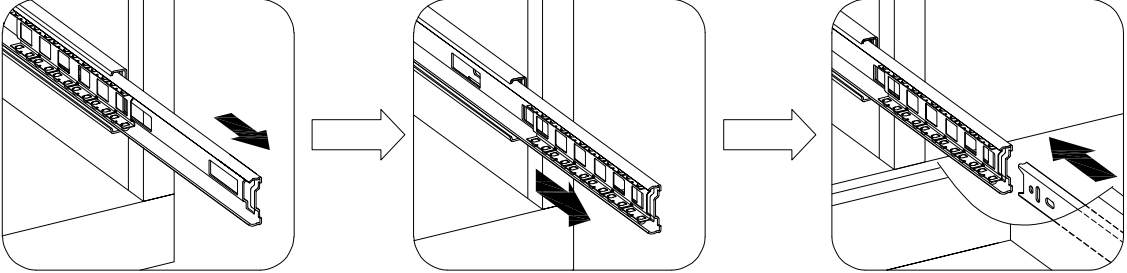

· Stick stickers (C) on cam locks (B).



# STEP 23

			
Hx2	Xx8	Jx2	Ox4

Power tools should not be used to assemble and adjust the doors.

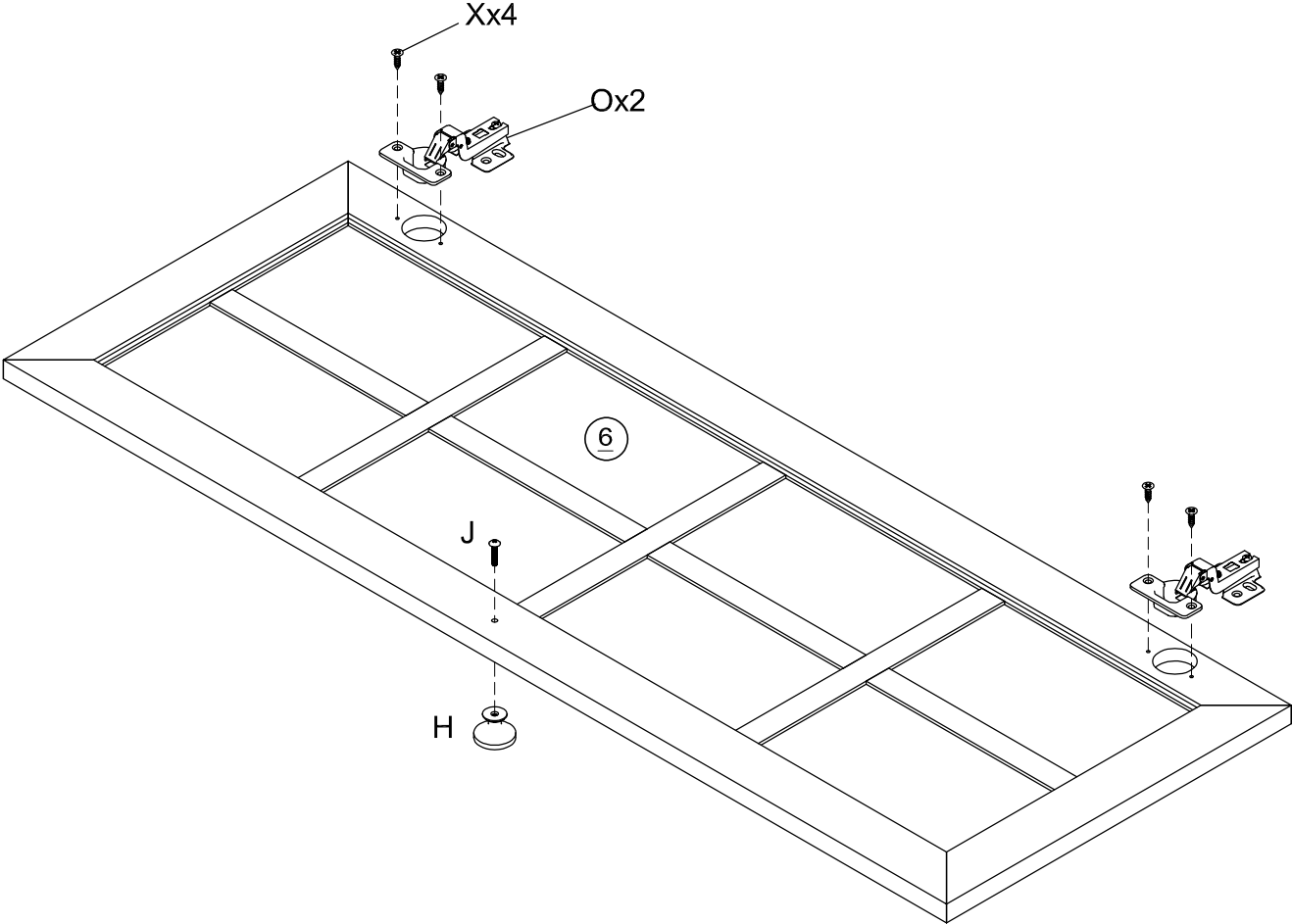
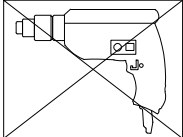

x2

# STEP 24

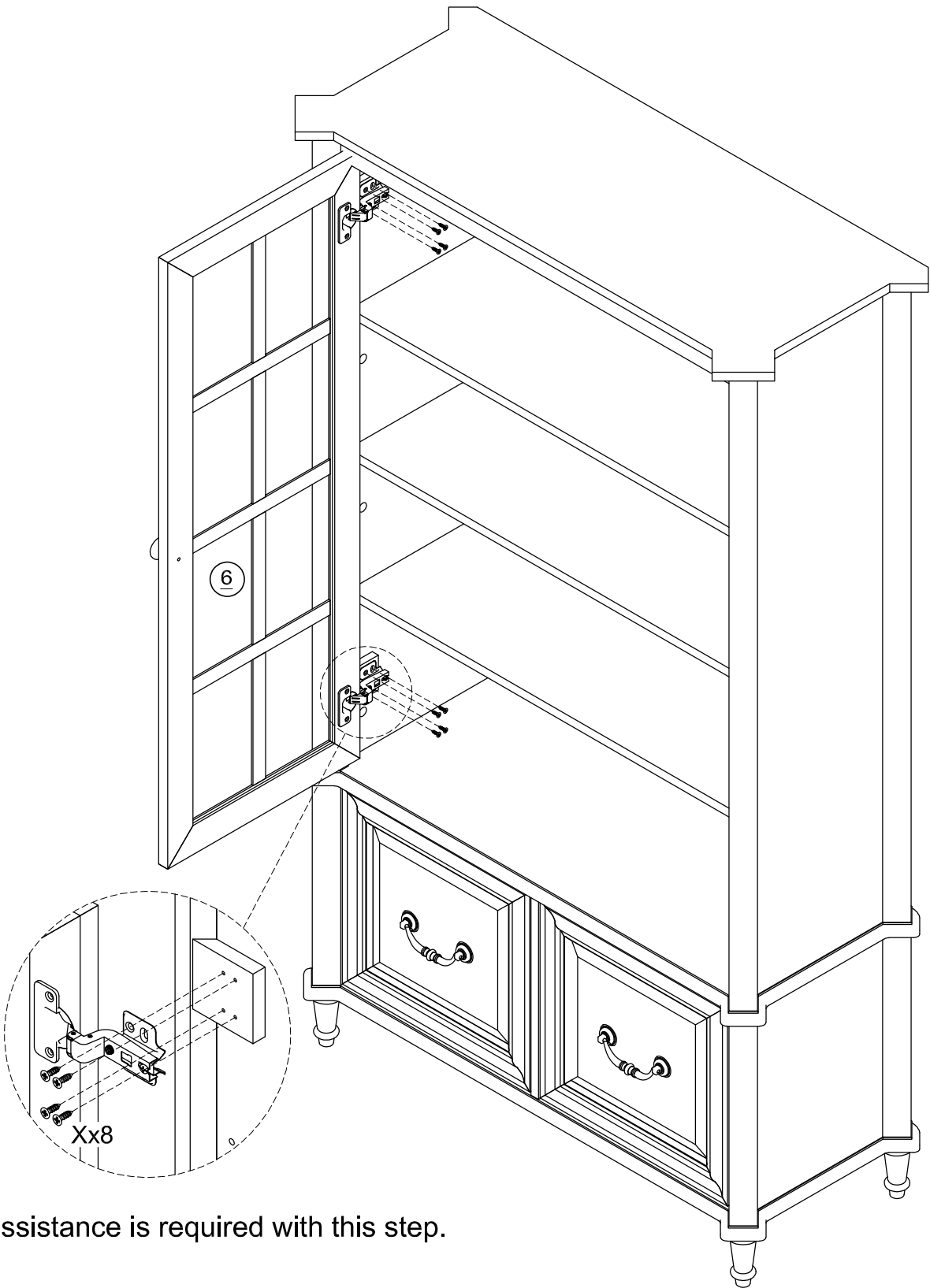
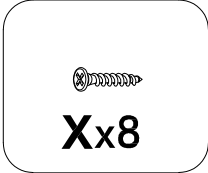

An assistance is required with this step.

# STEP 25

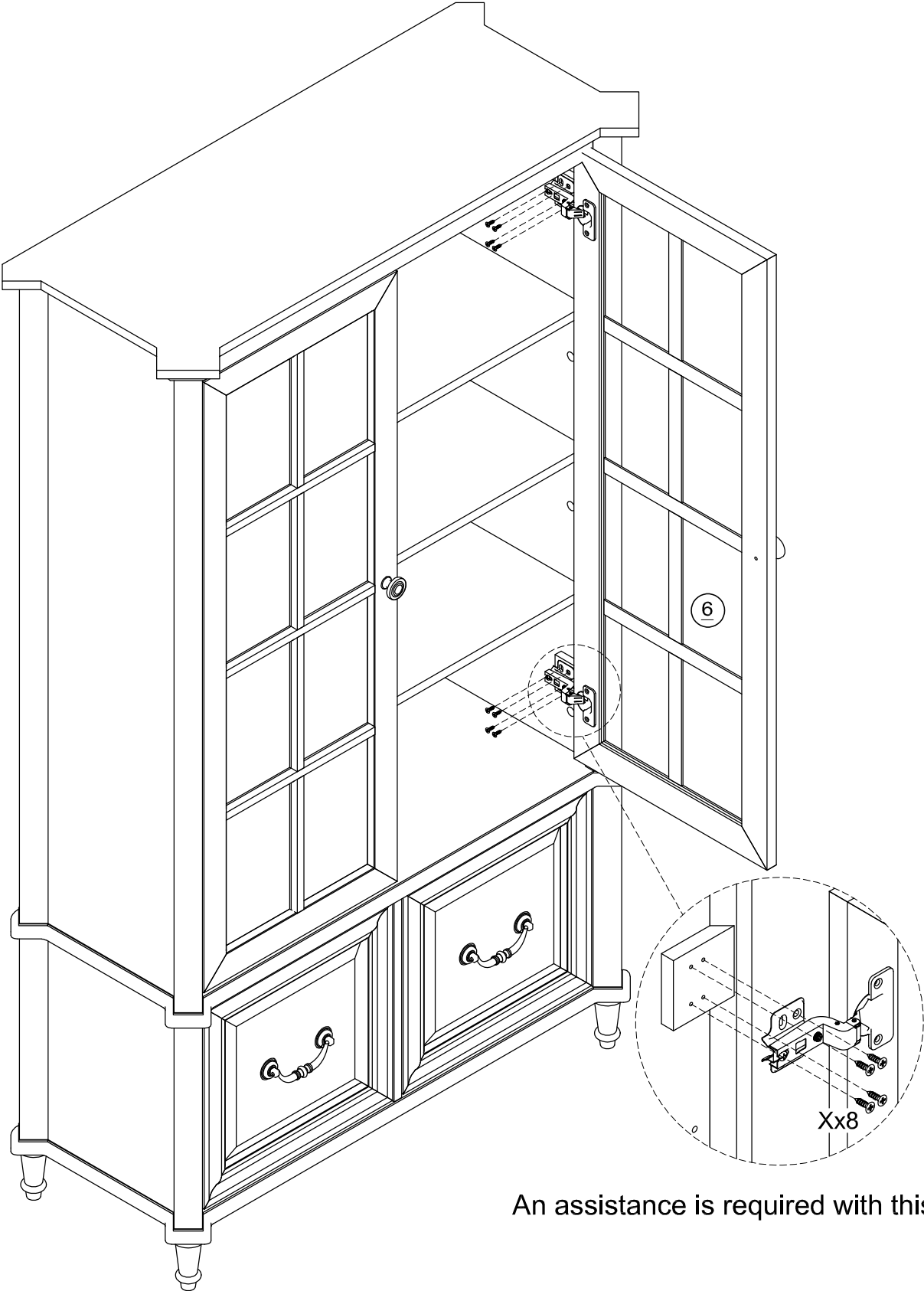
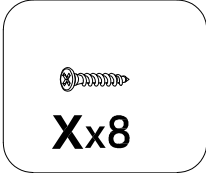

An assistance is required with this step.

# STEP 26

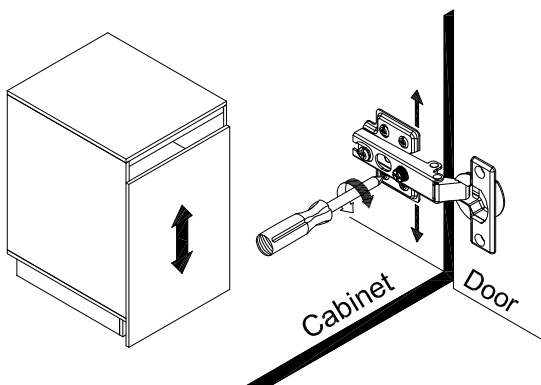
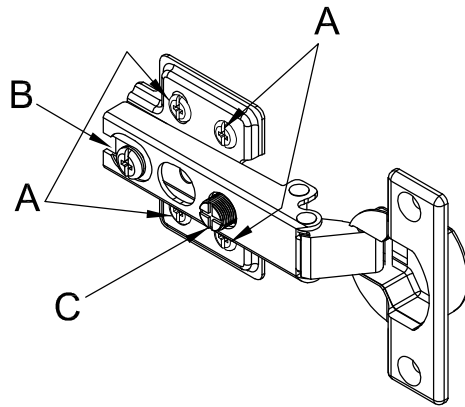

### To adjust the vertical height.

Loosen the four screws "A" on both hinges. Two of them are usually in slotted holes which allows you to adjust up or down by a few mm. Then tighten back up.

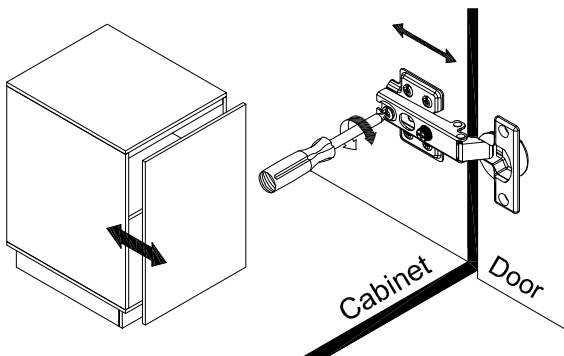

### To adjust depth.

Loosen screw "B" and adjust door, if the door can not be adjusted, please loosen screw "C", then try again. Tighten screw "B" and "C".

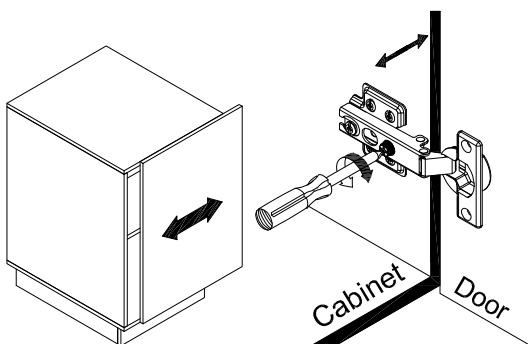

### To adjust side ways.

Turning the screw "C" on BOTH hinges on each door.

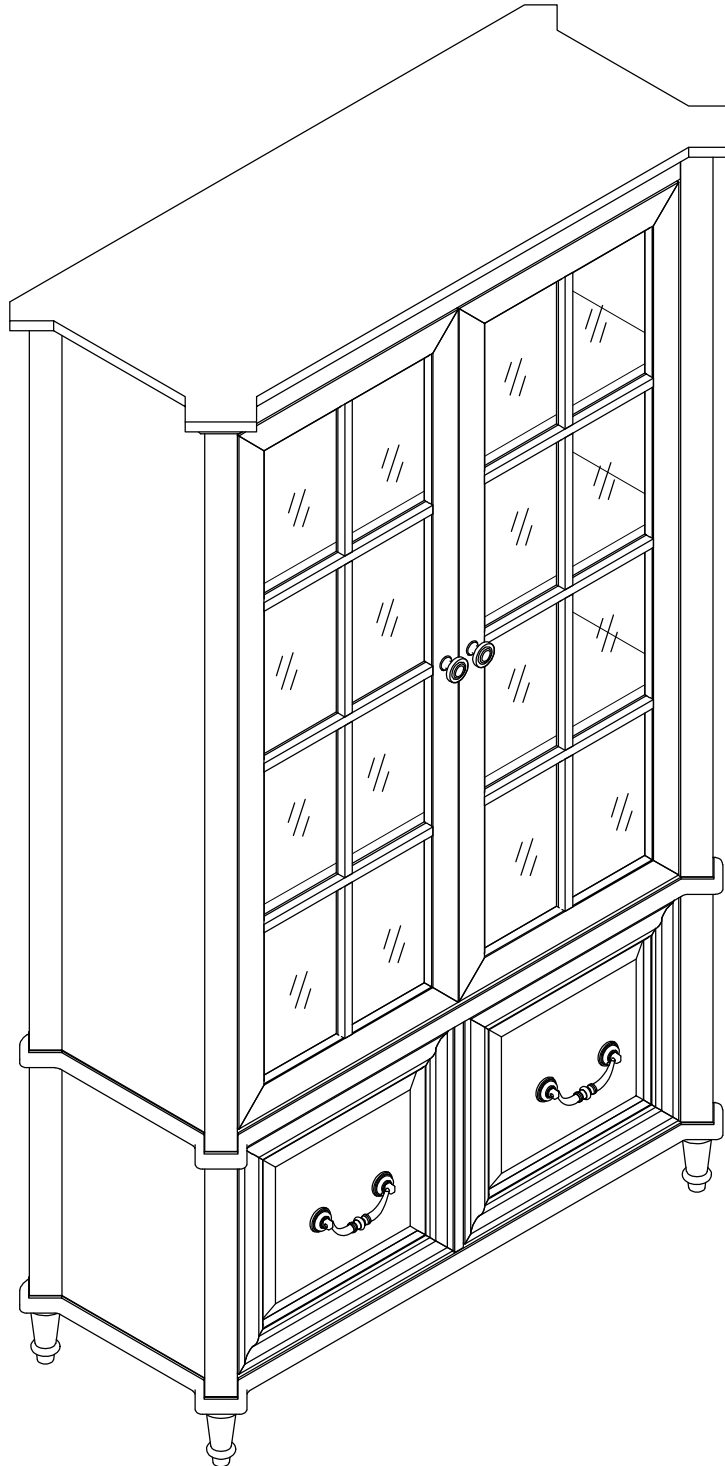

Final Assembly