

ASSEMBLY INSTRUCTIONS

HOPPER STUDIO

PRODUCT NAME : Delancey 3 Door Cabinet
 DIMENSIONS : 51" L x 15" W x 34" H
 ITEM NO. : 7161LN583AUJ09

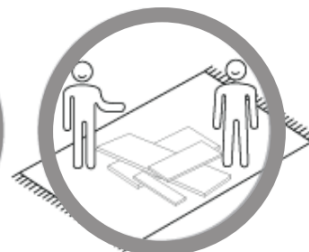
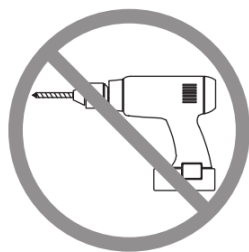
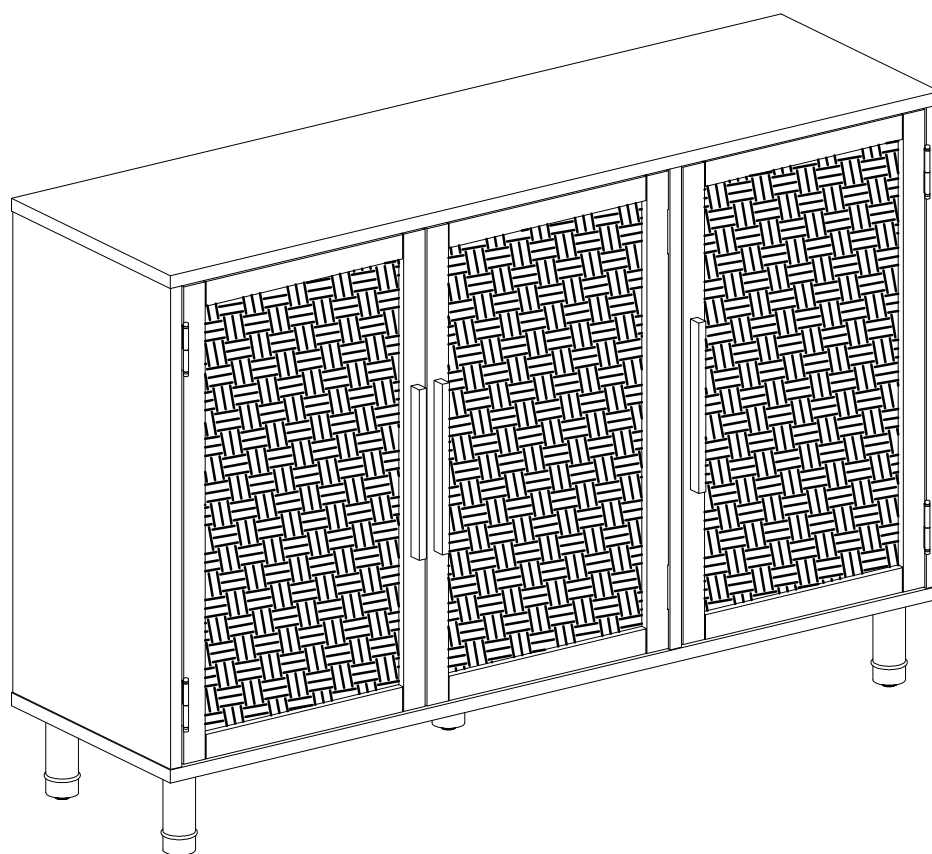

1. Check for damaged or missing parts . Call 1-800-696-8446 to order missing supplies.
2. Use a soft surface or the carton as a working surface to prevent damage during assembly.
3. It is recommended to have 2 adults on hand for assembly.
4. Gather all tools prior to assembly.
5. **WARNING!** When included, anti-tipping hardware **MUST** be installed for your safety.

how to use cam lock system

.....

1.

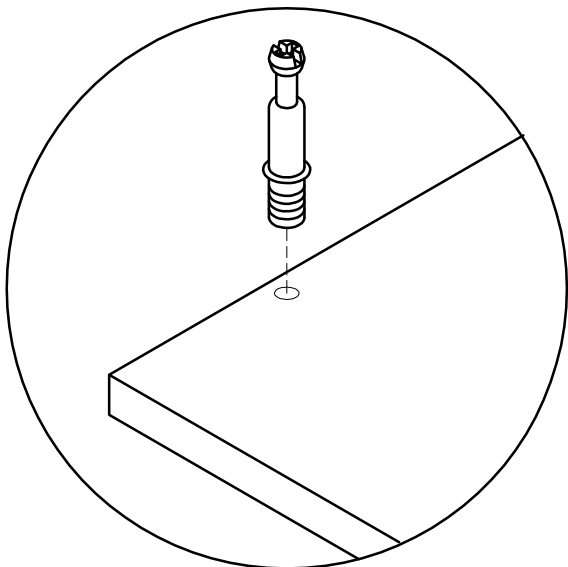

2.

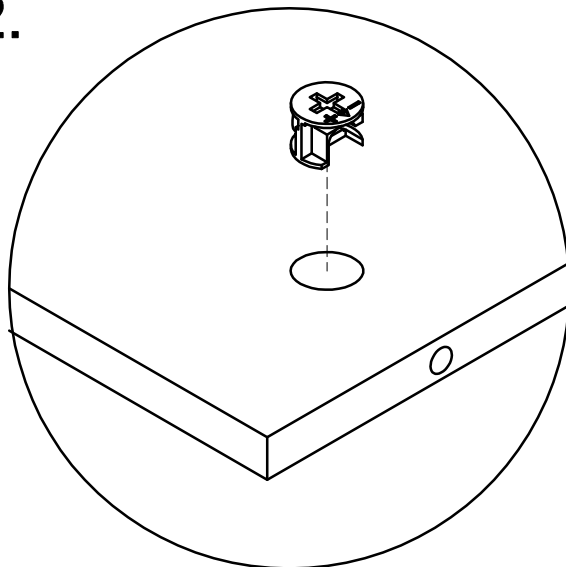

3.

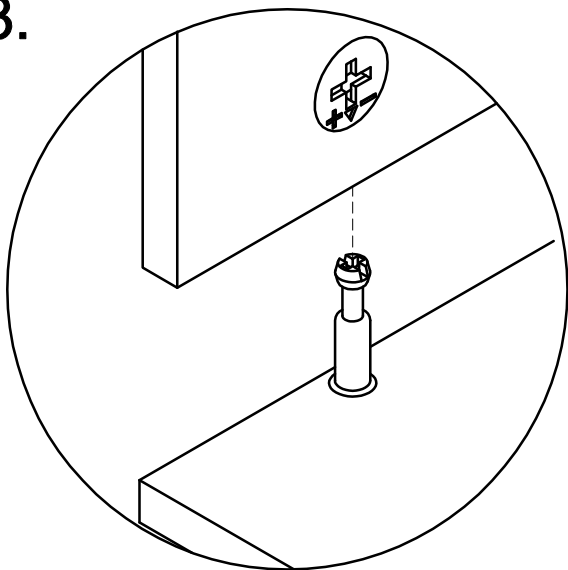



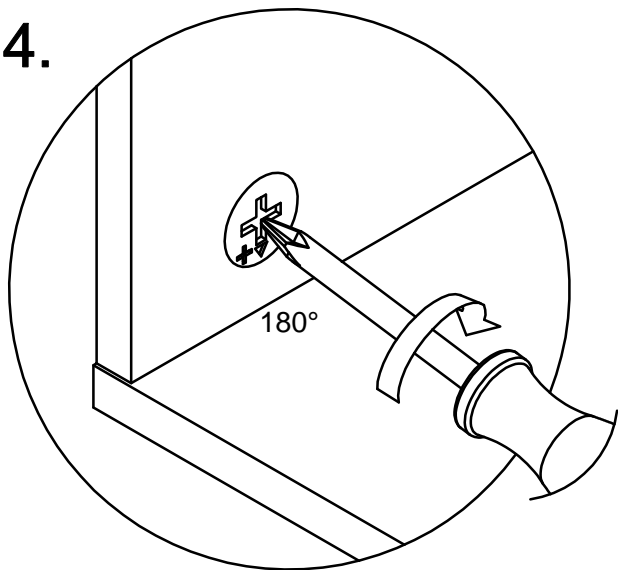



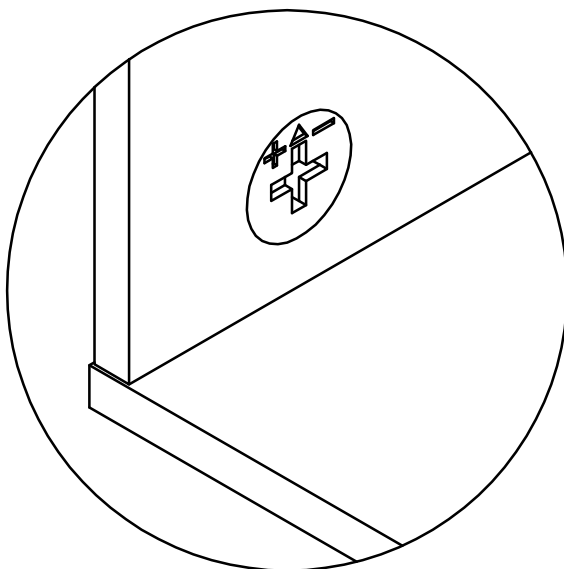

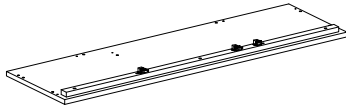
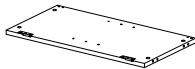
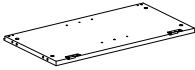
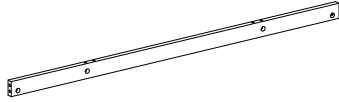
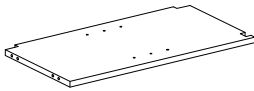
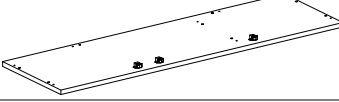

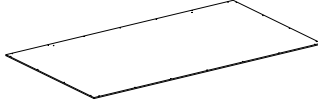

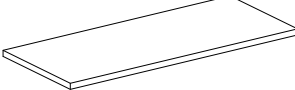
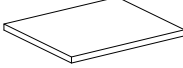

4.



5.

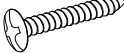

PARTS LIST:			QTY
A	Top Assembly		1pc
B	Left Side Panel		1pc
C	Right Side Panel		1pc
D	Back Rail		2pcs
E	Middle Panel		1pc
F	Bottom Panel		1pc
G	Leg		5pcs
H	Back Panel		1pc
I	Left Door		1pc
J	Right Door		2pcs
K	Left Shelf Panel		1pc
L	Right Shelf Panel		1pc
HARDWARE :			QTY
M	Wooden Dowel Ø8x40mm		20pcs
N	Cam Lock Bolt		20pcs
O	Cam Lock		20pcs
P	Screw with Washer Ø5/32" x 5/8"		22pcs
Q	Shelf Pin		8pcs
R	Plastic Anchor		2pcs
S	Bracket		4pcs
T	Screw Ø5/16" x 1"		2pcs

HARDWARE :			QTY
U	Screw Ø5/16" x 5/8"		2pcs
V	Cable		2pcs

STEP 1

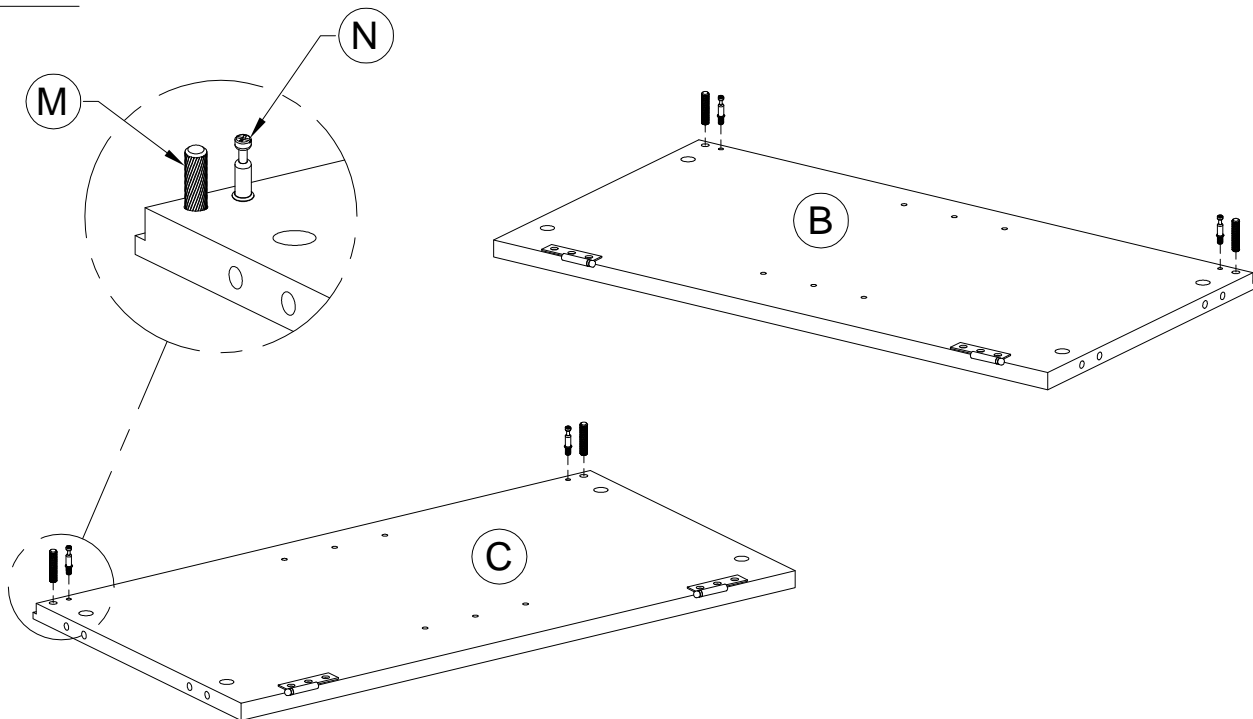

STEP 2

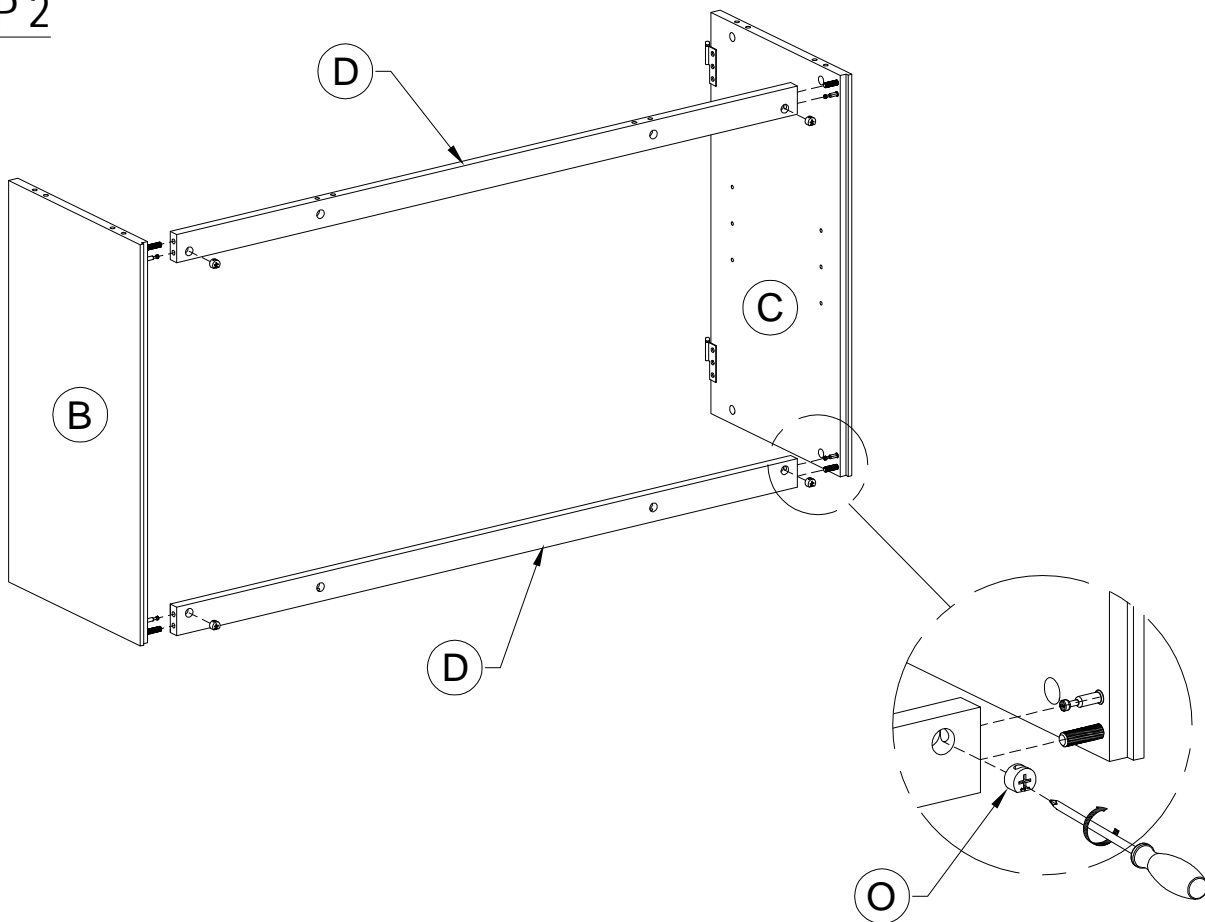

STEP 3

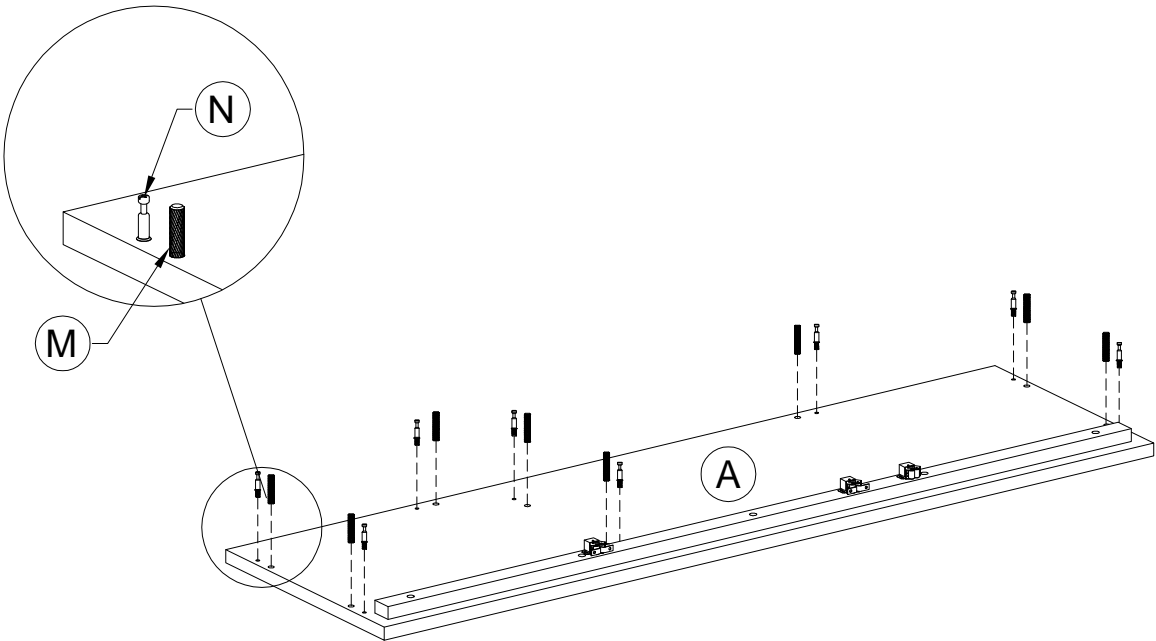

STEP 4

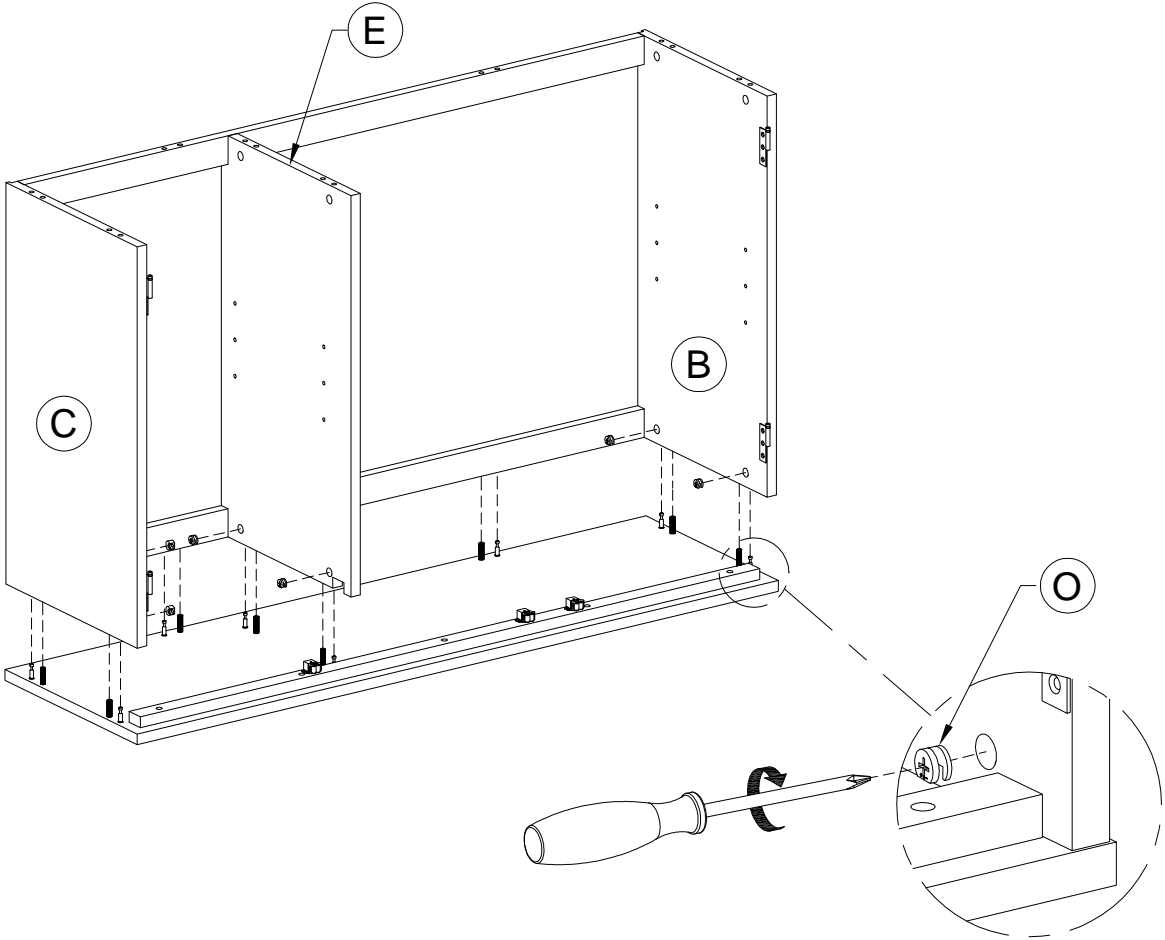

STEP 5

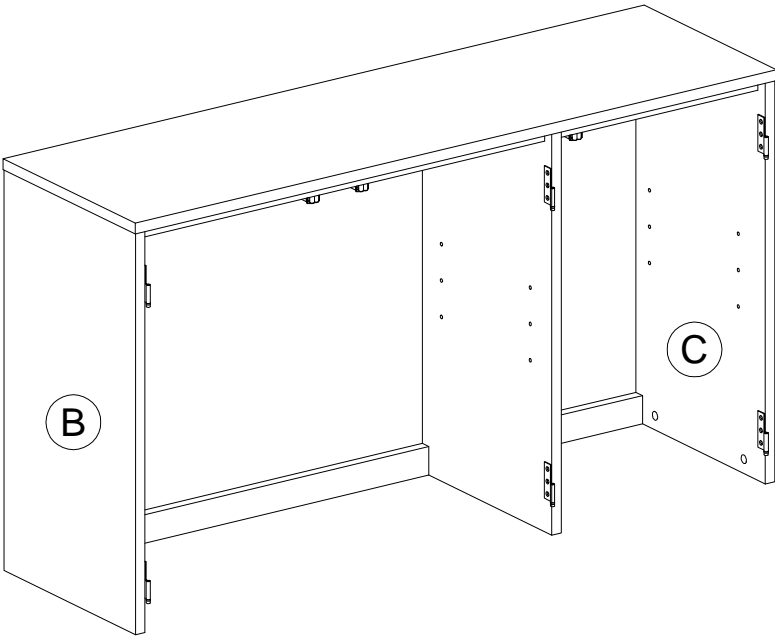
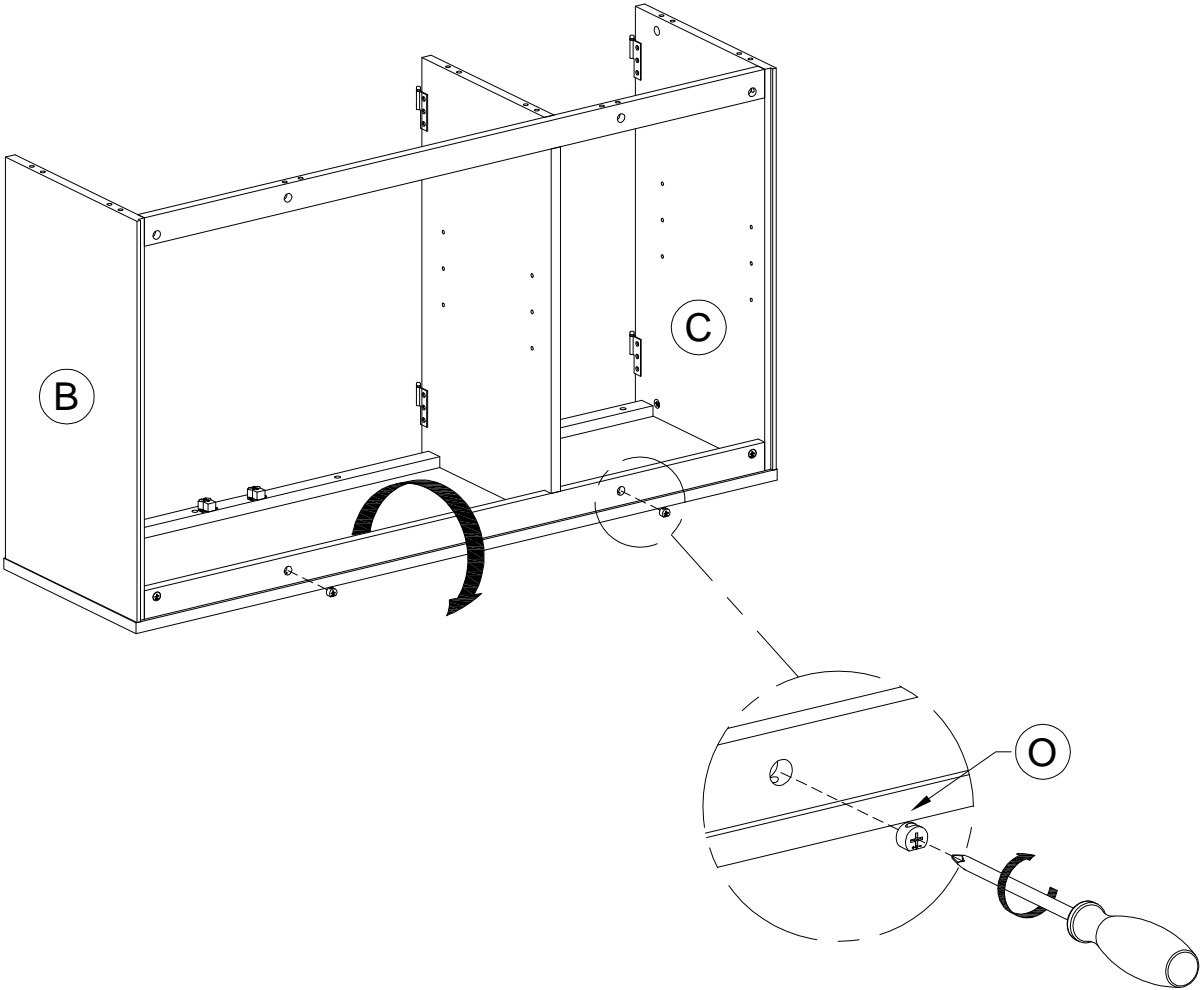

STEP 6

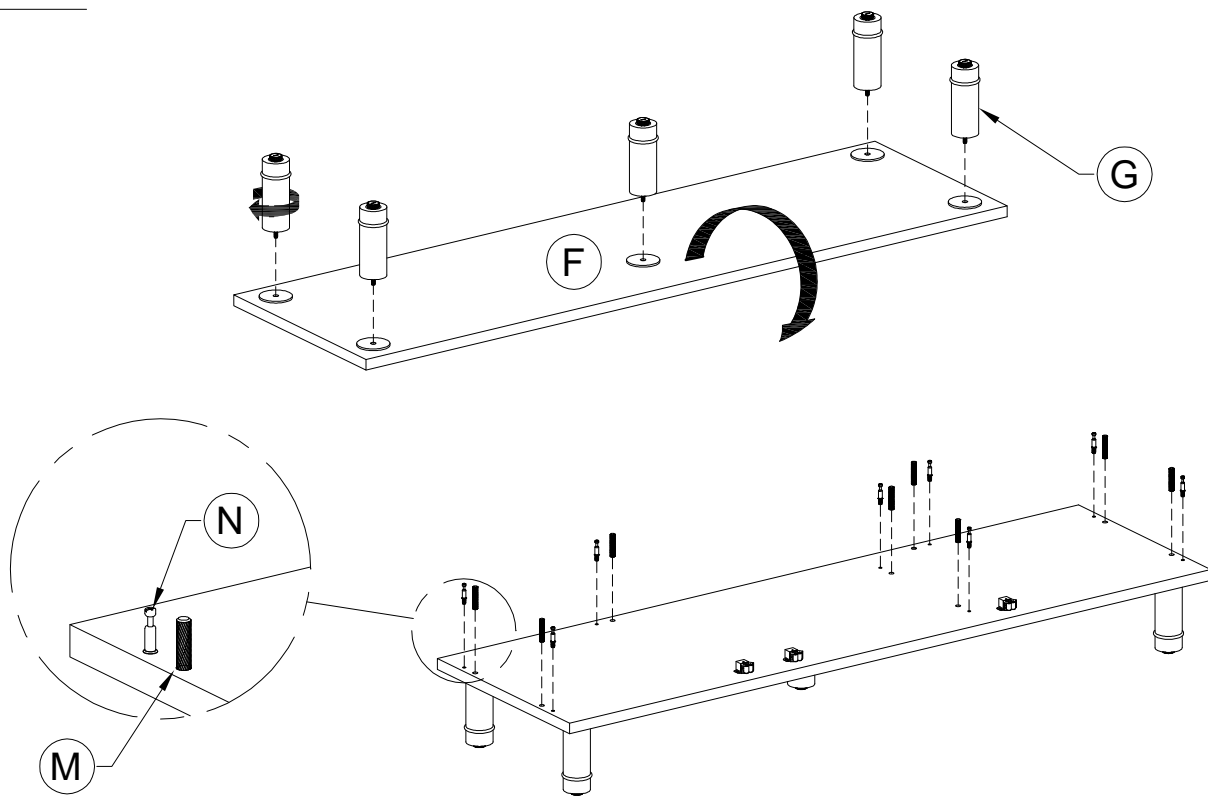

STEP 7

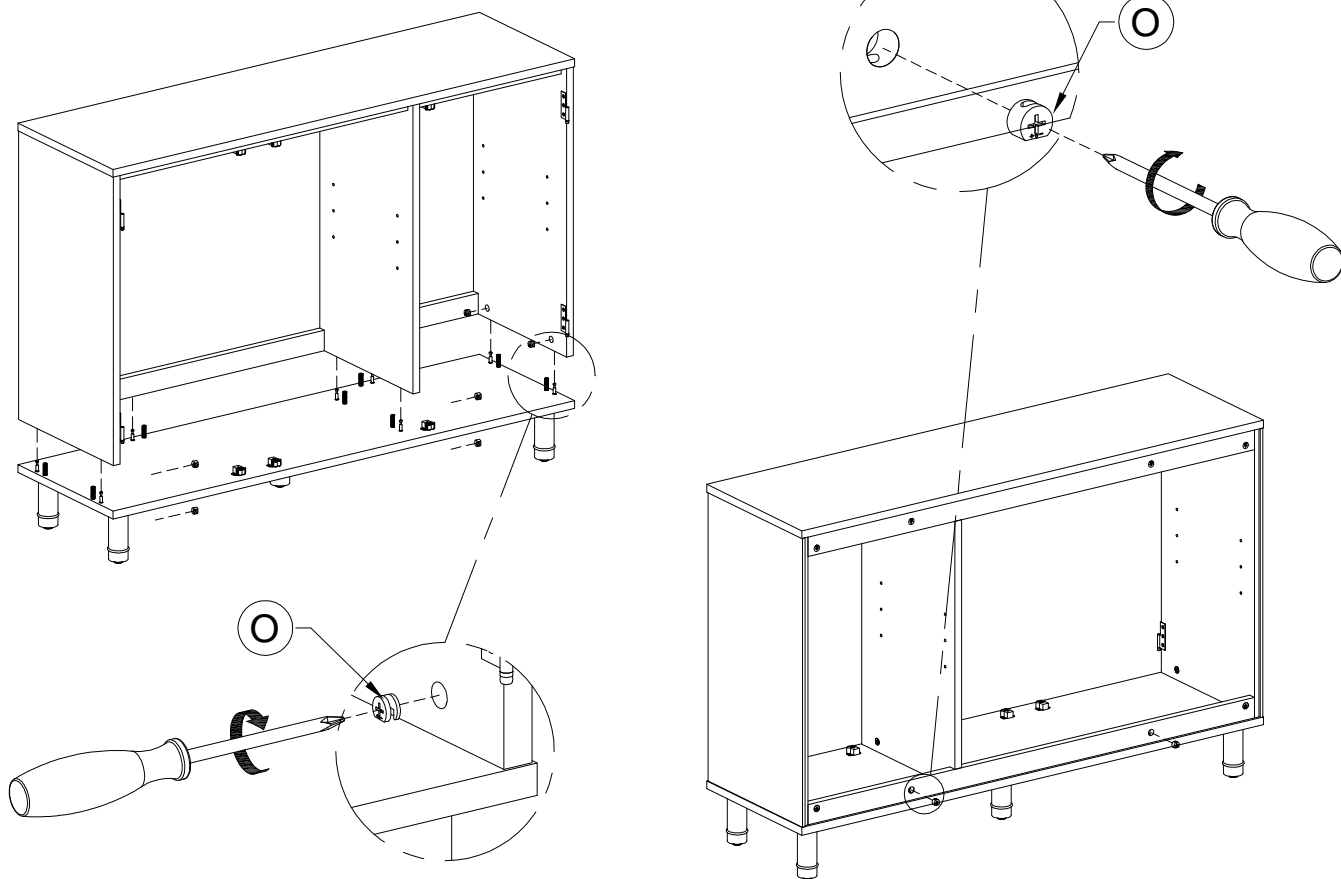

STEP 8

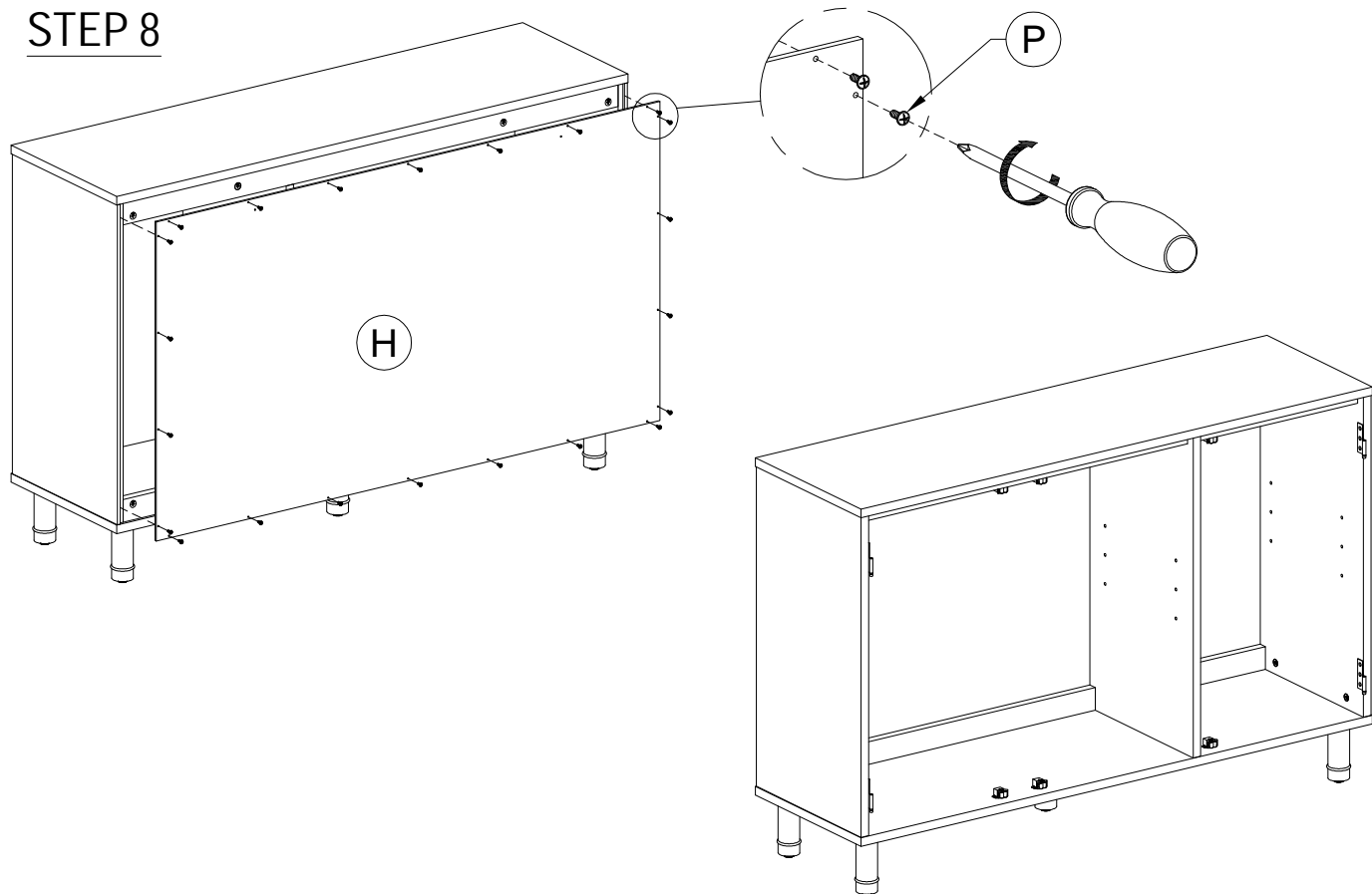

STEP 9

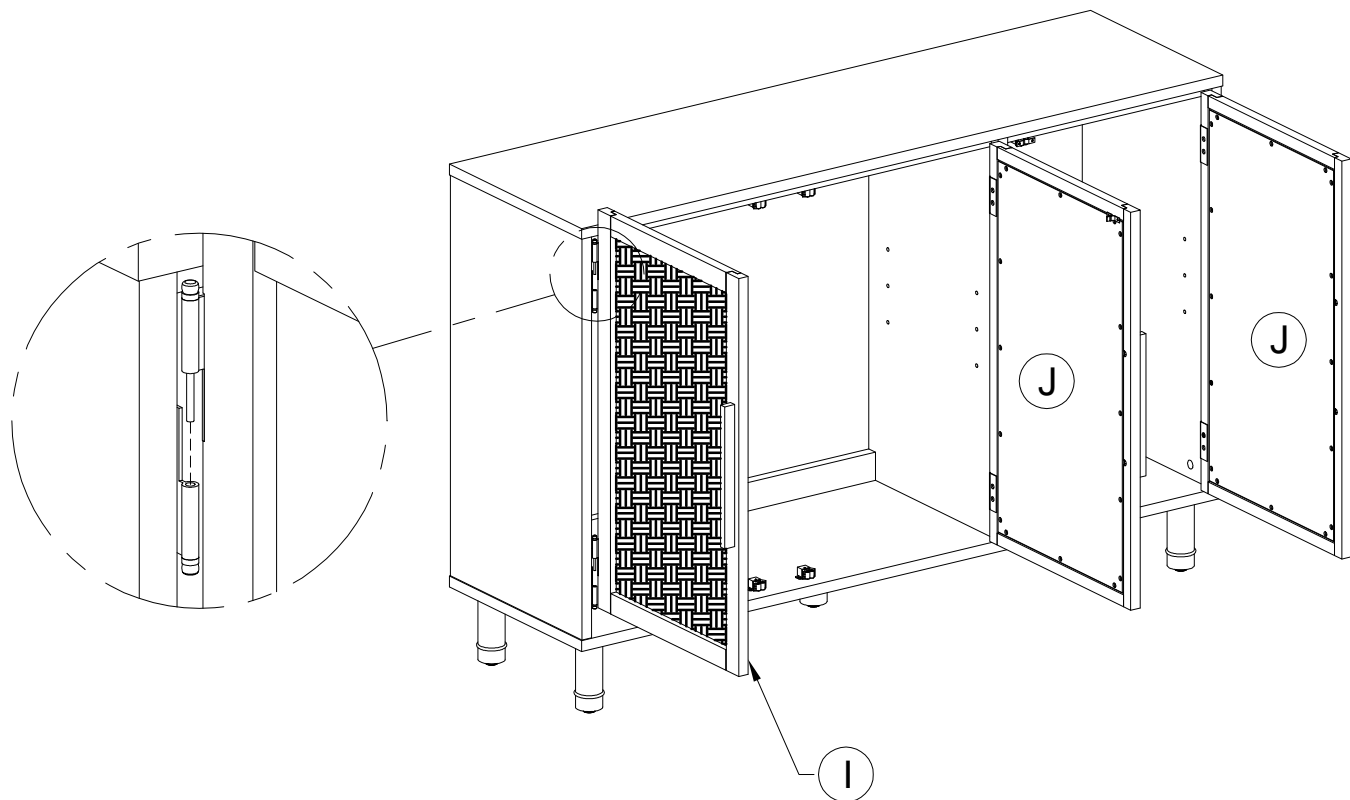

STEP 10

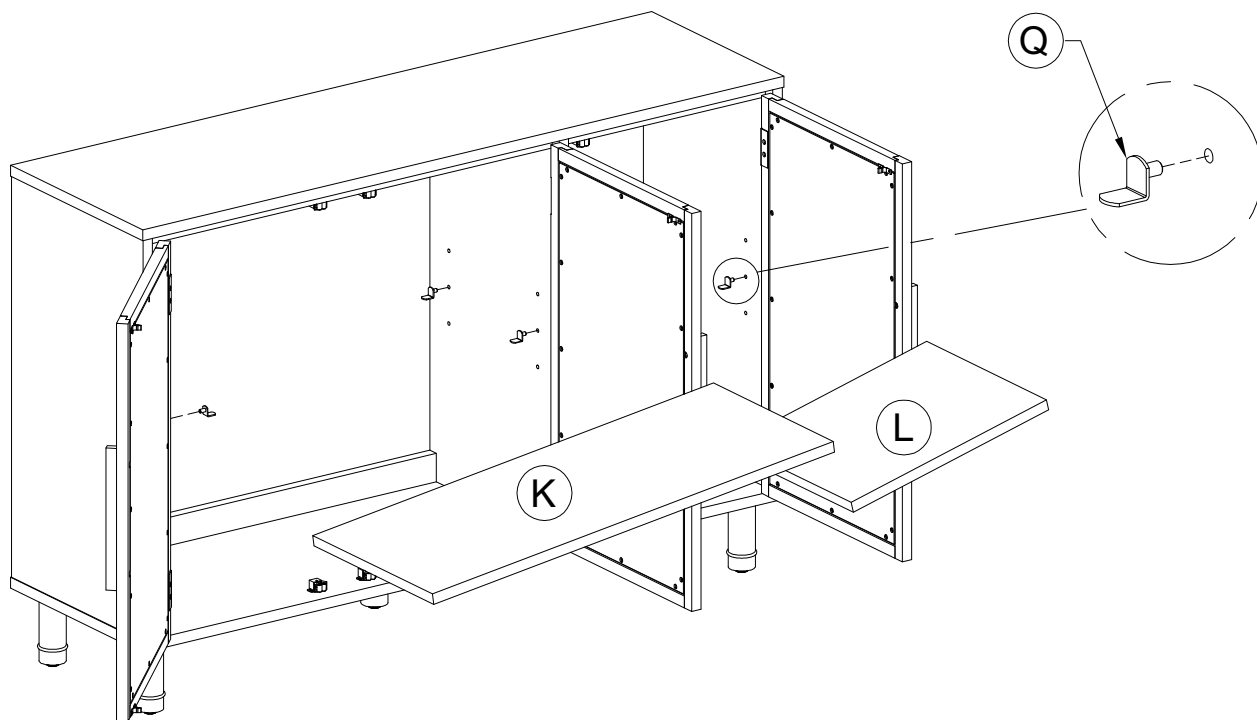

STEP 11

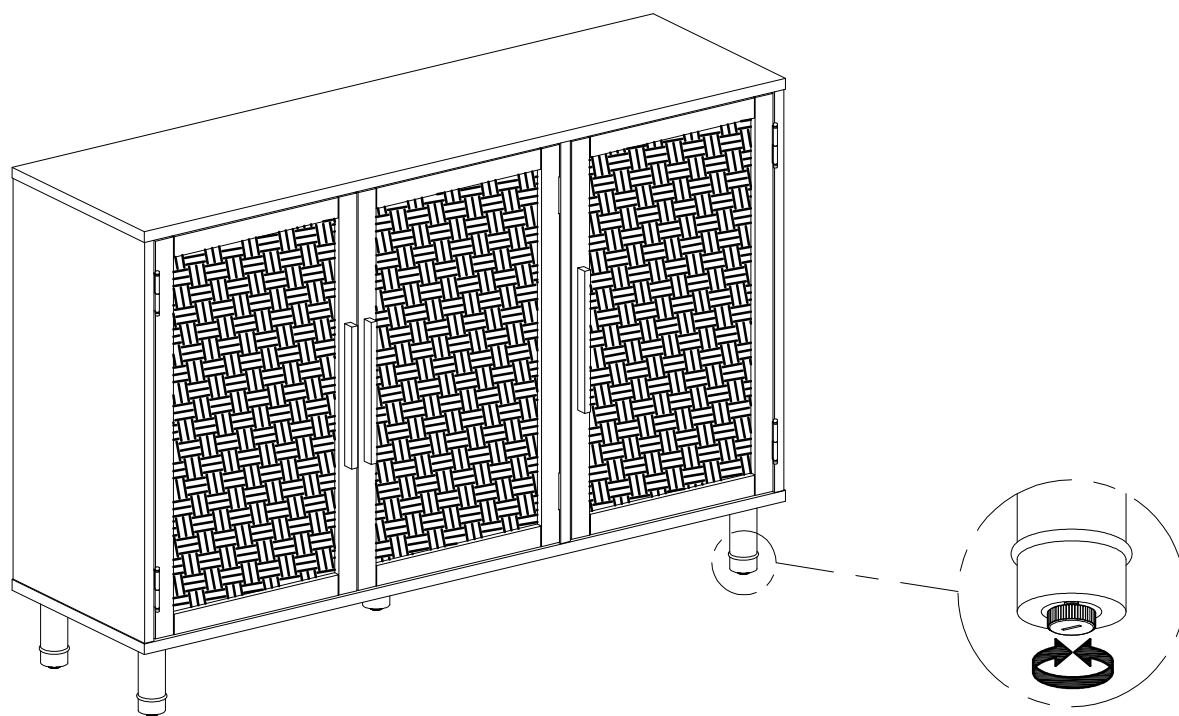

Note: adjust levelers on an uneven floor.

STEP 12

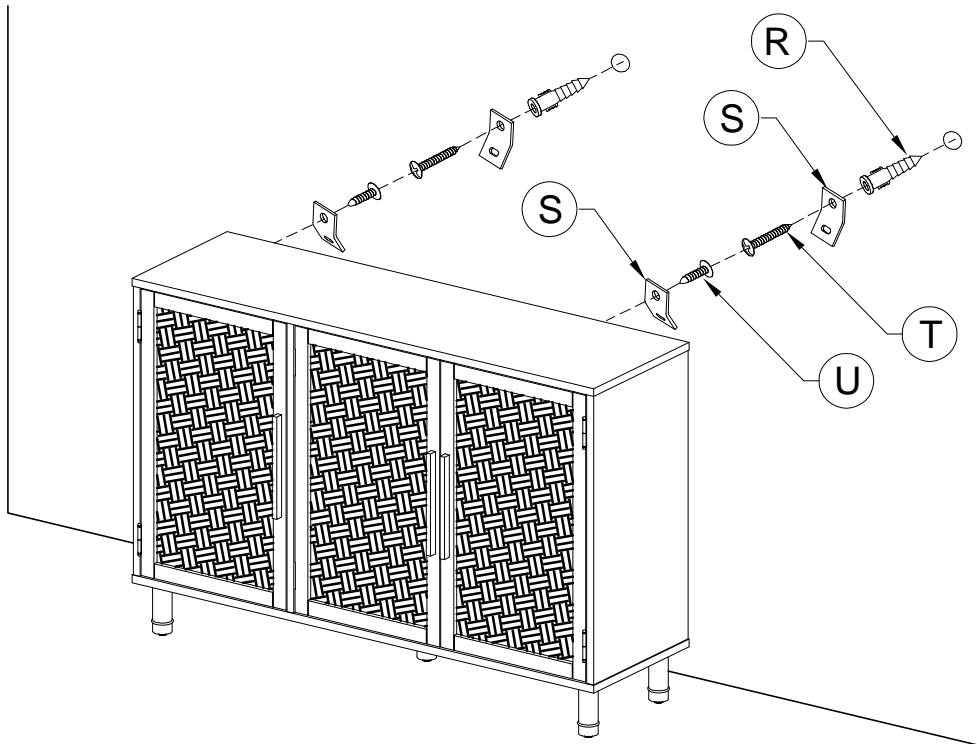

Note: The long screw included is suitable for most wall situations.
 Use appropriate screw for your application. Do not overtightened the cable.
WARNING! Anti-tipping hardware MUST be installed for your safety.

STEP 13

