

# INDUSTRIAL WRITING DESK

## ASSEMBLY INSTRUCTIONS

Thank you for purchasing our product

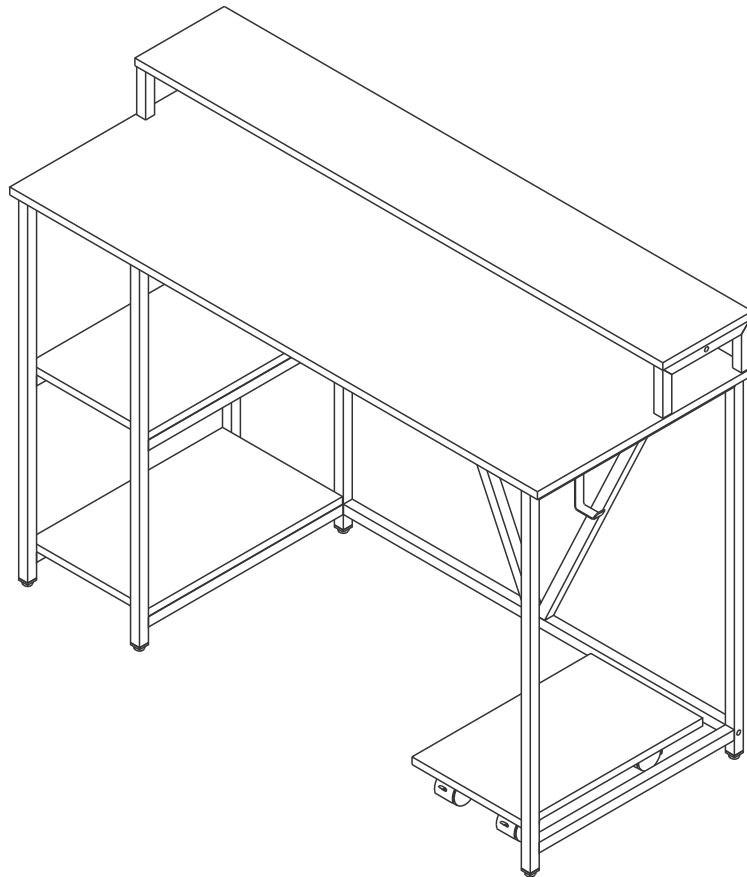

- Do not discard this manual or any of the packaging material until the unit has been completely assembled.



- Please read carefully the assembly instructions before the installation.



- The assembly might require of 2 persons for certain steps. Before you start the installation, make sure there is someone else nearby to help you.



- After the item is assembled, you can use rubbing alcohol to erase or remove the visible part numbers printed or labeled on the pieces.



- Please be kind to our planet, when done with the assembly, recycle any of the packaging materials that is accepted by your city or recycling service.



Do a quick inventory of all the parts and hardware listed below



Missing, damaged and defective parts can be replaced at no cost to you. Please refer to the last pages on this manual.



The replacement parts service is limited to the 48 contiguous United States. If you reside in AK, HI, PR, U.S. territories or other countries, please contact the supplier from where the unit was purchased.







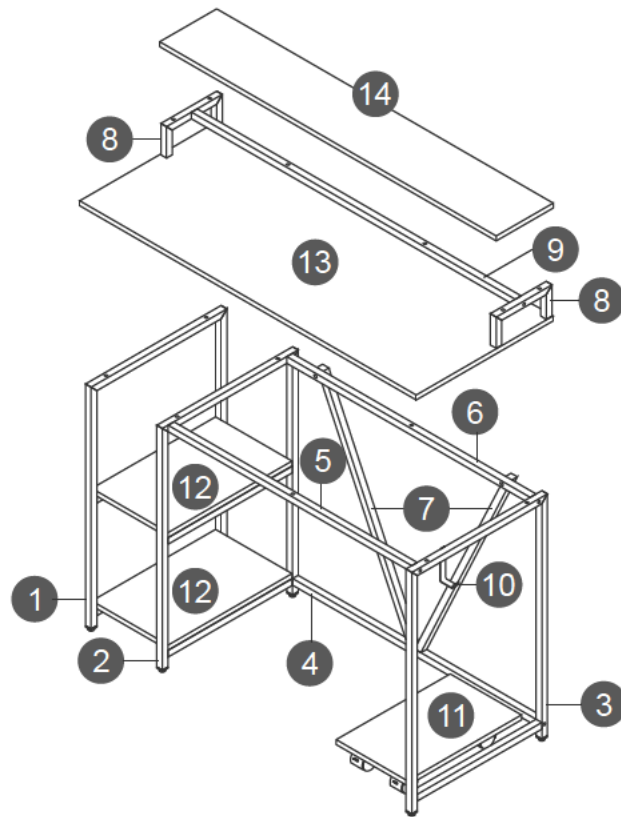

## MAIN PARTS LIST

<p><b>1</b> Left frame <b>x1</b></p>	<p><b>2</b> Middle frame <b>x1</b></p> <p>Frame #2 has more holes than frame #1</p>	<p><b>3</b> Right frame <b>x1</b></p>	<p><b>4</b> Bottom tube <b>x1</b></p> <p>33.5"</p> <p>2 holes on same side</p>
<p><b>5</b> Top-front tube <b>x1</b></p> <p>33.5"</p> <p>1 hole</p>	<p><b>6</b> Top-back tube <b>x1</b></p> <p>33.5"</p> <p>2 holes on same side, 1 hole on opposite side</p>	<p><b>7</b> Back support tube "V" <b>x2</b></p> <p>30"</p> <p>1 hole by the end</p>	<p><b>8</b> Top shelf support tube <b>x2</b></p>
<p><b>9</b> Top shelf horizontal tube <b>x1</b></p> <p>44.6"</p>	<p><b>10</b> Headphones hook <b>x1</b></p>	<p><b>11</b> CPU Panel <b>x1</b></p>	<p><b>12</b> Left shelf panel <b>x2</b></p>
<p><b>13</b> Main panel <b>x1</b></p>	<p><b>14</b> Top shelf panel <b>x1</b></p>		







**MAIN PARTS LAYOUT (For reference)**



**HARDWARE LIST**

PART	QTY	SIZE	ITEM
A	1	M6x12	 0 10 20 30 40 50
B	28	M6x30	 0 10 20 30 40 50
C	10	M6x45	 0 10 20 30 40 50
D	16	M3.5x12	 0 10 20 30 40 50
E	2	M6, 10x11mm	 0 10 20 30 40 50
F	2	Locking caster	
G	2	Non-locking caster	

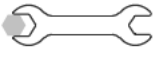
**INCLUDED TOOLS**

1	Phillips Screwdriver	 
1	M4 Allen Wrench	 
1	M10 Spanner	 

**BEFORE YOU START THE ASSEMBLY, PLEASE READ THE FOLLOWING TIPS AND WARNINGS.**

- Do not discard this manual or any of the packaging material until the unit has been completely assembled.



- If during assembly you find an issue or need clarification, please contact our Customer Service for assistance. Please refer to the last pages on this manual.



- On each step read the instructions thoroughly and analyze the illustrations before proceeding to do the assembly.
- Follow the instructions step by step and do not skip any unless our Customer Service advises it is OK to do so.



- Make sure you understand which hardware will be used on each step. Using the wrong size of screw, bolt or pin might strip the threads or cause damage to the part in which it is being used.

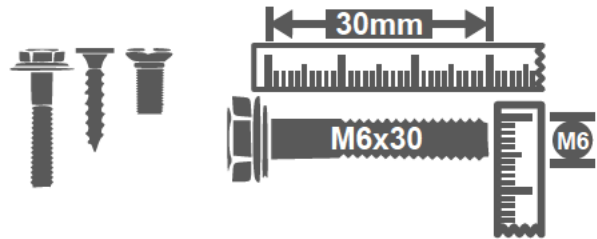

- To avoid misalignments, always leave the screws loose and tighten them until all pieces are positioned correctly.

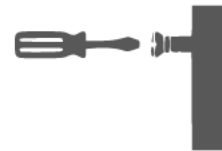

- Do not overtighten or force the screws as they might break, strip, damage the threads of the holes or get stuck inside the part.

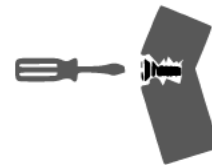

- If the hole seems too small for the screw, make sure you are using the correct size of screw and/or that you are installing it in the correct hole.



- Sometimes on the panels the laminate or material might be covering the hole partially or entirely. If there is no visible hole or it seems too small, pass and press the tip of your finger over the area where the hole should be located to feel its indentation, and once found, carefully pierce the laminate to uncover the hole underneath.



## ASSEMBLY STEPS

### STEP 1

#### Hardware

<b>B</b>	 M6x30	4 Pcs
----------	--	----------

#### Tools (included)



Assemble the first left shelf **12** to the middle bars on the frames **1** and **2** with screws **B** from underneath.

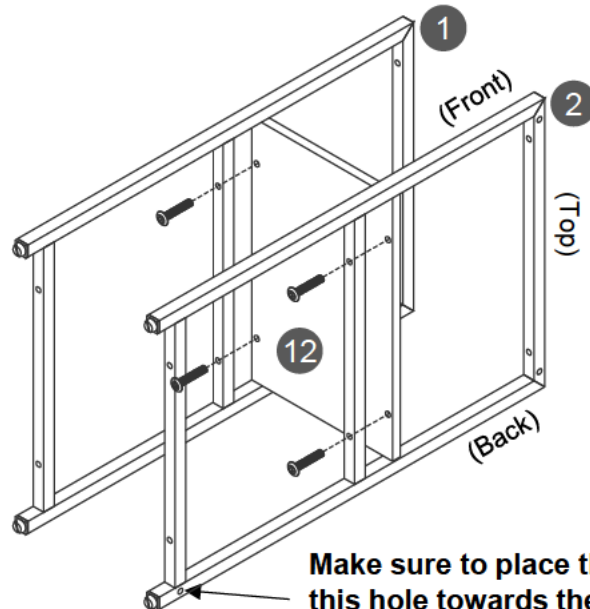

**Make sure to place the frame with this hole towards the back of the unit, it is needed for step 3.**

### STEP 2

#### Hardware

<b>B</b>	 M6x30	4 Pcs
----------	--	----------

#### Tools (included)



Scan QR to view step

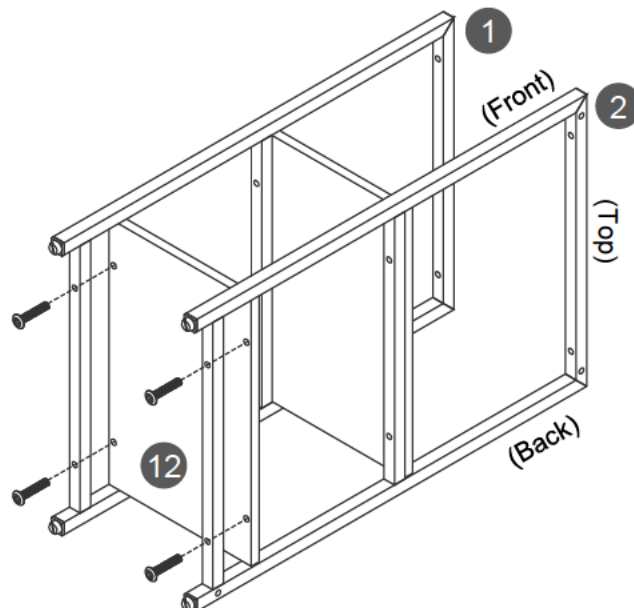

Assemble the second left shelf **12** to the bottom bars on the frames **1** and **2** with screws **B** from underneath.



**STEP 3**

This step requires of 2 persons 

**Hardware**

<b>A</b>	 M6x12	1 Pc
<b>C</b>	 M6x45	6 Pcs

**Tools (included)**



Scan QR to view step

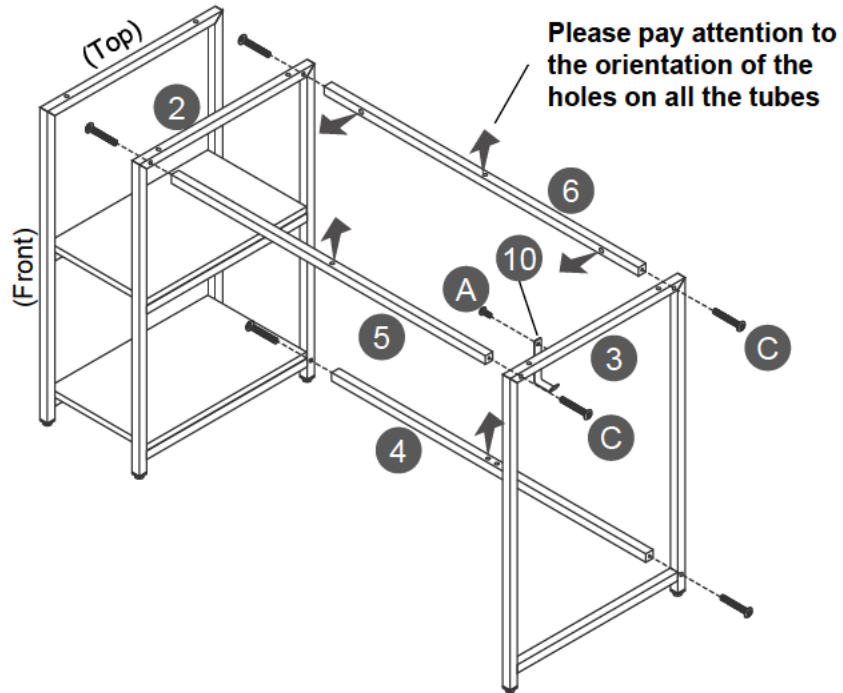

Bring the cabinet built in step 2 to the upright position, then with the help of another person:

- Assemble the tubes 4, 5 and 6 to the middle frame 2 in their respective positions with screws C.
- Assemble the right frame 3 to the tubes 4, 5 and 6 with screws C.
- Attach the hook 10 to the frame 3 with screw A from the inside.



**STEP 4**

**Hardware**

<b>B</b>	 M6x30	2 Pcs
<b>C</b>	 M6x45	2 Pcs
<b>E</b>	 M6	2 Pcs

**Tools (included)**

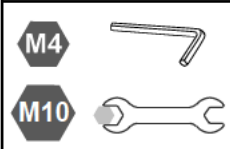

Scan QR to view step

- Assemble the support tubes 7 to the top tube 6 on the back of the unit with screws C from outside and nut caps E from inside.
- Assemble the support tubes 7 to the bottom tube 4 with screws B from underneath.

Note: If you don't see holes for the screws on the tubes 4 and 6, review step 3 for the correct assembly of those tubes.

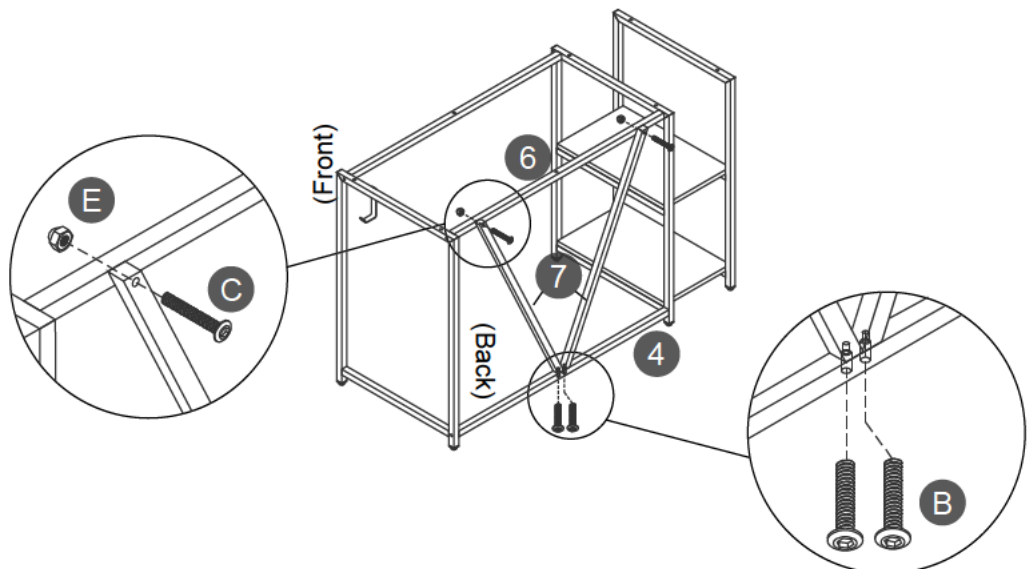

**STEP 5**

**Hardware**

**C**  2 Pcs  
M6x45

**Tools (included)**



Scan QR to view step



Assemble the top shelf support tubes **8** to the shelf horizontal tube **9** with screws **C**.

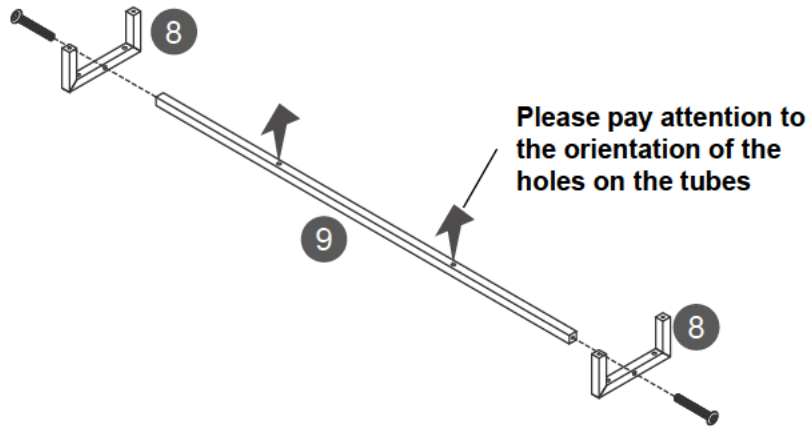

**STEP 6**

**Hardware**

**B**  6 Pcs  
M6x30

**Tools (included)**



Scan QR to view step

Assemble the tubes **8** and **9** to the top shelf panel **14** with screws **B**.

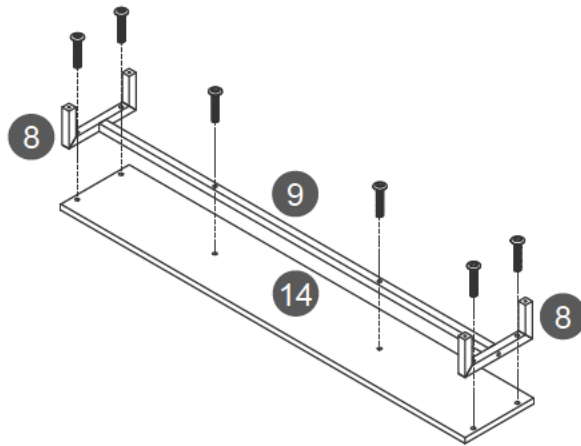

**STEP 7**

This step requires of 2 persons 

**Hardware**

**B**  4 Pcs  
M6x30

**Tools (included)**



Scan QR to view step

With the help of another person, assemble the main panel **13** to the tubes **8** with screws **B** making sure the bottom surface faces **UP** like shown in the illustration.

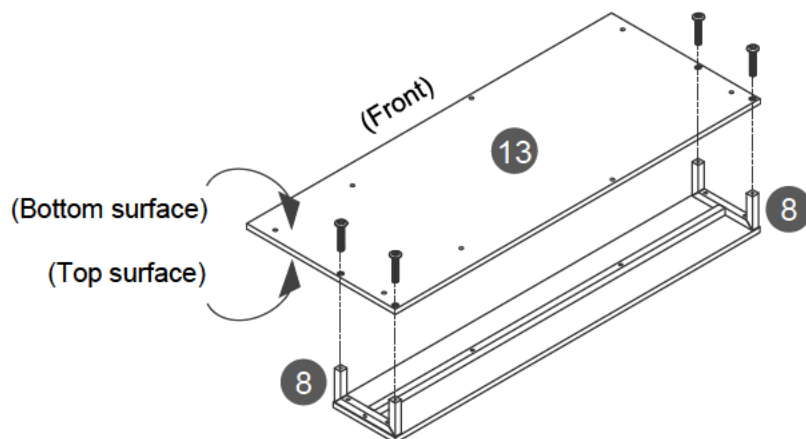

**STEP 8**

This step requires of 2 persons 

**Hardware**

**B**  8 Pcs  
M6x30

**Tools (included)**

**M4** 

Scan QR to view step

With the help of another person, assemble the main panel 13 to the frames 1, 2 and 3 and to the tubes 5 and 6 with screws B from underneath.

Note: If you don't see holes for the screws on the tubes 5 and 6, review step 3 for the correct assembly of those tubes.

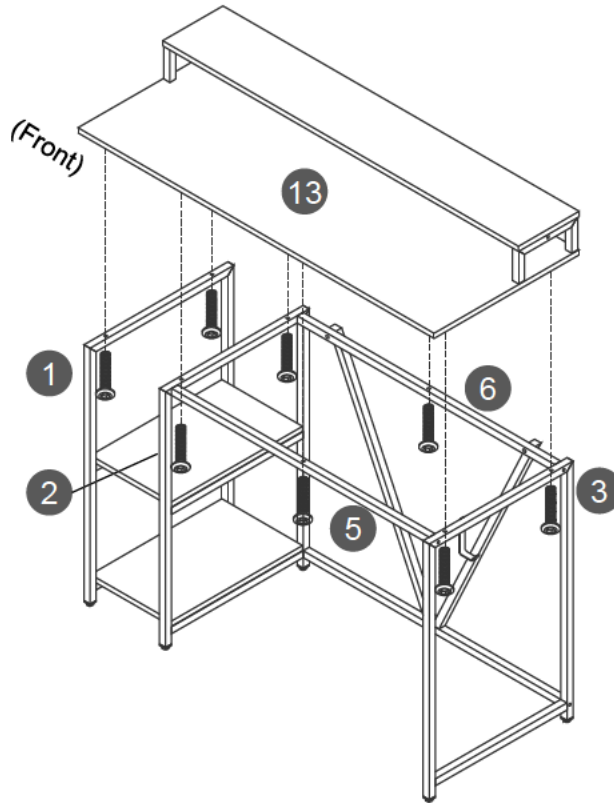

**STEP 9**

**Hardware**

**D**  16 Pcs  
M3.5x12

**F**  2 Pcs  
Locking

**G**  2 Pcs  
Non-locking

**Tools (included)**

Scan QR to view step

Assemble the casters F and G to the CPU panel 11 with screws D, making sure the Locking casters F are attached on the same side that will be considered the **FRONT** of the cart.

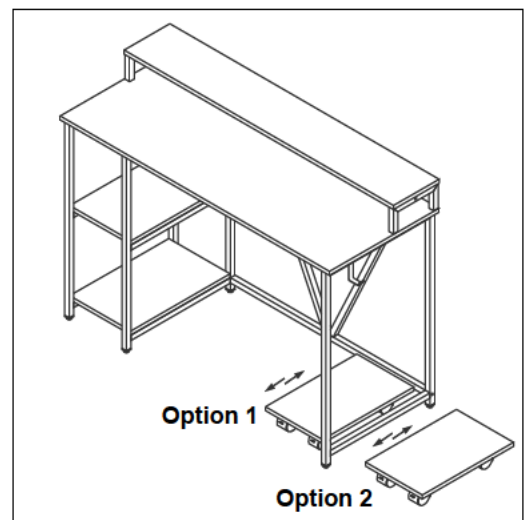
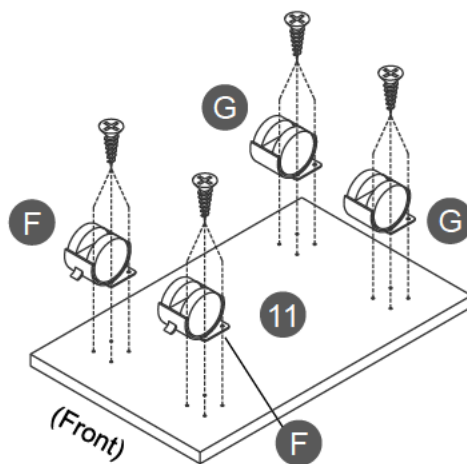

**ALL DONE!**

Give yourself a nice pat on the back, you did a great job!

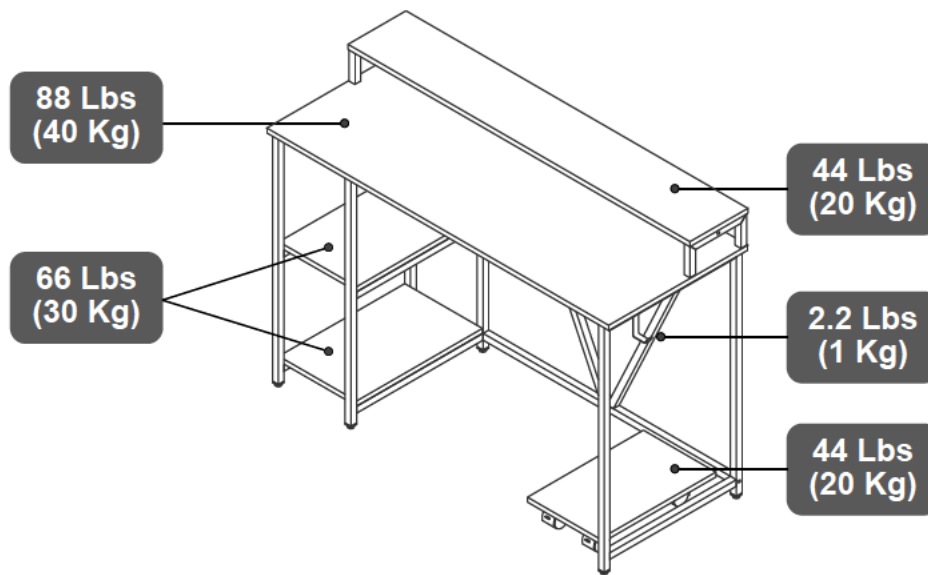
**WEIGHT LIMITS****WARNINGS**

- Do not exceed the indicated weight limits.
- Do not expose the surfaces to direct sunlight or to extreme environmental conditions.
- Do not use solvents or abrasive materials to clean the unit.
- Do not sit on the unit or lean against it.
- Do not allow small children to play under or over the unit.
- Do not allow small children to play with the CPU cart as a moving vehicle.
- Do not pull, push or drag the unit to move it for more than 1 feet. The unit must be lifted by at least 2 persons when moving in the same or adjacent rooms.
- Before moving the unit, make sure to secure or remove any object that is heavy or might fall off.
- When lifting the unit, use both hands and bend your knees, not your backs.

**CARE AND MAINTENANCE**

- Clean the surfaces preferable with a clean cloth damped in a solution of mild soap and water, then dry with a clean towel.
- If you decide to use a cleaning agent, test first on an area hidden from view such as underneath the tabletop.
- Every 4 months, inspect the unit completely and make sure that all screws are tighten.
- When transporting the unit to places far away, protect and secure the unit to avoid damage in transit.
- Shall any part of the unit become defective during the warranty period, replacement parts might be available to you at no charge. Please refer to the last pages on this manual.
- The warranty does not extend to regular wear and tear, nor the manufacturer assumes liability for damages or consequences due to accidents, incorrect assembly, negligence, improper use, modifications, or not heeding the above warnings.

Your satisfaction is very important to us. Our Support agents can help you with any issues you may have, please feel free to contact us with any questions you have about our products, or to request replacement parts.

---

---