

ASSEMBLY INSTRUCTIONS

INSTRUCCIONES DE ARMADO

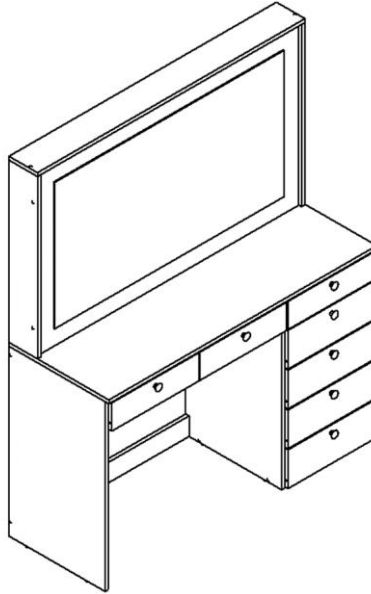

DRESSING TABLE WITH MIRROR

Tocador con Espejo

Aprox. product weight 105.02 lbs. / 47,71 Kg. *

THIS INFORMATION BOOKLET CONTAINS IMPORTANT SAFETY INFORMATION. PLEASE READ AND KEEP FOR FUTURE REFERENCE.
ESTE FOLLETO CONTIENE INFORMACIÓN DE SEGURIDAD IMPORTANTE. POR FAVOR, LEA Y GUÁRDELO PARA REFERENCIA FUTURA.

GENERAL SAFETY INFORMATION

1. Please read the Assembly Instructions prior to assembling this product.
2. Remove all the hardware from the box and sort by type.
3. Check to see that all the hardware and parts are present BEFORE assembling.
4. To avoid damage, assemble the product on a sturdy, level, and protective surface.
5. Please wait until all steps are completed before fully tightening bolts.
6. Make sure all bolts are tightly fastened before the unit is used.
7. To move the product, you must lift it. DO NOT drag it, if you drag it can cause overturning.
8. **This product is sold with a hardware kit to be fixed on the wall. You must install this kit to prevent any accidents or damages. When properly installed, this restrain can provide protection against the unexpected tipping of the unit due to small tremors, bumps or climbing. The restrain is only a deterrent and is not a substitute for proper adult supervision. Use of tip-over restraints may only reduce, but not eliminate, the risk of tip-over**

INFORMACIÓN GENERAL DE SEGURIDAD

1. Lea las instrucciones de armado antes de ensamblar este producto.
2. Extraiga todo el hardware de la caja y ordene por tipo.
3. Verifique que todo el hardware y las piezas están presentes ANTES de ensamblar.
4. Para evitar daños, ensamble el producto sobre una superficie resistente, nivelada y con protección.
5. Espere hasta que todos los pasos se hayan completado antes de apretar completamente los tornillos y accesorios.
6. Asegúrese de que todos los tornillos y accesorios estén bien apretados antes de usar la unidad.
7. Para mover el producto debe levantarlo. NO lo arrastre, si lo arrastra puede causar volcamiento.
8. **Este producto se vende con un kit de accesorios para ser fijado en la pared. Debe instalar este kit para evitar accidentes o daños. Cuando se instala correctamente, esta restricción puede proporcionar protección contra la inclinación inesperada de la unidad debido a temblores pequeños, golpes o al treparse. La restricción es solo un elemento disuasivo y no es un sustituto de la supervisión adecuada de un adulto. El uso de restricciones de vuelco solo puede reducir, pero no eliminar, el riesgo de volcarse.**



General Dimensions / Dimensiones Generales

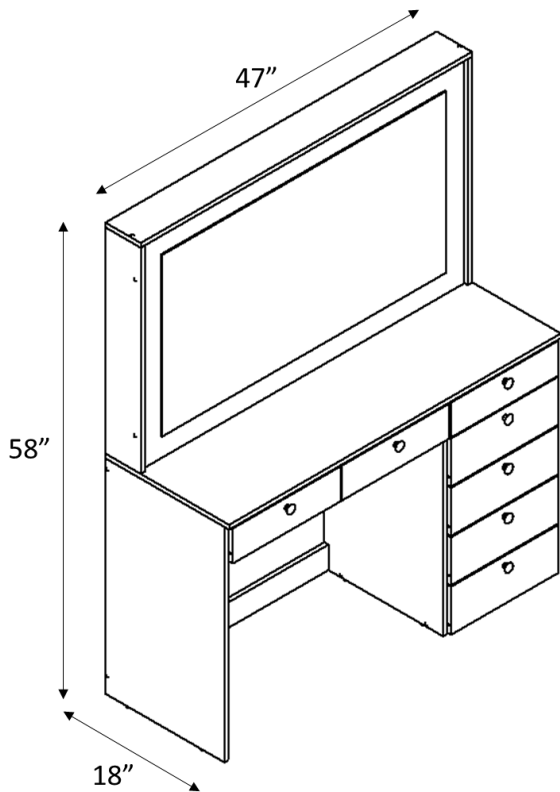

Maximum weight supported / Peso máximo soportado

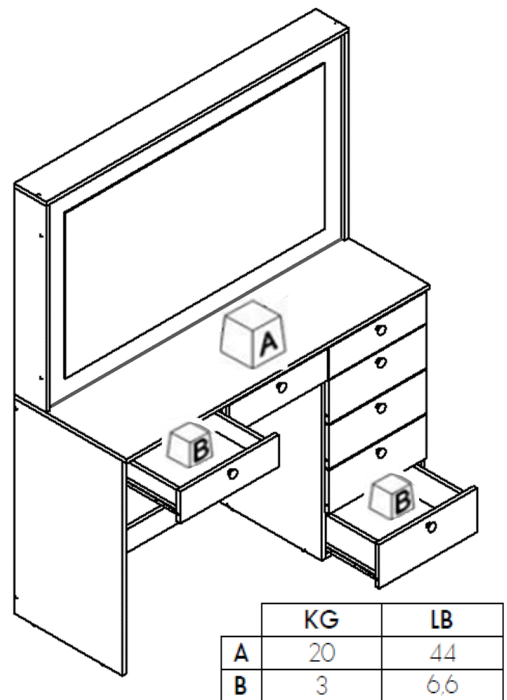

Weight in pounds. / Peso en libras.

Note: weight must be evenly distributed.
 Nota: el peso debe estar distribuido uniformemente.

You will need / usted necesitará:

Tools not included / herramientas no incluidas

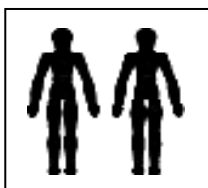

2 people
2 personas

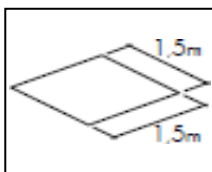

Recommended space for assemble
Espacio recomendado para el armado

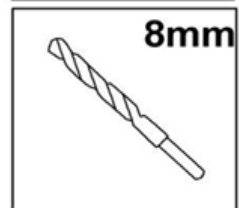
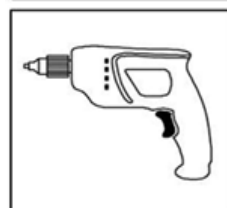
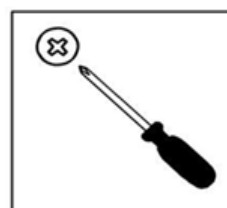

**Note: Place a carpet or blanket in the assembly area to avoid damage to the parts during the process.
 Nota: Colocar una alfombra o manta en el area de armado para evitar daños en las piezas durante el proceso.**

PARTS IDENTIFICATION / IDENTIFICACION DE PARTES



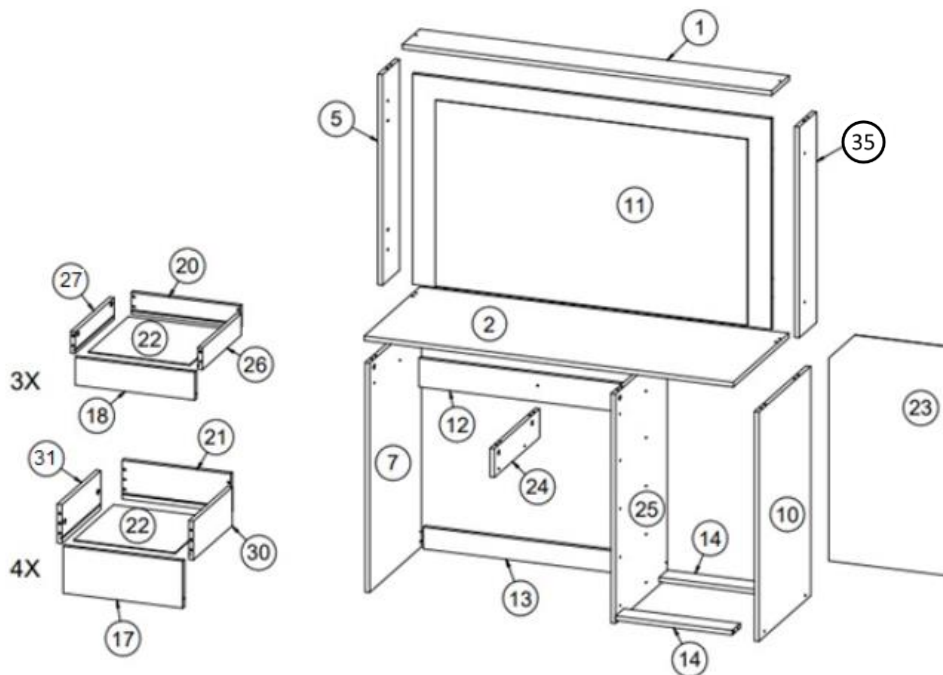







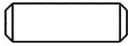
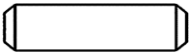

| Nº | DESCRIPTION - DESCRIPCIÓN | QTY. | BOX |
|----|--|------|-----|
| 1 | Top tray / Travesaño superior | 1 | 2/2 |
| 2 | Top base / Base superior | 1 | 2/2 |
| 5 | Left side tray / Travesaño lateral izquierdo | 1 | 1/2 |
| 7 | Left side / Lateral izquierdo | 1 | 1/2 |
| 10 | Right side / Lateral derecho | 1 | 1/2 |
| 11 | Mirror / Espejo | 1 | 2/2 |
| 12 | Crossbeam / Travesaño | 1 | 1/2 |
| 13 | Large footer / Zócalo grande | 1 | 1/2 |
| 14 | Small footer / Zócalo pequeño | 2 | 1/2 |
| 17 | Front of large drawer / Frontal de cajón grande | 4 | 1/2 |
| 18 | Front of small drawer / Frontal de cajón pequeño | 3 | 2/2 |
| 20 | Rear of small drawer / Posterior de cajón pequeño | 3 | 1/2 |
| 21 | Rear of large drawer / Posterior de cajón grande | 4 | 1/2 |
| 22 | Bottom of drawer / Fondo de cajón | 7 | 1/2 |
| 23 | Backboard / Fondo | 1 | 1/2 |
| 24 | Drawer divide support / Divisoria soporte cajón | 1 | 1/2 |
| 25 | Division / División | 1 | 1/2 |
| 26 | Side of the small right drawer / Lateral de cajón pequeño derecha | 3 | 1/2 |
| 27 | Side of the small left drawer / Lateral de cajón pequeño izquierda | 3 | 1/2 |
| 30 | Right side of large drawer / Lateral derecho de cajón grande | 4 | 1/2 |
| 31 | Left side of large drawer / Lateral izquierdo de cajón grande | 4 | 1/2 |
| 35 | Right side tray / Travesaño lateral derecho | 1 | 1/2 |

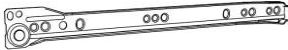

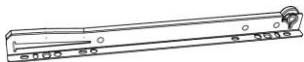

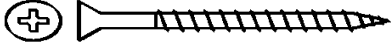
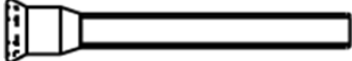
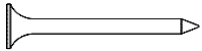

IDENTIFICATION OF ACCESSORIES / IDENTIFICACION DE ACCESORIOS

Note: the separation of the accessories before starting the assembly will facilitate it.

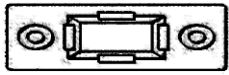
Nota: la separación de los accesorios antes de empezar el armado facilitará el mismo.

| NUMBER | | DESCRIPTION | QTY |
|--------|---|---|-----|
| A |  | Wooden dowel / Pin (6 x 30 mm) | 64 |
| AS |  | Wooden dowel / Pin (6 x 50 mm) | 2 |
| AZ |  | Allen key / Llave allen | 1 |
| B |  | Simple minifix screw / Tornillo minifix simple | 22 |
| C |  | Drum lock / Tambor minifix | 22 |
| G |  | Pan head screw / Tornillo cabeza olla (4,0 x 30 mm) | 7 |
| CR1 |  | Metallic left slide 350mm / corredera lateral izquierda 350mm | 7 |
| CR2 |  | Metallic right slide 350 mm / Corredera lateral derecha 350mm | 7 |
| CR3 |  | Left drawer slide 350mm / Corredera cajón izquierda 350mm | 7 |
| CR4 |  | Right drawer slide 350 mm / Corredera cajón derecha 350 mm | 7 |
| D |  | Flat head screw / Tornillo cabeza plana (3,5 x 14 mm) | 64 |
| DE |  | Screw / Tornillo cabeza plana (4,5 x 50 mm) | 2 |
| DZ |  | Structural screw / Tornillo estructural (5 x 40 mm) | 31 |
| EN |  | Nail / Clavo | 23 |
| FM |  | Adhesive bore patch / Tapón adhesivo | 31 |
| L |  | Drywall Anchor / Anclaje de pared | 2 |
| PX |  | Knob / Tirador | 7 |
| Q |  | Plastic angle support / Soporte de plástico | 2 |

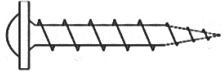
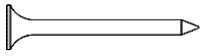
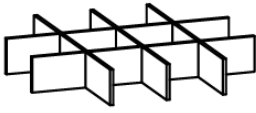
| | | | |
|----|---|---|----|
| V |  | Mounting bracket / Soporte de montaje | 2 |
| X |  | Small plastic foot / Pie plástico | 7 |
| Y |  | Adhesive bore patch / Tapón adhesivo | 14 |
| E |  | Clamp / Abrazadera | 1 |
| F |  | <u>Flanged</u> head screw / Tornillo cabeza flangeada (3,5 x 16 mm) | 2 |
| H |  | Nail / Clavo (12x12mm) | 7 |
| AG |  | Drawer Divider / Divisor de gaveta | 1 |



ATTENTION

To facilitate the assembly process, separate and organize all boards before you start.

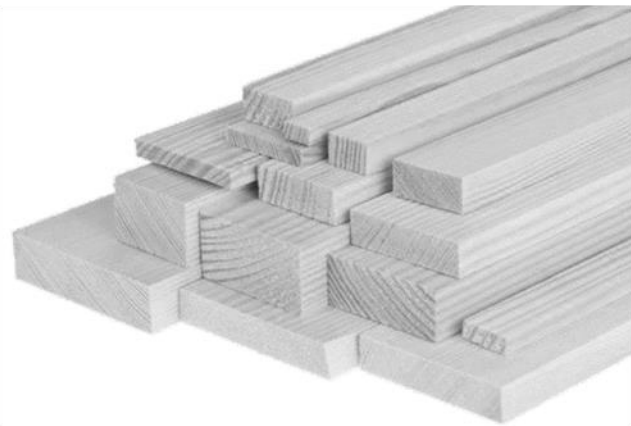

Para facilitar el armado, separa y organiza todas las tablas antes de empezar.

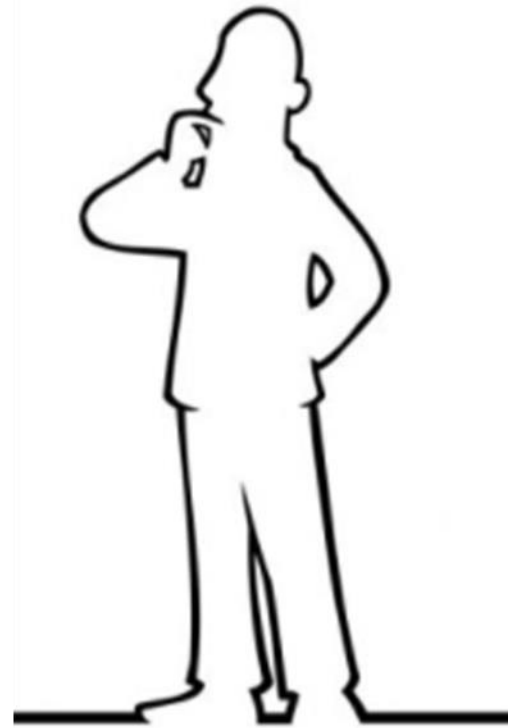

PRE-ASSEMBLY / PRE- ARMADO

1 Fix *wooden dowel* (A) to *crossbeam* (12) and *large footer* (13).
 Fijar pin (A) a *travesaño* (12) y *zócalo grande* (13).

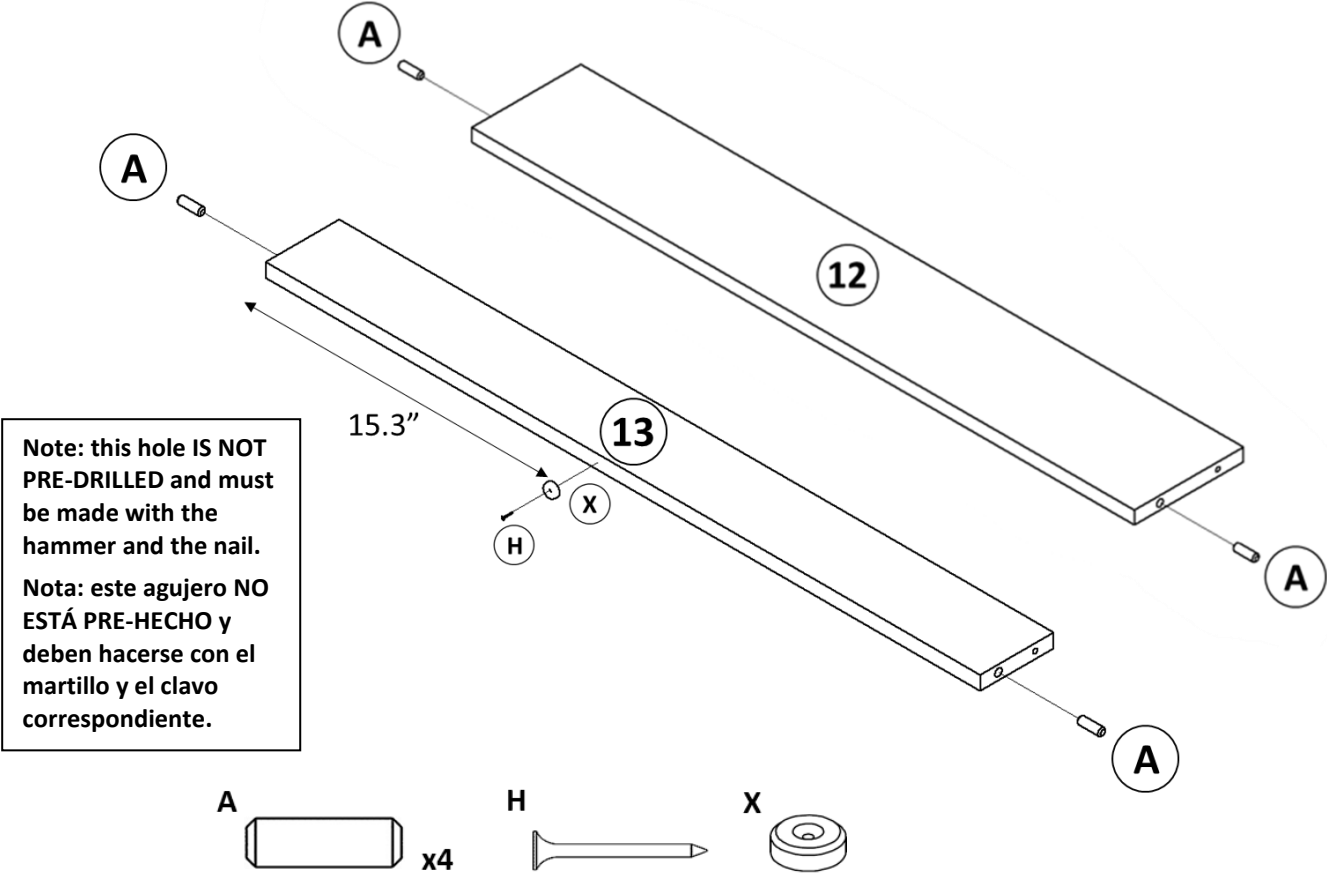

2 Fix *wooden dowel* (A) to *small footer* (14) x2.
 Fijar *pin* (A) a *zócalo pequeño* (14) x2.

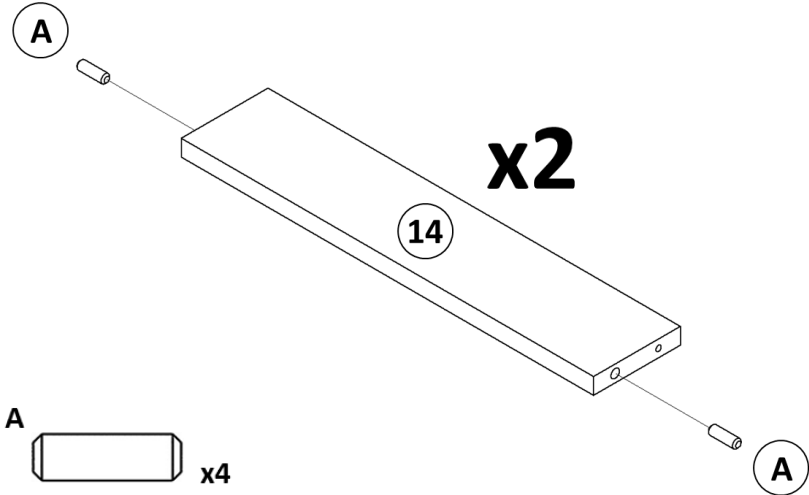

3

Fix **simple minifix screw** (B) to **top base** (2).
Fijar **tornillo minifix simple** (B) a **base superior** (2).

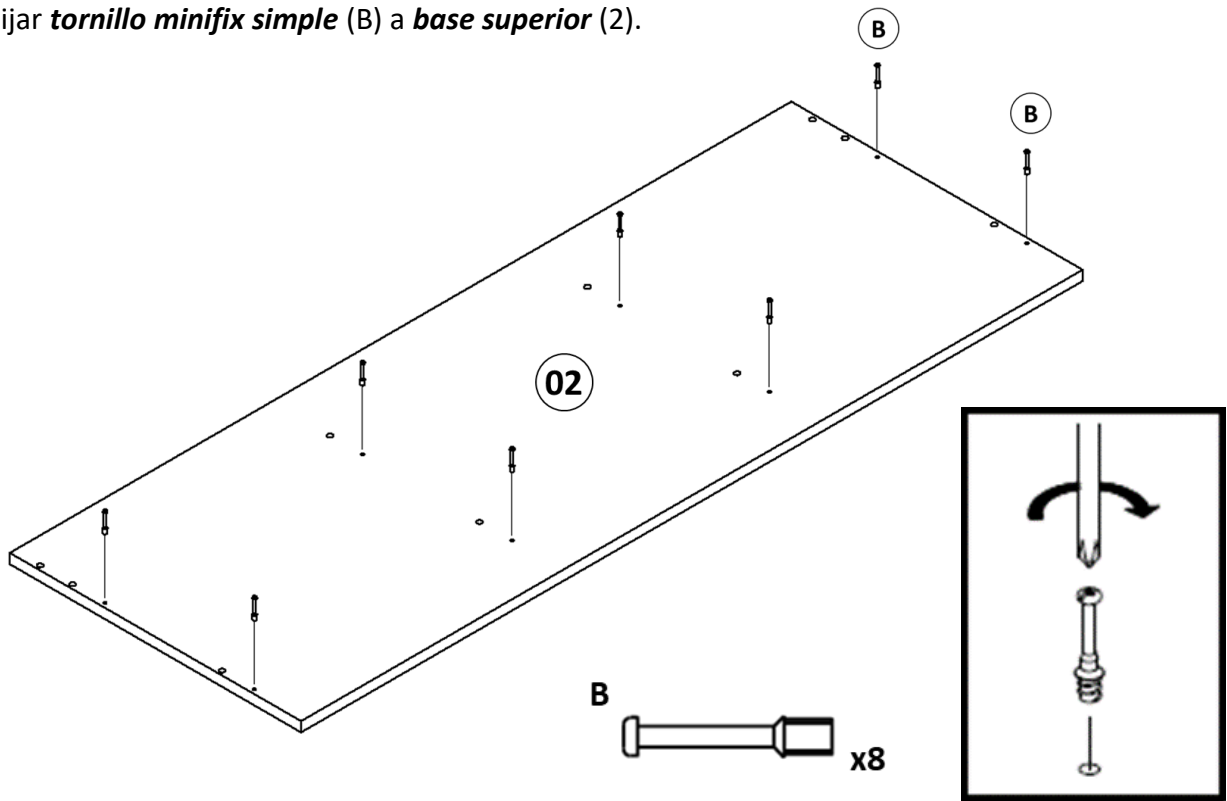

4

Fix **wooden dowel** (A), **metallic left slide** (CR1) and **plastic foot** (X) to **left side** (7).
Fijar **pin** (A), **corredera lateral izquierda** (CR1) y **pie plástico** (X) a **lateral izquierdo** (7).

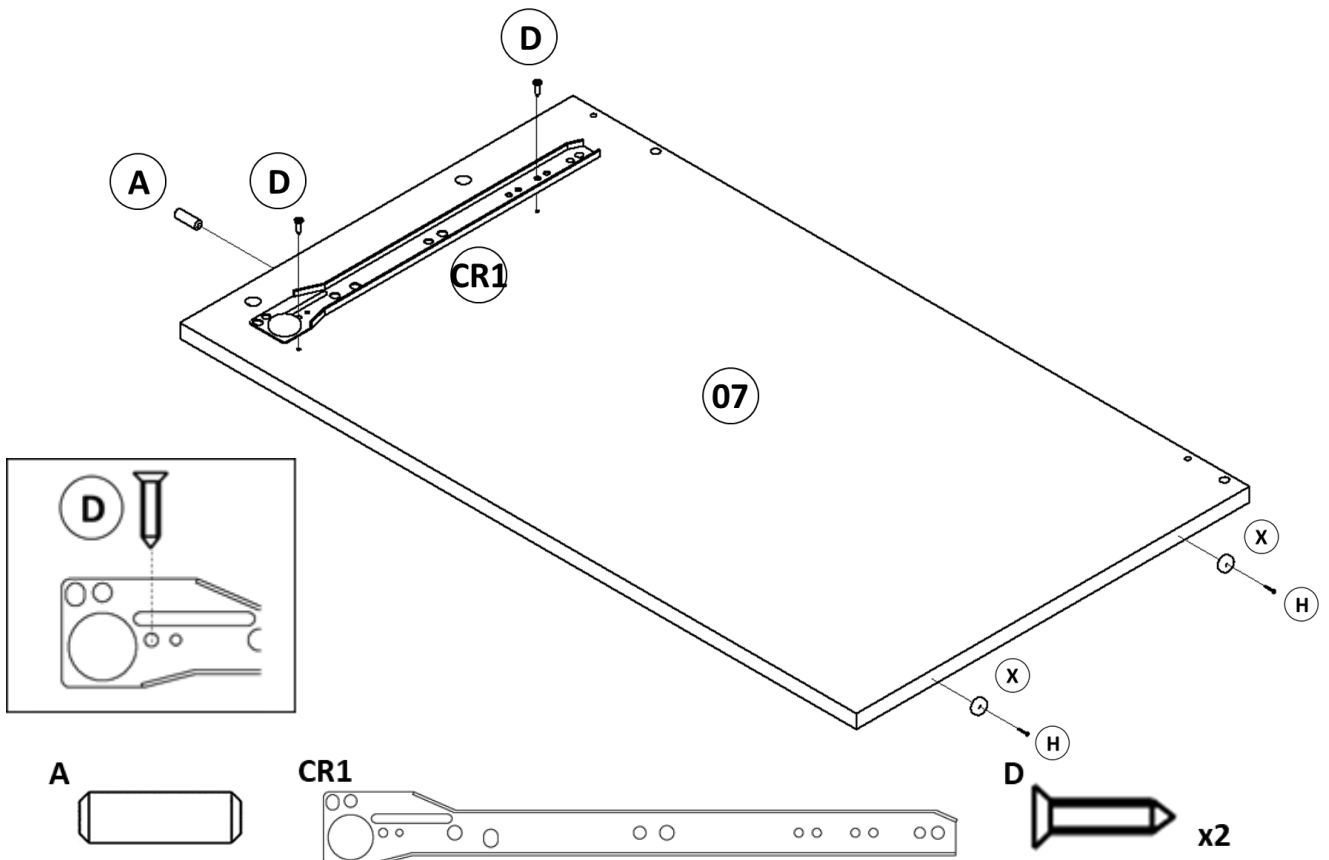

5

Fix **wooden dowel (A)** to **sides of drawer (30/31) x4** and **side drawer (26/27) x3**
Fije el **pin (A)** al **lateral del cajón grande (30/31) x4** y al **lateral del cajón pequeño (26/27) x3**

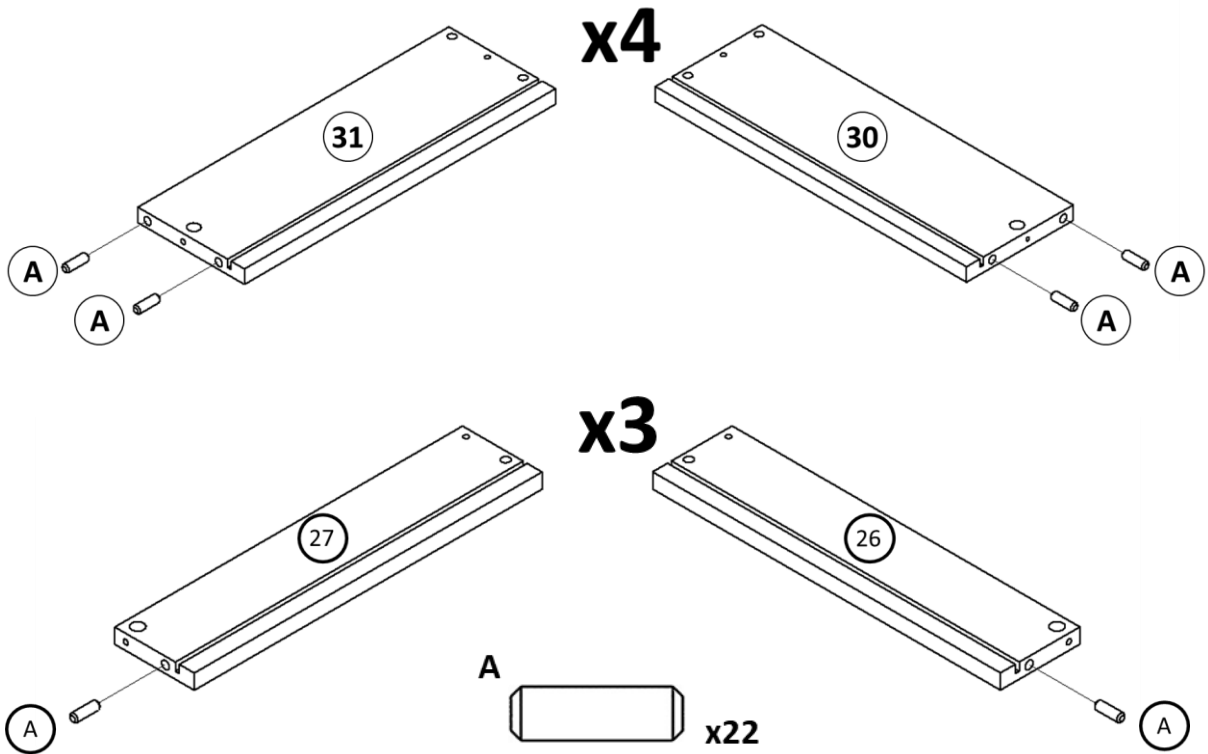

6

Fix **wooden dowel (A)** to **rear of large drawer (21)x4** and **rear of small drawer (20)x3**
Fije el **pin (A)** al **posterior de cajón grande (21)x4** y al **posterior de cajón pequeño (20)x3**

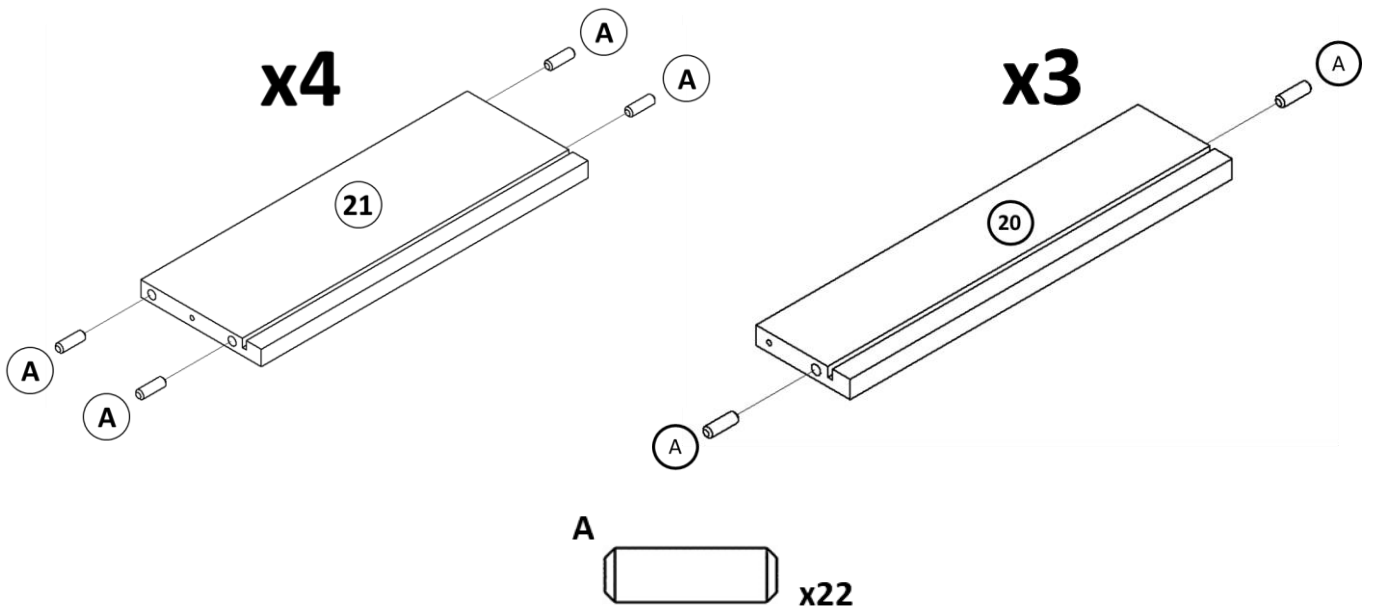

7

Fix **simple minifix screw (B)** to **front of large drawer (17)** x4 and **front of small drawer (18)** x3.
 Fijar **tornillo minifix simple (B)** a **frente de cajón grande (17)** x4 y **frente de cajón pequeño (18)** x3

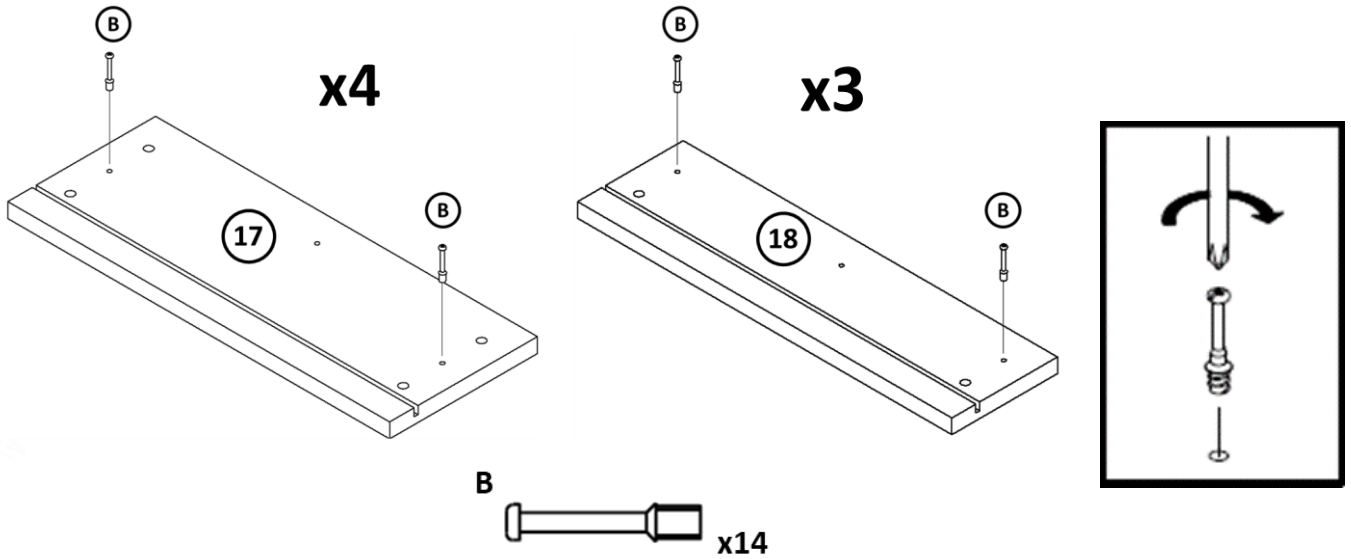

8

Fix **wooden dowel (A)**, **metallic right slide (CR2)** to **drawer divide support (24)**. Flip **drawer divide support (24)** and fix **metallic left slide (CR1)**.
 Fijar **pin (A)**, **corredera lateral derecha (CR2)** a **divisoria soporte cajón (24)**. Voltear **divisoria soporte cajón (24)** y fijar **corredera lateral izquierda (CR1)**.

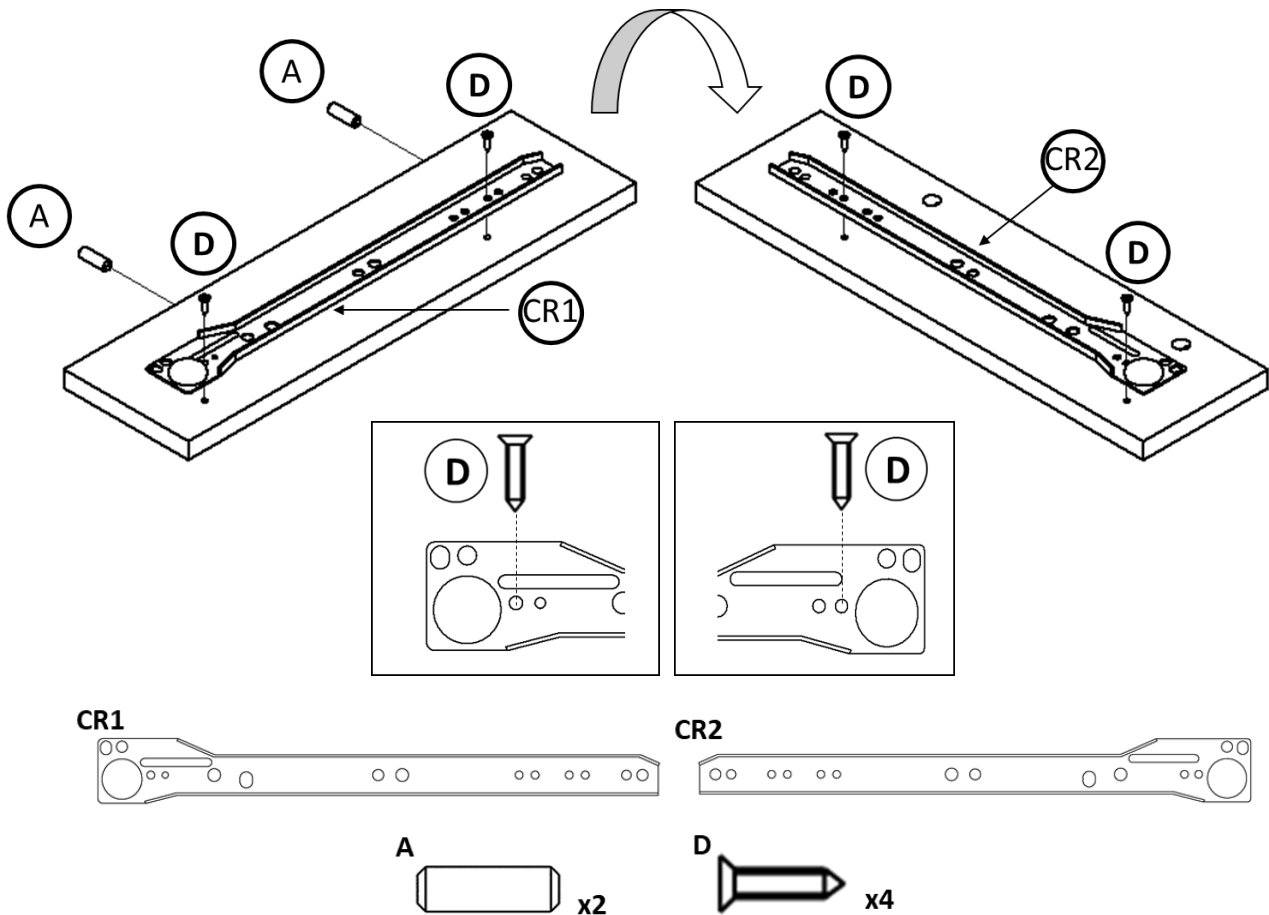

9 Fix **wooden dowel (A)** to left **side tray (5)** and **right side tray (35)**.

Fijar **pin (A)** a **travesaño lateral izquierdo (5)** y **travesaño lateral derecho (35)**.

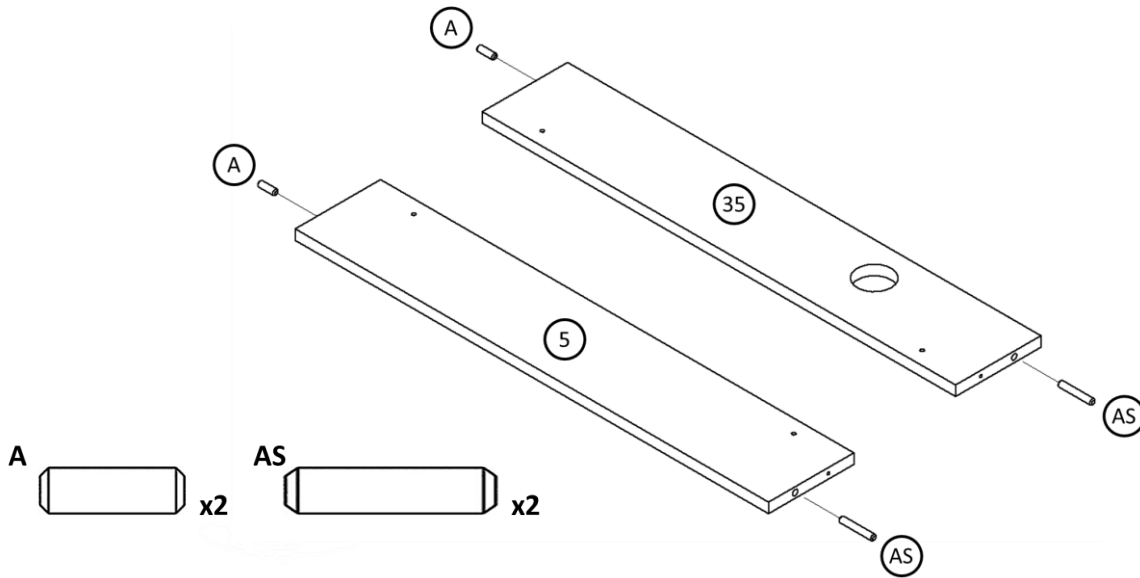

10 Fix **wooden dowel (A)**, **metallic right slide (CR2)** and **plastic foot (X)** to **right side (10)**.
Fijar **pin (A)**, **corredera lateral derecha (CR2)** y **pie plástico (X)** a **lateral derecho (10)**.

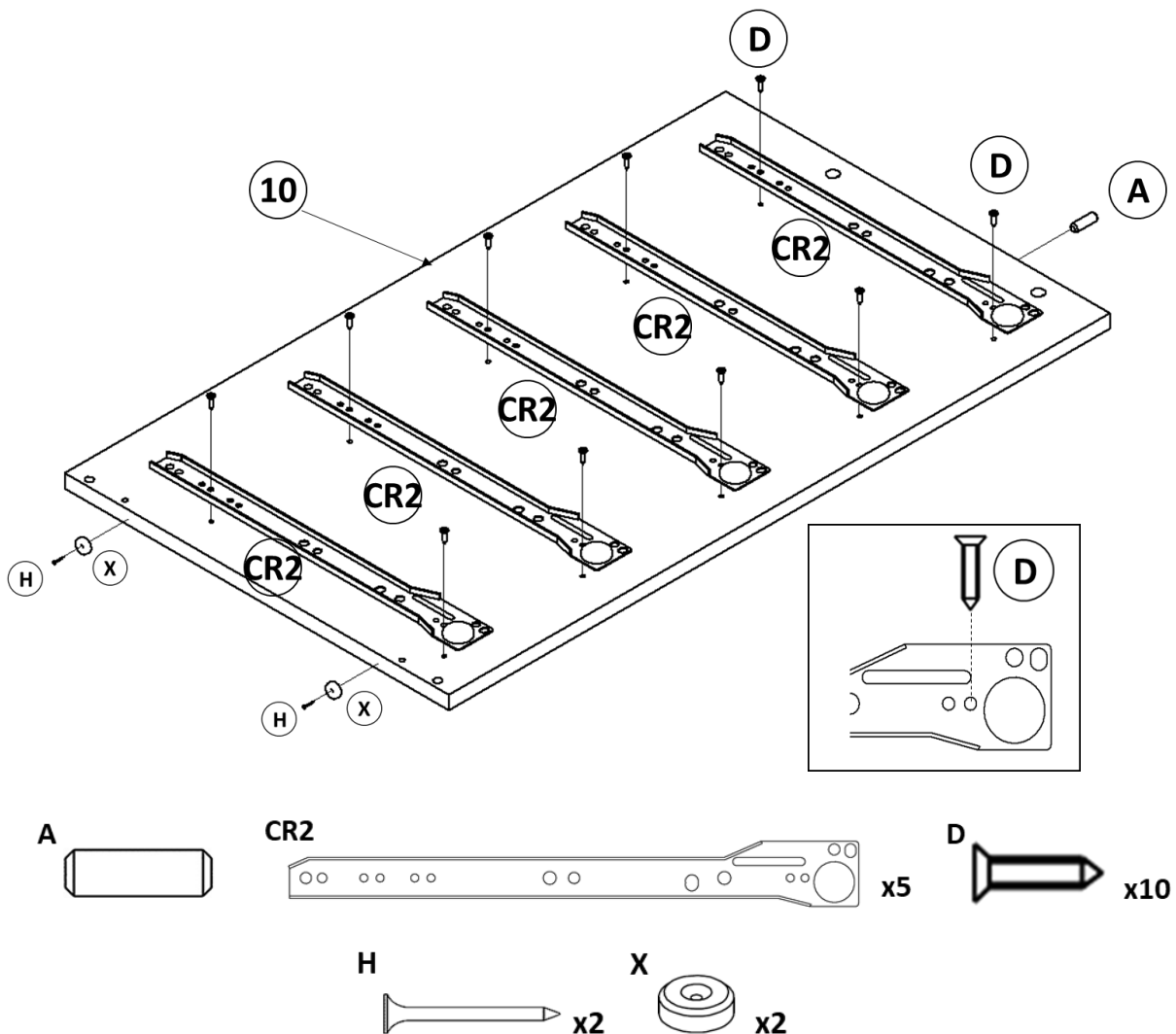

11 Fix **wooden dowel (A)**, **metallic left slide (CR1)** to **division (25)**. Flip **division (25)** and fix **metallic right slide (CR2)** and **plastic foot (X)**.

Fijar **pin (A)**, **corredera lateral izquierda (CR1)** a **división (25)**. Voltear **división (25)** y fijar **corredera lateral derecha (CR2)** y **pie plástico (X)**.

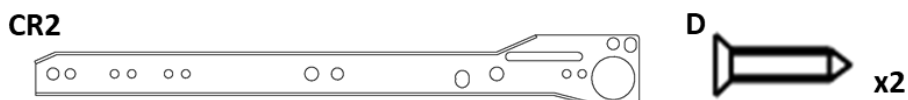
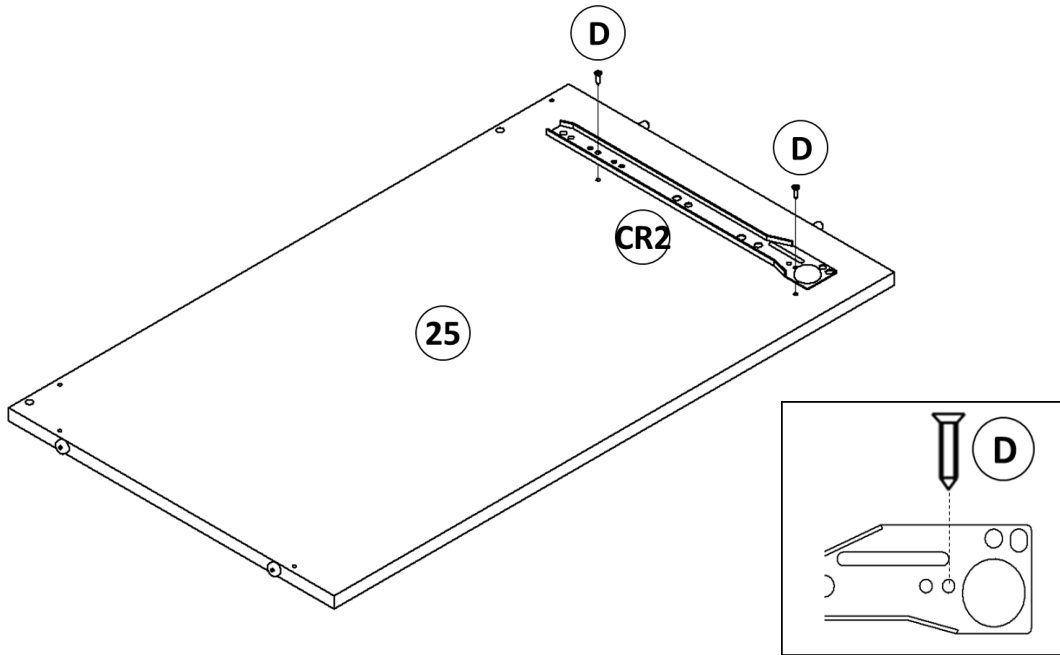
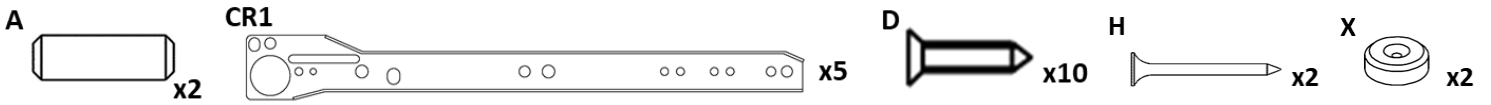
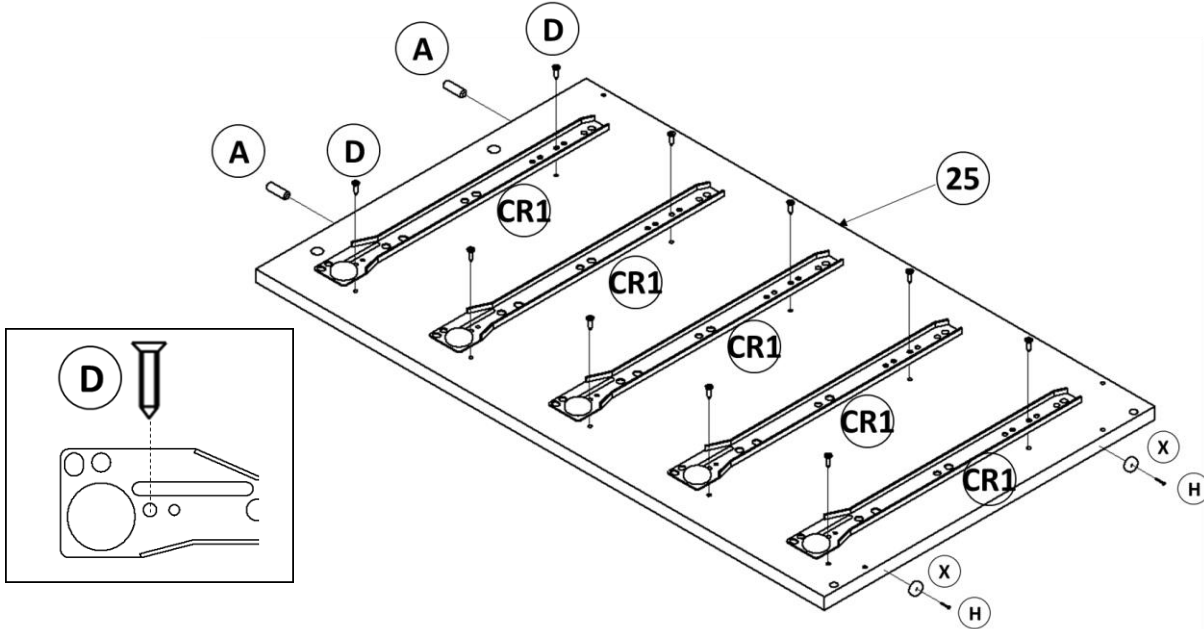

12 Fix *wooden dowel* (A) and *mirror support*.
Fijar *pin de madera* (A) y *soporte espejo*

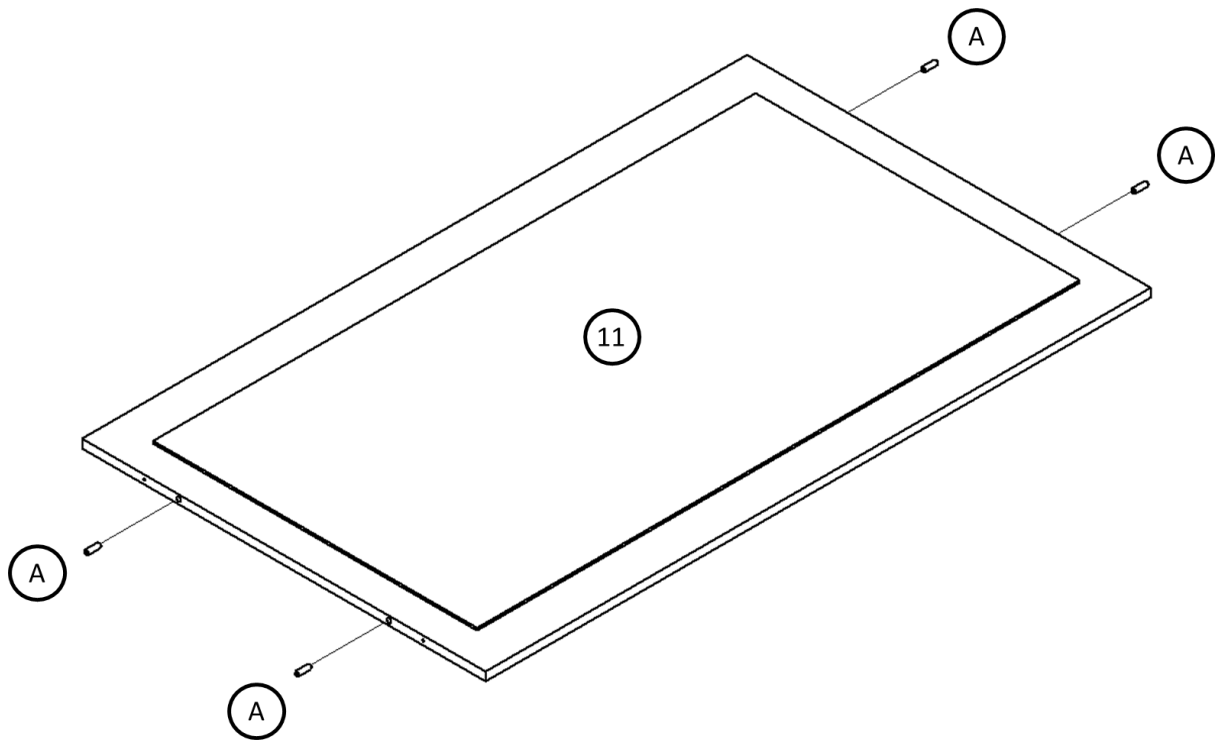

ASSEMBLY / ARMADO

- 13** Fix left *side tray* (5) and *right-side tray* (35) to *mirror* (11).
Fijar *travesaños laterales* (5) y (35) a *espejo* (11).

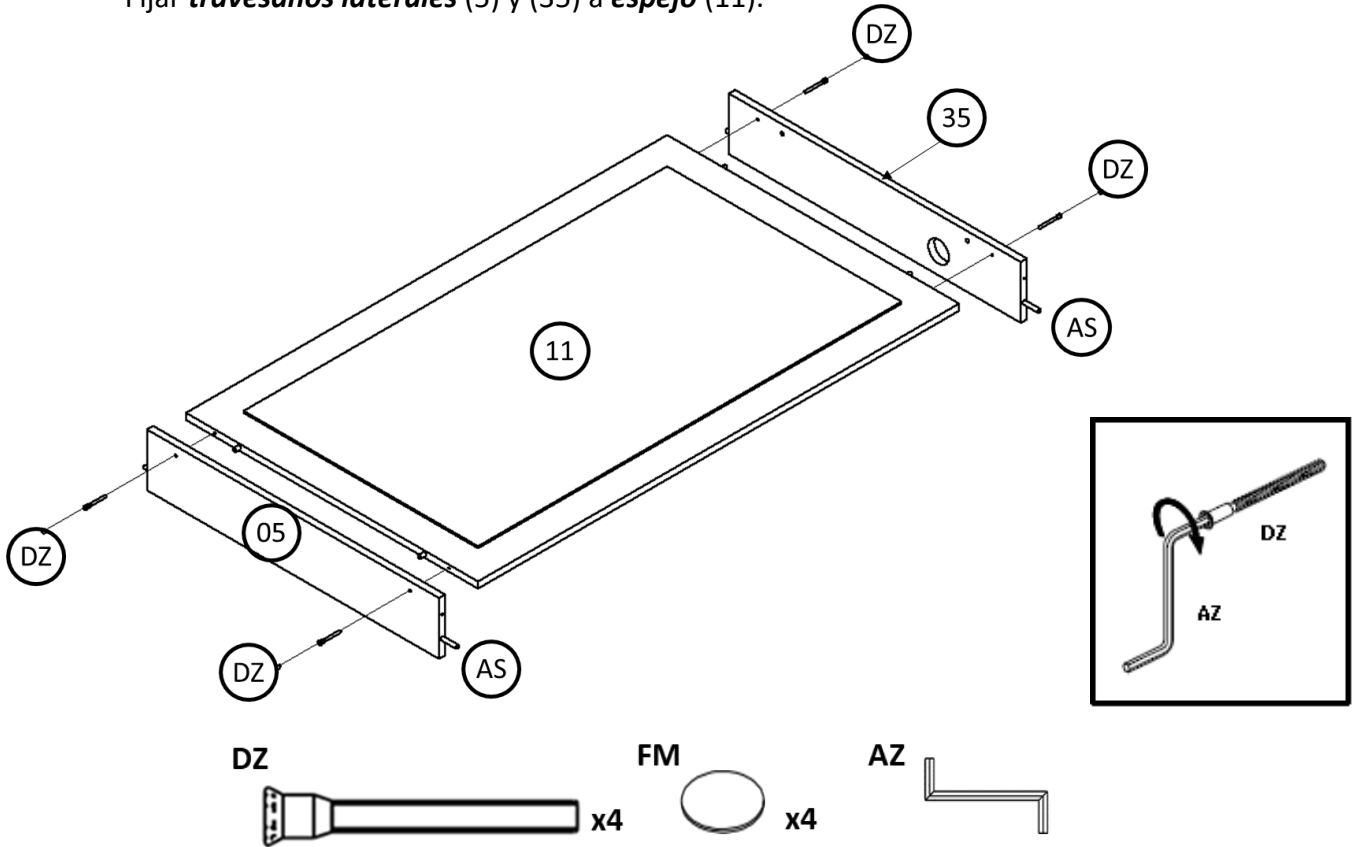

- 14** Fix *top tray* (1) to previous assembly.
Fijar *travesaño superior* (1) a ensamble previo.

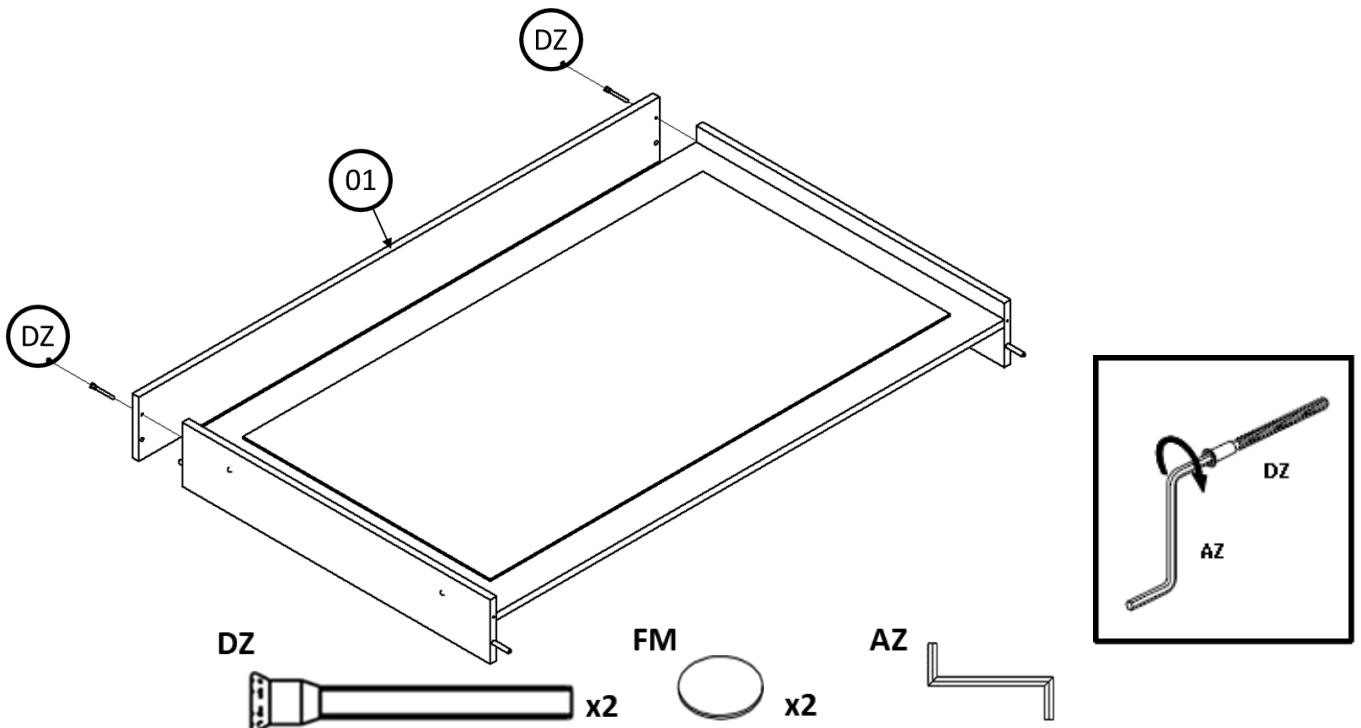

15 Fix *top base* (2) and to previous assembly.
Fijar *base superior* (2) a ensamble previo.

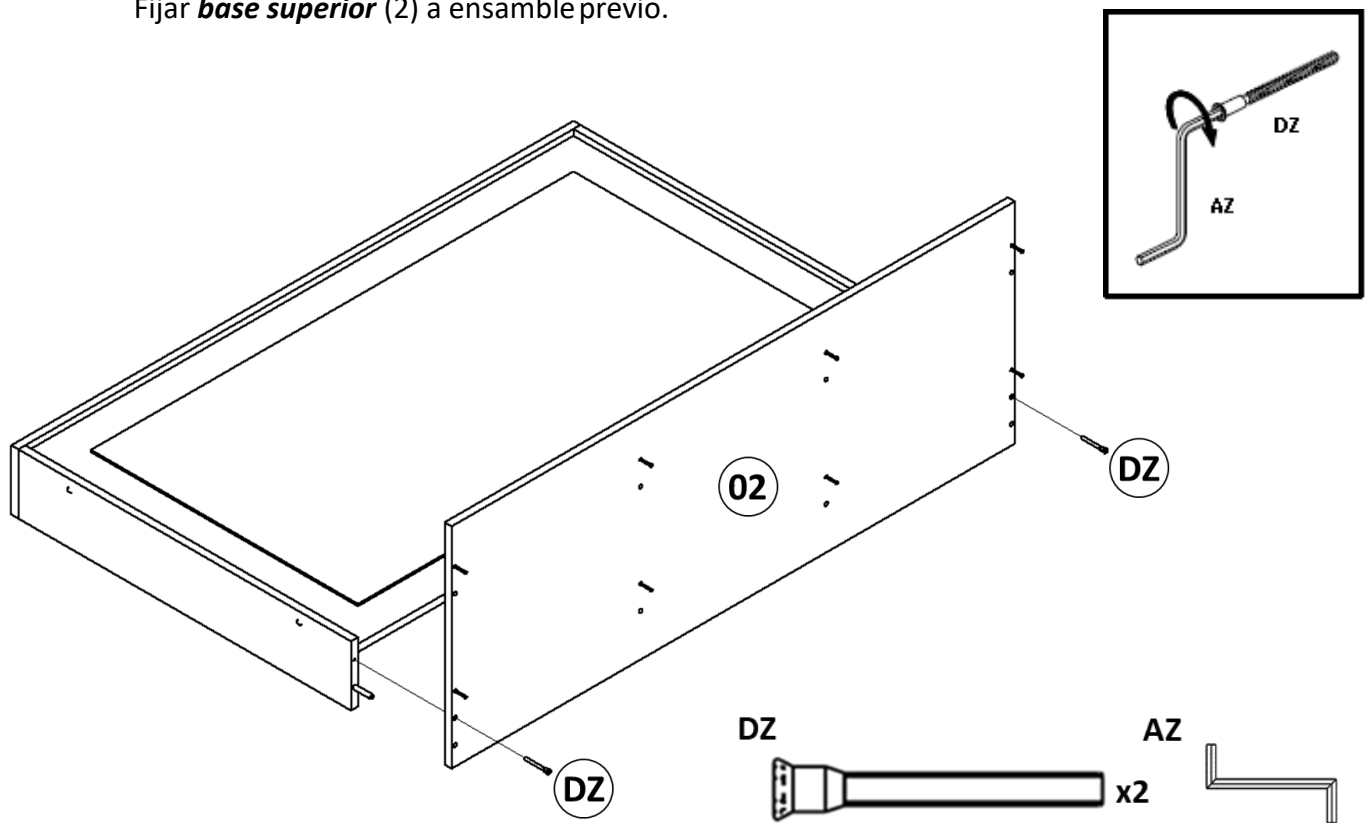

16 Fix *drawer divide support* (24) to previous assembly.
Fijar *divisoria soporte cajón* (24) a ensamble previo.

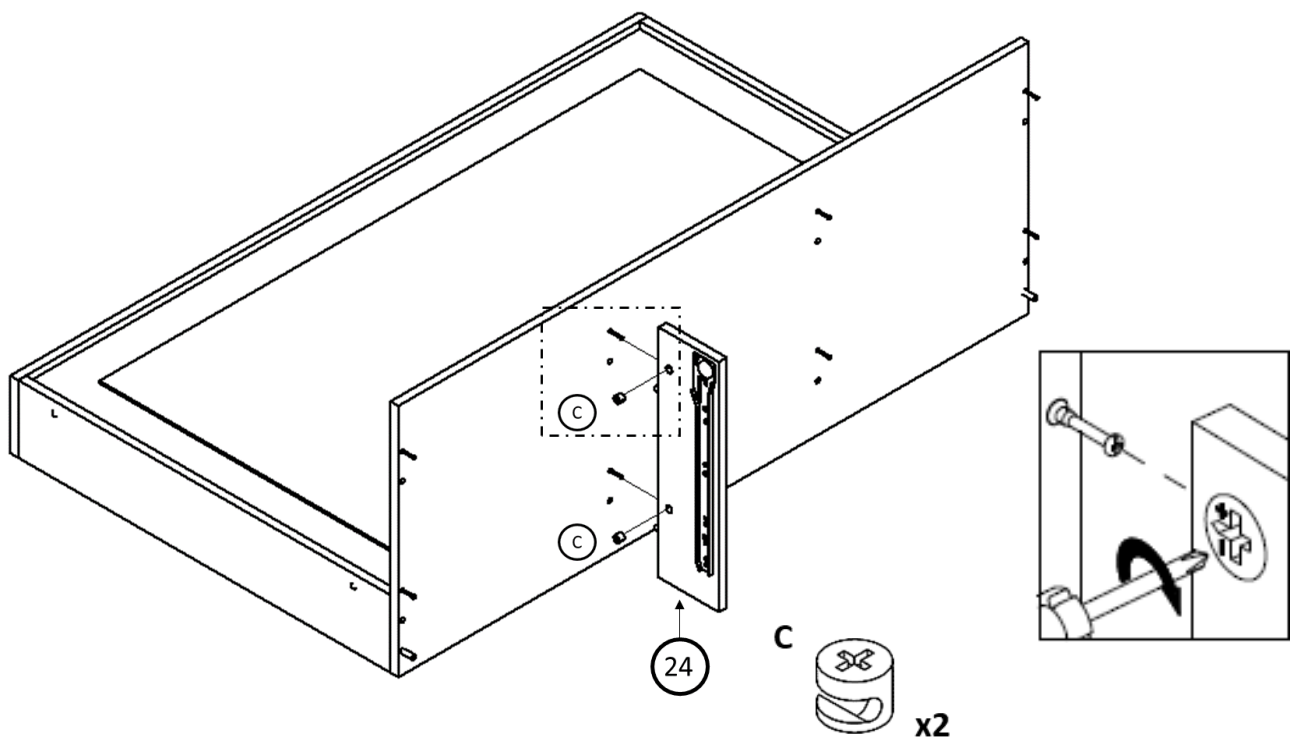

17

Fix **crossbeam** (12) and **large footer** (13) to **left side** (7) and **division** (25).
Fijar **travesaño** (12) y **zócalo grande** (13) a **lateral izquierdo** (7) y **división** (25).

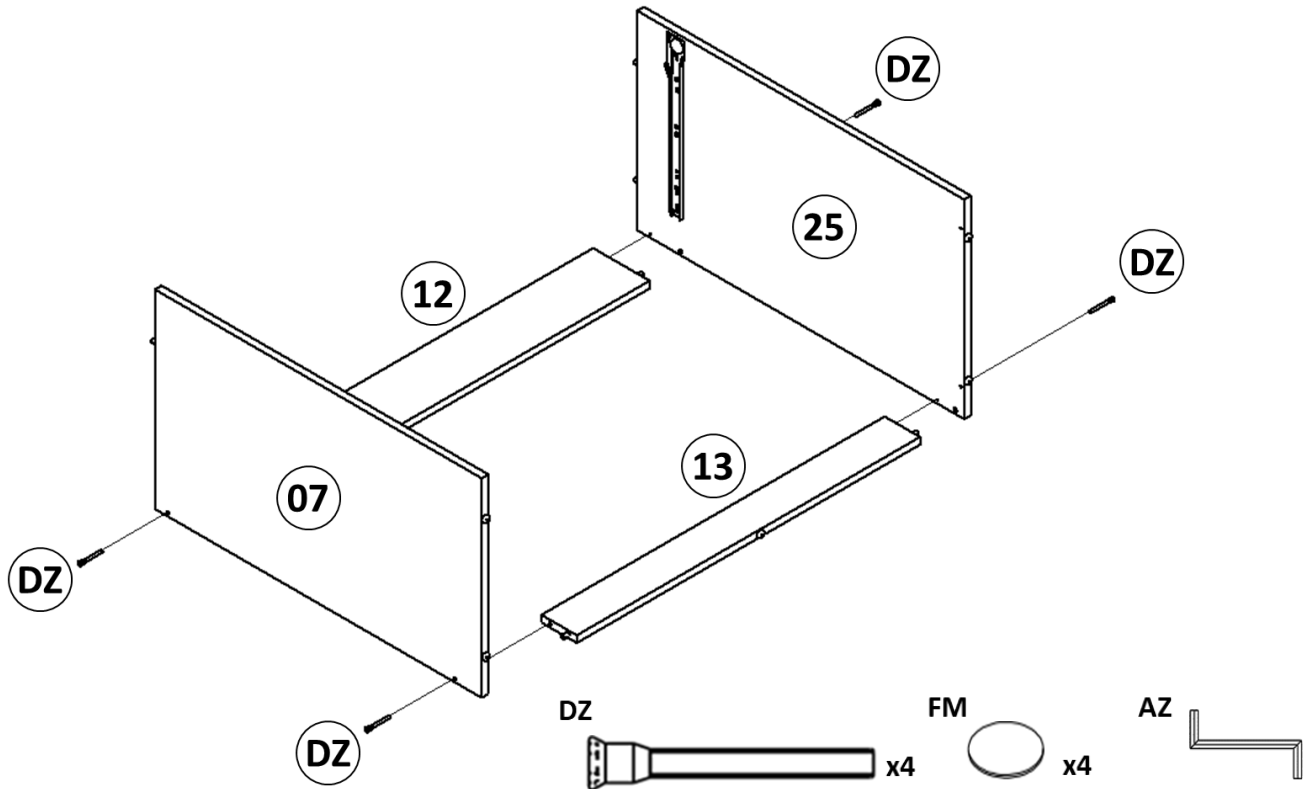

18

Fix **small footer** (14) x2 and **right side** (10) to previous assembly.
Fijar **zócalo pequeño** (14) x2 y **lateral derecho** (10) a ensamble previo.

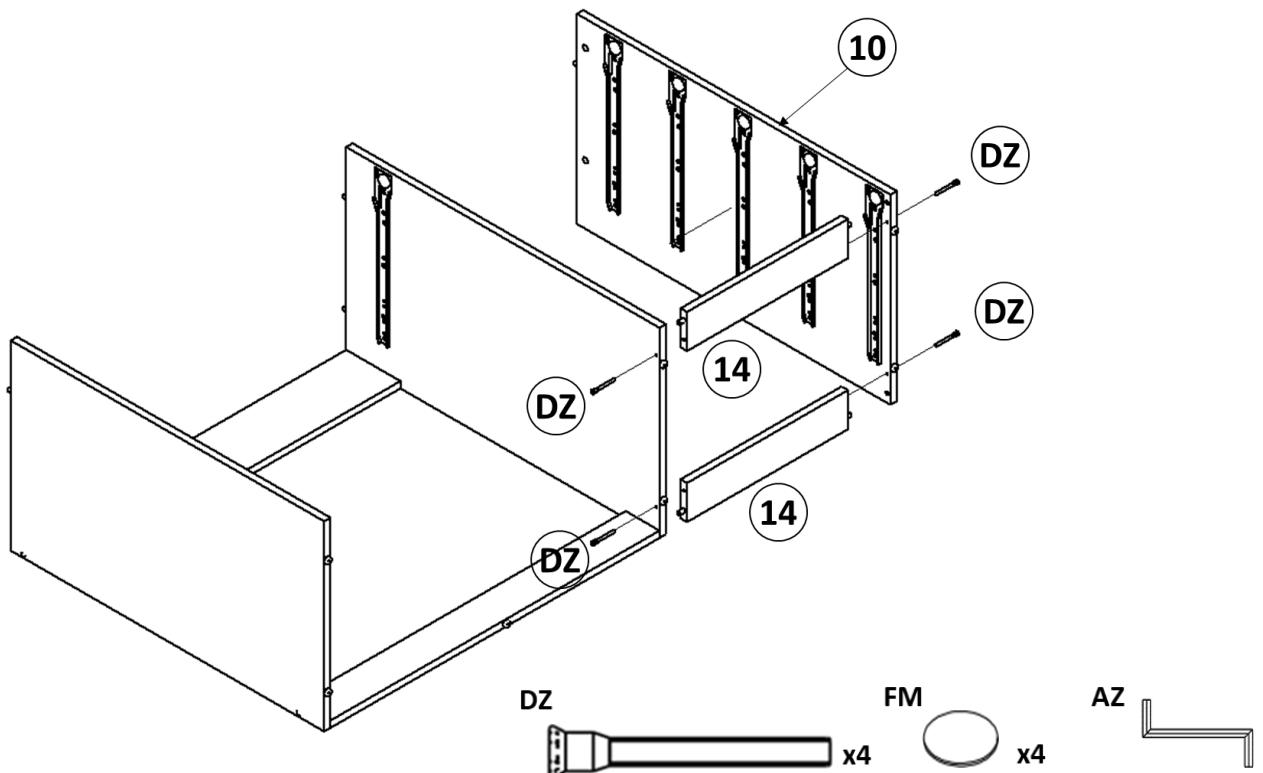

19

Fix both previous assemblies (16 and 18).

Fijar ambos ensambles previos (16 y 18).

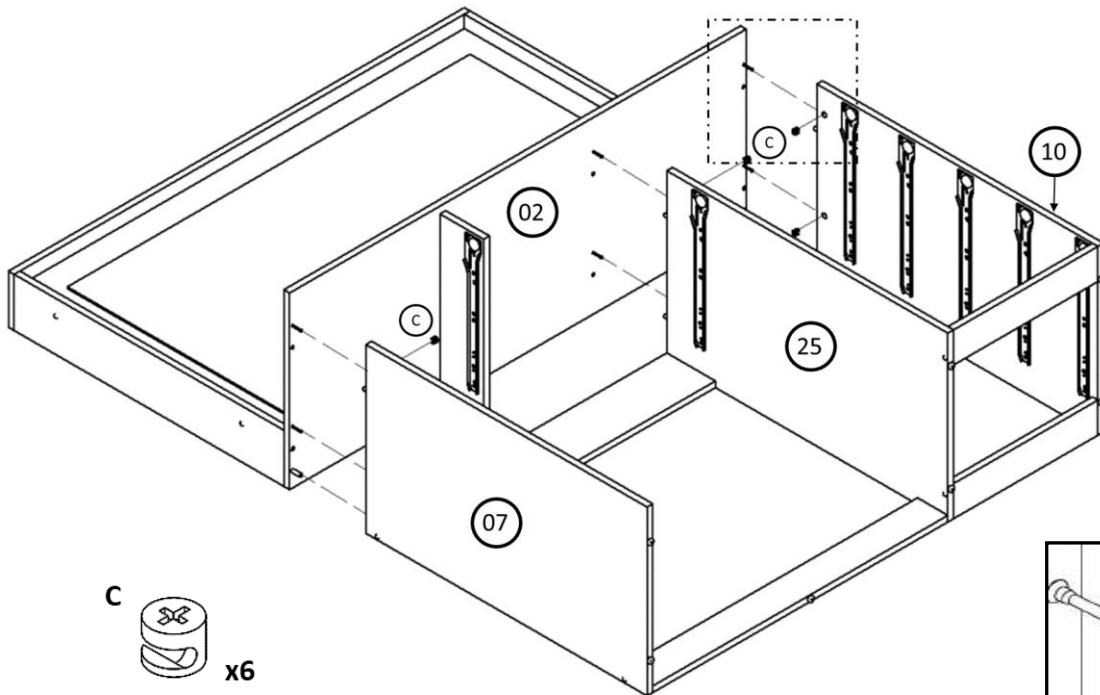

C  x6

20

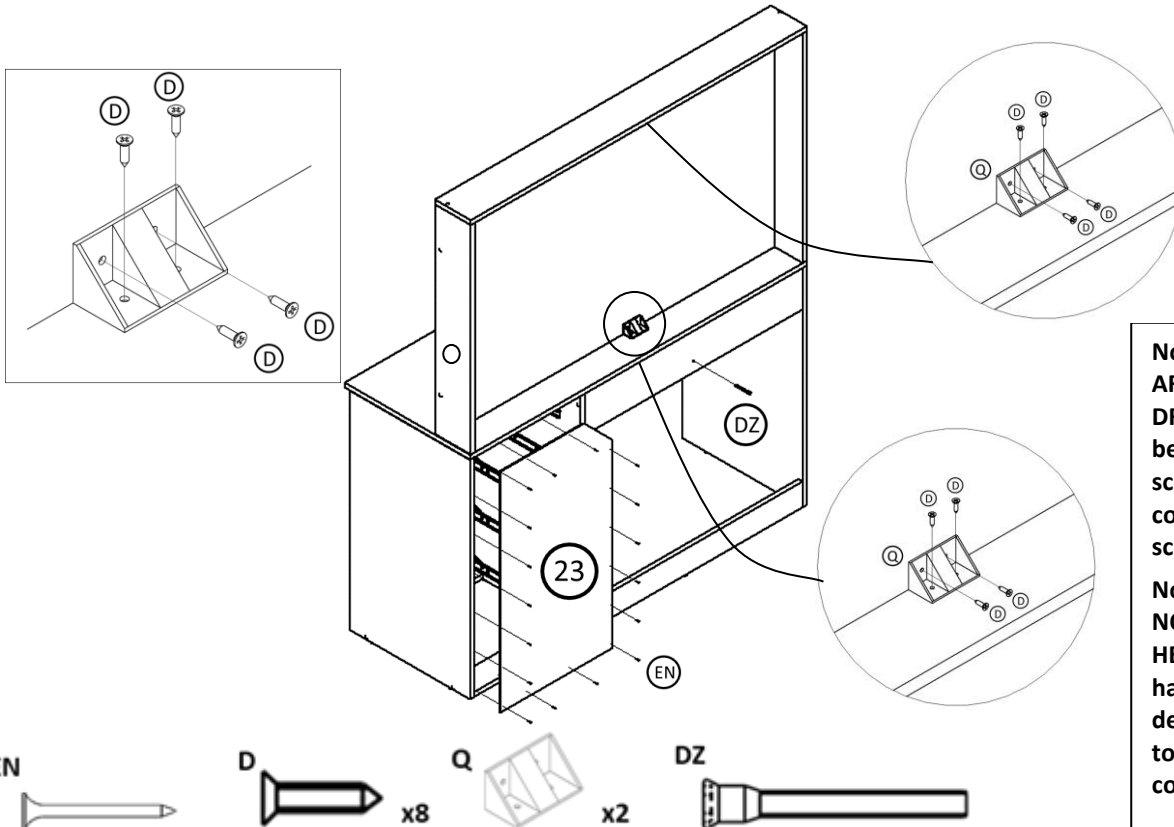

Fix **backboard** (23) and **plastic support** (Q) to previous assembly.

Fijar **fondo** (23) y **soporte plástico** (Q) a ensamble previo.



Note: these holes ARE NOT PRE-DRILLED and must be made with the screwdriver and the corresponding screw.

Nota: estos agujeros NO ESTAN PRE-HECHOS y deben hacerse con el destornillador y el tornillo correspondiente.

EN  D  x8 Q  x2 DZ 

21

Fix *side of drawer* (30/31) and *bottom of drawer* (22) to *rear of drawer* (21)
Fijar *lateral de cajón central* (30/31) y *fondo de cajón* (22) a *trasero de cajón* (21)

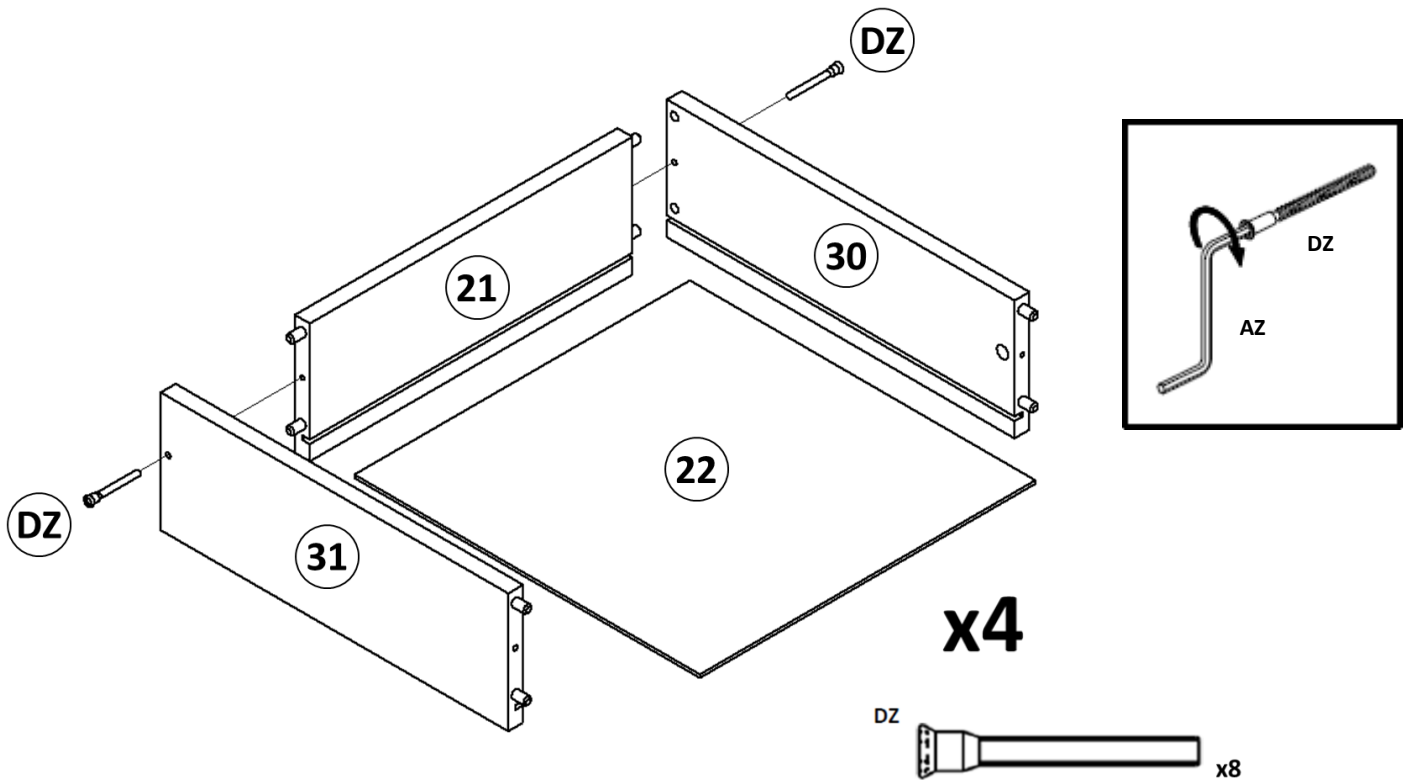

22

Fix *front large drawer* (17) x4 and *handle* (PX) x4 to previous assembly.
Fijar *frente del cajón grande* (17) x4 y *tirador* (PX) x4 a ensamble previo.

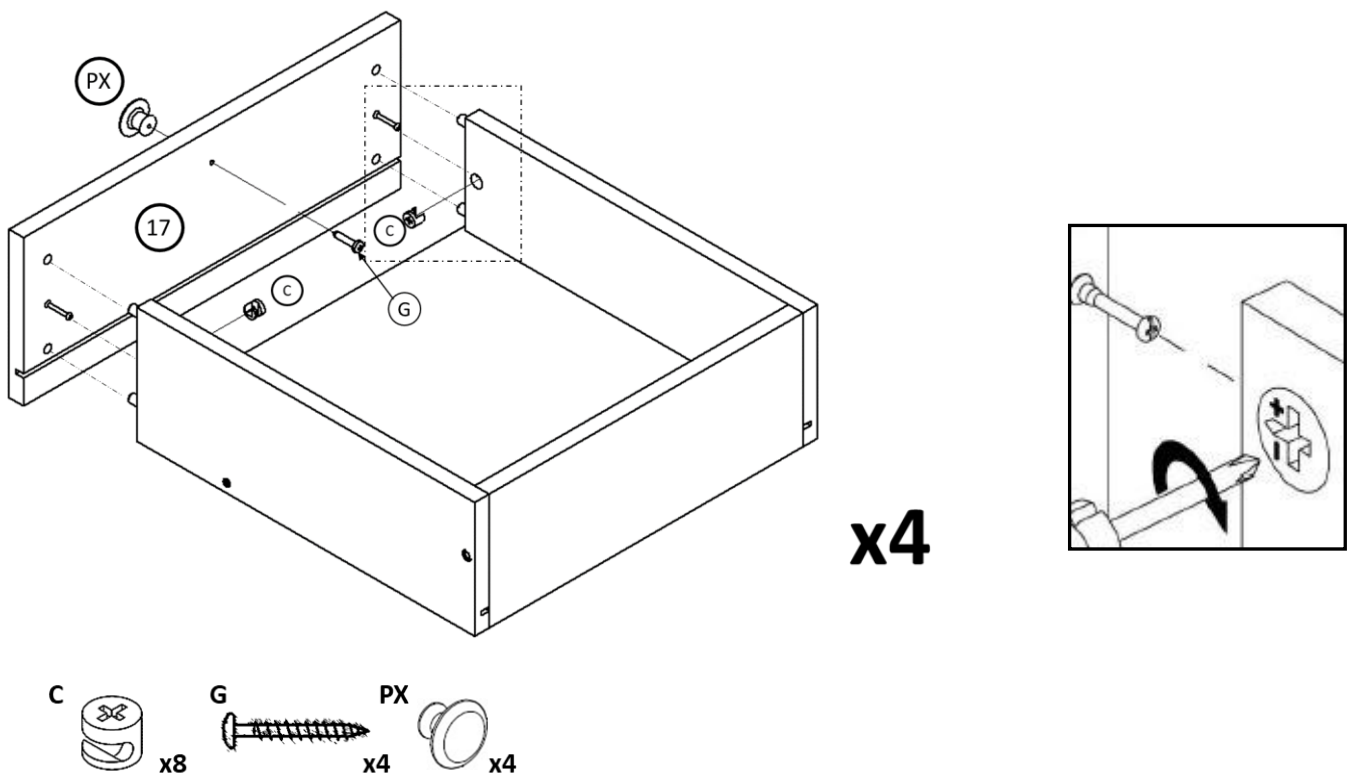

23

Fix **left drawer slide** (CR3) x4 and **right drawer slide** (CR4) x4 to large drawer x4.

Fijar **corredera de cajón izquierdo** (CR3) x4 y **corredera de cajón derecho** (CR4) x4 a cajón grande x4.

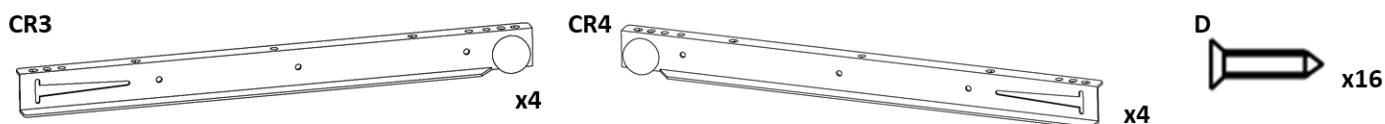
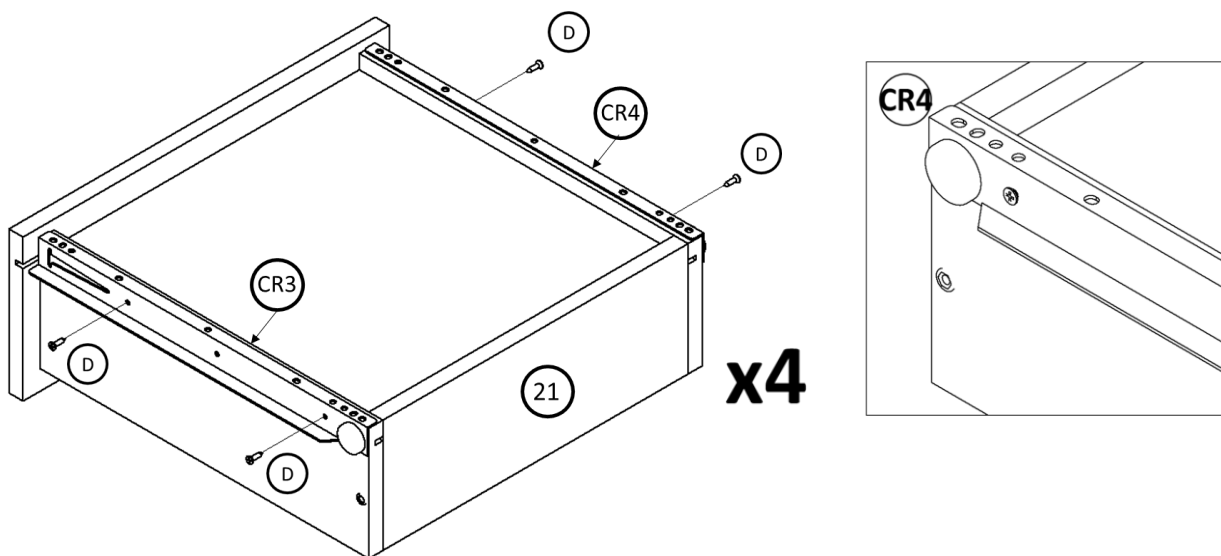

24

Attach the side of the **small drawer** (26/27) x6 to the **rear of the small drawer** (20) x3.

Coloque el lateral del **cajón pequeño** (26/27) x6 en la parte posterior del **cajón pequeño** (20)

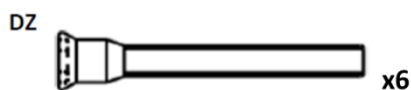
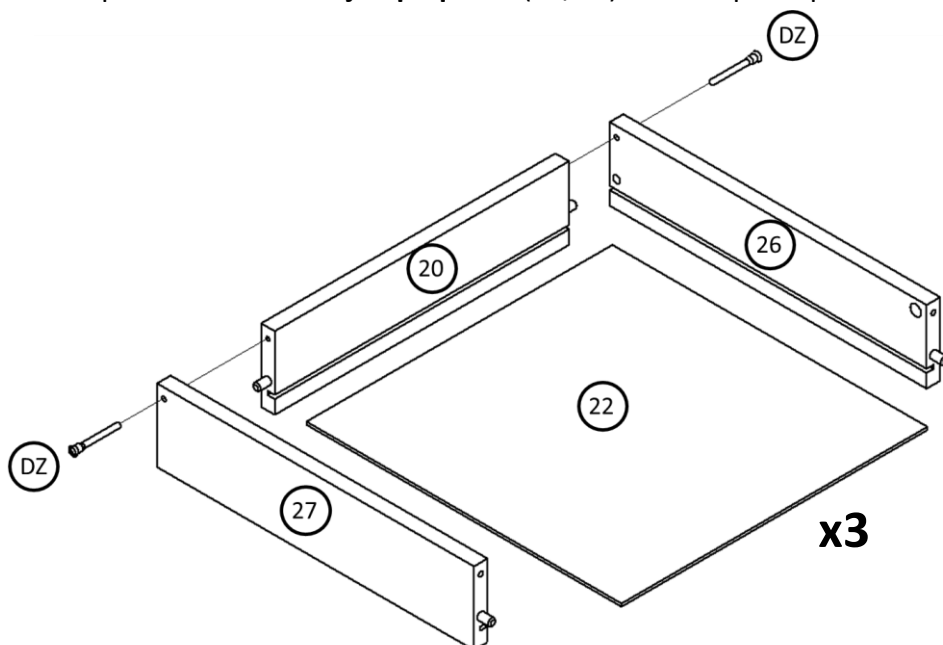

25

Fix **front of small drawer** (18) x3 and **handle** (PX) x3 to previous assembly.

Fijar **frente de cajón pequeño** (18) x3 y **tirador** (PX) x3 a ensamble previo.

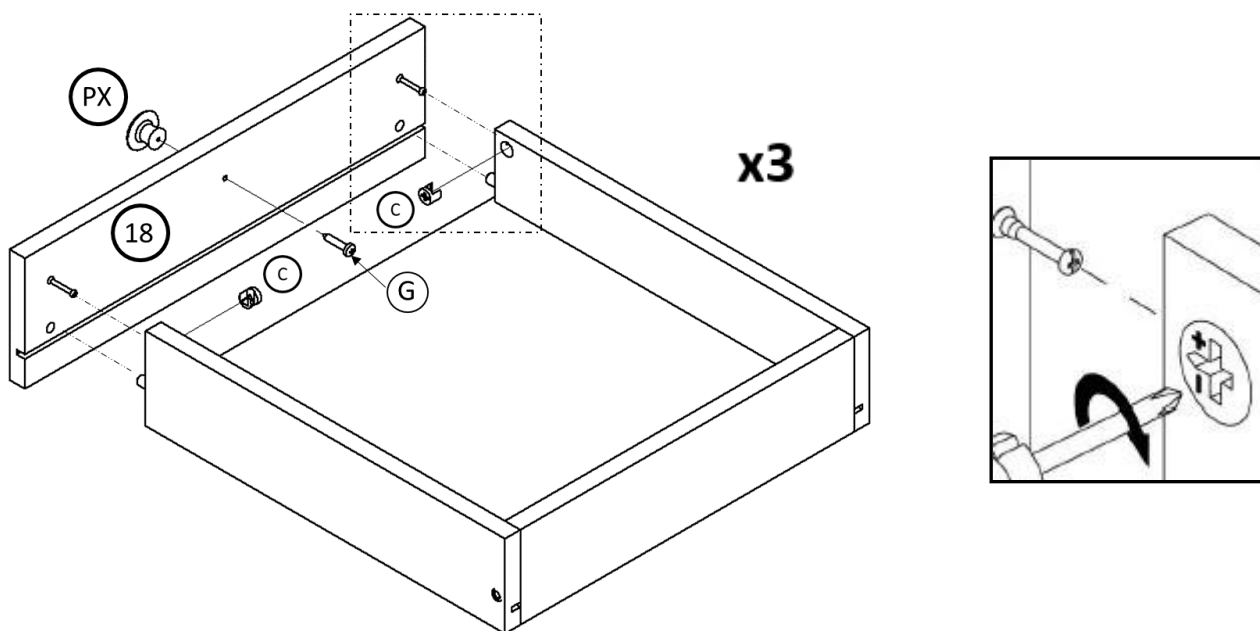

26

Fix **left drawer slide** (CR3) x3 and **right drawer slide** (CR4) x3 to small drawer x3.

Fijar **corredera de cajón izquierdo** (CR3) x3 y **corredera de cajón derecho** (CR4) x3 a cajón pequeño x3.

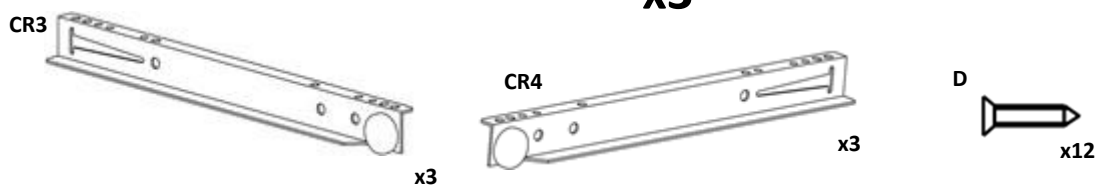
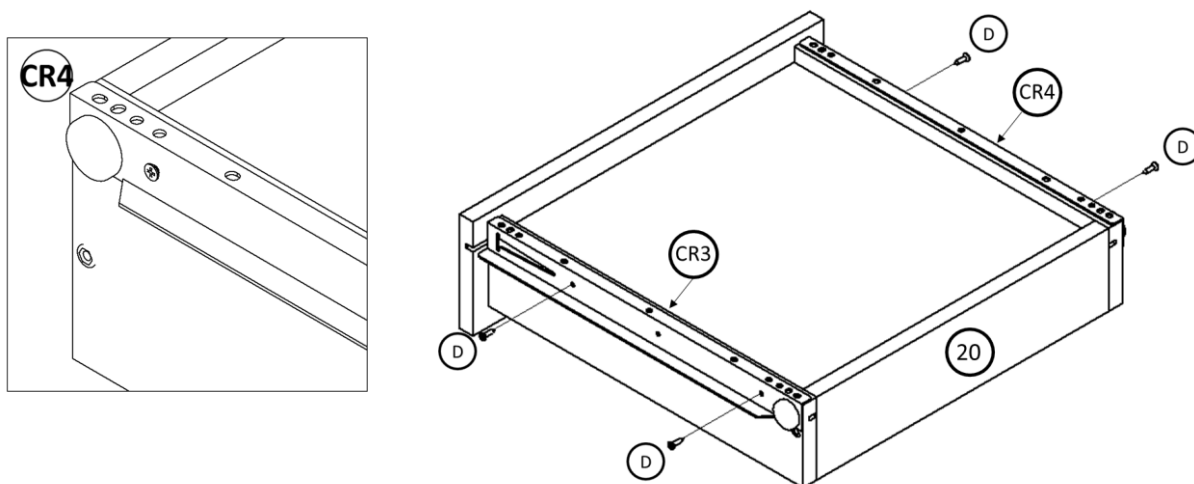

27

Place drawers.
Colocar cajones.

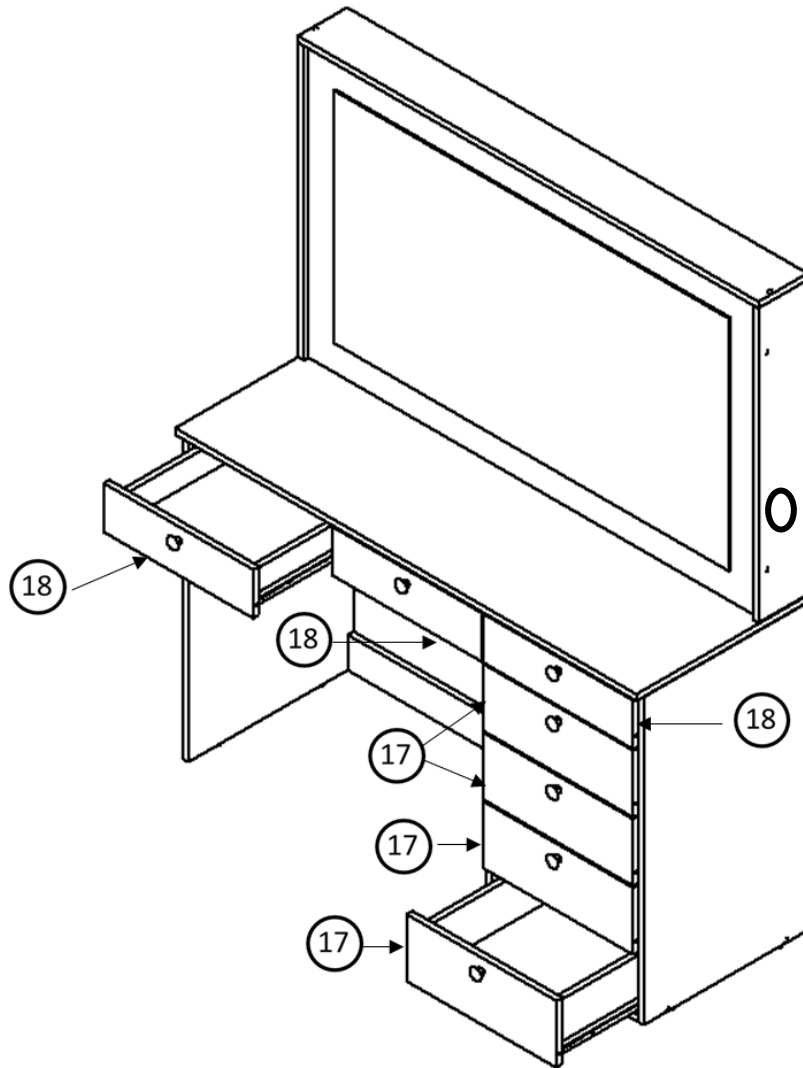

28

And finally fix furniture to the wall.

Y finalmente fijar mueble a la pared.

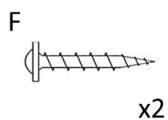
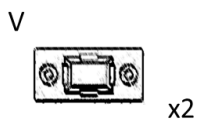
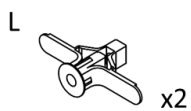
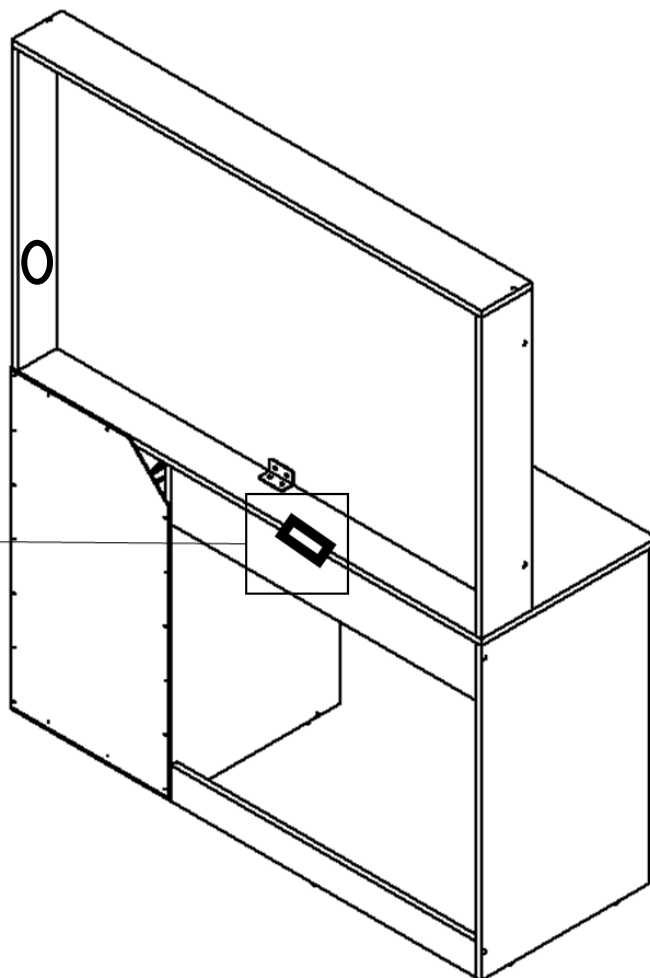
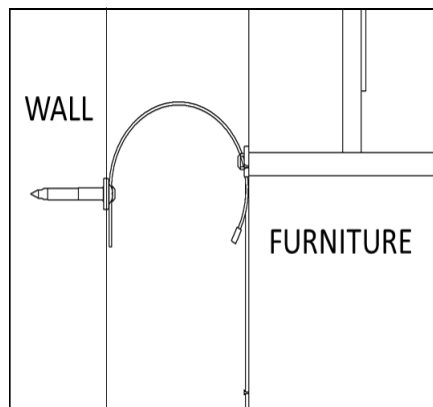
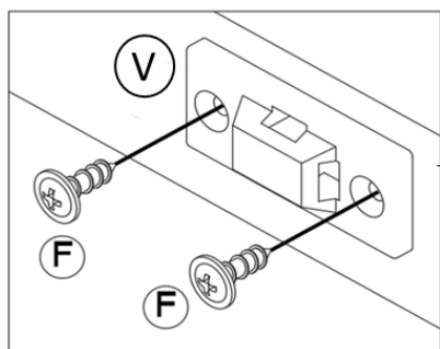
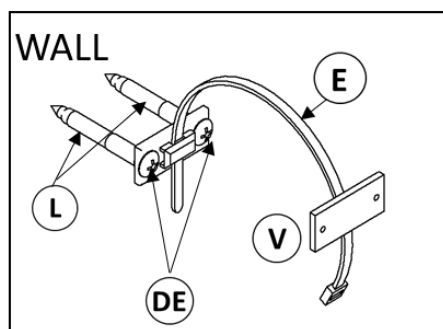

WARNING.

For security measures it is recommended to fix the furniture to the wall to avoid overturning of it, if this happens it can cause serious or fatal injuries.

ATENCIÓN.

Por medidas de seguridad se recomienda fijar el mueble a la pared para evitar volcamiento del mismo, si esto llegase a ocurrir puede causar lesiones graves o fatales.

IMPORTANT INFORMATION, PLEASE READ THE INSTRUCTIONS CAREFULLY.

1. Fix the mounting bracket (V) on the back of the furniture as shown in the figure, using the screws (F)
2. Locate a post on the wall to attach the mounting bracket (V), place it approximately 1" below the one that is attached to the furniture. Use wall anchors (L) and screws (DE).
3. Move the furniture to its final position, taking care to align the wall mounting bracket with the cabinet mounting bracket. Pass the clamp (E) through each bracket as shown in the picture and tighten enough until it is snug.
4. Make sure all parts are tight.

INFORMACION IMPORTANTE, LEA POR FAVOR CUIDADOSAMENTE LAS INSTRUCCIONES.

1. Monte el soporte de montaje (V) en la parte posterior del mueble como se muestra en la figura anterior, utilizando los tornillos (F)
2. Localice un poste en la pared en donde fijará el soporte de montaje (V), colóquelo aproximadamente 1" por debajo del que fijó en el mueble. Utilice los anclajes de pared (L) y los tornillos (DE).
3. Mueva el mueble a su posición final, cuidando de alinear el soporte de montaje de la pared con el soporte de montaje del mueble. Pase la abrazadera (E) a través de cada soporte como se muestra en la imagen y apriete lo suficiente hasta que quede ajustado.
4. Asegúrese que todas las piezas estén firmemente ajustadas.

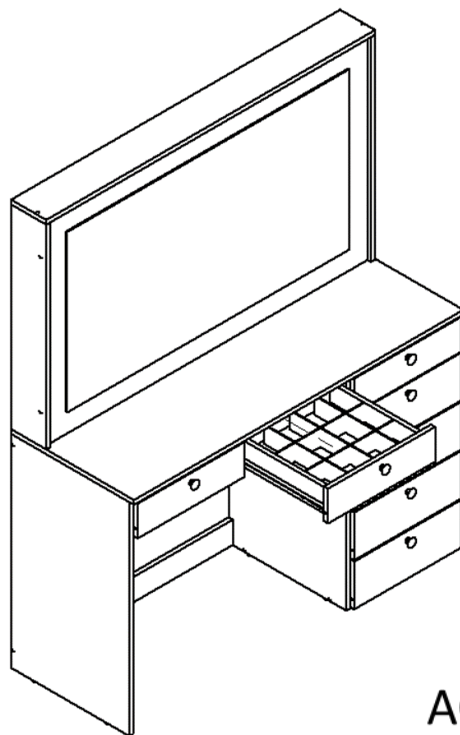
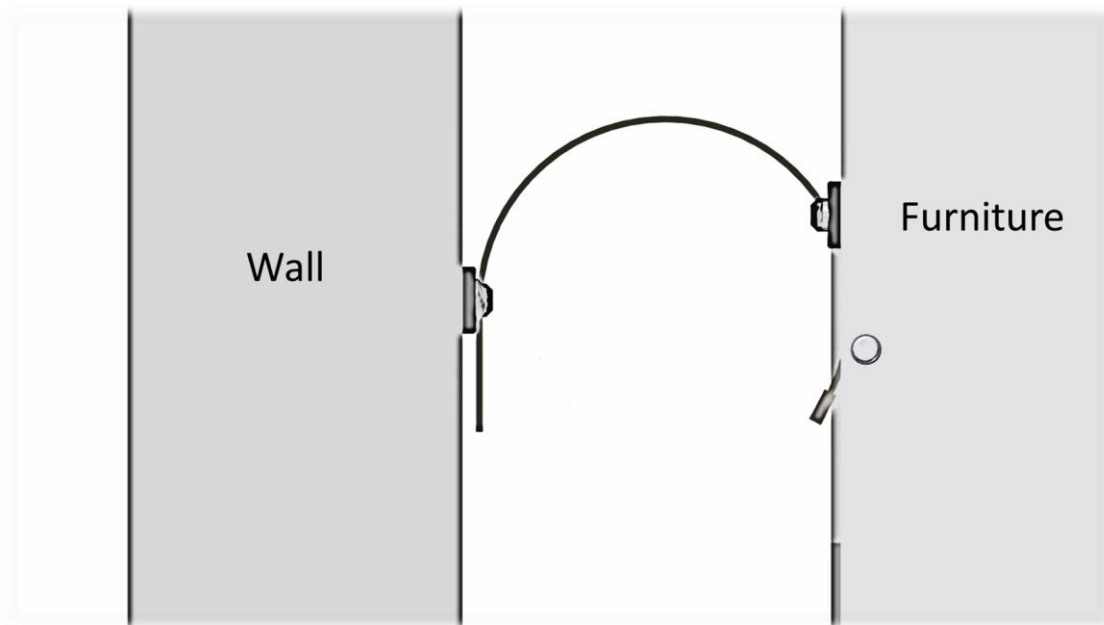

AG



***Congratulations, you have assembled your DRESSING TABLE WITH MIRROR!!!
¡¡¡Felicitaciones, has armado tu Tocador con Espejo!!!***

DRESSING TABLE WITH MIRROR Warranty

6-Months Limited Warranty

- a. We provide limited warranty coverage to the original purchaser of this product for a period of six months from the date of purchase against defects in materials or workmanship of furniture components. As used in this Warranty, "defect" means imperfections in components which substantially impair the utility of the product. This Warranty gives you specific legal rights, and you may also have other rights which vary from state to state.
- b. There is no warranty coverage for defects or conditions that result from the failure to follow product assembly instructions, information or warnings, misuse or abuse, intentional damage, fire, flood, alteration or modification of the product, or use of the product in a manner inconsistent with its intended use, nor any condition resulting from incorrect or inadequate maintenance, cleaning, or care. There is also no warranty coverage for rented products or any products purchased "used" or "as is", at a distress or going-out of business sale, or from a liquidator.
- c. As the exclusive remedy under this Warranty, we will (at its sole option) repair, replace or refund the value of any defective furniture component. We may require independent confirmation of the claimed defect and proof of purchase. Replacement parts will be warranted for only the remaining period of the original Warranty. WE SHALL HAVE NO LIABILITY for ANY INCIDENTAL OR CONSEQUENTIAL DAMAGES OF ANY KIND and all such damages are EXCLUDED FROM THIS WARRANTY, such as loss of use, disassembly, transportation, labor or damage to property on or near the product. Some states do not allow the exclusion or limitation of incidental or consequential damages, so the above limitation or exclusion may not apply to you.
- d. This Warranty applies only to warranted defects that first arise and are transferred to subsequent owners or users of the product, and it shall be immediately void in the event the product is resold, transferred, leased or rented to any third party or person other than the original purchaser.
- e. THERE ARE NO OTHER WARRANTIES APPLICABLE TO THIS PRODUCT. Under the laws of certain states, there may be no implied warranties from us and all implied warranties, INCLUDING ANY IMPLIED WARRANTY OF MERCHANTABILITY OR FITNESS FOR A PARTICULAR PURPOSE are disclaimed where allowed by law. TO THE EXTENT ANY IMPLIED WARRANTIES ARE APPLICABLE, ANY IMPLIED WARRANTIES, INCLUDING ANY IMPLIED WARRANTY OF MERCHANTABILITY OR FITNESS FOR A PARTICULAR PURPOSE, ARE LIMITED IN DURATION TO THE DURATION OF THIS EXPRESS WARRANTY or the minimum period allowed by law, whichever is shorter. Some states do not allow limitations on how long an implied Warranty lasts, so the above limitation may not apply to you.

Please include your sales receipt or other proof of purchase and a specific description of the product defect.

Garantía de Tocador con Espejo

Garantía limitada de 6 meses

1. proporciona cobertura de garantía limitada al comprador original de este producto por un período de 6 meses a partir de la fecha de compra contra defectos en materiales o mano de obra de componentes de muebles de . Como se especifica en esta Garantía, "defecto" significa imperfecciones en componentes que perjudican sustancialmente la utilidad del producto. Esta Garantía le otorga derechos legales específicos y también puede tener otros derechos que varían de un estado a otro.
2. No hay cobertura de garantía por defectos o condiciones que resulten del incumplimiento de las instrucciones del producto, o advertencias, uso indebido o abuso, daño intencional, incendio, inundación, alteración o modificación del producto o uso del producto de manera inconsistente con su uso previsto, o cualquier condición resultante de mantenimiento incorrecto o inadecuado, limpieza o cuidado. Tampoco hay cobertura de garantía para productos alquilados o cualquier producto comprado "usado" o "tal cual", en una venta de emergencia o de salida de la empresa, o de un liquidador.
3. puede requerir una confirmación independiente del defecto reclamado y un comprobante de compra. Las piezas de repuesto estarán garantizadas durante el período restante de la garantía original. NO TENDRÁ NINGUNA RESPONSABILIDAD POR CUALQUIER DAÑO INCIDENTAL y todos estos daños ESTÁN EXCLUIDOS DE ESTA GARANTÍA, tales como pérdida de uso, desmontaje, transporte, mano de obra o daños a la propiedad en o cerca del producto. Algunos estados no permiten la exclusión o limitación de daños incidentales o consecuentes, por lo que la limitación o exclusión anterior puede no aplicarse a usted.
4. Esta Garantía se aplica únicamente a los defectos garantizados que surgen y se informan a dentro del período de cobertura de la garantía. La garantía no puede ser transferida a los propietarios o usuarios posteriores del producto, y será inmediatamente nula en caso de que el producto sea revendido, transferido, arrendado o alquilado a cualquier tercero o persona que no sea el comprador original.
5. NO HAY OTRAS GARANTÍAS APLICABLES A ESTE PRODUCTO. Bajo las leyes de ciertos estados, no puede haber garantías implícitas de y todas las garantías implícitas, INCLUYENDO CUALQUIER GARANTÍA IMPLÍCITA DE COMERCIALIZACIÓN O ADECUACIÓN PARA UN PROPÓSITO EN PARTICULAR, están exoneradas cuando permitido por la ley. TODAS LAS GARANTÍAS IMPLÍCITAS SON APLICABLES, LAS GARANTÍAS IMPLÍCITAS, INCLUIDAS CUALQUIER GARANTÍA IMPLÍCITA DE COMERCIALIZACIÓN O ADECUACIÓN PARA UN PROPÓSITO PARTICULAR, ESTÁN LIMITADAS EN DURACIÓN A LA DURACIÓN DE ESTA GARANTÍA EXPRESA o el período mínimo permitido por la ley, cualquiera que sea más corto. Algunos estados no permiten limitaciones sobre la duración de una garantía implícita, por lo que es posible que la limitación anterior no se aplique a usted.

Incluya su recibo de compra u otra prueba de compra y una descripción específica del defecto del producto.