

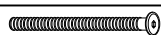







Assembly Instruction

Item No.: F2523

PART LIST		
ITEM	DESCRIPTION	QTY
A	TABLE TOP	1 PC
B	TABLE LEG	2 PCS
C	RAIL	1 PC

HARDWARE LIST		
ITEM	DESCRIPTION	QTY
1	JCBC SCREW M6 x 50MM 	4 PCS
2	SPRING WASHER 1/4" 	4 PCS
3	SPRING WASHER 5/16" 	8 PCS
4	FLAT WASHER 5/16" 	8 PCS
5	HEX NUT 5/16" 	8 PCS
6	WOOD DOWEL M10 X 35MM 	2 PCS
7	WOOD BUTTON 	4 PCS
8	SPANNER 	1 PC
9	M4 ALLEN KEY 	1 PC

Step 1:

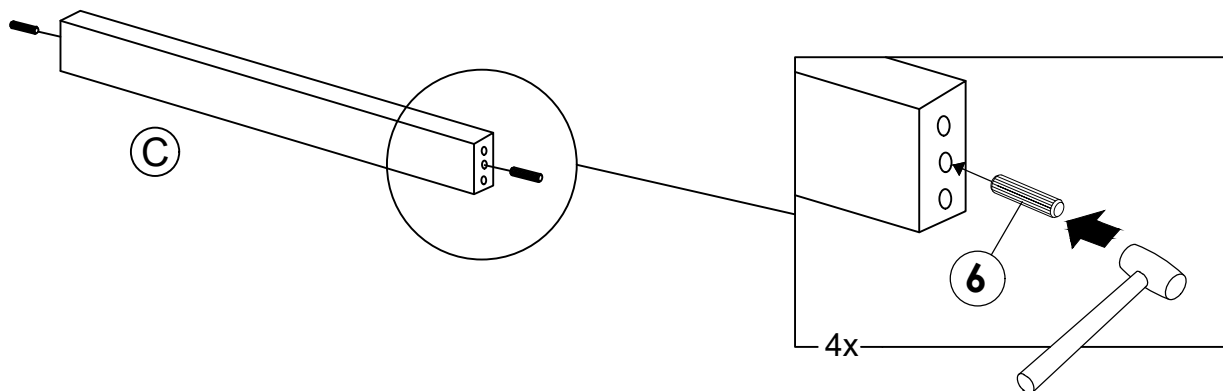

Step 2:

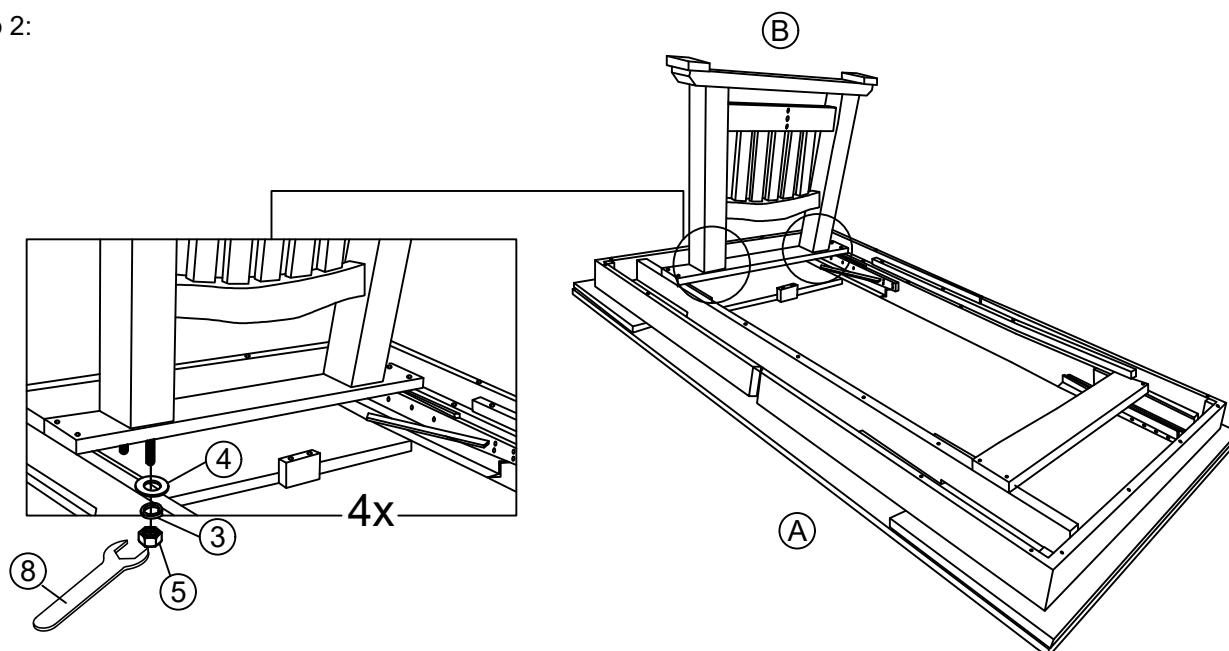

Step 3:

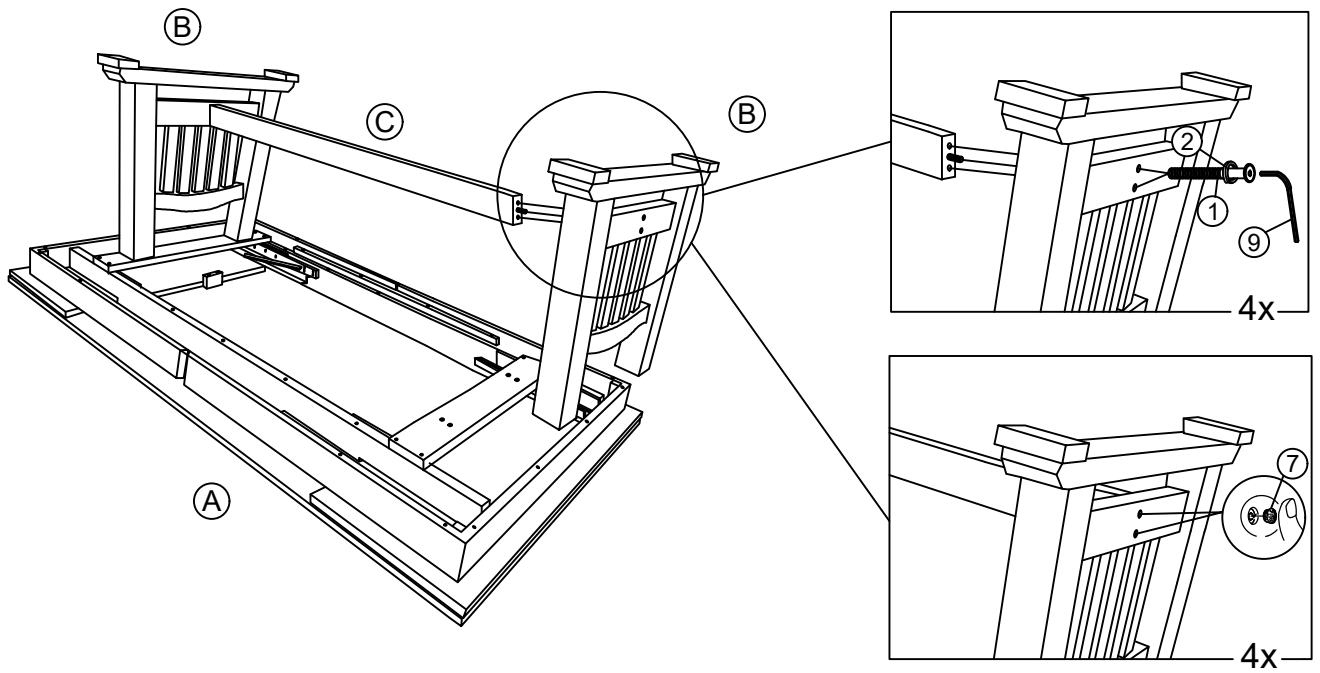

Step 4:

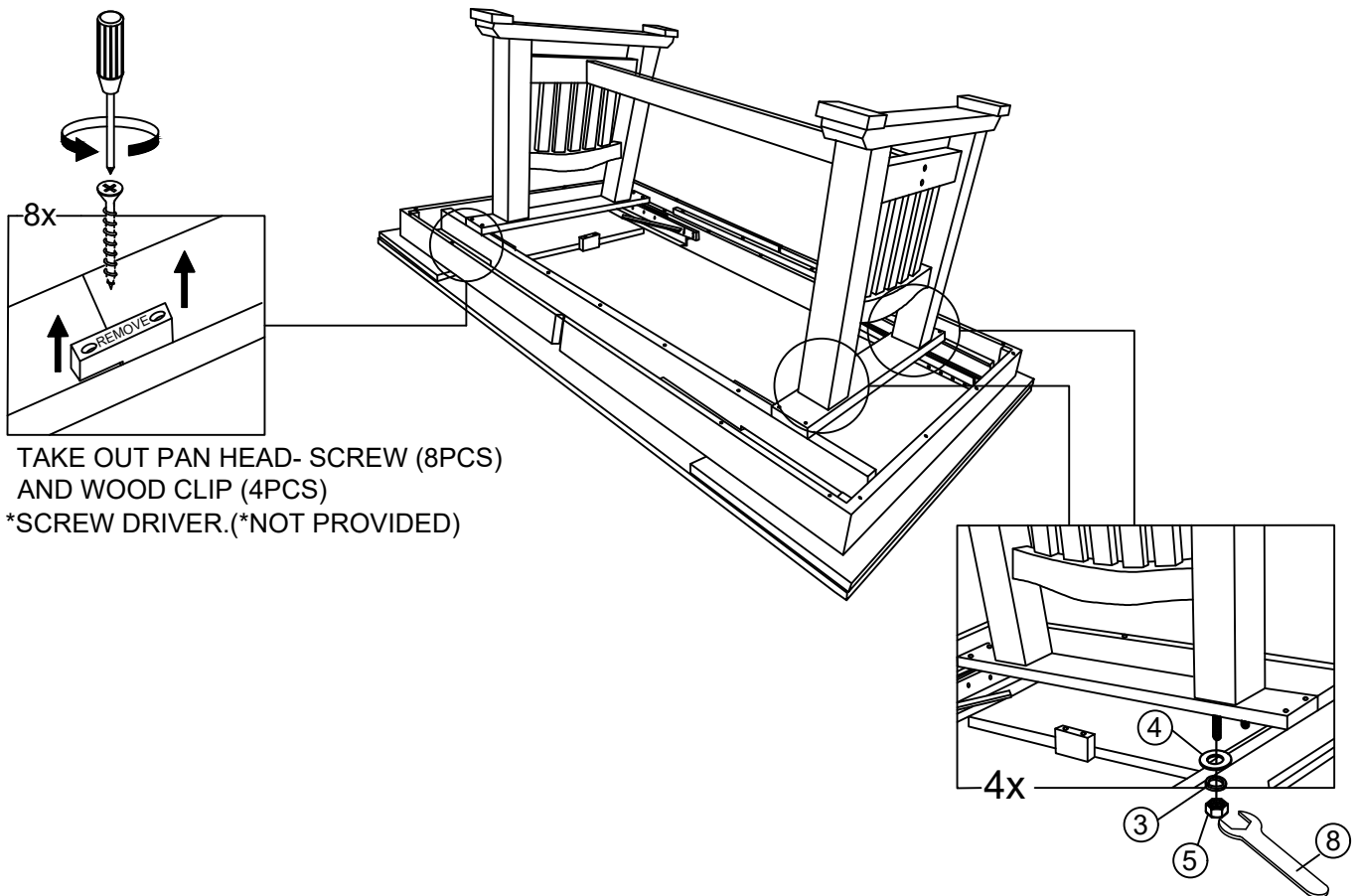

Step 5:

To Operate

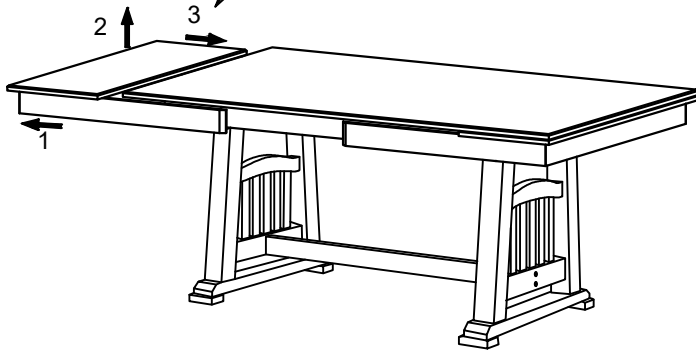
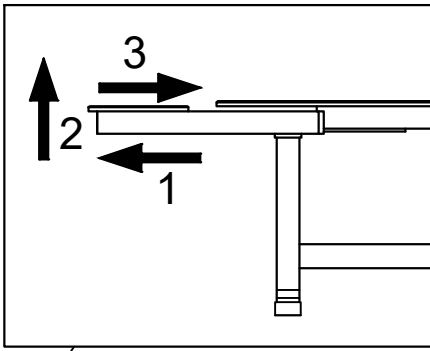

To Storage

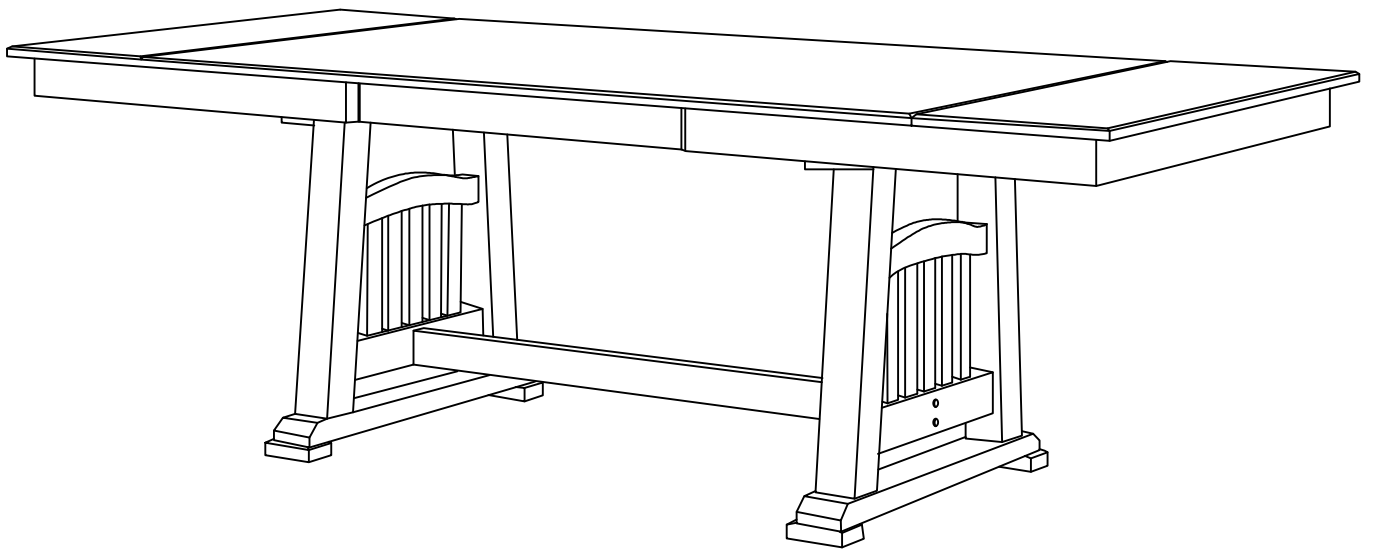
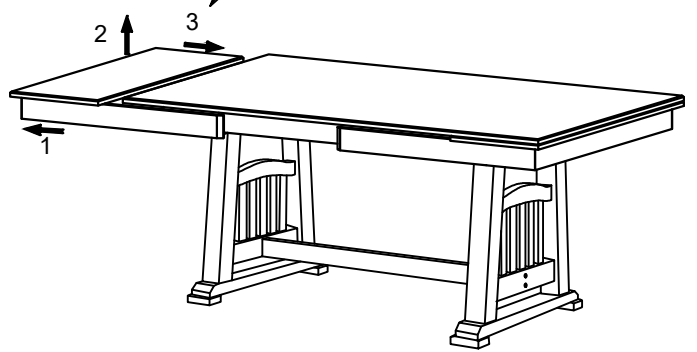
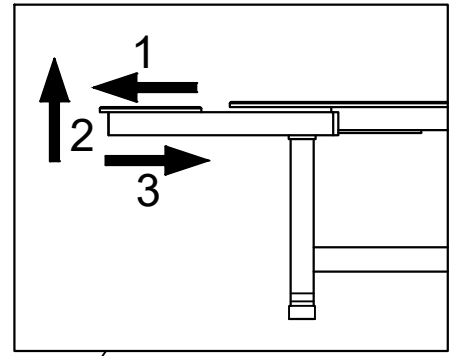

COMPLETED ASSEMBLY