

NOTE:

This brochure contains **IMPORTANT** safety info. Please read and keep for future reference.

MAINTAINANCE AND WARNING

- 1.Keep furniture away from heat sources.
- 2.Do not clean furniture with harsh cleaner or polishes.Do not use detergents,solvents,abrasives,spray packs or leather cleaner. Use non-color mild soap with warm water to clean spills(Mix 1:10 soap to water).
- 3.Do not place furniture under direct sunlight,material will possibly fade over time.
- 4.Do not use on site dry cleaning machine.Children should not climb or jump on the furniture.
- 5.Do not write on furniture that is not protectedby a padded barrier.
- 6.Not for commercial use,only for residential use.

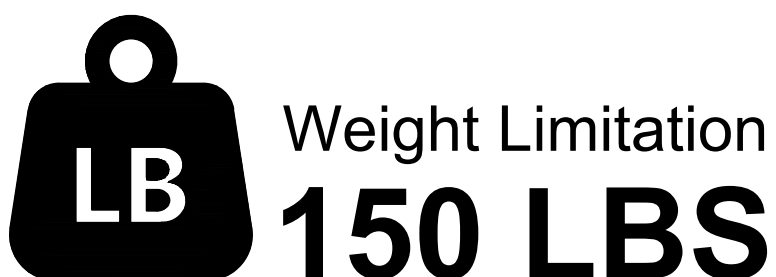



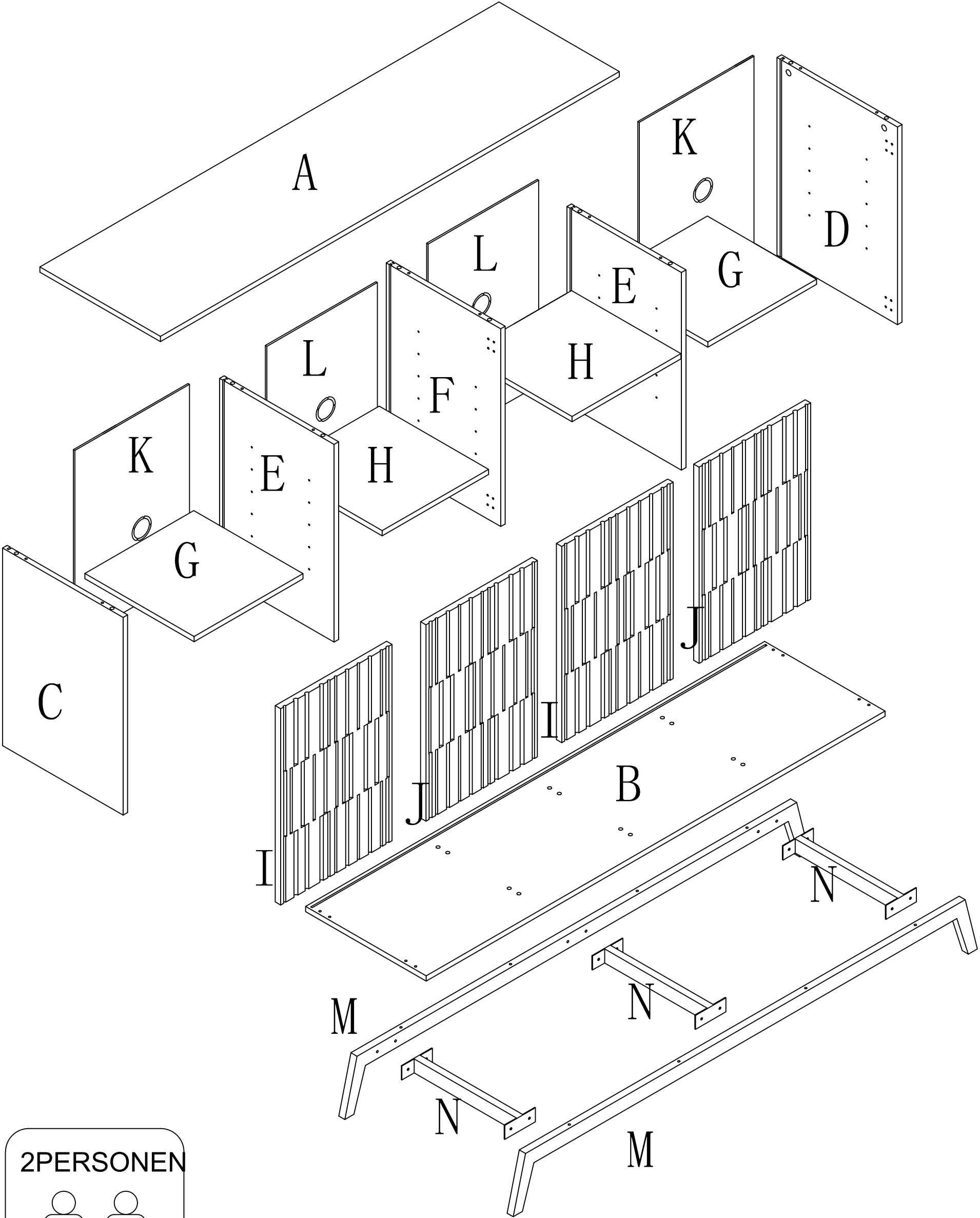

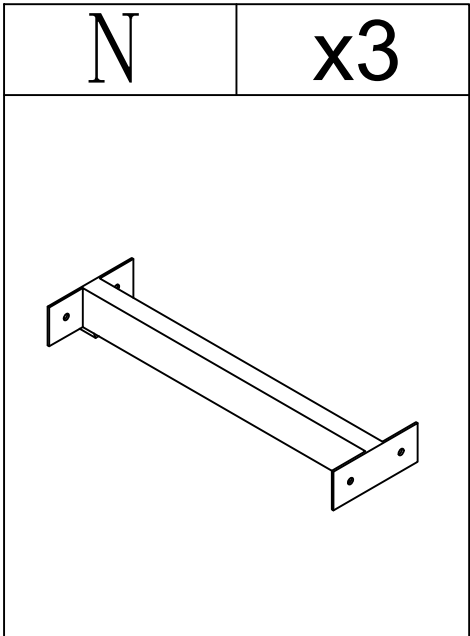
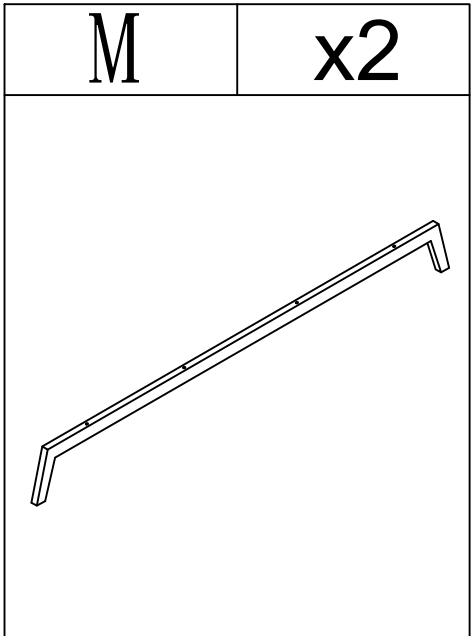
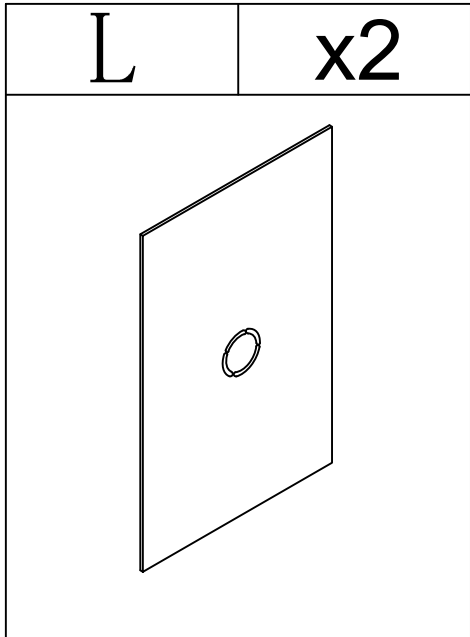
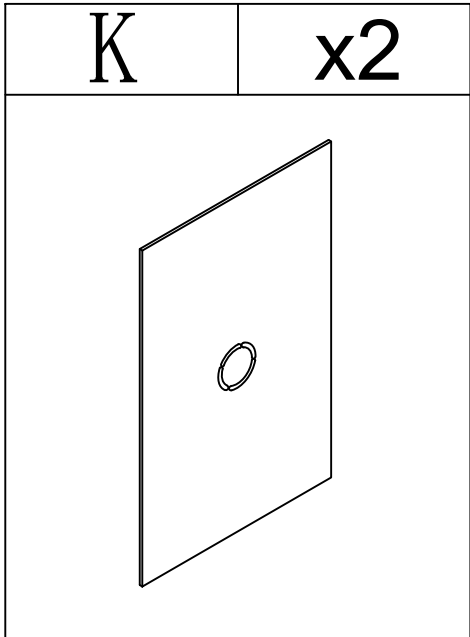
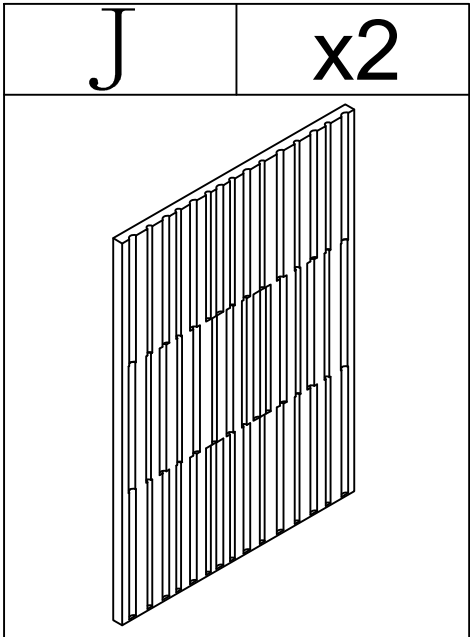
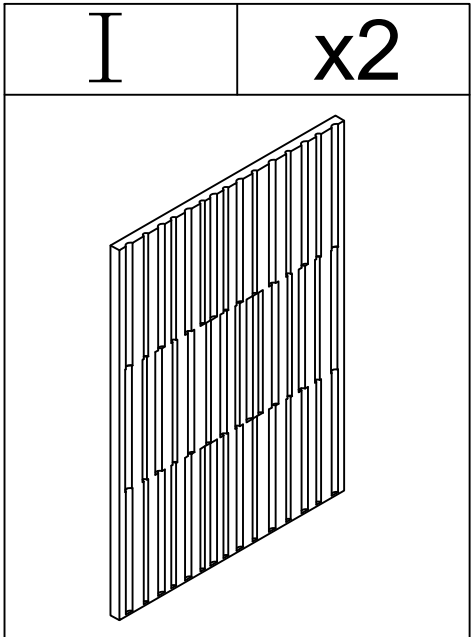
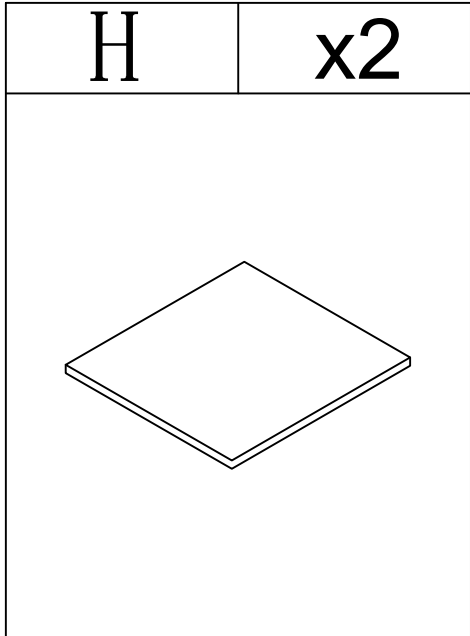
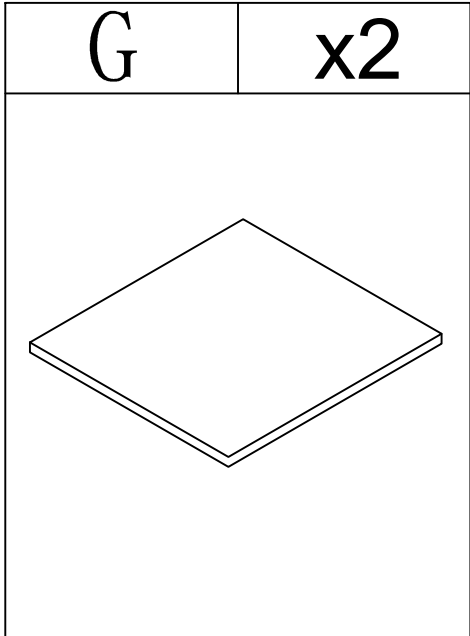
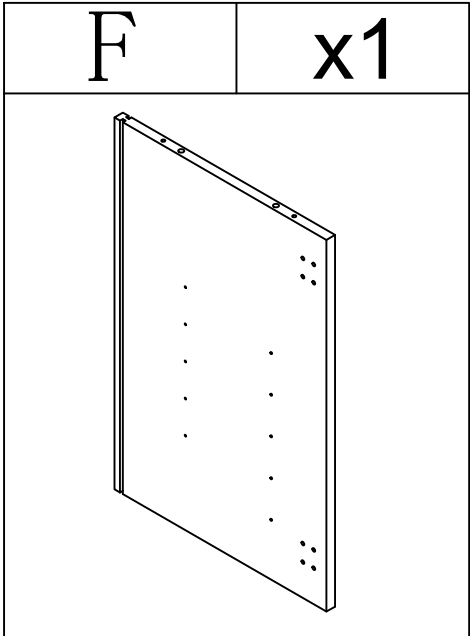
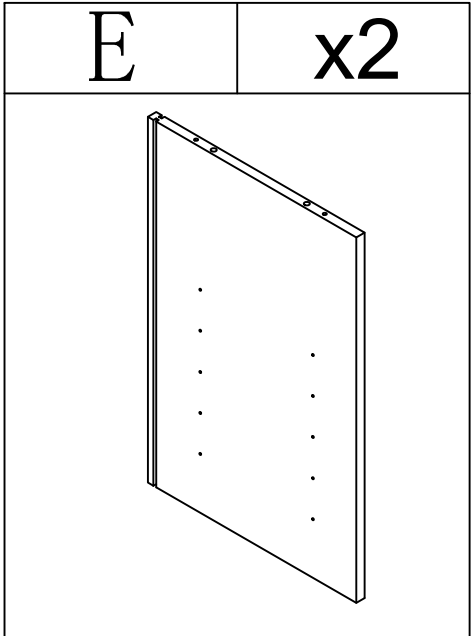
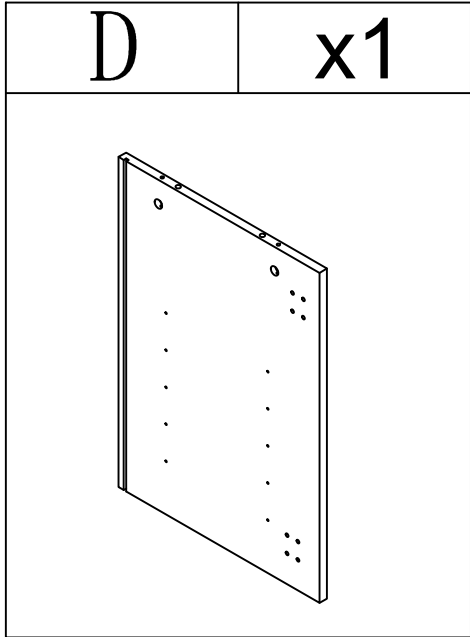
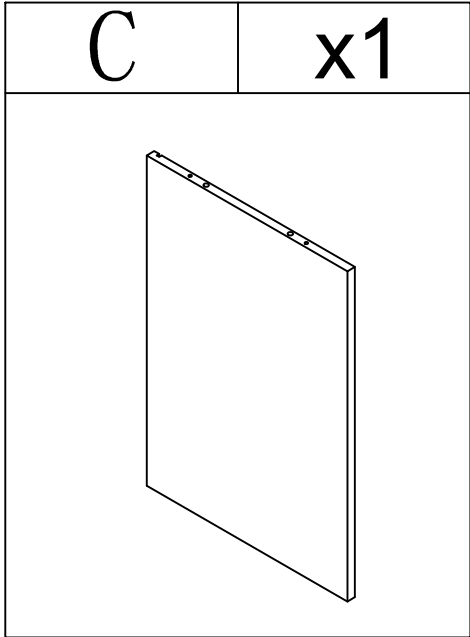
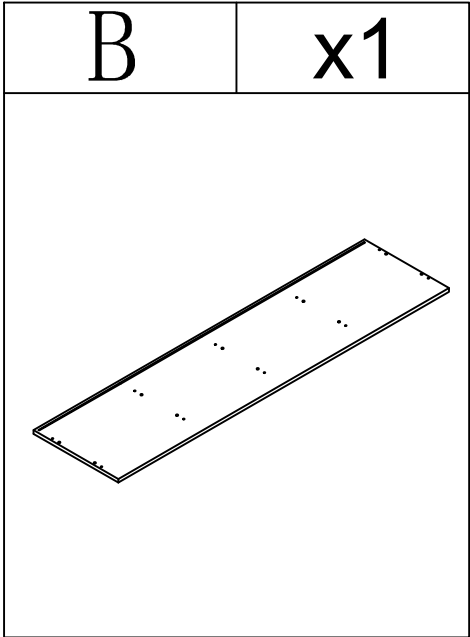
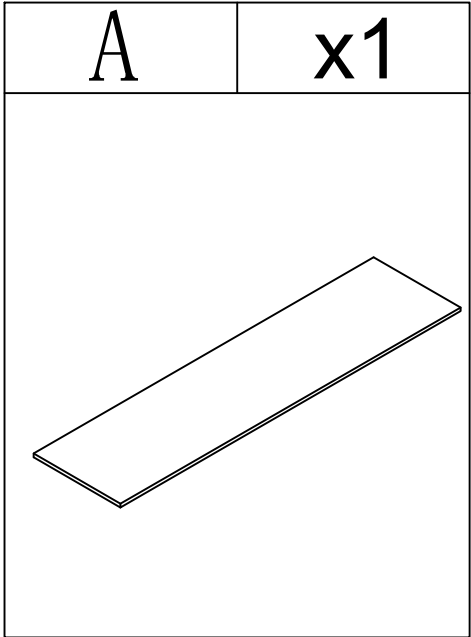

EXPLOSIVE VIEW

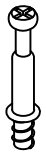

PARTS LIST

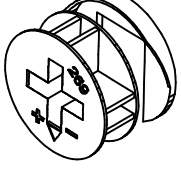
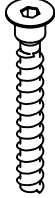
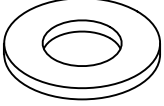

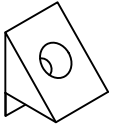
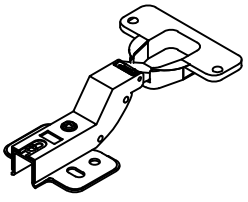
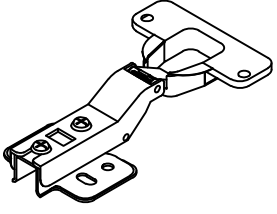
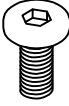
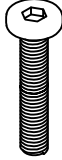
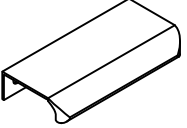
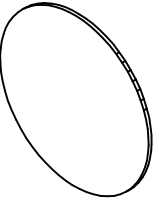

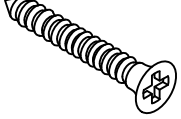
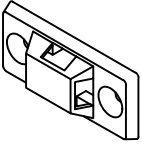
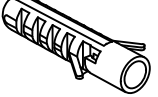
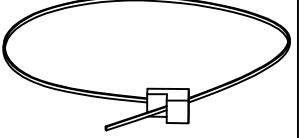

HARDWARE LIST

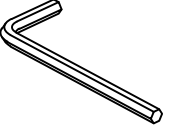
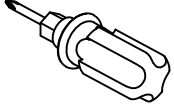
#1	x10	#2	x20	#3	x10	#4	x10	#5	x20	#6	x84
											
Ø6*35mm		Ø8*30mm		Ø15*12mm		Ø7*40mm		Ø17-Ø8*1mm		Ø3.5*14mm	
#7	x24	#8	x4	#9	x4	#10	x12	#11	x8	#12	x4
											
						Ø6*15mm		Ø6mm*50			
#13	x10	#14	x16	#15	x4	#16	x4	#17	x4	#18	x2
											
				Ø4*35mm							

TOOL LIST

#19	x1	#20	x1
			
M4			

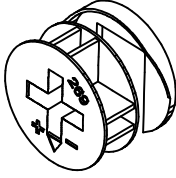
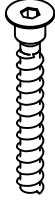
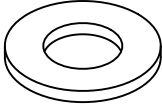
HARDWARE SPARE LIST

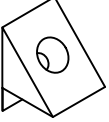
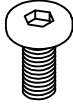
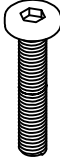
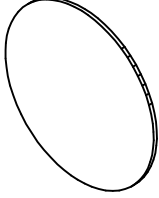
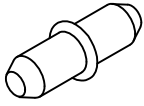

#1	x1	#2	x2	#3	x1	#4	x1	#5	x2	#6	x7
											
Ø6*35mm		Ø8*30mm		Ø15*12mm		Ø7*40mm		Ø17-Ø8*1mm		Ø3.5*14mm	
#7	x24	#10	x1	#11	x1	#13	x1	#14	x1		
											
		Ø6*15mm		Ø6mm*50							

ASSEMBLY INSTRUCTIONS

STEP-1

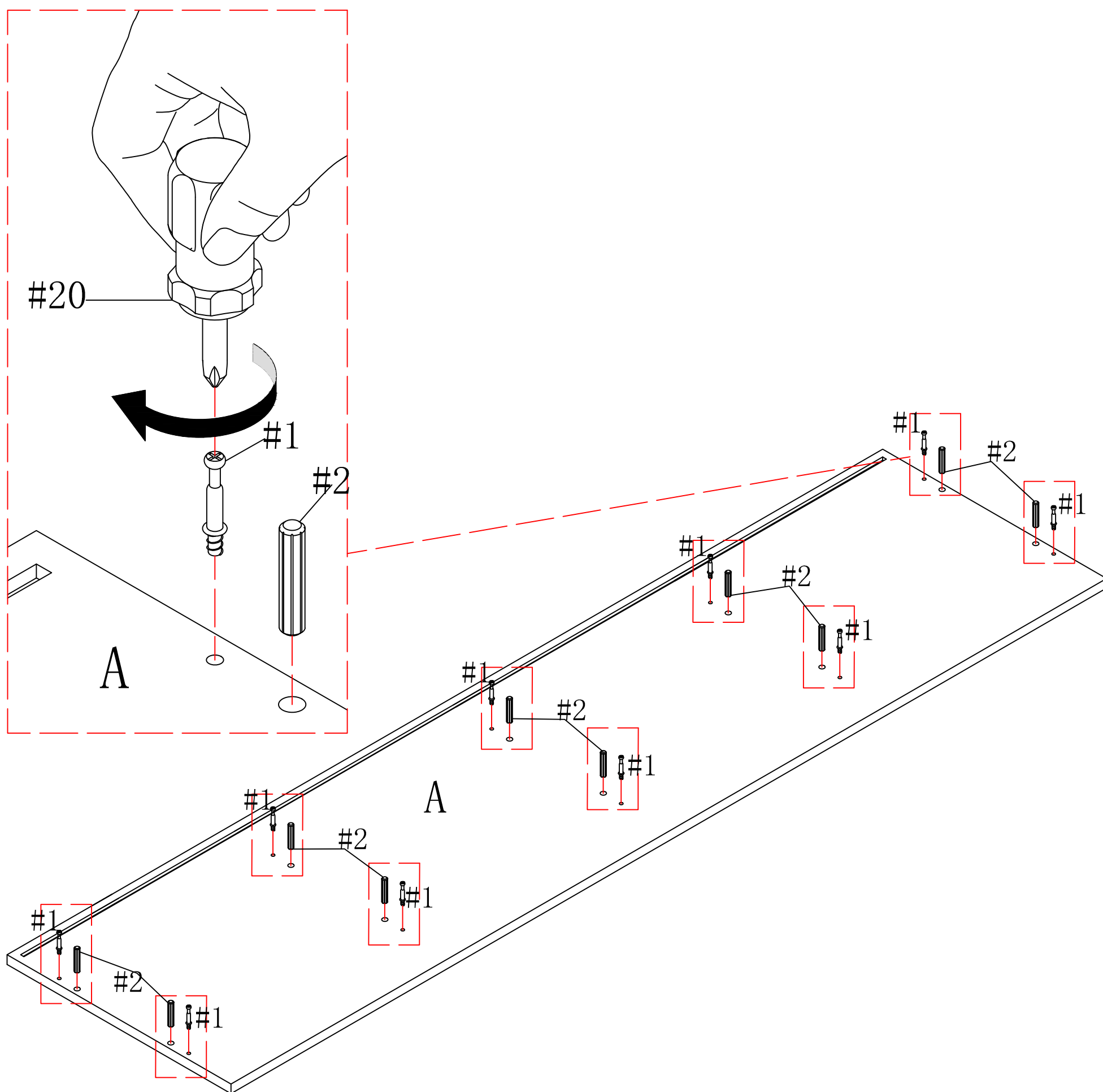
1.Prepare for part A. Align the holes in part A, insert wooden dowel #2 by hand, tighten with screwdriver #20 tighten #1。

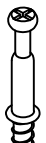

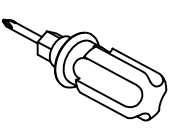
#1	x10	#2	x10	#20	x1
					
Ø6*35mm		Ø8*30mm			

ASSEMBLY INSTRUCTIONS

STEP-2

1. Connect the part A with part C&D&E&F. align the hole in the part C&D&E&F, insert the bolt #1 and wooden dowel #2 in part A into part C&D&E&F. insert cam bolt #3 into the corresponding hole of side panel C&D&E&F, and tighten the nuts #3 with a screwdriver #20. After installation, cover the screw holes with #13. Make sure the groove is in same side as picture show.

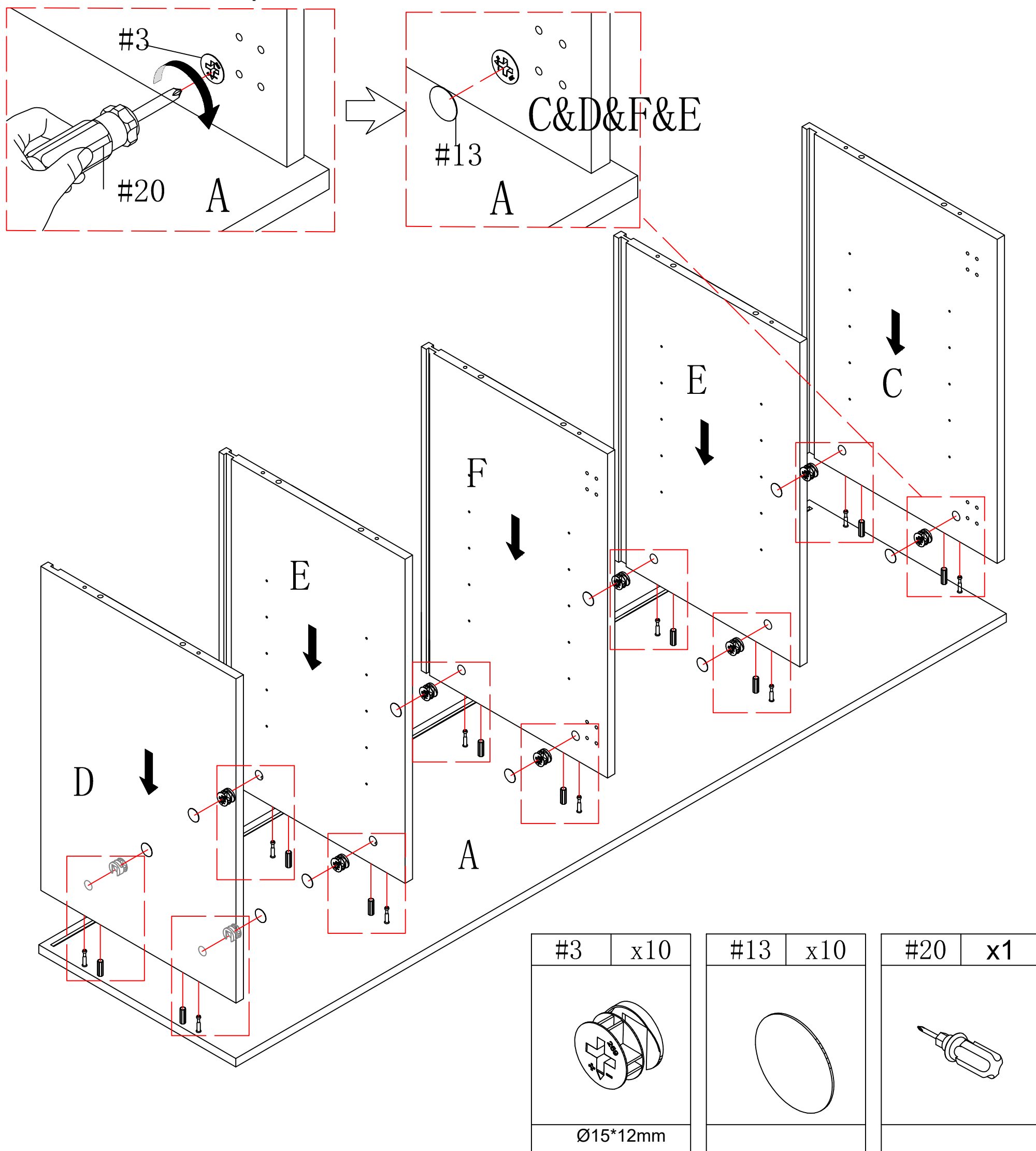

ASSEMBLY INSTRUCTIONS

STEP-3

1. slide in the part L,K into the groove in part D,E and E,F and F,E, and C,E . make sure they are also in groove in part A. Insert the wooden dowel #2 into the part C&D&E&F as the picture show.

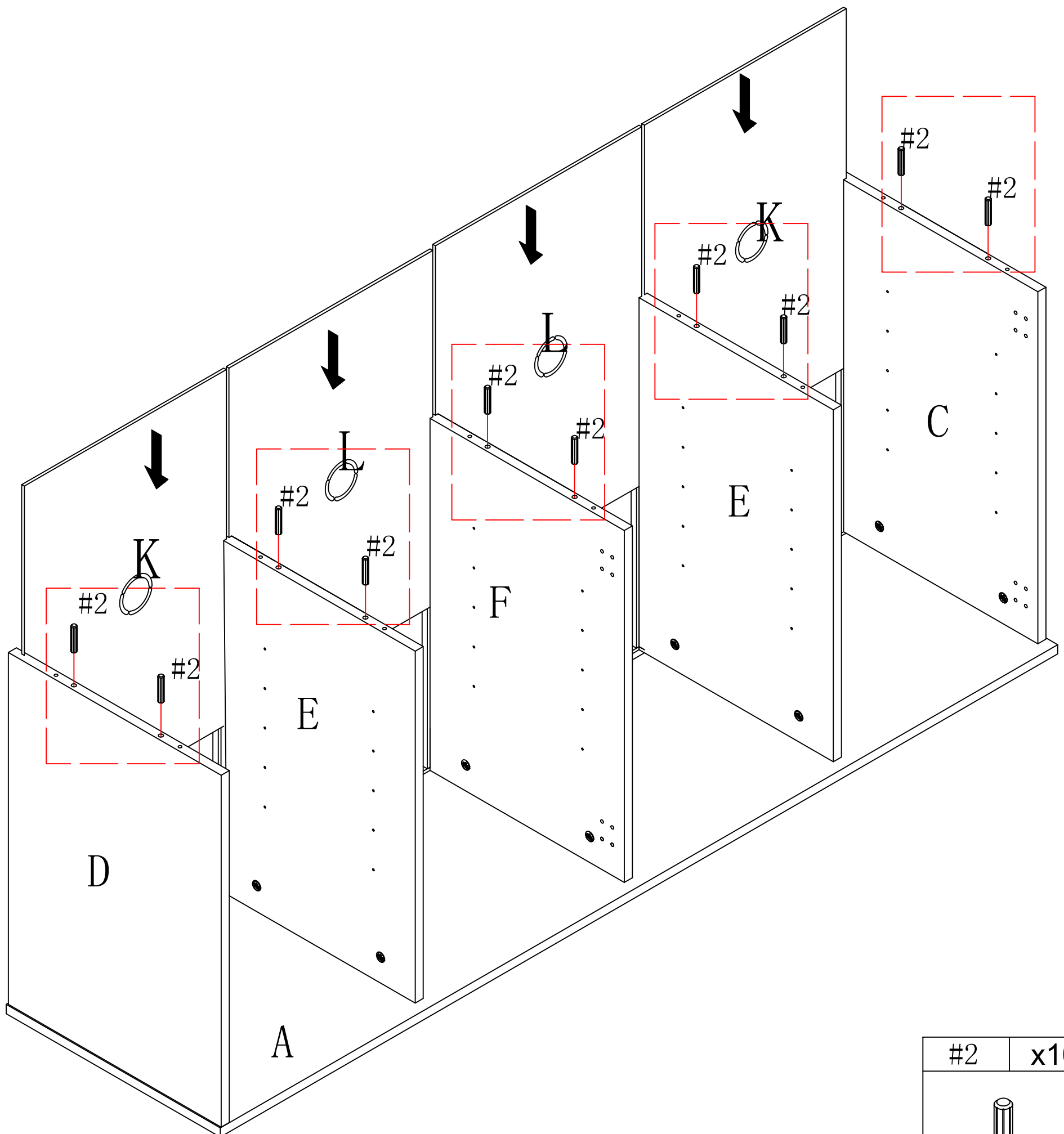

#2	x10
	
Ø8*30mm	

ASSEMBLY INSTRUCTIONS

STEP-4

1. Connect the part B the pre-assembled unit in step 3. Then align the holes in part B, Insert screw #4 and push it down so that it connects to parts C&D&E&F. Next, and tighten the screw #4 with an Allen key #19.

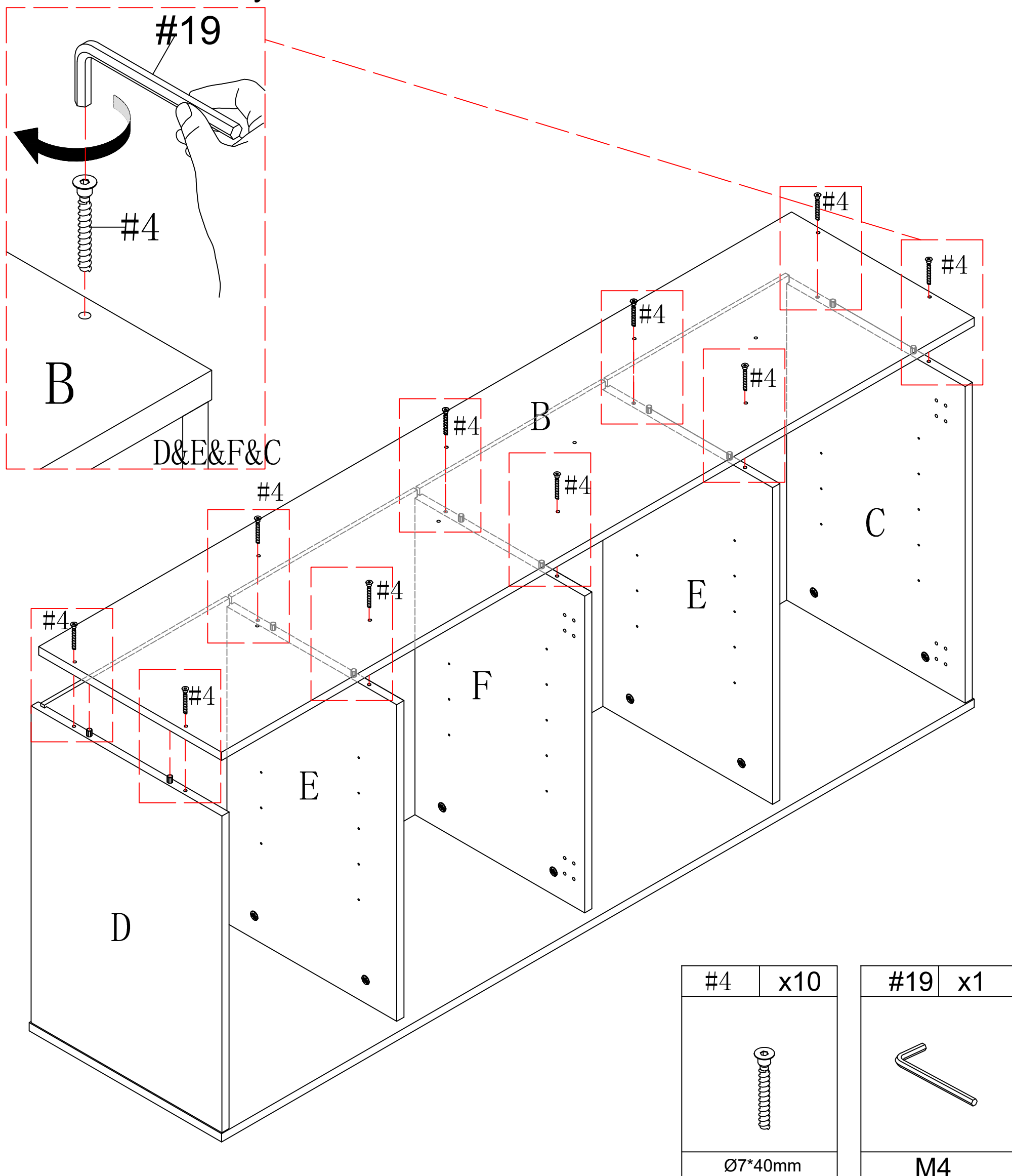

ASSEMBLY INSTRUCTIONS

STEP-5

1. Prepare the leg racks. Align the holes of the N part with the holes of the M part. Place the gasket #5 on the screw #10, insert the screw #10, and tighten the screw #10 with the allen key #19.

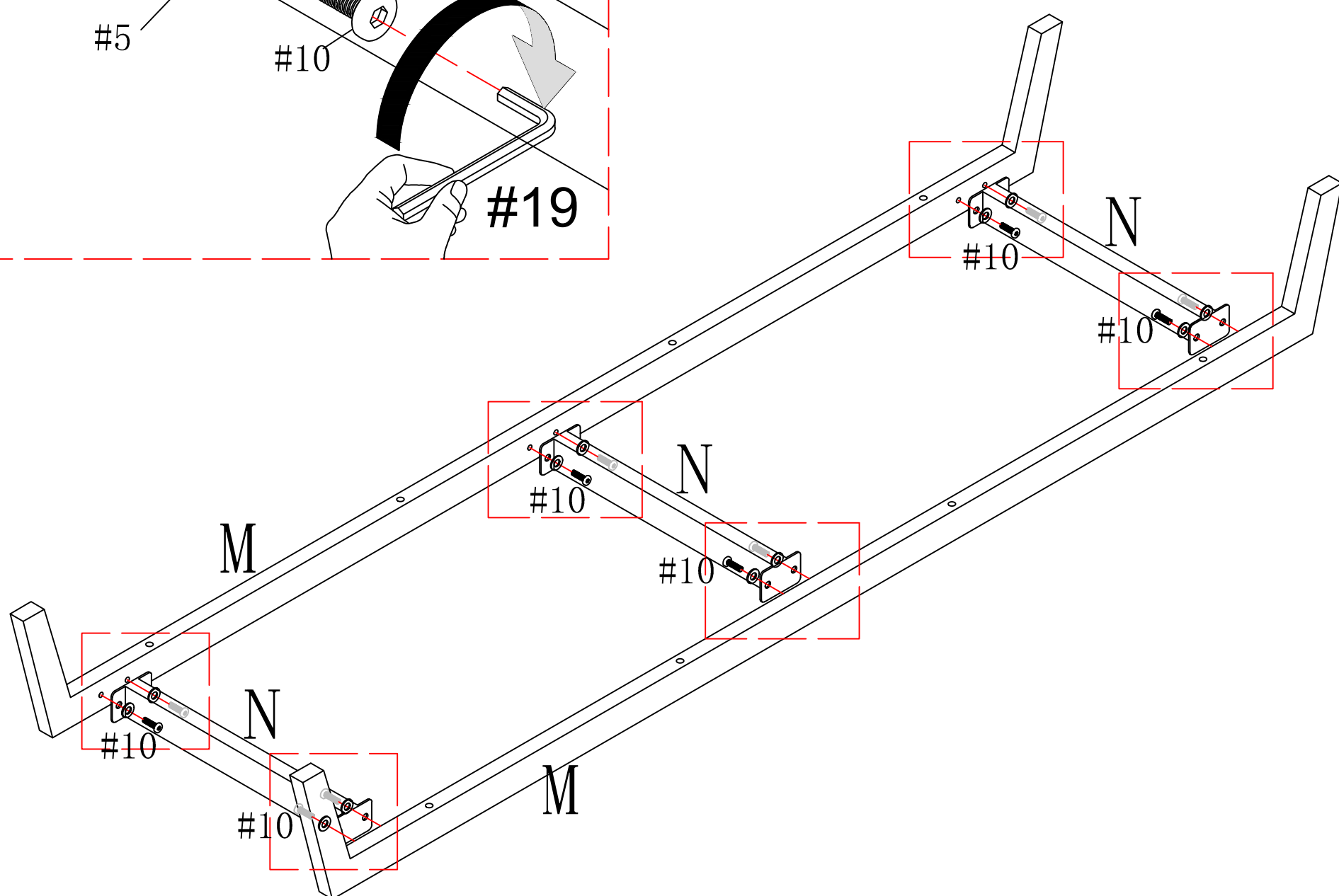
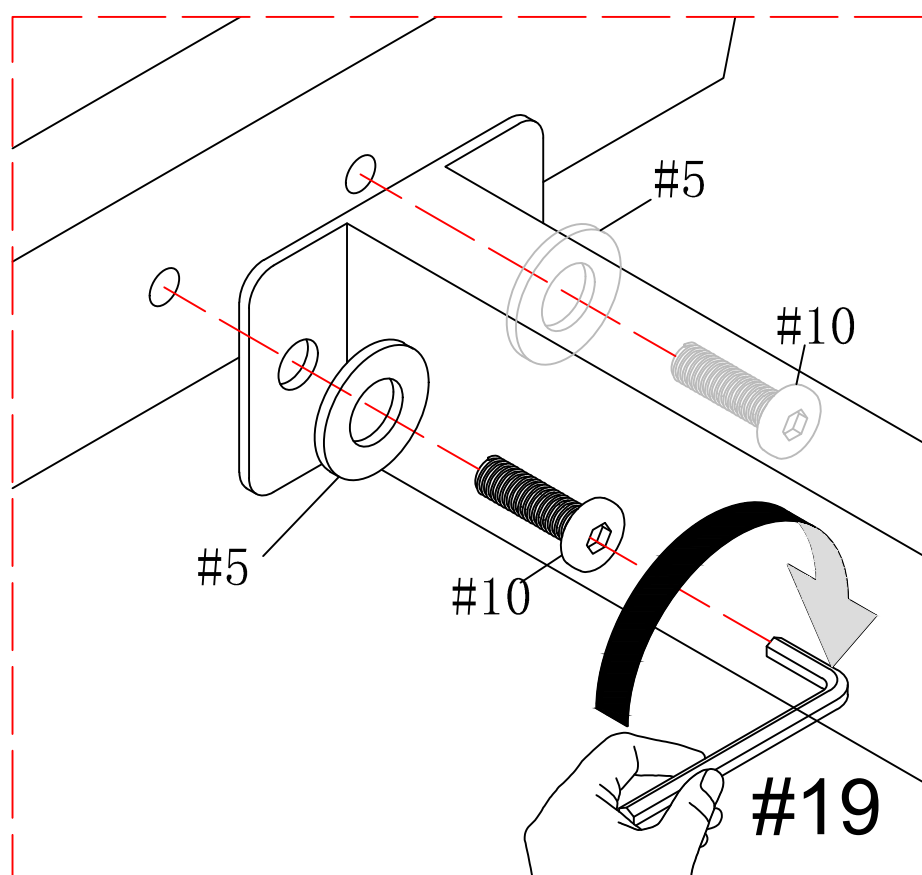

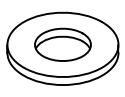
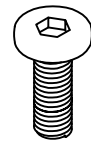
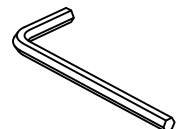
#5	x12	#10	x12	#19	x1
					
Ø17-Ø8*1mm		06*15mm		M4	

ASSEMBLY INSTRUCTIONS

STEP-6

1. connect the leg frame to the cabinet. Attach the leg frame to the pre-assembled unit in step 4 with a screw #11 and tighten #11 with a allen key #19.

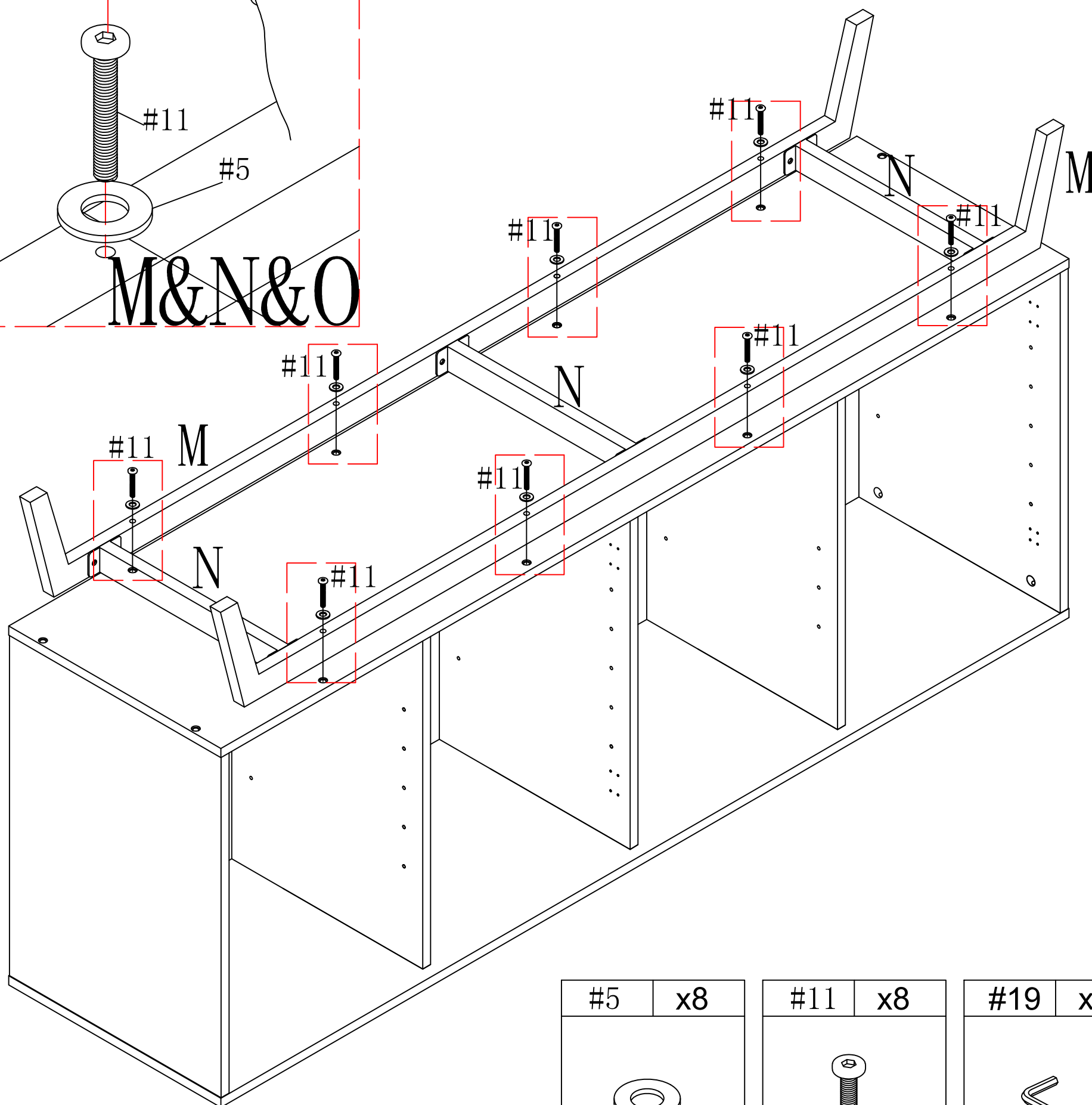
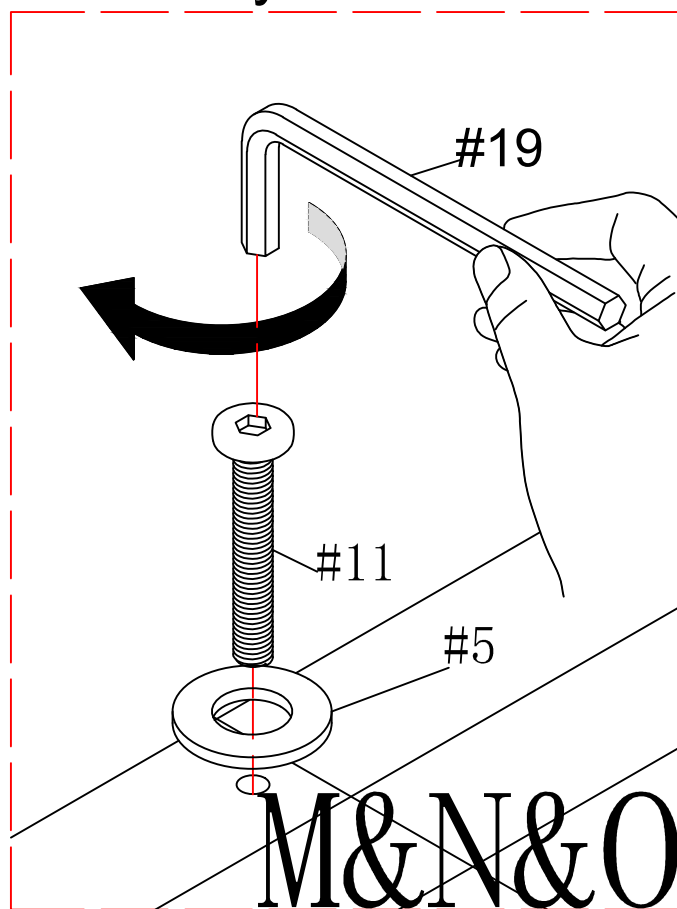

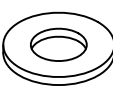
#5	x8
	
Ø17-Ø8*1mm	

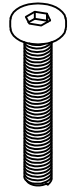
#11	x8
	
06*15mm	

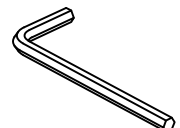
#19	x1
	

ASSEMBLY INSTRUCTIONS

STEP-7

1. Insert hardware #7 into part K&L as shown, screw in screw #6 using screwdriver #20 and tighten fully.

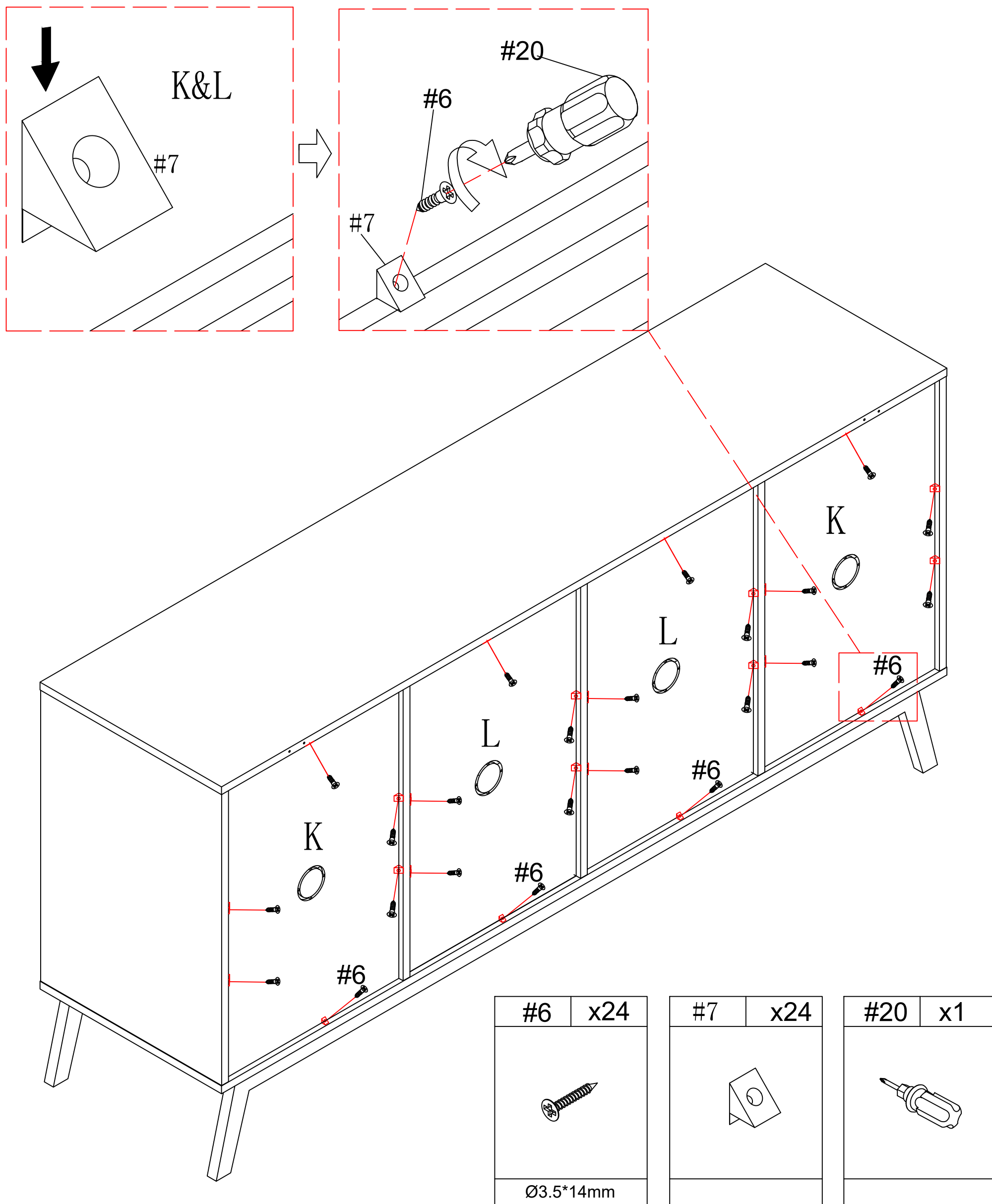



ASSEMBLY INSTRUCTIONS

STEP-8

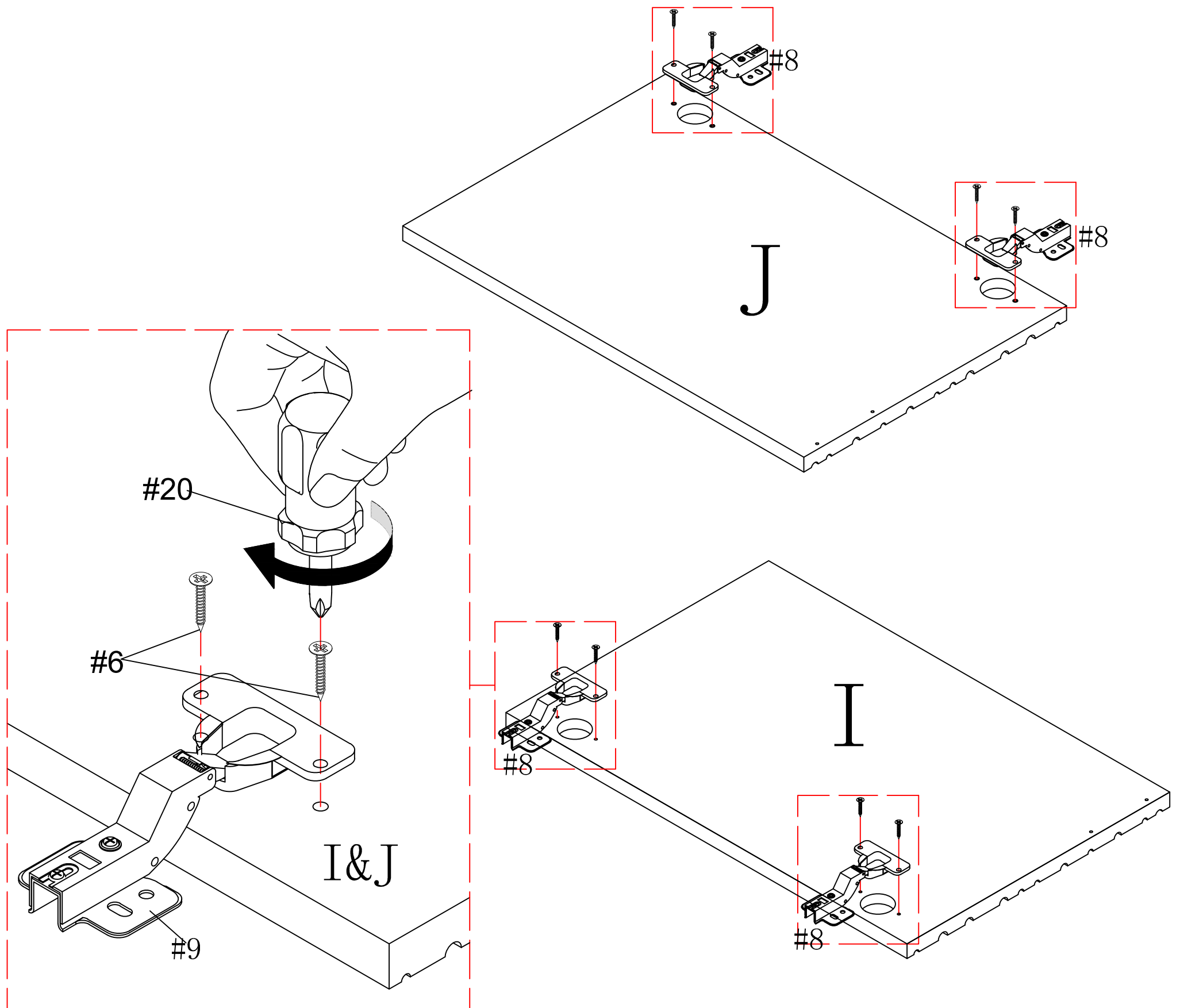
1. Use screw #6 to attach the hinges #8 to door panel (I&J), tighten screws #6 with screwdriver #20.

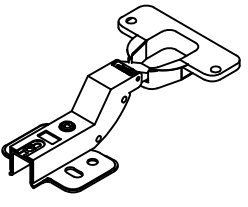

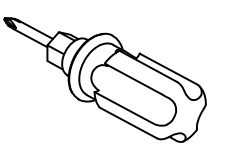
#8	x4	#6	x8	#20	x1
					
		Ø3.5*14mm			

ASSEMBLY INSTRUCTIONS

STEP-9

1. Use screw #6 to attach left door (I) and right door (J) to pre-assemble unit at step 7, tighten screw #6 with screwdriver #20.

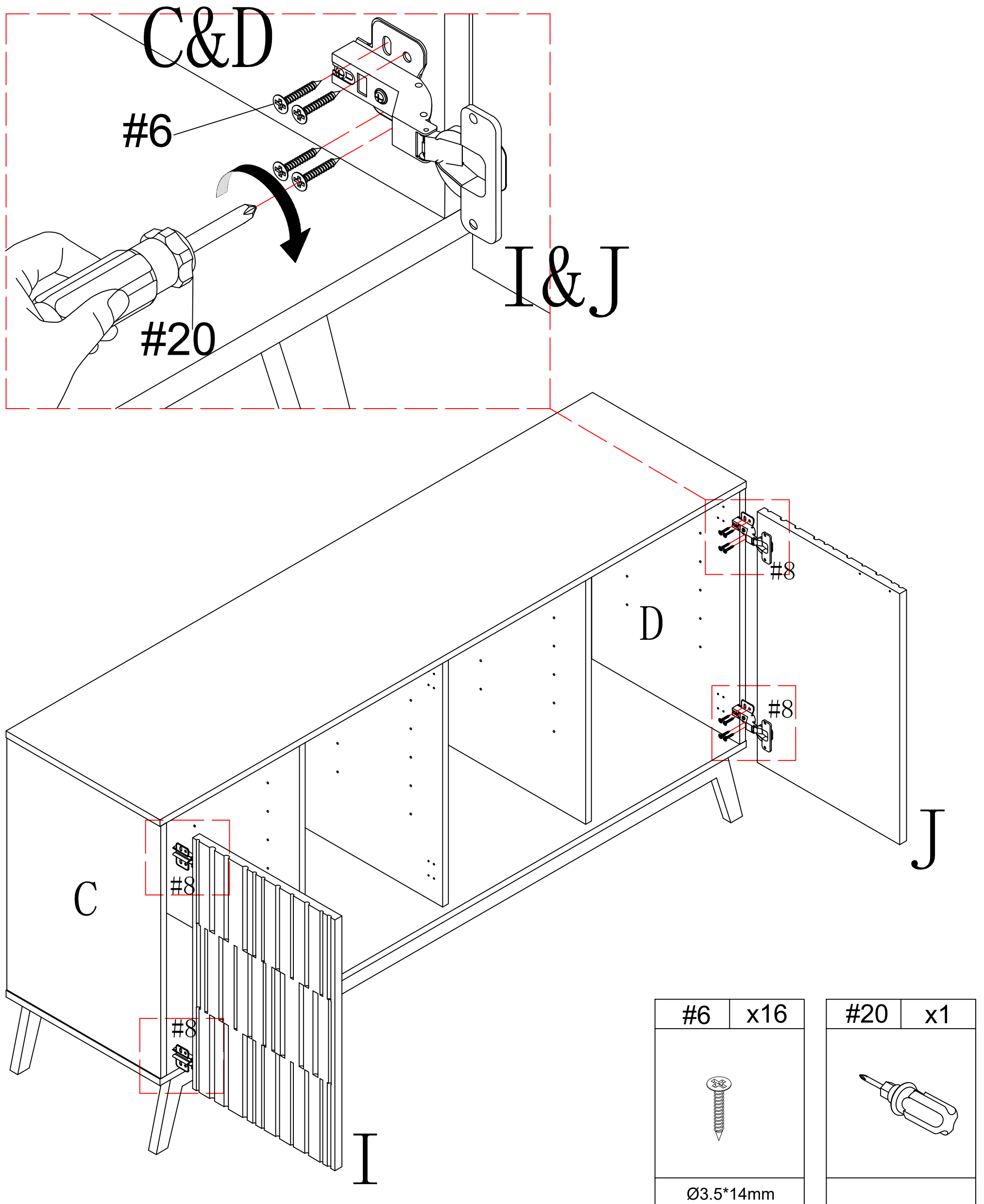

ASSEMBLY INSTRUCTIONS

STEP-10

1. Use screw #6 to attach the hinges #9 to door panel (I&J), tighten screws #6 with screwdriver #20.

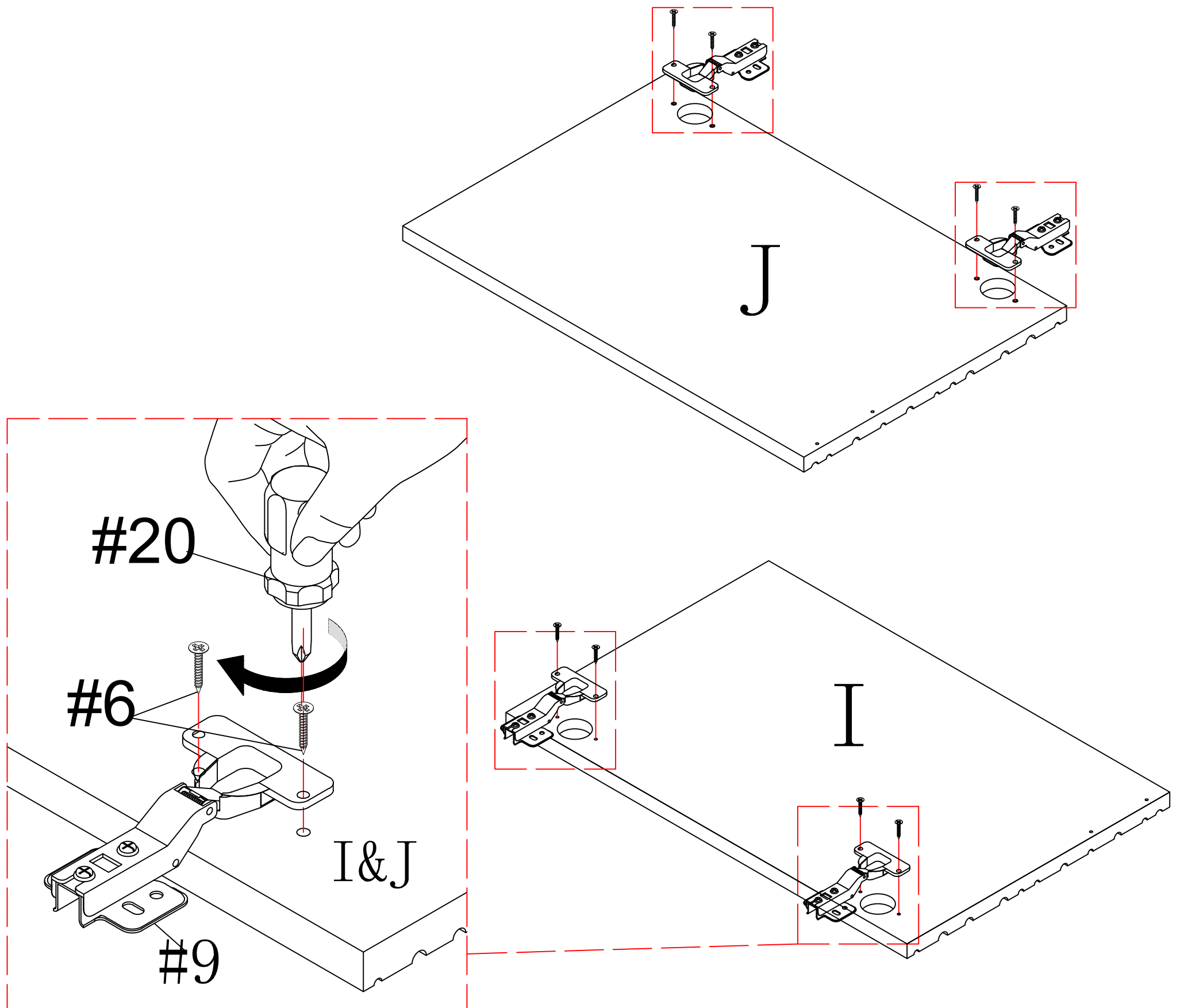

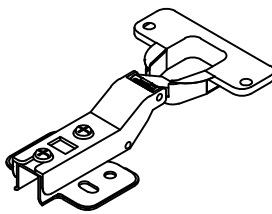
#9	x4
	

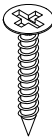
#6	x8
	
Ø3.5*14mm	

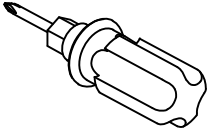
#20	x1
	

ASSEMBLY INSTRUCTIONS

STEP-11

1. Use screw #6 to attach middle door (J) to pre-assemble unit at step 11, tighten screw #6 with screwdriver #20.

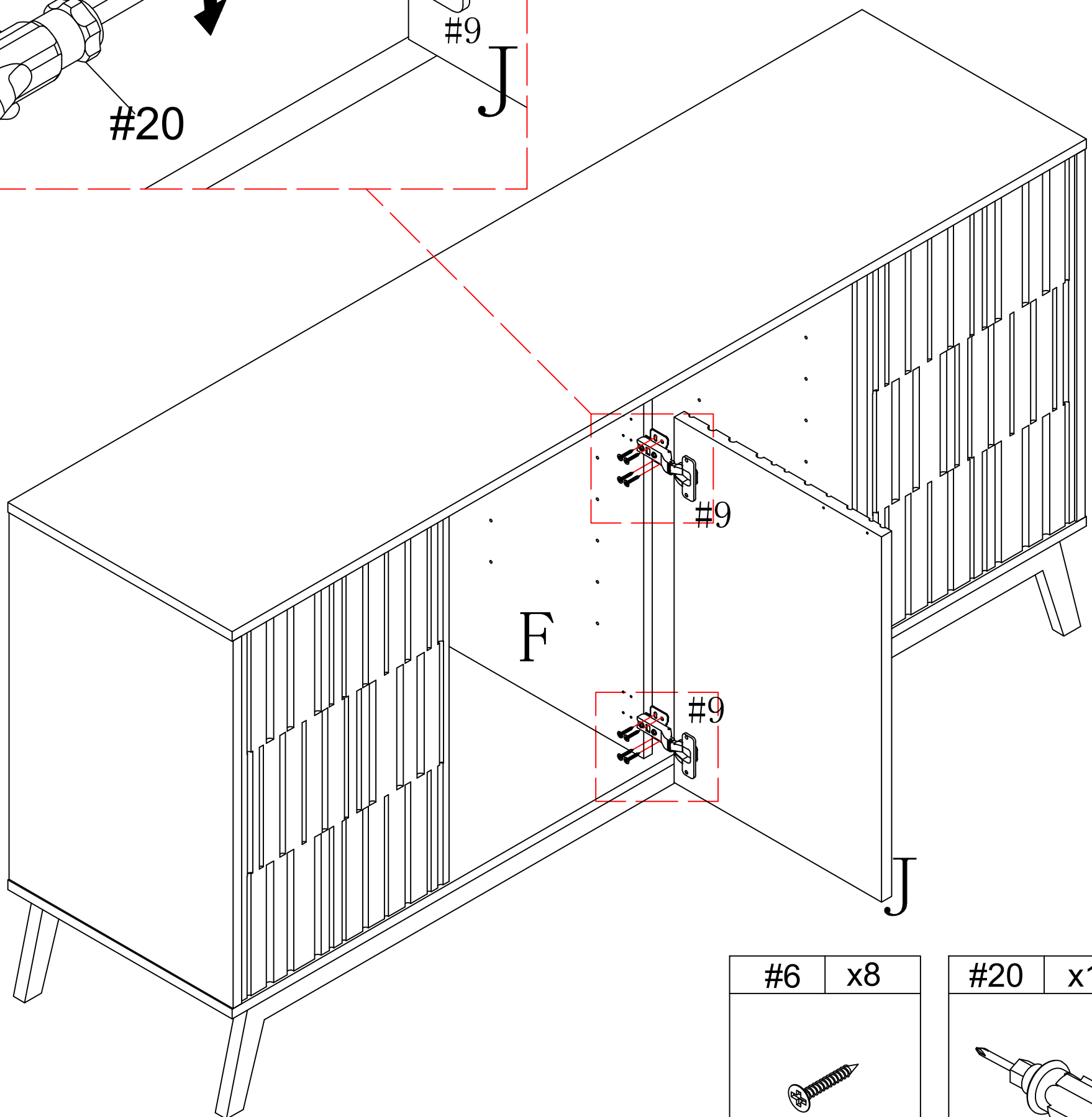
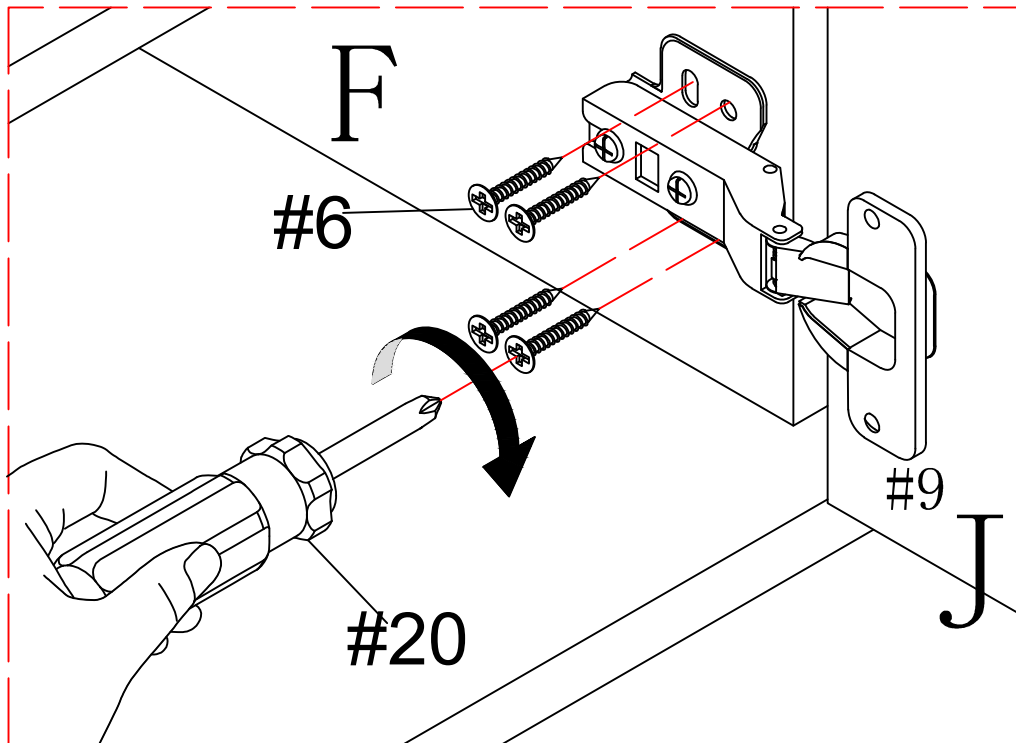

#6	x8
	
Ø3.5*14mm	

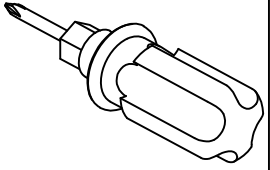
#20	x1
	

ASSEMBLY INSTRUCTIONS

STEP-12

1. Use screw #6 to attach middle door (I) to pre-assemble unit at step 11, tighten screw #6 with screwdriver #20.

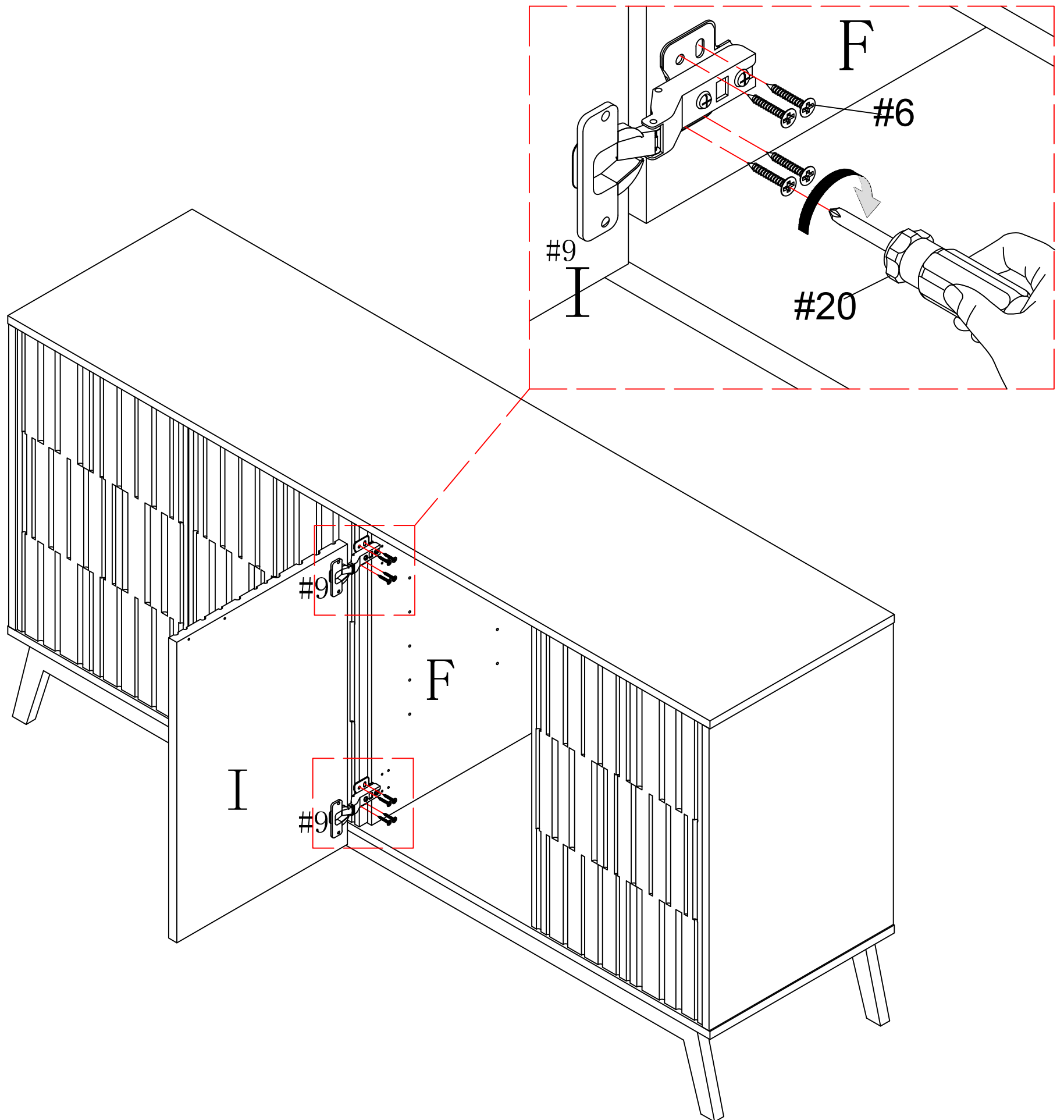

#6	x8
	
Ø3.5*14mm	

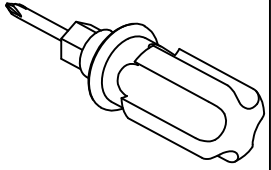
#20	x1
	

ASSEMBLY INSTRUCTIONS

STEP-13

1. Use bolt #6 to attach handle #12 to door panel (I), tighten bolts #6 with screwdriver #20.

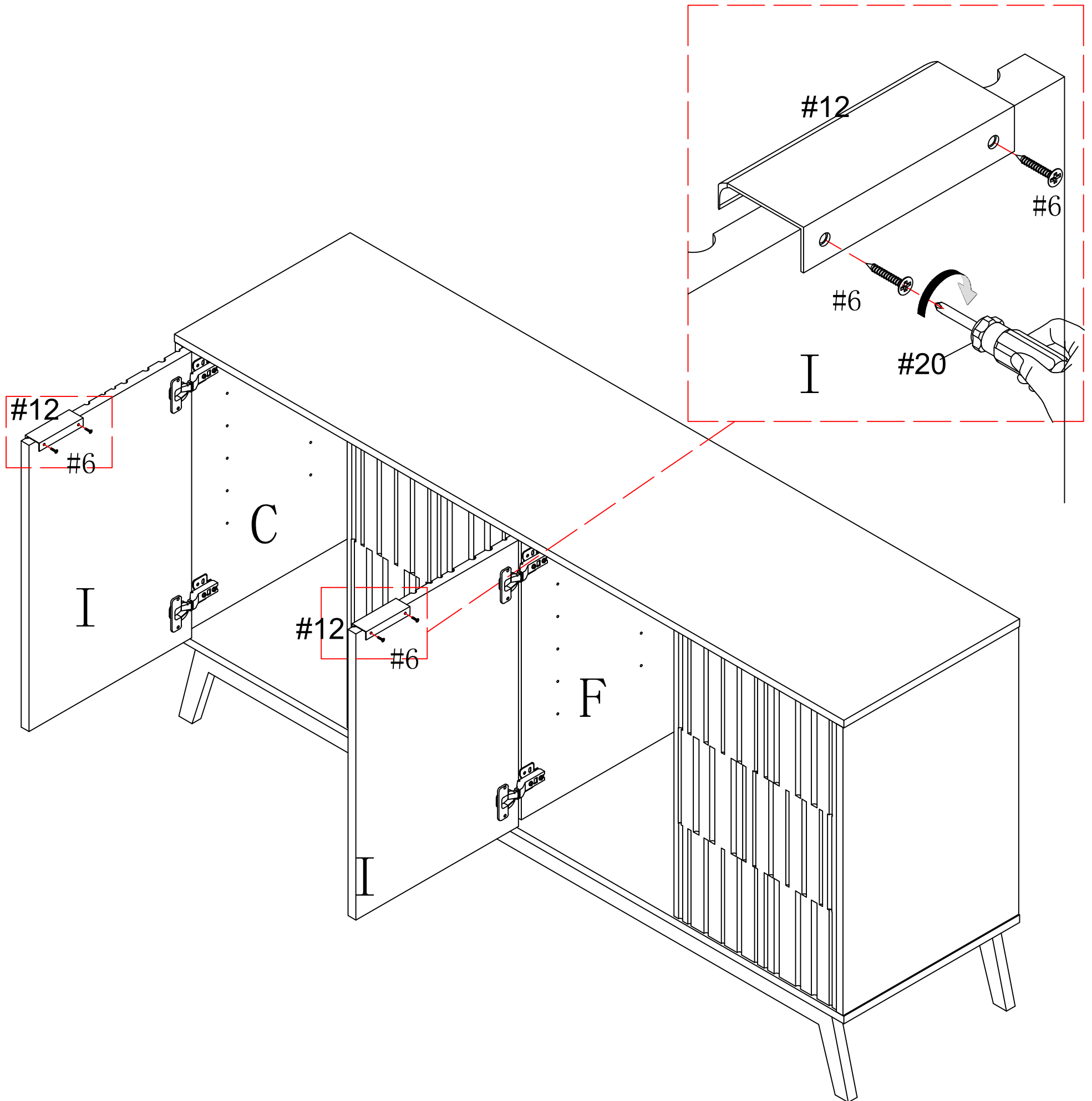

#6	x4
	
Ø3.5*14mm	

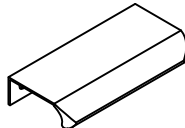
#12	x2
	

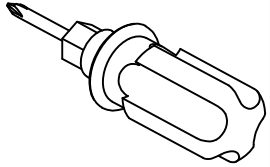
#20	x1
	

ASSEMBLY INSTRUCTIONS

STEP-14

1. Use bolt #6 to attach handle #12 to door panel (J), tighten bolts #6 with screwdriver #20.

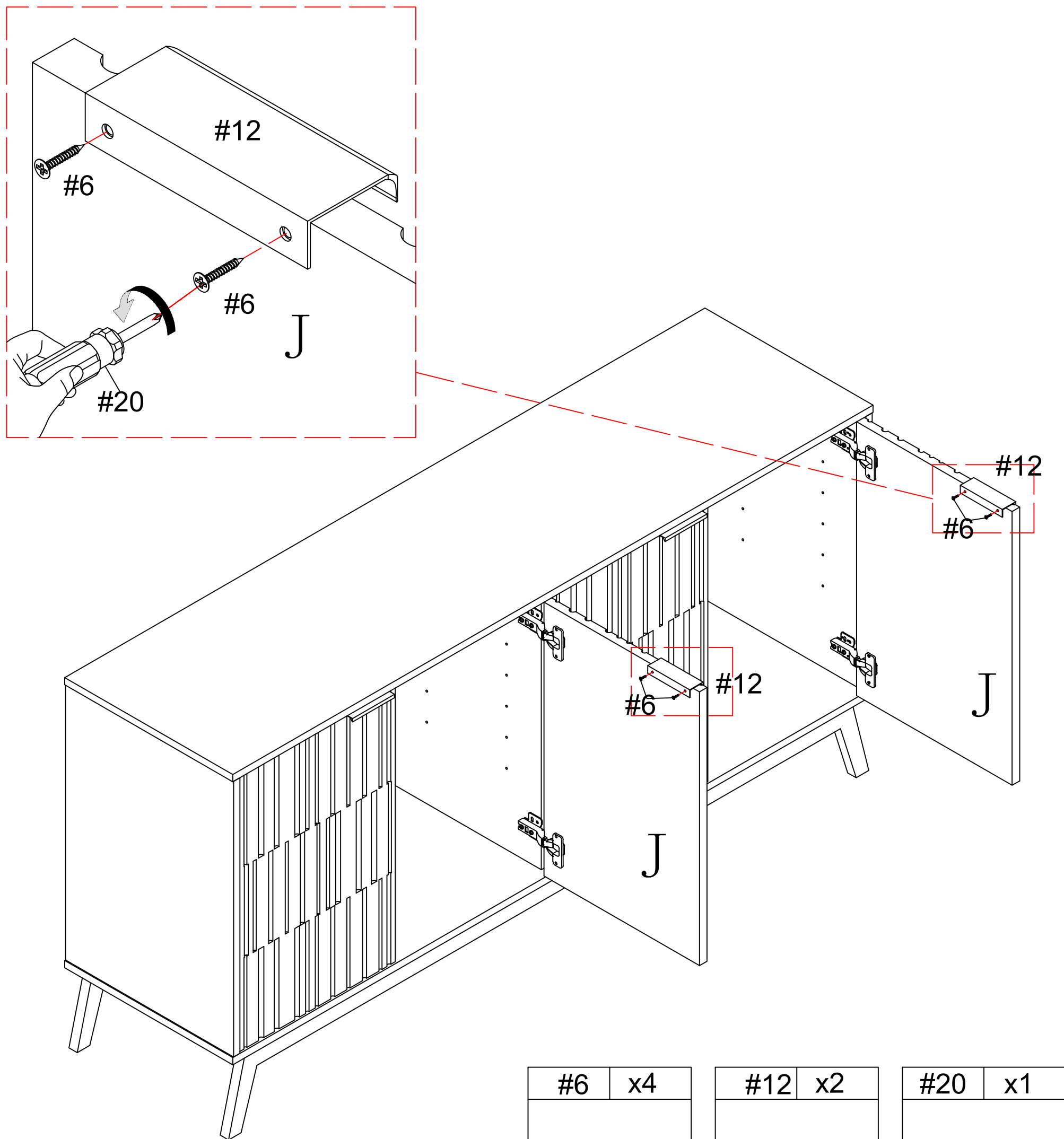

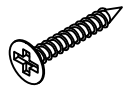
#6	x4
	
Ø3.5*14mm	

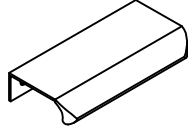
#12	x2
	

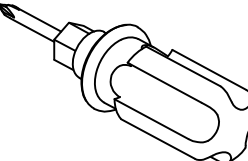
#20	x1
	

ASSEMBLY INSTRUCTIONS

STEP-15

1. Insert shelf pin #14 into pre-assemble unit at step 16.
attach adjustable shelf G&H to pin #14.

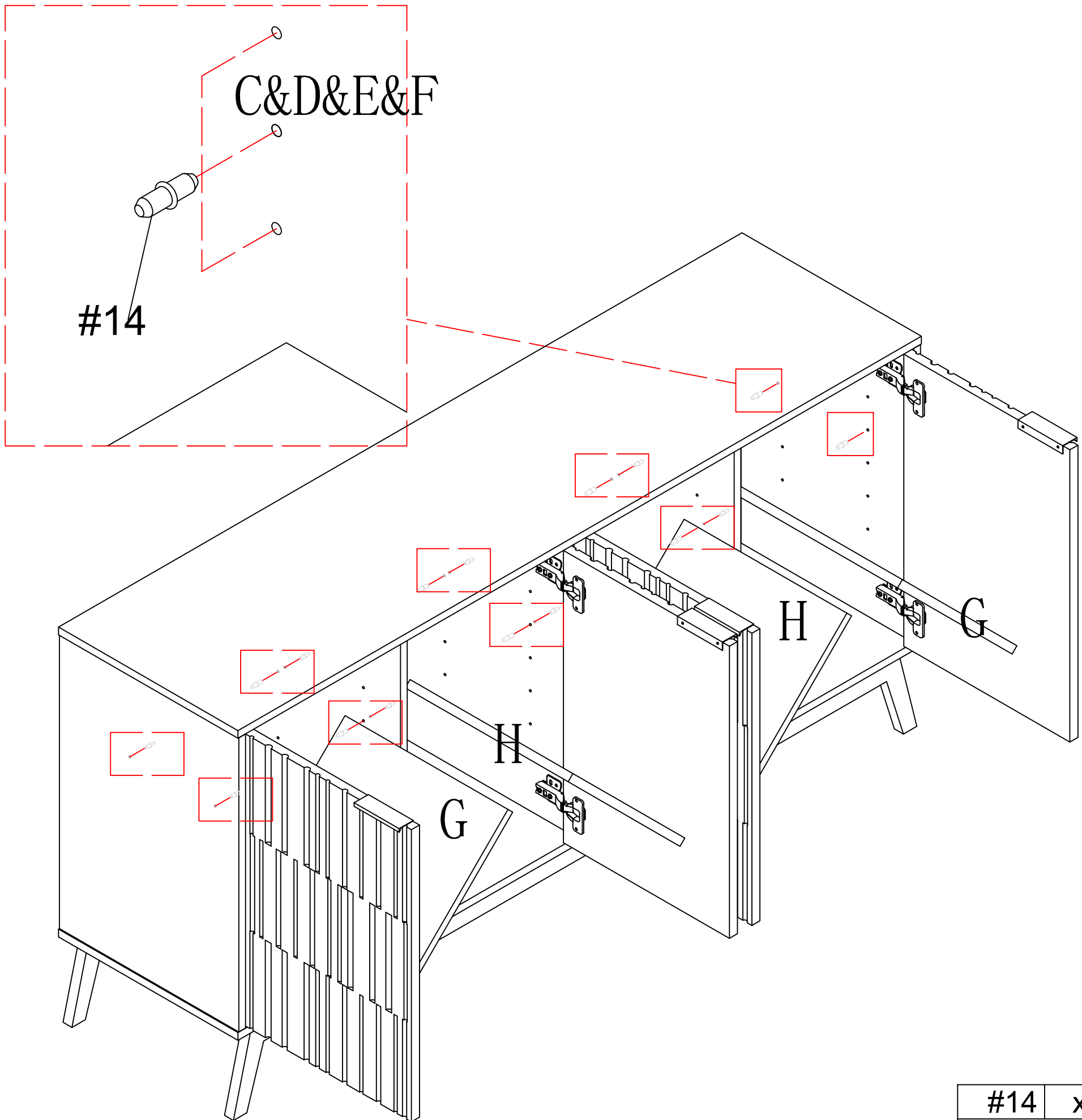

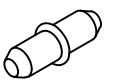
#14	x16
	

ASSEMBLY INSTRUCTIONS

STEP-16

Concealed hinges are three-way adjustable:

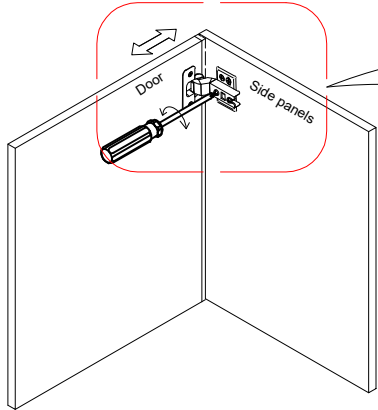

Horizontal
by screw adjustment!

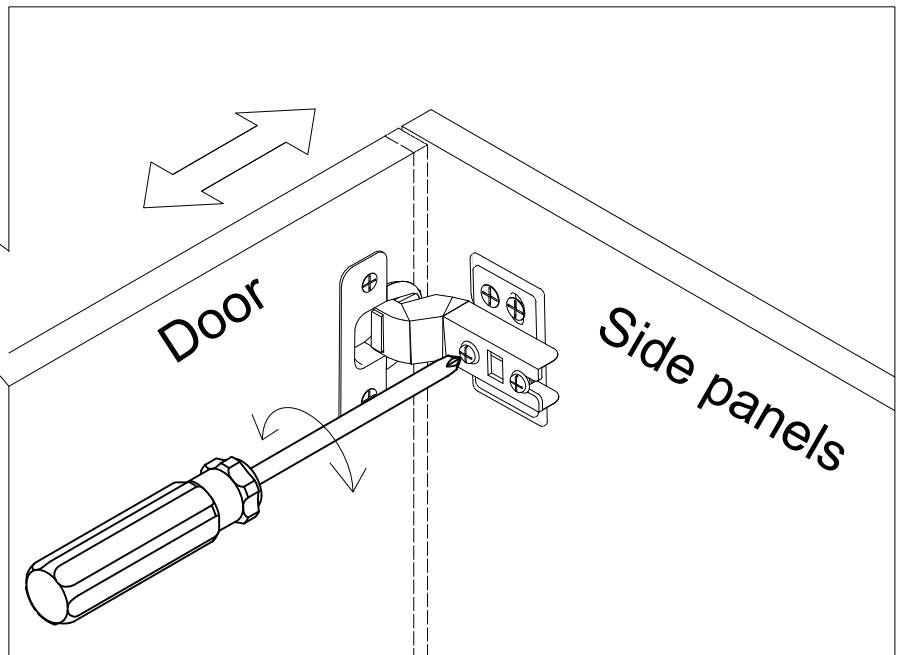

Concealed hinges are three-way adjustable:

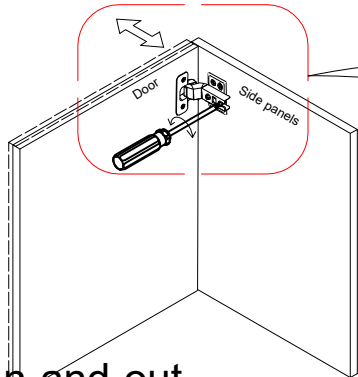

In-and-out
by loosening the hinge arm
mounting screw or via cam
adjustment!

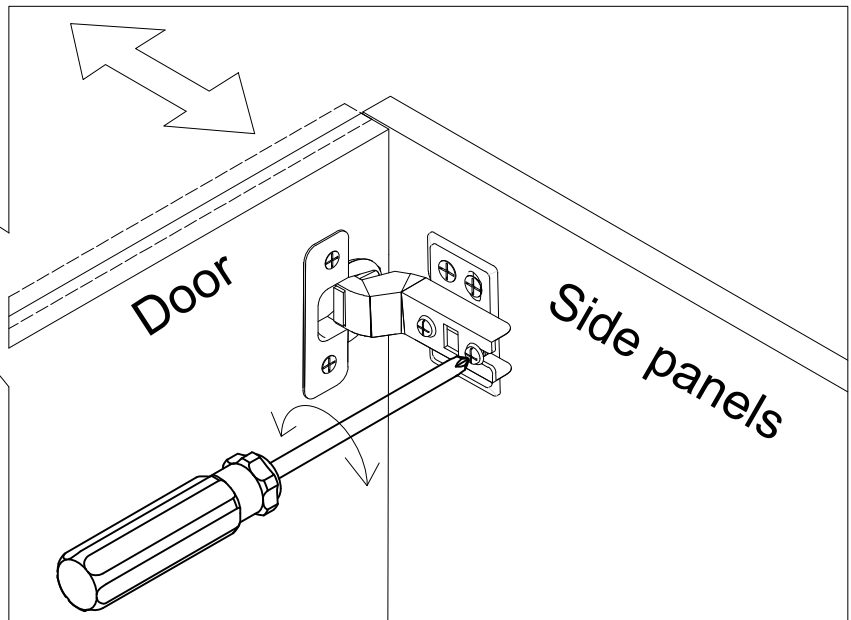

Concealed hinges are three-way adjustable:

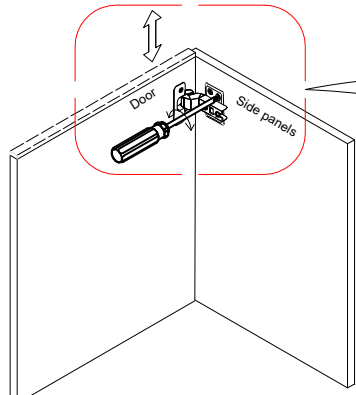

Vertical via slots in
the mounting plate
or via cam adjustment!

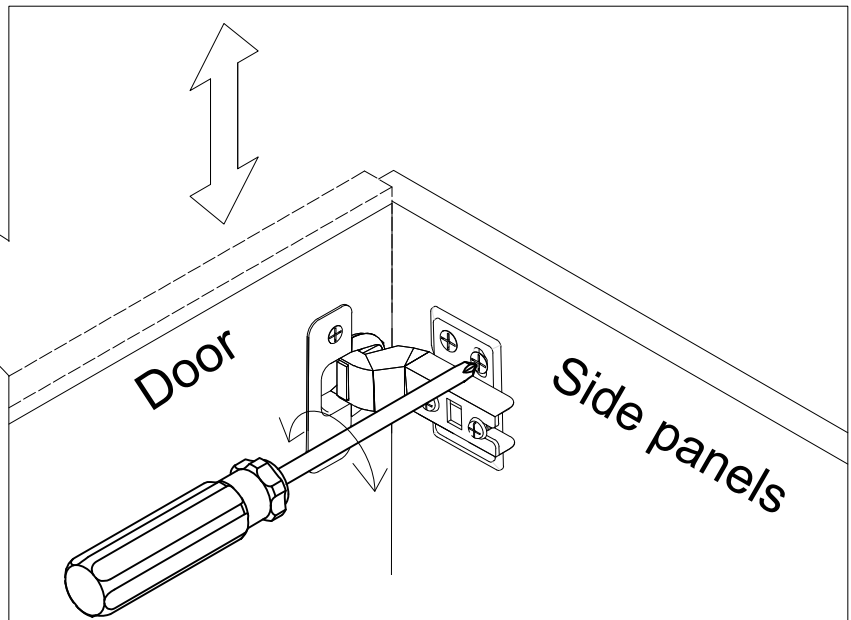

Hinge adjustment method

ASSEMBLY INSTRUCTIONS

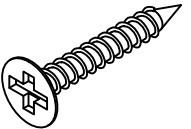
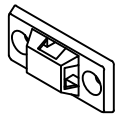
#6	x4	#16	x2
			
Ø3.5 *14mm			

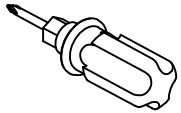
#20	x1
	

STEP-17

1. Use screw #6 to attach part #16 to pre-assemble unit at step 18, tighten screws with screwdriver #20.

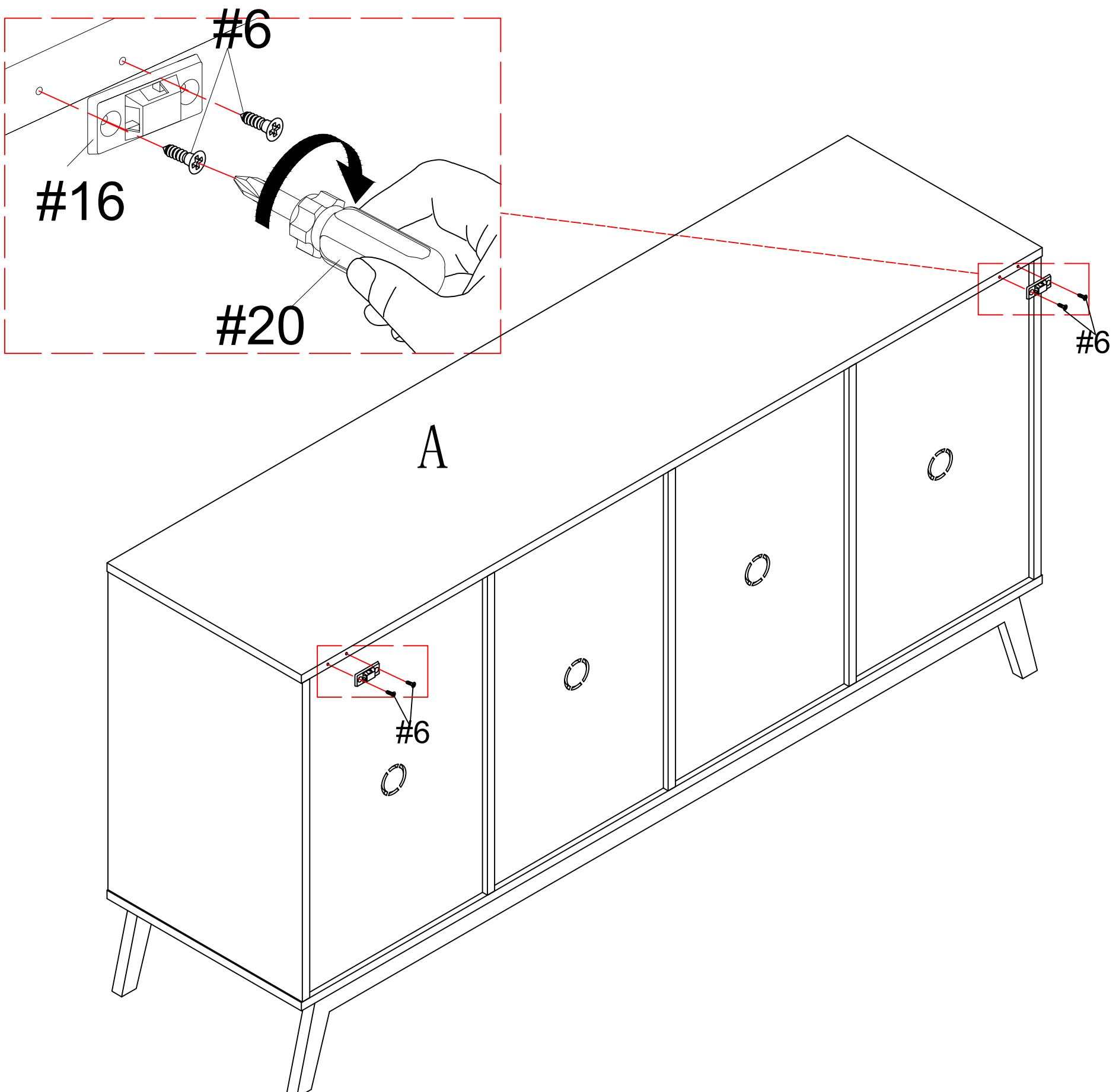

ASSEMBLY INSTRUCTIONS

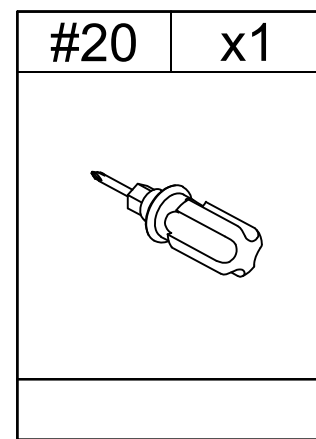
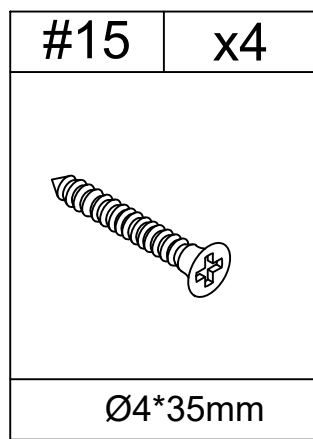
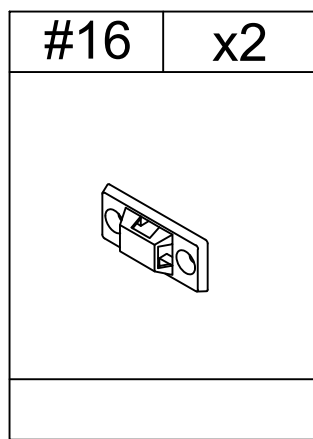
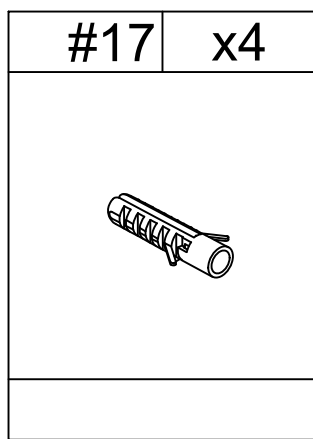

STEP-18

1. Install the anti-collapse device.

2. Mark the position on the wall, that corresponds to the location of part #16 on the of panel (A); Drill and insert the expandable screw #17 by hammer.

3. Assemble the part #16 to the wall. Align the hole in the part #16 with the expandable screw #17, use screw #15 to attach it and tighten by screwdriver #20.

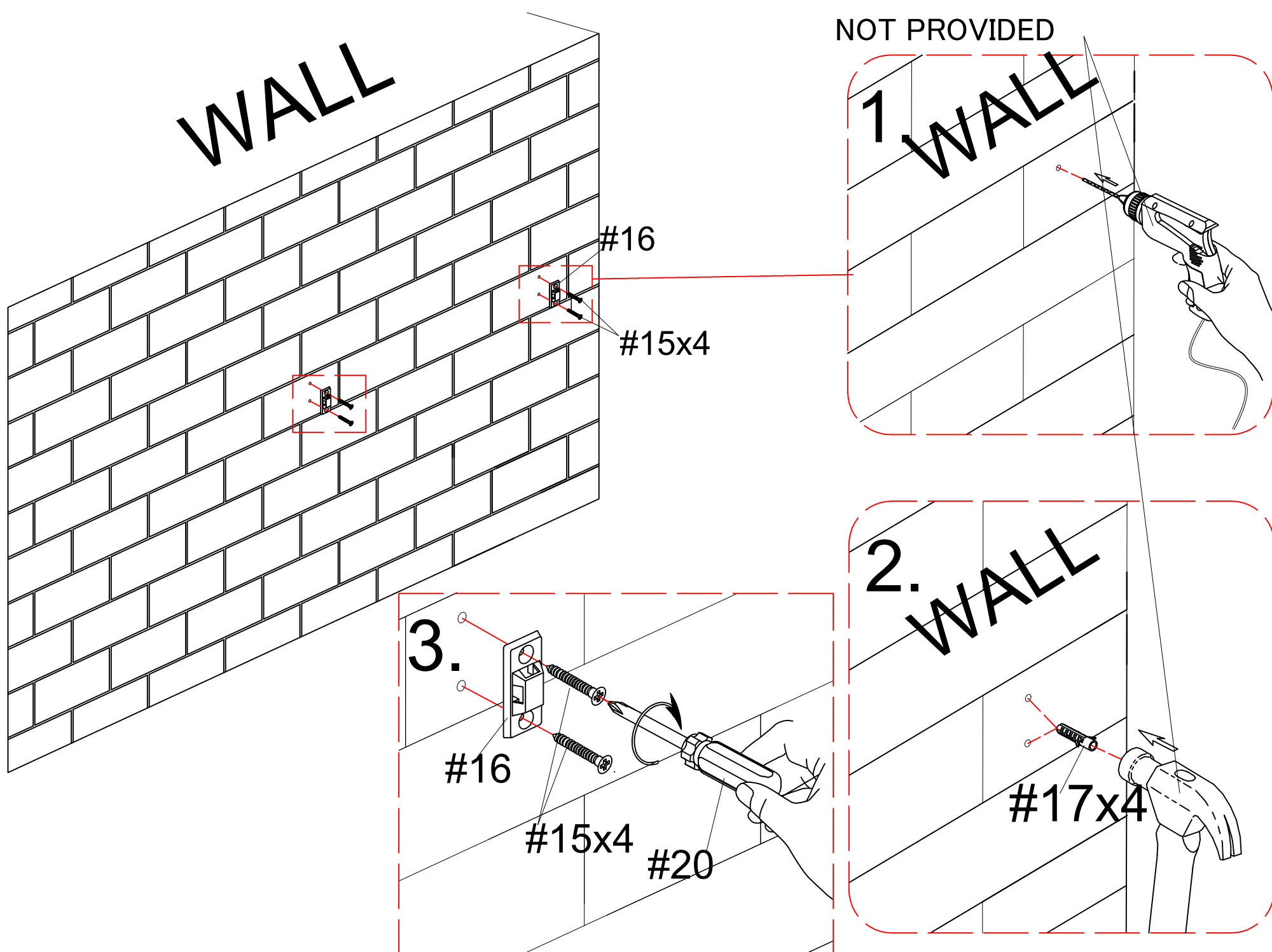

ASSEMBLY INSTRUCTIONS

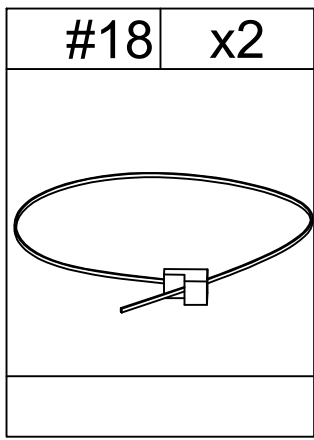

STEP-19

1. Let the plastic belt #18 pass through the both part #16 and pull tightly.

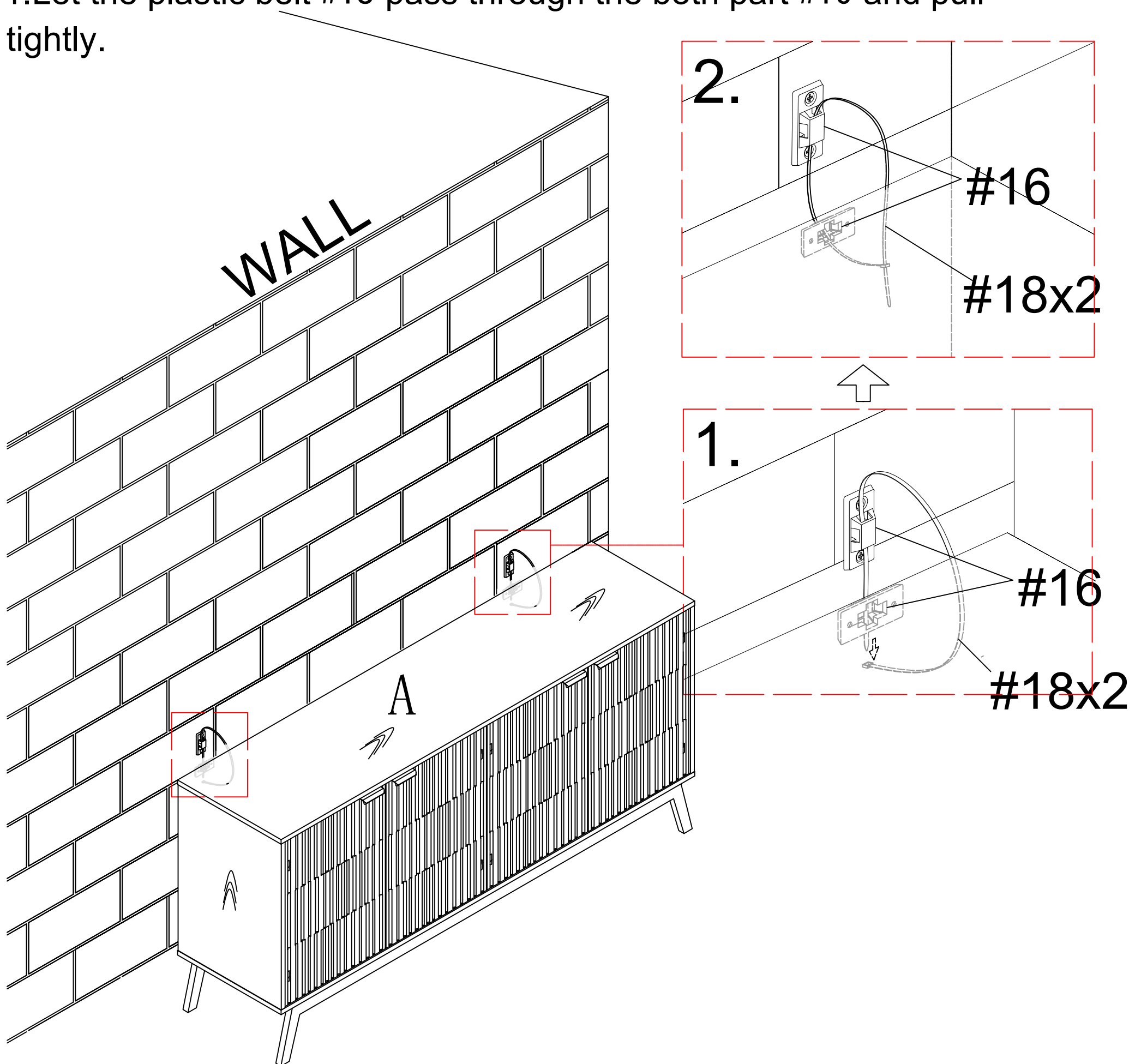

WARRANTY

1. We strive to offer high-quality products, and we also try our best to satisfy each and every customer that orders from us with product or service as needed.
2. We provide 30 days warranty starting from the time you receive the item. Each customer must provide a record of their order such as the order number, or item receipt for any items that are out of the warranty period you may also still receive.
3. Replacement parts by purchasing them with our company if they are available.