

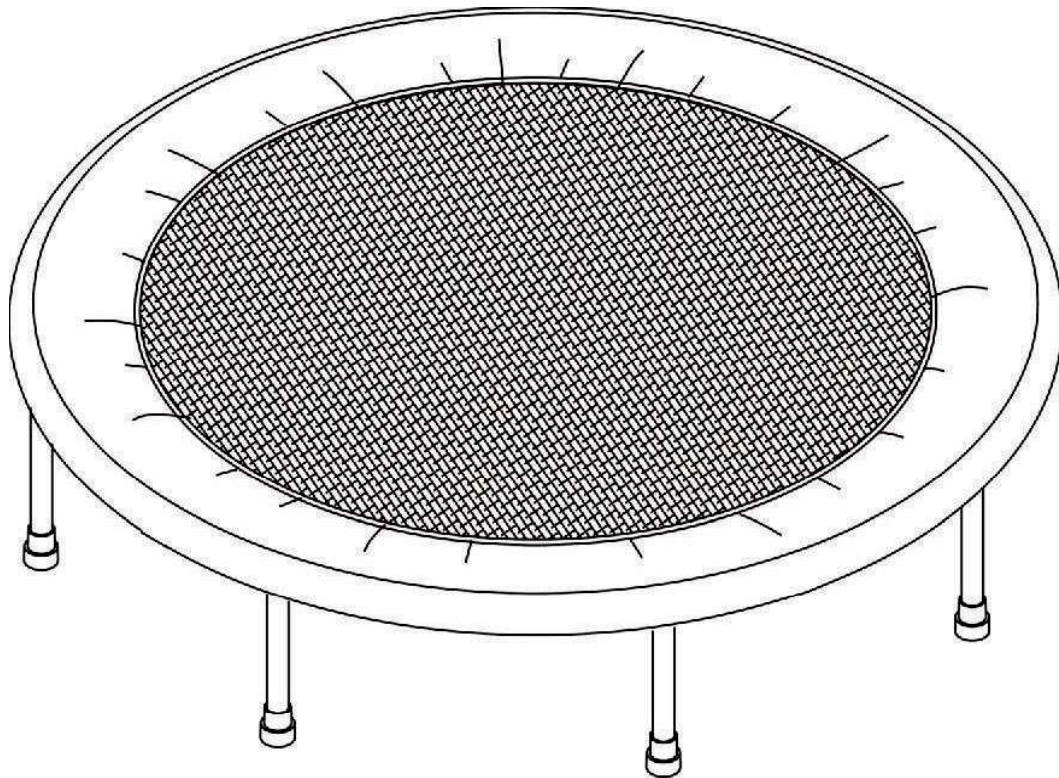

Trampoline User Manual

Assembly, Installation, Care, Maintenance and Use Instructions.

WARNING: Read these materials prior to assembling and using this trampoline.



Model
UBSF014F-36
UBSF014F-40

Manual Version #03



USA

UK



Call us

1-888-965-3331

020-3150-0484



Email us

support@upperbounce.com

support@upperbounce.co.uk



Check out our website

www.upperbounce.com

THANK YOU FOR PURCHASING THE UPPER BOUNCE® TRAMPOLINE

Simply follow the assembly and safety instructions in this manual and you will soon be starting your UPPER BOUNCE® exercise program for a happier, healthier and more fun lifestyle!

Should you have any questions, please call our Customer Service Department
Toll-free number: 1-888-965-3331

MONDAY - THURSDAY 9:30 A.M. - 5:00 P.M. Eastern Time.	FRIDAY 9:00 A.M. - 12:00 P.M. Eastern Time.
--	--

TABLE OF CONTENTS

	Page
Instructions, Proper Assembly & Use, Safety Tips, Warnings	3-6
Trampoline Frame Parts List	7
How to Open the Folding Trampoline	8-11
How to Close the Folding Trampoline	12-13
Workout Program	14
Warm Up and Cool Down	15
Basic Workout	16-17

GENERAL INSTRUCTIONS

Included in this manual are instructions for: Proper assembly, care and maintenance of product, safety tips, warnings, and proper use; in order to ensure a secure and fun use of the trampoline. All users and supervisors must read and familiarize themselves with all these instructions and all other information in this manual.

As with any type of recreational physical activity, without being careful participants can be injured. Anybody who chooses to use this trampoline must be aware of their own limitations in regards to performing various jumps and bounces with this trampoline. Trampolines are rebounding devices which propel the performer to unaccustomed heights through a variety of movements, so initially; you should get accustomed to the feel and bounce of the trampoline. The focus must be on your body position, and you should practice each fundamental bounce until you can do each bounce with skill before moving on to more difficult and advanced bounces. Do not behave recklessly on the trampoline, emphasis must be made on good control and the mastering of various bounce techniques.

Proper Assembly

- The assembly of the product must be done carefully by at least two able-bodied adults. Contact us, or ask any technically qualified person if you have any difficulties.
- Beware that when using tools or doing technical work, there is always a risk of injury, so assemble the product carefully, and use gloves to protect your hands.
- Remove all packaging materials and lay down all parts on a free space. This gives you an overview and simplifies the assembly procedure. Check with the parts list that no parts are missing and dispose of the packaging material when the assembly is completed.
- Work in a danger free environment, do not leave tools or hazardous materials scattered around the workspace.
- Place trampoline on level and non-slippery ground, preferably on grass. Locating the trampoline on a hard surface will add stress to the frame and over time cause damage which is not covered by warranty. Placing the trampoline on uneven surfaces could result in the trampoline tipping over.
- A clearance space of at least 24ft is necessary above the trampoline. An appropriated clearance must be kept between the trampoline and possible sources of danger, such as electric cables, tree branches, playing devices, swimming pools and fences.
- After assembling the trampoline according to the instructions, please make sure that all screws, bolts and nuts are correctly installed and tightened, and that all joints are tightly sealed.
- For additional stability you can place sand bags on the trampoline legs. This will prevent the trampoline from tipping over in the event of any sideward force.

- Never set up the trampoline in rainy, windy or stormy conditions, especially lightening conditions. It is recommended that the trampoline be taken apart and stored in bad weather.
- Do not alter the product; use it only as described in this manual.

Care and Maintenance

- Always inspect the trampoline before each use. Check for damage, wear or defective parts, as they can impair the overall safety of the trampoline. The damaged, worn, or defective parts should be replaced immediately. In the meantime access to the trampoline must be restricted.
- Use the trampoline only in a well-lit area.
- Do not place any objects under the trampoline.
- Repairs should only be carried out by qualified technicians, using only original spare parts. Improper repairs can compromise the safety of your trampoline.
- Strong winds can compromise the stability of the trampoline. If strong winds are predicted, the trampoline must be fastened to the ground with cords and moorings, moved to a protected place, or taken apart and stored.
- Always store your Upper Bounce folding trampoline indoors and in a dry location.
- Store your Upper Bounce folding trampoline in a secure location to guard against unauthorized and unsupervised use.
- The trampoline can only be used if the jumping mat is clean and dry. Worn or damaged jumping mats should be replaced immediately.

Safety Guidelines

To reduce the risk of injury, please carefully read and follow the appropriate safety rules and tips, implementing all safety rules at all times.

- The product is intended for home/domestic use only and is not suitable for professional or medical uses.
- No more than one person at a time is allowed on the trampoline! Multiple jumpers increase the risk of mid-air collisions resulting in injury.

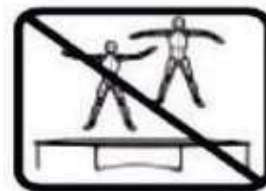

- Do not perform somersaults on the trampoline as this will increase the chances of landing on your head or neck, paralysis or even death can result.
- Children do not recognize the potential dangers of this product, so do not allow your children to play on this product without adult supervision.
- Trampolines over 51 cm (20") in height are not recommended for children under 6 years of age.

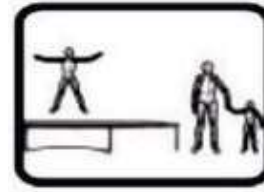
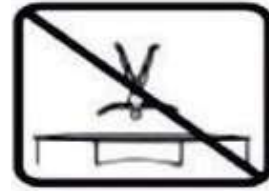

Warnings

- Secure the trampoline against unauthorized use.
- Do not use during pregnancy or if suffering from high blood pressure.
- Do not smoke on the trampoline or use the trampoline when under the influence of alcohol or drugs (incl. Medication).
- Protect the product against humidity and high temperatures.
- Do not put cigarettes, pets, sharp objects or any other foreign objects on the trampoline.



- Do not expose the trampoline to open flames.
- The metal frame of the trampoline will conduct electricity. Lighting, extension cords and all electrical equipment must never be allowed to come in to contact with the trampoline parts.
- The trampoline may not be used in the close vicinity of other leisure devices and constructions.
- Do not allow anyone or any object to go under the trampoline while someone is jumping on the mat. The jumping mat is flexible and the downward force created by someone jumping can cause serious injuries.

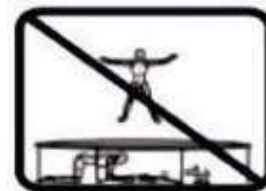







- Take care to keep the packaging materials beyond children's reach, as they present a choking hazard.

Proper Use

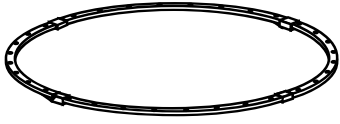
- The maximum weight allowed on the trampoline is 250 pounds. Overloading the trampoline above the recommended user weight will cause damage to the trampoline.
- No more than one person at a time should be allowed on the trampoline!
- Avoid unsupervised use of the trampoline.
- Do not use the trampoline if it is wet.
- Excellent traction is a must when mounting, using and dismounting the Upper Bounce folding trampoline. Bare feet are acceptable, but we recommend wearing high quality footwear with rubber non-skid soles such as walking, running or cross-training shoes.
- Do not sit or lean on the cover pad as it needs to be flexible so it can move with the jumping mat.
- Objects that could be dangerous should be vacated from the playing area.
- Do not allow small children to pull themselves up onto the trampoline by using the cover pads, as this may damage the pads and compromise the safety of your trampoline.
- Do not wear clothes with hooks or loose parts when jumping on the trampoline, in order to avoid getting stuck in any trampoline parts.
- Carefully climb onto trampoline. Do not jump into it directly, or use it as a jump board for other activities. Jumping into the trampoline, hitting the frame, cover pads, and landing incorrectly on the trampoline; can lead to injury.

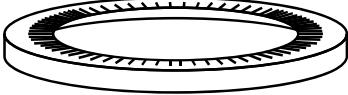
It is the responsibility of the owner or the supervisor to guarantee that all users of the trampoline are informed about all safety rules and that there is sufficient space around the trampoline to allow for safe play.

TRAMPOLINE FRAME PARTS LIST

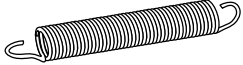
PART #	IMAGE	ITEM	UBSF014F-36	UBSF014F-40
1,2,3,4		Rail A,B,C,D	1	1
5		Mat	1	1
6		Safety Pad	1	1
7		Leg	6	6
8		Leg Cap	6	6
10		Secure Pin	1	1
11		Spring	28	36

Note:

To unfold and fold the trampoline you will need 2 people.

Opening the trampoline requires the application of some pressure. It is strongly suggested that you use 2 people for this part of the process, with one individual on one side of the trampoline and the second on the other side of the trampoline.

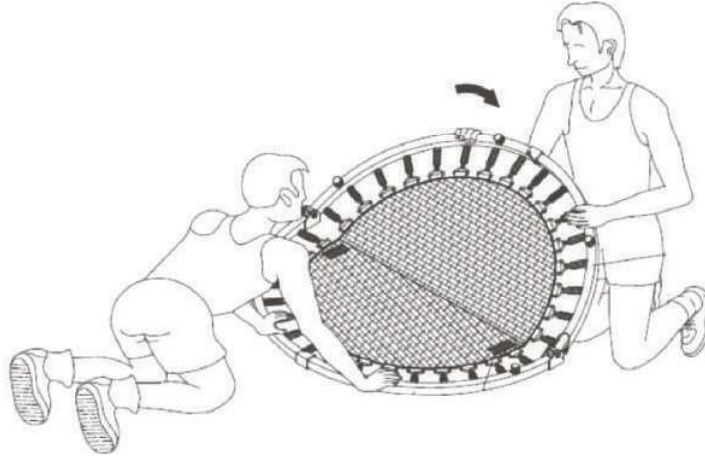

HOW TO OPEN THE UPPER BOUNCE FOLDING TRAMPOLINE

1) Lay the trampoline on the floor and remove the secure pin illustrated in the first picture below. Then open the rails as shown in the picture to the right.

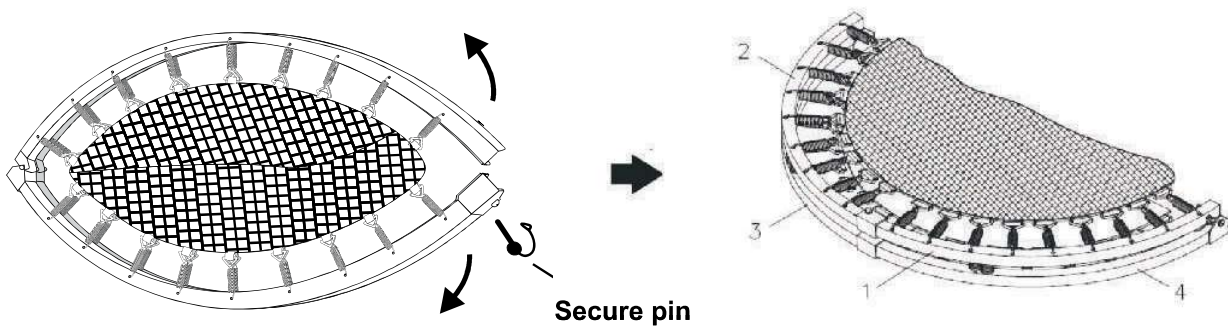

Note: Ensure that all the springs are attached before continuing to assemble the trampoline. If any spring is disconnected or damaged then follow this process:

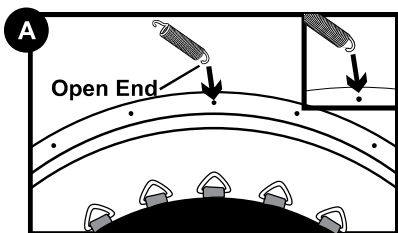

Find the open end of the **SPRING ④** and hook this end into the hole on the **RAIL(1,2,3,4)**. Refer to illustration A.

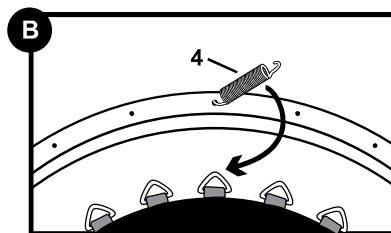

Swing the **SPRING ④** to face inside of the trampoline. Refer to illustration B.

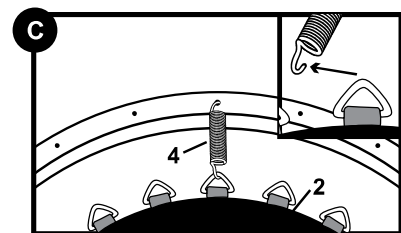

Slide the metal loop on the **MAT ②** into the spring hook as shown in illustration C.

2) Next, firmly grasp both halves of the frame at the midpoint of each half circles.

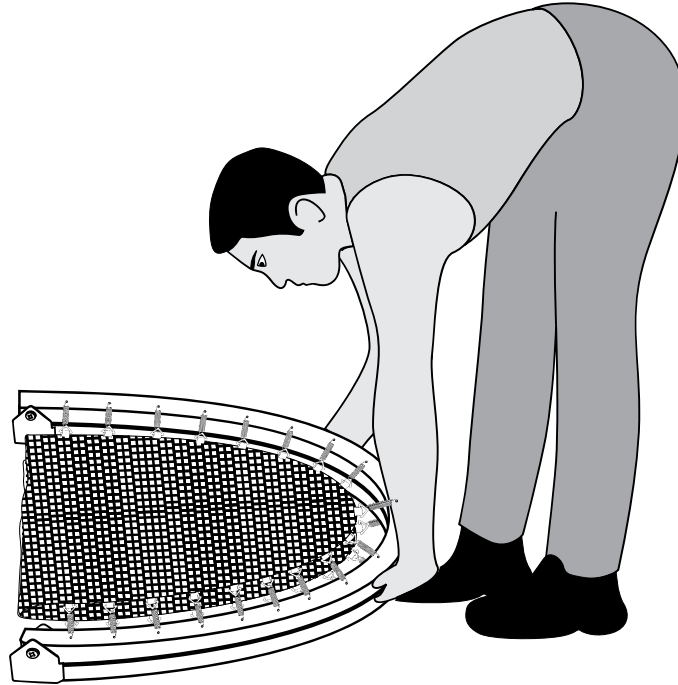

⚠ CAUTION:

When unfolding your new trampoline, you will note a lot of resistance. We design our trampolines in this manner because we do not want them to accidentally fold while in use. This tension will eventually release after repeated use of the product.

3) As one side of the trampoline is lifted slowly upwards, be sure that the other side remains on the ground.

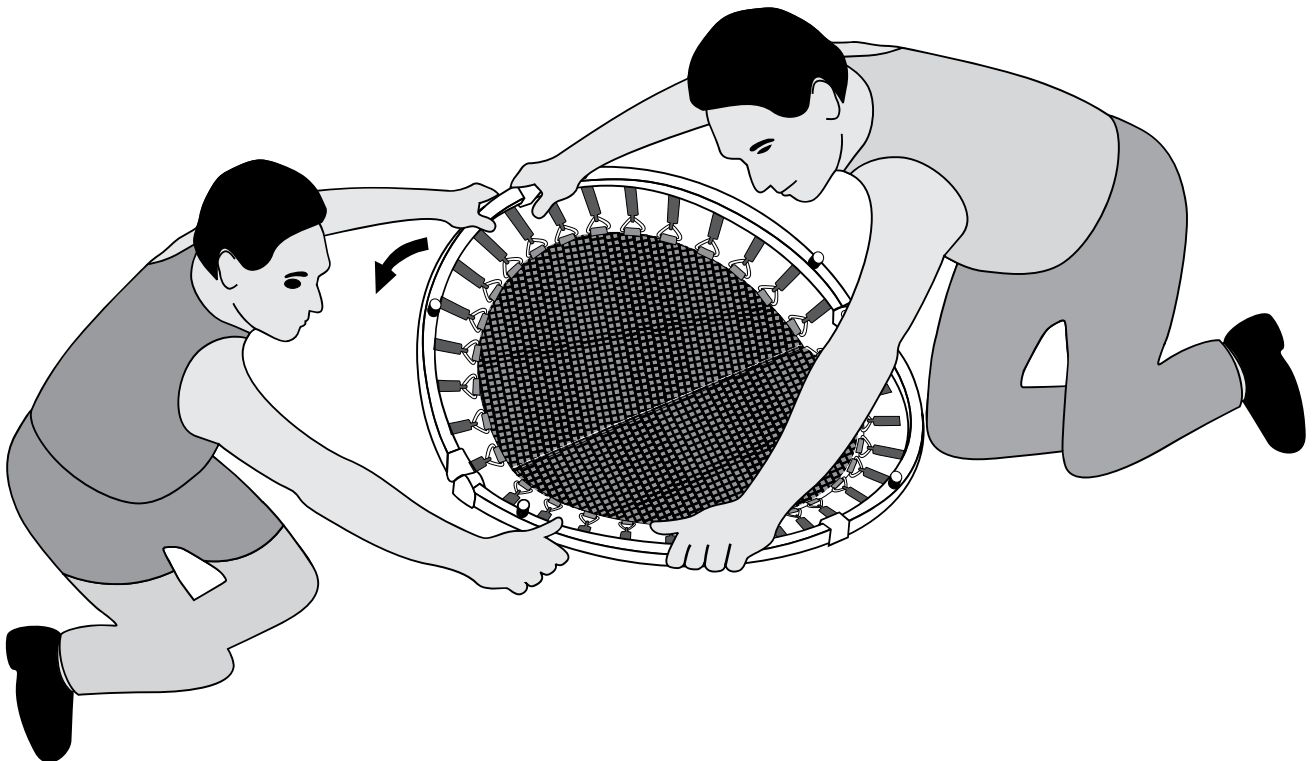

4) Using steady pressure, with hands open and fingers extended, use the palm of the hands to push the top side of the frame down to the open position.

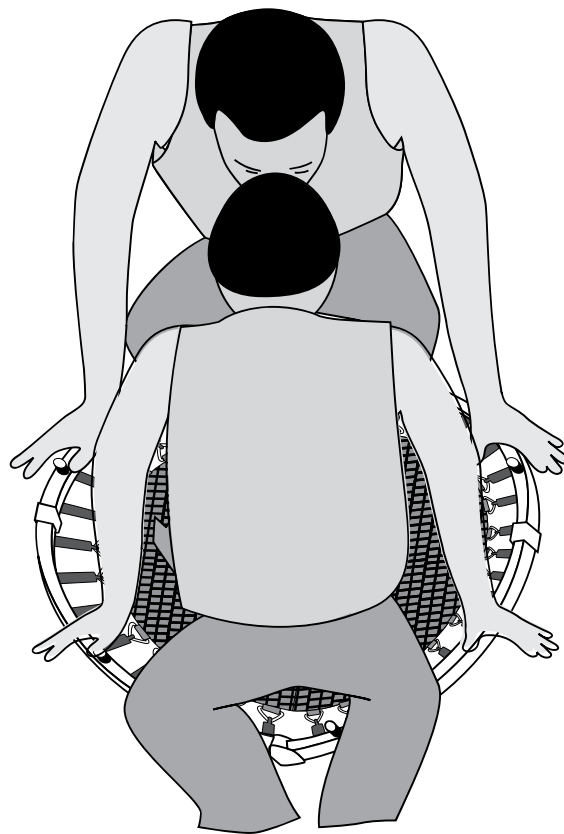

5) Once the frame is completely opened, insert the secure pin (10) into the end of the rail (1) and properly secure it by the wire ring.

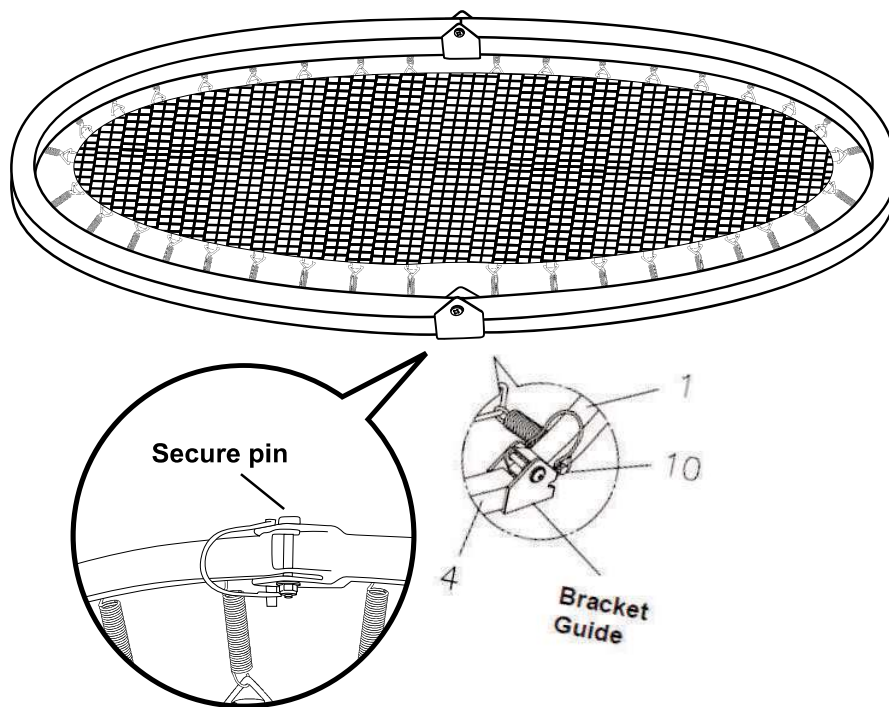

6) Slide the SAFETY PAD(6) over the rails of the frame. Make sure the holes in the SAFETY PAD (6) fit over the threaded leg connectors properly this is on the bottom of the trampoline as shown in the illustration below.

Note: The Safety Pad (6) Must also cover the springs around the MAT (5) as shown in the illustration below.

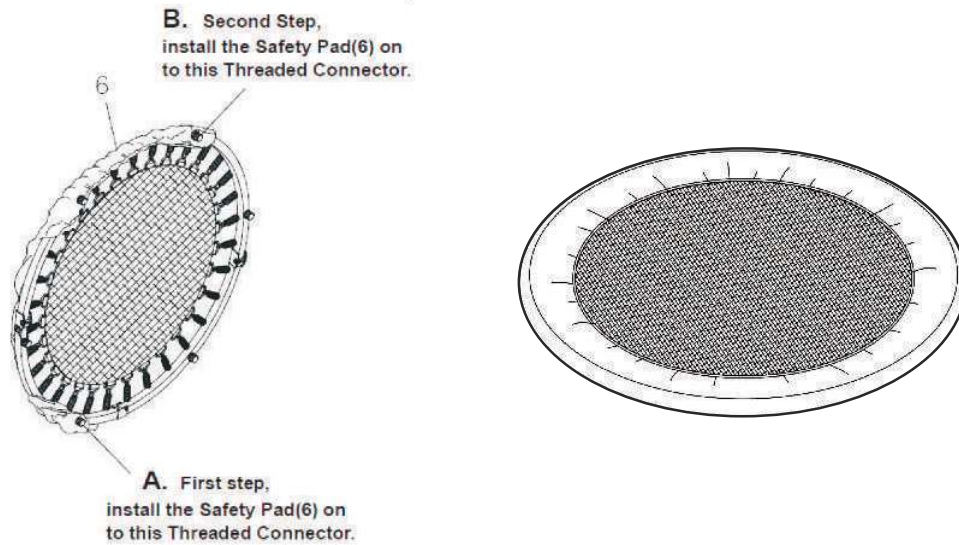

7) Remove the black caps that cover the leg holes. (It is the small threaded pieces that extends from the frame.)

8) Tightly screw the legs into the designed holes - the leg connectors, as shown in the illustration below.

Note:

If you see that one of the legs doesn't have the threads to roll it on the trampoline frame, you will have another small step to do. There is no leg without thread, the only thing is that it might be covered by the rubber cap. So you will need to remove the rubber cap from the trampoline leg, and place it on the opposite side leg- the side without the thread.

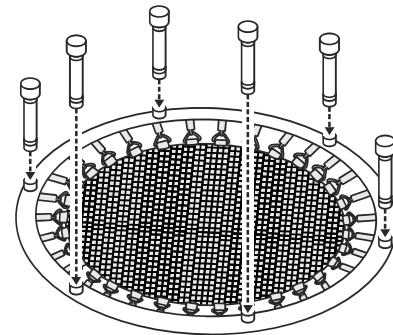

9) Turn the trampoline the right side up. Stand on the trampoline to ensure that the legs stand secure and flat on the floor.

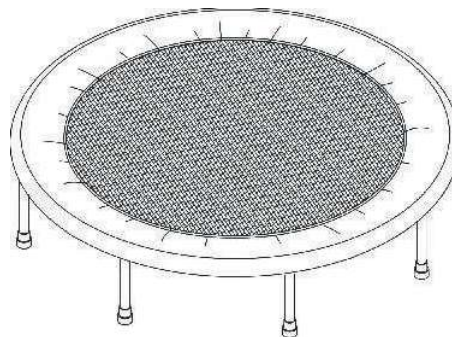

⚠ WARNING:

The Safety Pad ① must be securely attached to the frame before using the trampoline.

HOW TO CLOSE THE UPPER BOUNCE FOLDING TRAMPOLINE

- 1) Turn the trampoline upside down and lay it flat.
- 2) Next unscrew each leg from the threaded connectors in the frame.



⚠ CAUTION

Your Upper Bounce folding trampoline has strong spring tension while in its open position. Upon closing, this powerful spring will have a tendency to snap towards the closed position. It is very important that you follow the instructions and maintain a firm and steady grip. Go slowly while closing your Upper Bounce folding trampoline. Keep your head clear of frame movement.

- 3) Remove the SAFETY PAD(6) from the frame. After the SAFETY PAD(6) is removed, place the trampoline on the floor with the threaded connectors pointing up. Refer to illustration Step 2.

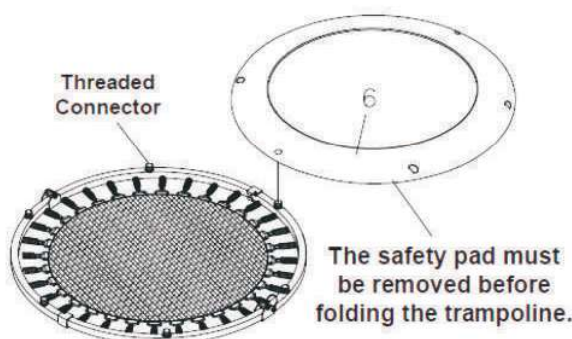

- 4) Determine the bottom half of the frame by locating the side that has the welded, larger outer hinges.

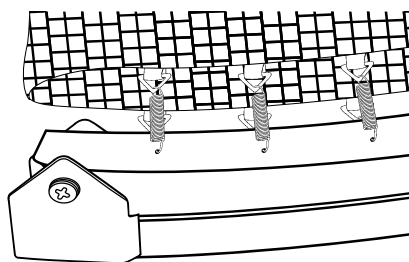

Welded part here

- 5) To prevent the trampoline from snapping into the folded position, push down the rails. Then unhook the wire ring and remove the SECURE PIN (10) from the rail. Firmly grasp both sides of the trampoline and fold the trampoline upward at the bracket guide as shown in the illustration below.

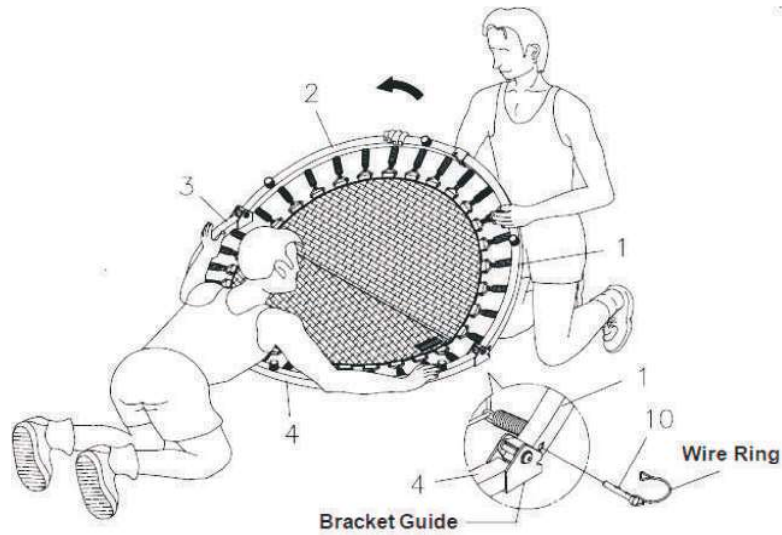

- 6) Fold the trampoline again as shown in illustration Step 5.

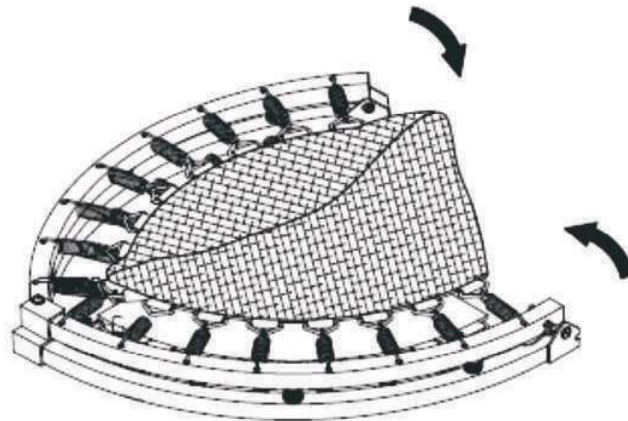

- 7) Insert the secure pin at the end of the frame where the rails connect.

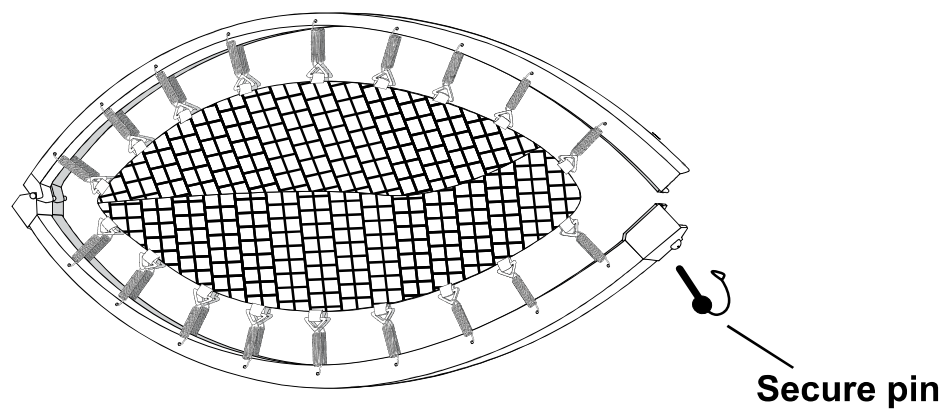

WORKOUT PROGRAM

Stretching Stretching while your muscles are warm after a proper warm-up and again after your strength or aerobic training session is very important. Muscles stretch more easily at these times because of their elevated temperature, which greatly reduces the risk of injury. Stretches should be held for 15 to 30 seconds. Do not bounce.

Suggested Stretching Exercises

(Perform stretches slowly)

Lower Body Stretch

Place feet shoulder-width apart and lean forward. Keep this position for 30 seconds using the body as a natural weight to stretch the backs of the legs. **DO NOT BOUNCE!** When the pull on the back of the legs lessen, try a lower position gradually.

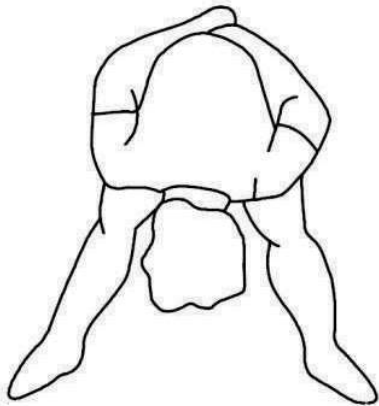

Floor Stretch

While sitting on the floor, open the legs as wide as possible. Stretch the upper body toward the knee on the right leg by using your arms to pull your chest to your thighs. Hold this stretch 10 to 30 seconds. **DO NOT BOUNCE!** Do this stretch 10 times. Repeat the stretch with the left leg.

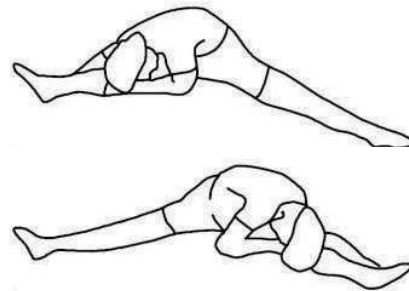

Bent Torso Pulls

While sitting on the floor, have legs apart one leg straight and one knee bent. Pull the chest down to touch the thigh on the leg that is bent and twist at the waist. Hold this position at least 10 seconds. Repeat 10 times on each side.

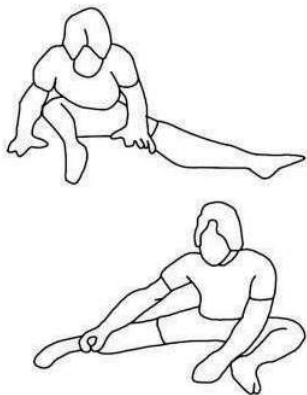

Bent Over Leg Stretch

Stand with feet shoulder width apart and lean forward as illustrated. Using the arms, **gently** pull the upper body towards the right leg. Let the head hang down. **DO NOT BOUNCE!** Hold the position a minimum of 10 seconds. Repeat pulling the upper body to the left leg. Do this stretch several times slowly.

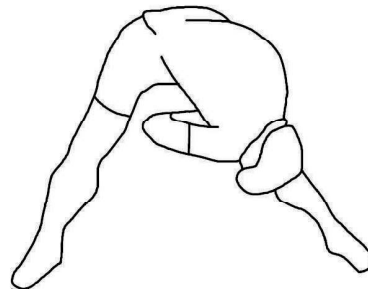

Remember always to check with your physician before starting any exercise program.

WARM-UP AND COOL-DOWN

Warm-Up

The purpose of warming up is to prepare your body for exercise and to minimize injuries. Warm up for two to five minutes before strength-training or aerobic exercising. Perform activities that raise your heart rate and warm the working muscles. Activities may include brisk walking, jogging, jumping jacks, jump rope, and running in place. Below are specific warm-up exercises for the trampoline workout.

Cool-Down

The purpose of cooling down is to return the body to its normal, or near-normal, resting state at the end of each exercise session. A proper cool-down slowly lowers your heart rate and allows blood to return to the heart. Your cool-down should include the previously mentioned stretches and the same warmup exercises listed below.

Warm-Up and Cool-Down Exercises

(Do each movement 10 times)

Contact Bounce

Place your feet shoulder width apart and bend at the knees. Place your hands on your waist. Start bouncing very gently without your feet leaving the mat. This movement is to get you comfortable with being on the mat.

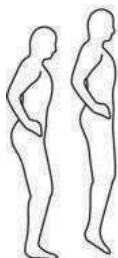

Foot Tap

While in the Contact Bounce position, shift your weight towards the right and tap your left foot out to the side. Bring your left foot back to shoulder width. Shift your weight to the left tap your right foot out to the side. Repeat the movement back and forth.

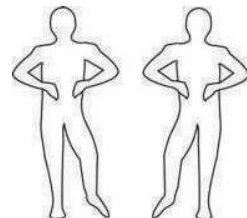

Hamstring Curls

While bouncing, shift your weight to the right and bring your left foot up to your left buttock. Bring your left foot down and shift your weight to the left and bring your right foot up to your right buttock. Repeat the movement back and forth.

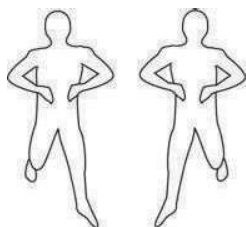

Side To Side

In this movement, place both feet together and bounce from one side of the mat to the other side of the mat. Repeat the movement back and forth.

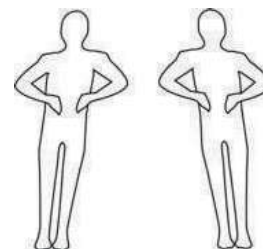

Jog in Place

While standing in the center of the mat, jog in place as you would on the ground.

Jog Bounce

While jogging in place, bounce twice on one leg before switching to the other leg.

BASIC WORKOUT

Basic Workout Exercises (Do each movement 10 times)

Contact Bounce, Big Bounce

Place your feet shoulder-width apart and bend at the knees. Place your hands on your waist. Start bouncing very gently without your feet leaving the mat. On your second bounce, bounce high enough that your feet leave the mat; only bounce as high as you feel comfortable bouncing. Continue to alternate your bounces back and forth. A variation can be done by raising your forearms as if you are doing biceps curls.

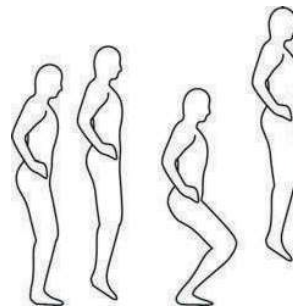

Knee Raises

While in the Contact Bounce position, alternately raise your right and left knees to just above waist height. Repeat the movement back and forth. You can add your own variations to this movement such as raising your arms out to the sides or to the front.

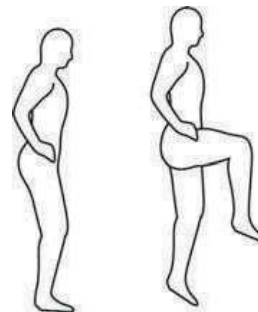

Jumping Jacks

With your feet together in the center of the mat, simultaneously bounce and land with your feet shoulder width apart. At the same, raise your arms out to the sides and overhead. Then, bounce and land with your feet back together and your arms resting at your sides. Repeat the movement.

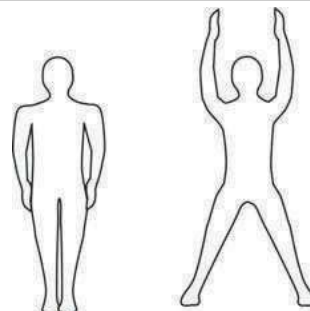

Upright Row

While in the Contact Bounce position, alternately raise your knees to just above waist height. At the same time, perform an upright row with your arms to chin height each time you raise a knee. Repeat the movement.

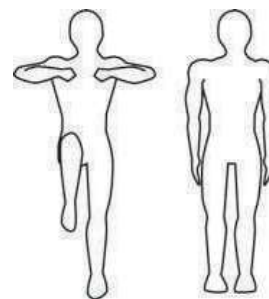

Twist Bounce

With your feet together in the center of the mat bounce and twist your lower body to the right, simultaneously twisting your upper body to the left. Then bounce and twist your lower body to the left, simultaneously twisting your upper body to the right. Repeat the movement.

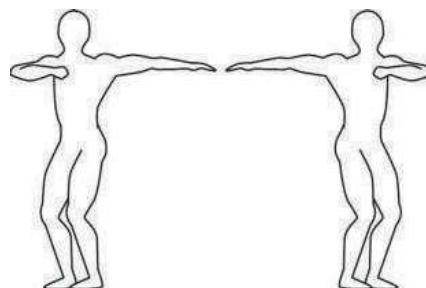

BASIC WORKOUT (continued)

Basic Workout Program

Jogger Warm-Up

Do each exercise 10 times

1. Contact Bounce
2. Foot Tap
3. Hamstring Curls
4. Side to Side
5. Contact Bounce
6. Jog in Place
7. Jog Bounce
8. Jog in Place
9. Contact Bounce

Jogger Cool-Down

Do each exercise 10 times

1. Contact Bounce
2. Jog in Place
3. Jog Bounce
4. Jog in Place
5. Contact Bounce
6. Side to Side
7. Hamstring Curls
8. Foot Tap
9. Contact Bounce

Basic Workout

Do each exercise 10 times

1. Contact Bounce, Big Bounce (Hands on waist)
2. Contact Bounce, Big Bounce (Hands, Triceps/biceps movement)
3. Jog in Place
4. Knee Raises (Hands and Shoulder movement)
5. Jumping Jacks
6. Upright Row
7. Jog in Place
8. Front / Back jumps (Lateral and Forward shoulder raise)
9. Twist Bounce
10. Knee Raises (Hands on waist)
11. Jog in Place



Still have questions?

If you've read this entire manual and still have questions, please do not hesitate to contact us. Our experienced and knowledgeable team is ready to answer all questions that you may have regarding the Upper Bounce folding trampoline.

Please call us **1-888-965-3331**
or email us at **support@upperbounce.com**

We will assist you as quickly and accurately as possible. Our professional customer service team is standing by to help you get the most out of your Upper Bounce folding trampoline.

Thank you for your interest in Upper Bounce and we look forward to helping you achieve your fitness goals.



Need Parts?

We are sure that you and your entire family are having tons of fun and enjoying your trampoline. With continuous use there inevitably might come a time when a part wears out and needs replacement.

We at UPPER BOUNCE are proud to stock a full line of trampoline parts for brand- name and off-brand trampolines. Regardless of where you initially bought your trampoline, or how long ago, we sure have the replacement part you need. As we operate a fully stocked warehouse with every imaginable trampoline part type in the market.

Give us a call and we will do our utmost to ensure that you get your trampoline back up and bouncing quickly and safely.

Website : **www.upperbounce.com**
Knowledge Base : **www.support.upperbounce.com**