

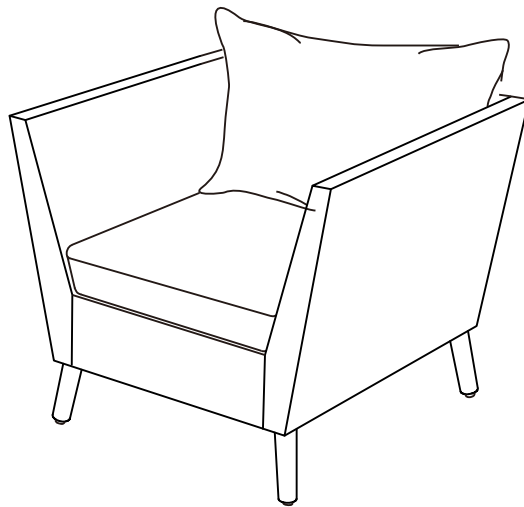

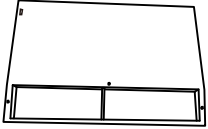

Arm Chair

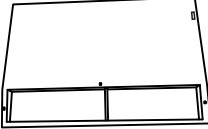
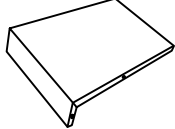
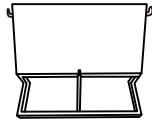
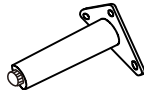
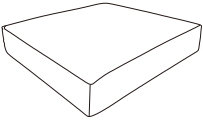
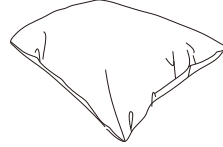

PART LIST

A 	B 	C 	D 	E 
Right Arm Panel 2 PCS	Left Arm Panel 2 PCS	Seat Panel 2 PCS	Back Panel 2 PCS	Leg 8 PCS
F 	G 			
Seat Cushion 2 PCS	Back Cushion 2 PCS			

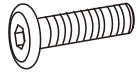
HARDWARE LIST

#1 	#2 	#3 	#4 
M6*15mm Short Bolt 24 PCS (Extra 1)	M6*30mm Long Bolt 14 PCS (Extra 1)	M6mm Flat Washer 38 PCS (Extra 1)	M6mm Allen Wrench 1 PC

Step 1. Lay right arm panel (part A) upside down on a soft flat surface, such as carpet, as shown below. Attach back panel (part D) to right arm panel (part A) using long bolt (part #2), flat washer (part #3) and allen wrench (part #4).

NOTE: Please do not fully tighten bolts until unit is fully assembled.

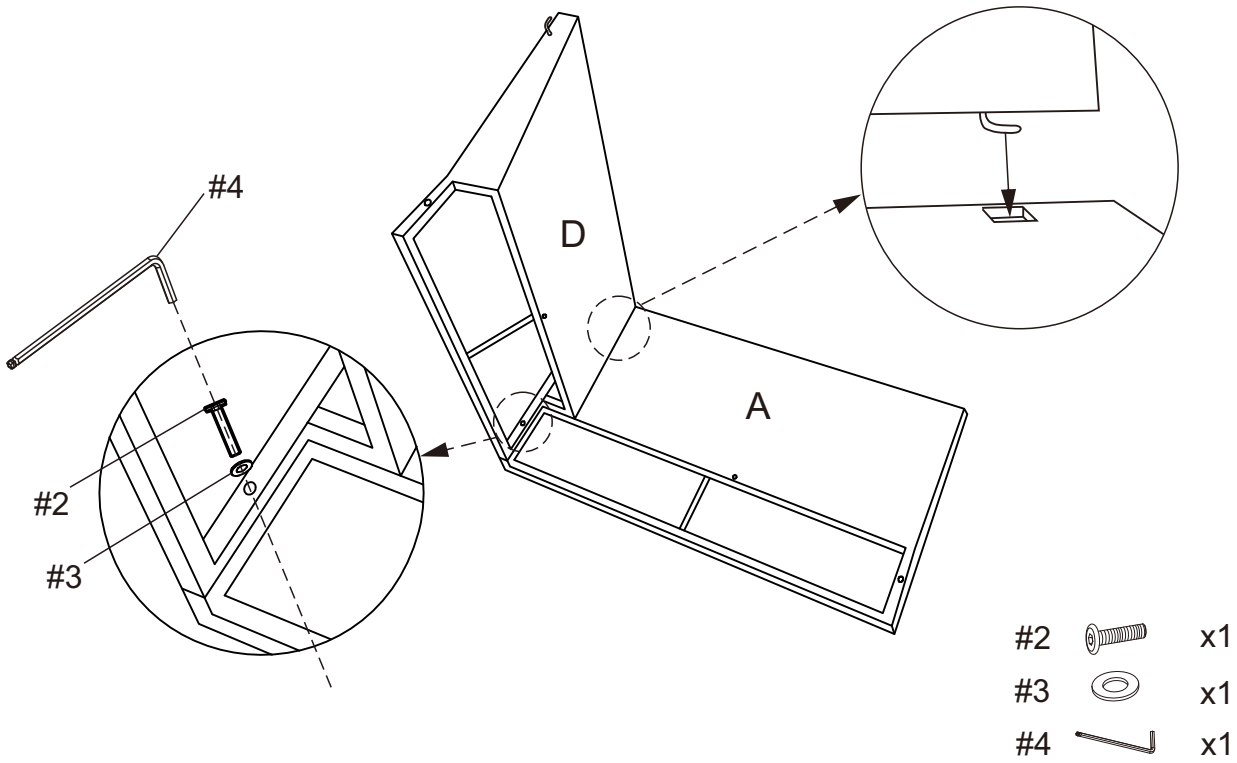

Step 2. Attach seat panel (part C) to right arm panel (part A) and back panel (part D) using long bolts (part #2), flat washers (part #3) and allen wrench (part #4).

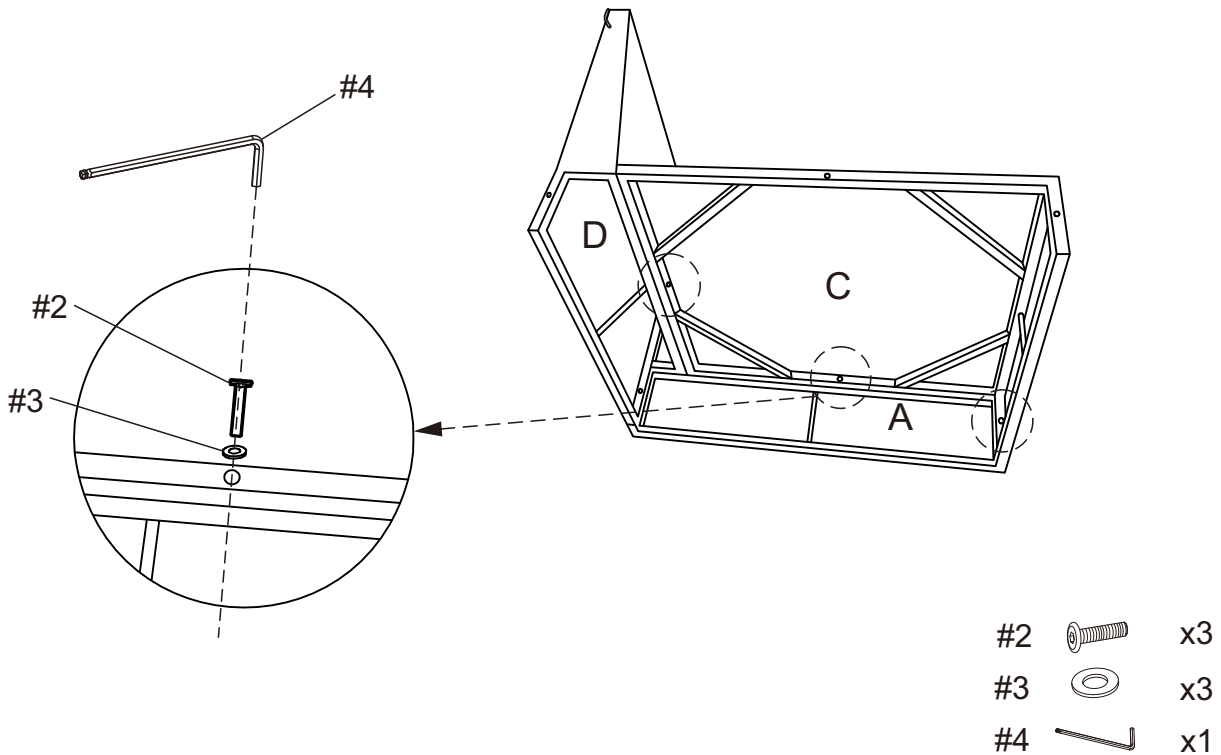

NOTE: Please do not fully tighten bolts until unit is fully assembled.

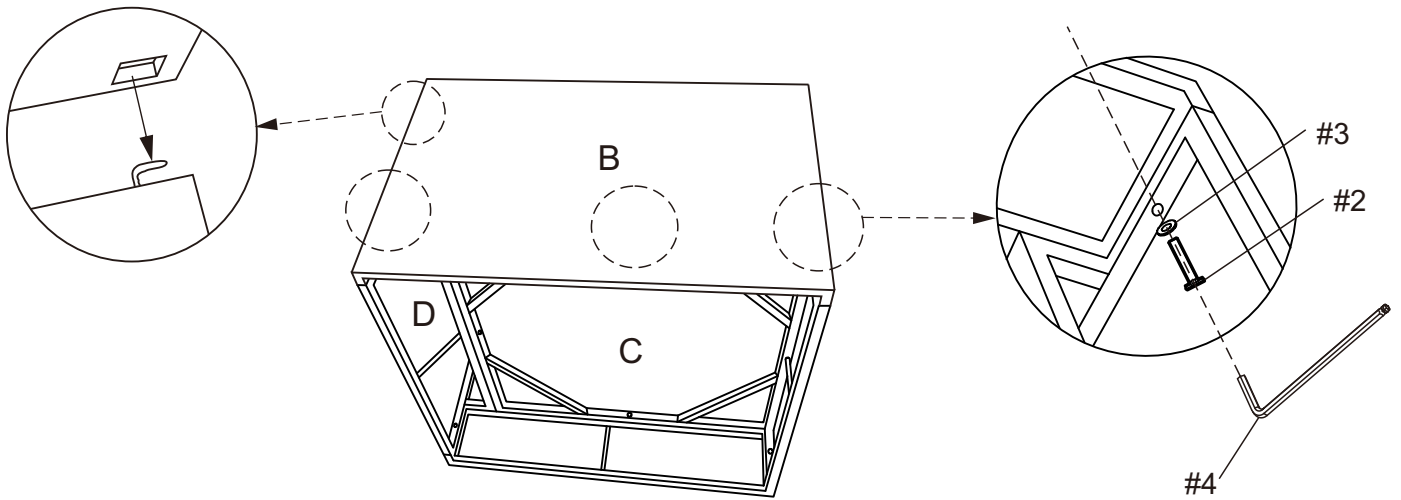

Step 3. Attach left arm panel (part B) to back panel (part D) and seat panel (part C) using long bolts (part #2), flat washers (part #3) and allen wrench (part #4).

NOTE: Please do not fully tighten bolts until unit is fully assembled.





- | | | |
|----|---|----|
| #2 |  | x3 |
| #3 |  | x3 |
| #4 |  | x1 |

Step 4. Carefully turn assembled unit upside down. Attach legs (part E) to assembled unit (parts A, B & D) using short bolts (part #1), flat washers (part #3) and allen wrench (part #4).

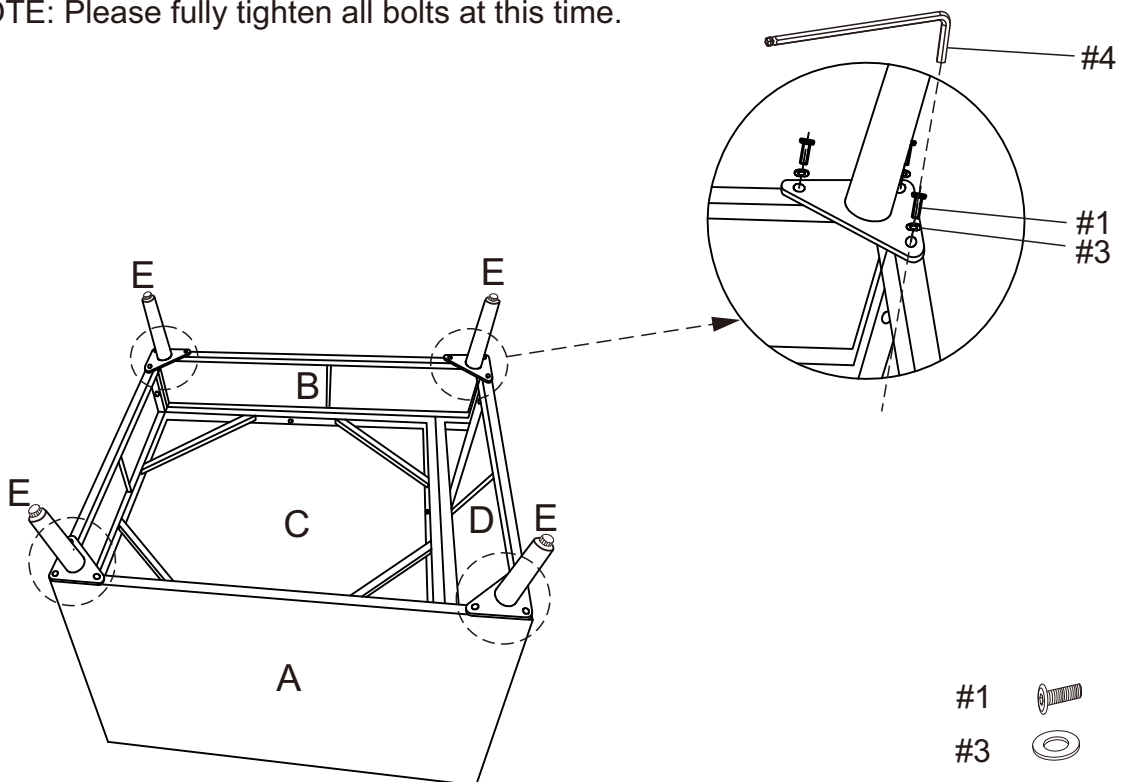
NOTE: Please fully tighten all bolts at this time.



- | | | |
|----|---|-----|
| #1 |  | x12 |
| #3 |  | x12 |
| #4 |  | x1 |

Step 5. Carefully turn unit upright. Add seat cushion (part F) and back cushion (part G) as shown below.
Repeat steps 1-5 to assemble remaining chair.

