

**ASSEMBLY INSTRUCTION**

**ASSEMBLY TIPS:**

- 1.Remove hardware from box and sort by size.
- 2.Please check to see that all hardware and parts are present prior to start of assembly.
- 3.Please follow attached instructions in the same sequence as numbered to assure fast & easy assembly.



**Warning!**

- 1.Don't attempt to repair or modify parts that are broken or defective.Please contact the store immediately.
- 2.This product is for home use only and not intended for commercial establishment.

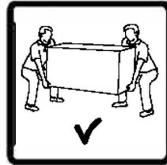

**ASSEMBLY TIME PER UNIT: 40 MINUTES**

**PARTS IDENTIFICATION:**

(A) CROSS PANEL

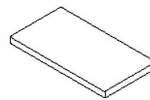

**4PCS**

(B) TOP PANEL

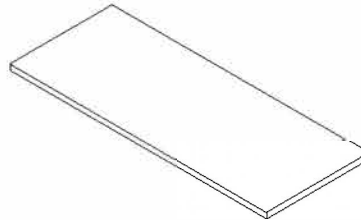

**1PC**

(C) METAL FRAME

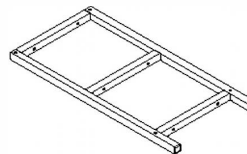

**4PCS**

(D) CROSS BAR

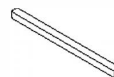

**8PCS**

Z	HARDWARE PACKAGE		
NO	DESCRIPTION	FIGURE	Q'TY
1	BOLT M6x44mm		40PCS
2	ALLEN WRENCH		1PC

# ASSEMBLY INSTRUCTION

STEP 1 :

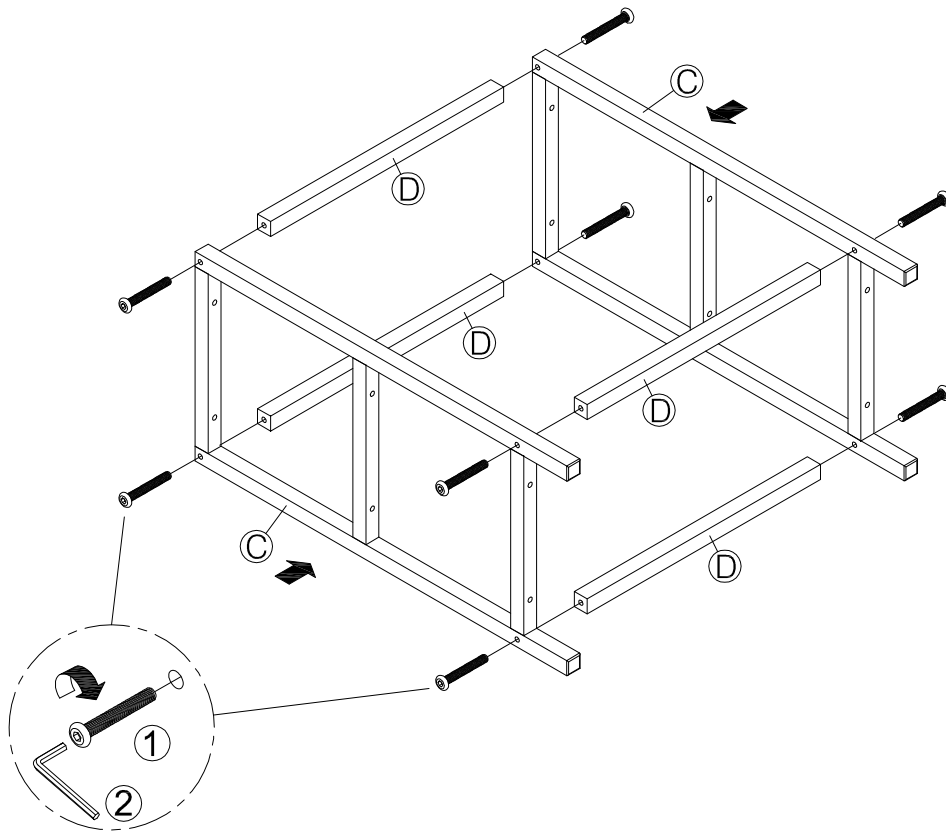
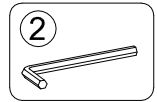
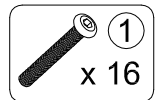

x 2

STEP 2 :

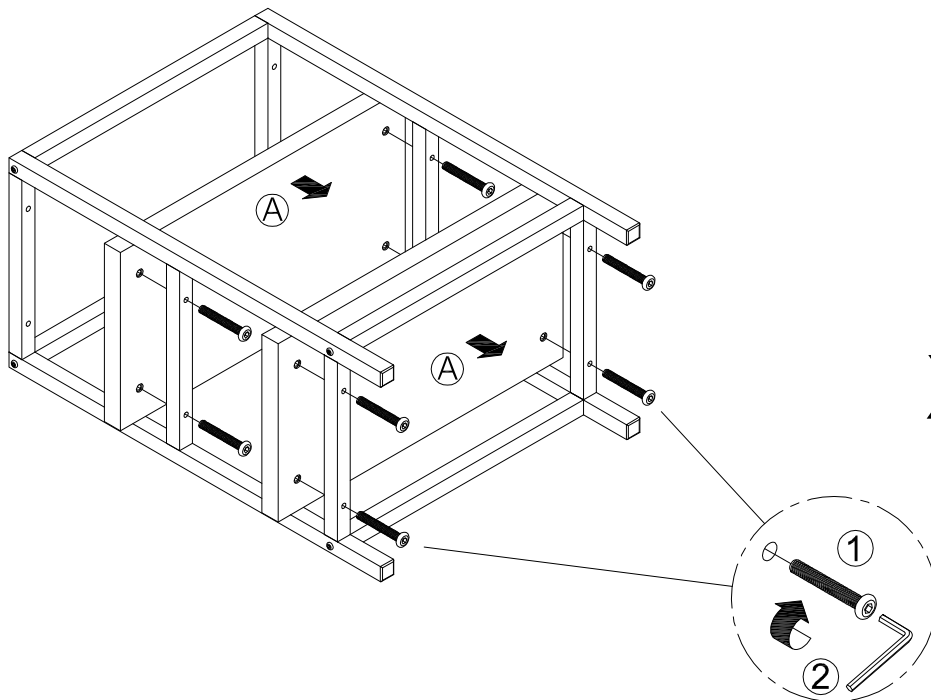
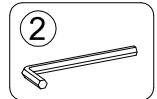
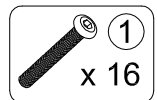

x 2

# ASSEMBLY INSTRUCTION

STEP 3 :

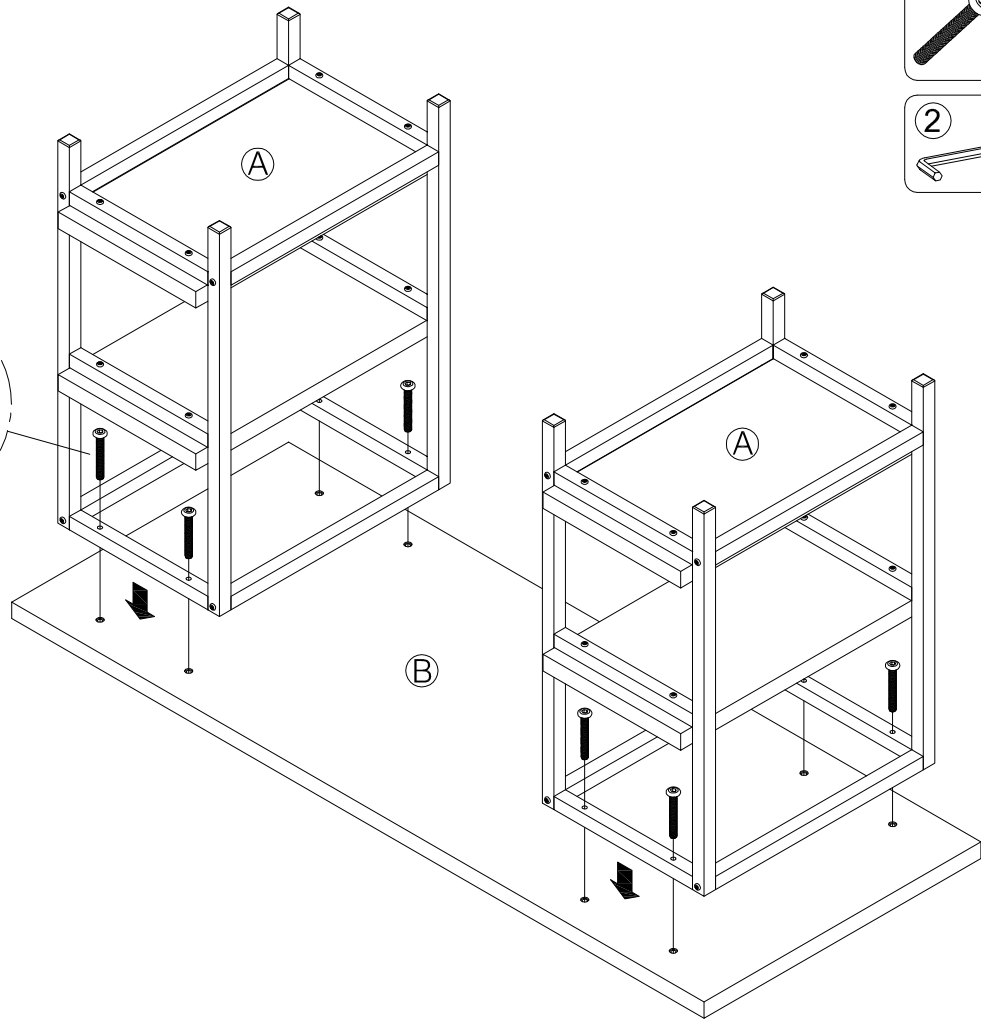
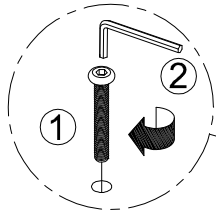
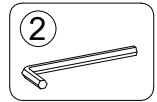
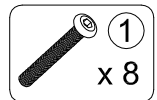

FINISH

