

FLEXSTEEL®

W1031 / W1032 - 90Q1 / 90Q2 / 90R3

Queen Panel Bed

IMPORTANT

Carefully remove all parts from the carton, and put them individually on a soft cloth to prevent damage to the parts.

We have taken great care in the design of this product and request that you carefully and accurately follow our assembly instructions to ensure proper set-up.

A Phillips Head Screwdriver is required for assembly (Not Provided)

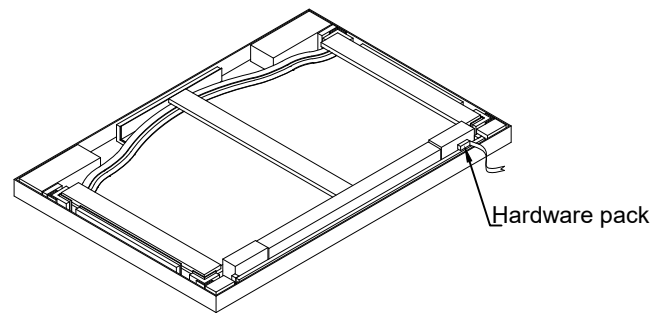
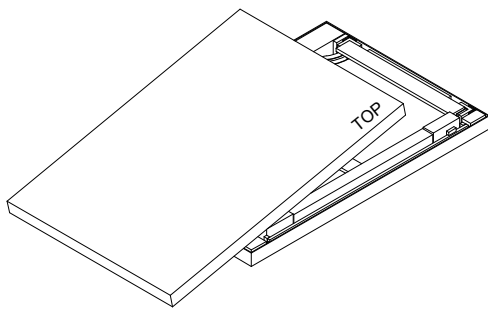
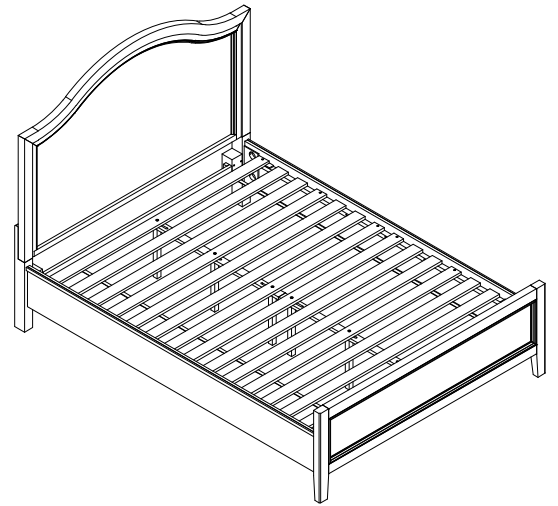

Part List

Assembly Instructions 1/4

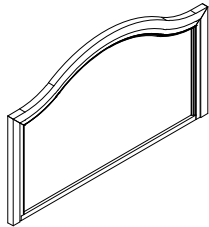

A. Headboard
1 piece

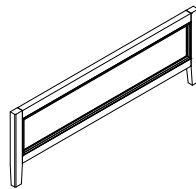

B. Footboard
1 piece

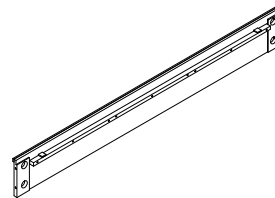

C. Side rail
2 pieces

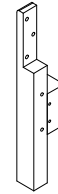

D. Headboard
Post Left
1 piece

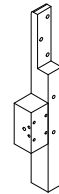

E. Headboard
Post Right
1 piece

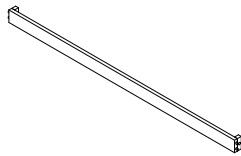

F. Headboard
Bottom Rail
1 piece

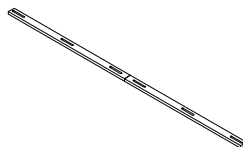

G. Center Rail
1 piece

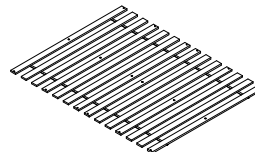

H. Roll Slats
1set



I. Slat Support
6 pieces

Hardware List

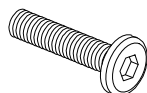

Bolt
Ø5/16" x 18 UNC x 1-1/2"
8 pieces



Spring Washer
Ø5/16" x 1.5mm
8 pieces



Flat Washer
Ø5/16" x Ø19 x 1.5mm
8 pieces

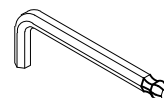

Hex Key
5/32"
1 piece

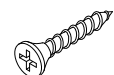

Screw
12 pieces

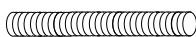

Thread Bolt
Ø5/16" x 18 UNC x 3-1/2"
8 pieces



Curved Washer
1" x 5/8" x 1/16"
8 pieces



Hexagonal Nut
Ø5/16" x 1/2"
8 pieces

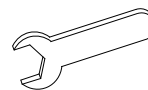

Spanner Wrench
1/2"
1 pieces

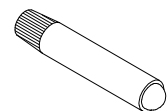

Touch-up Pen
1 piece

FLEXSTEEL®

Assembly Instructions 2/4

IMPORTANT NOTES

- Do not tighten up all the bolts until each part is properly assembled.
- Keep the Hex Key and Spanner Wrench in a safe place as you may need to tighten up the bolts in the future.
- Use a soft cloth between these parts and the floor.
- We recommend this product be assembled by at least two adults.

STEP 1

Fix Headboard Post Left (D) and Headboard Post Right (E) to Headboard Bottom Rail (F). Insert Bolts, Spring Washers, Flat Washers and fully tighten bolts with Hex Key. (See Figure 1)

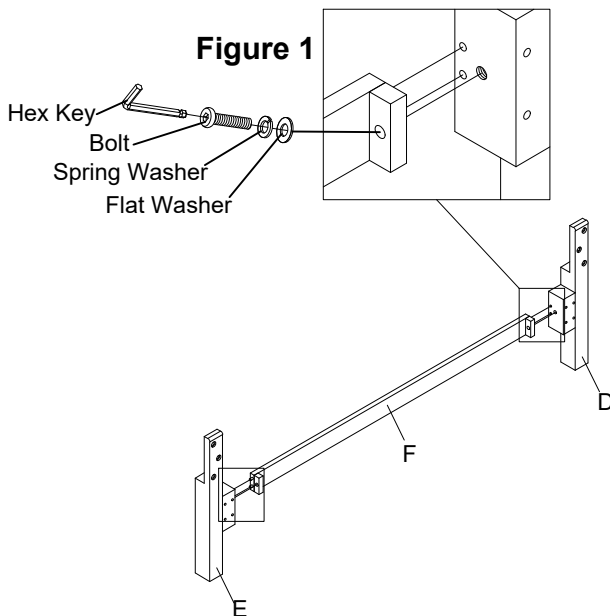

STEP 2

Fix Headboard Post Left (D) and Headboard Post Right (E) to Headboard (A). Insert Bolts, Spring Washers, Flat Washers and fully tighten bolts with Hex Key. (See Figure 2)

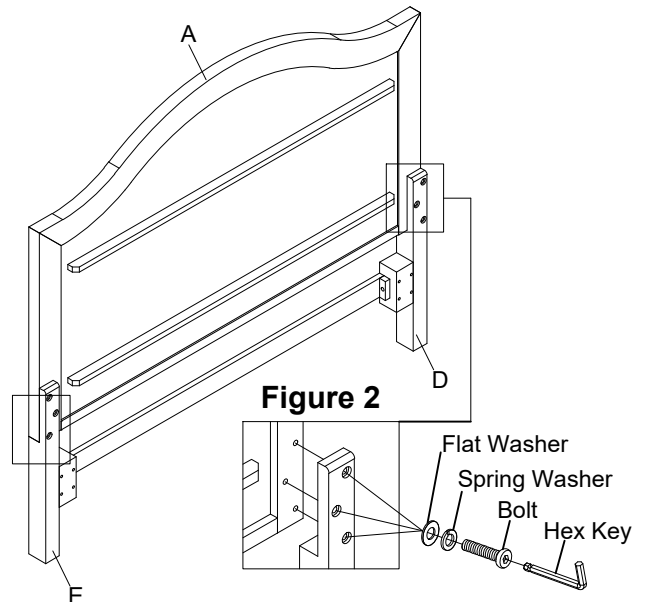

STEP 3

Connect the Side rails (C) to Headboard Post (D) and (E) and Footboard (B). Insert Thread Bolts, Curved Washers, Hexagonal Nuts and fully tighten bolts with Spanner Wrench. (See Figure 3)

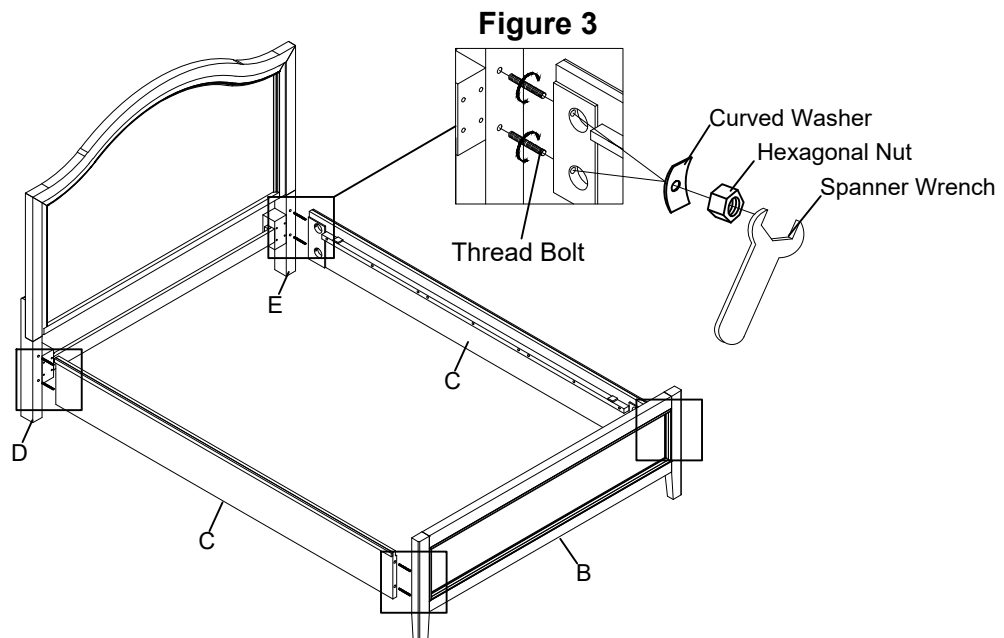

FLEXSTEEL®

Assembly Instructions 3/4

IMPORTANT NOTES

- Do not tighten up all the bolts until each part is properly assembled.
- Keep the Hex Key and Spanner Wrench in a safe place as you may need to tighten up the bolts in the future.
- Use a soft cloth between these parts and the floor.
- We recommend this product be assembled by at least two adults.

STEP 4

Connect the Slat Supports (I) and Center Rail (G) to Roll Slats (H) by passing the bolt on the Slat Supports (I) through the slots in the Center Rails (G), and rotating them by hand clockwise until tight. (See Figure 4)

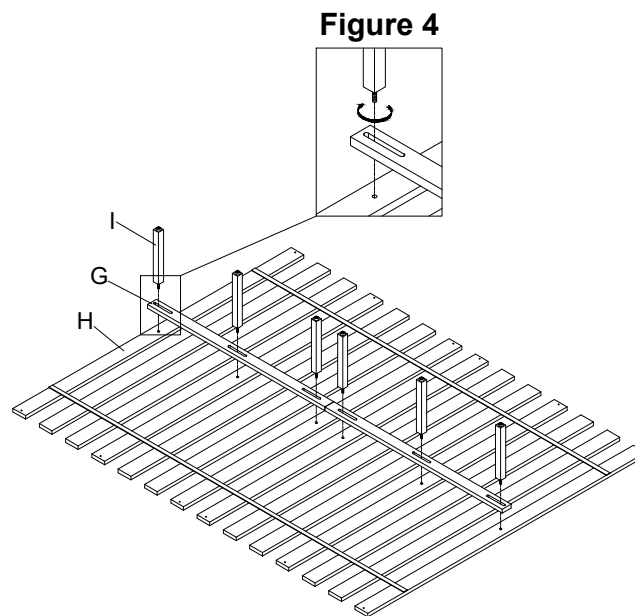

STEP 5

Fix Roll Slats (H) to Side rails (C). Insert Screws. (See Figure 5)

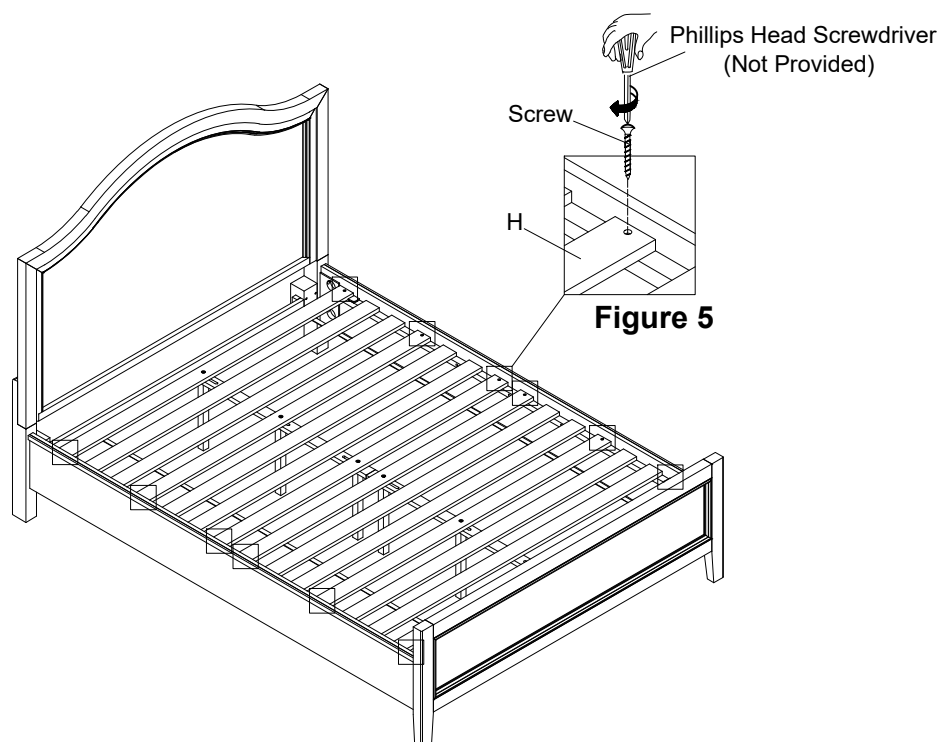

FLEXSTEEL®

Assembly Instructions 4/4

IMPORTANT NOTES

- Do not tighten up all the bolts until each part is properly assembled.
- Keep the Hex Key and Spanner Wrench in a safe place as you may need to tighten up the bolts in the future.
- Use a soft cloth between these parts and the floor.
- We recommend this product be assembled by at least two adults.

STEP 6

Adjust the levelers on the Slat Supports (I) to ensure they are all touching the floor. (See Figure 6)

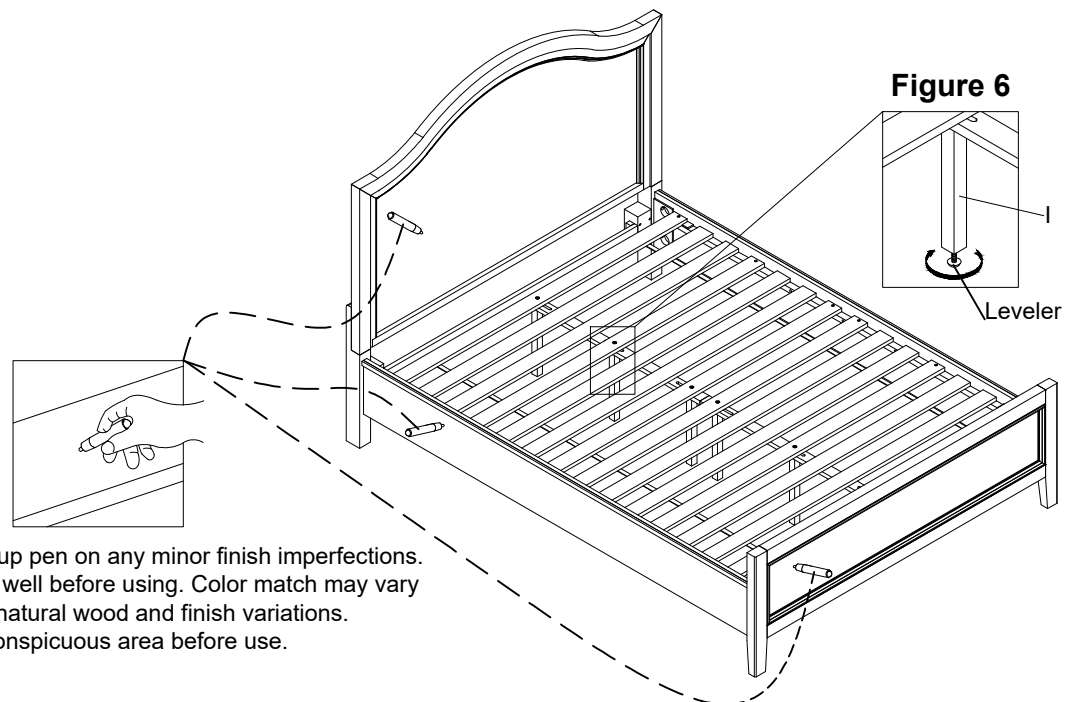

Use the touch-up pen on any minor finish imperfections. Shake the pen well before using. Color match may vary slightly due to natural wood and finish variations. Test on an inconspicuous area before use.

CARE INSTRUCTIONS

- To avoid scratches, do not place sharp or jagged objects directly on the bed.
- Do not place hot items directly on the bed.
- Avoid the use of harsh chemicals or abrasive cleaning materials.
- Wipe the bed clean with a soft, dry cloth after each use.
- Wipe up spills quickly with a soft, dry cloth.

Flexsteel Industries, Inc.

For Parts or Customer Service call

toll-free:

1-888-415-3979

Monday-Friday

8:00 a.m. -5:00 p.m.

(Central Time)

Email:

customersolutions@flexsteel.com

www.flexsteel.com

FLEXSTEEL®

W1031 / W1032-860

Dresser

IMPORTANT

Carefully remove all parts from the carton, and put them individually on a soft cloth to prevent damage to the parts.

We have taken great care in the design of this product and request that you carefully and accurately follow our assembly instructions to ensure proper set-up.

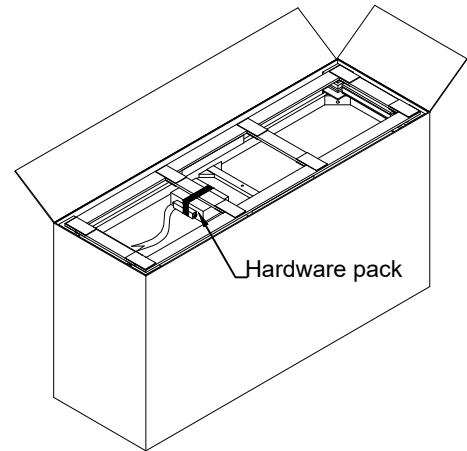
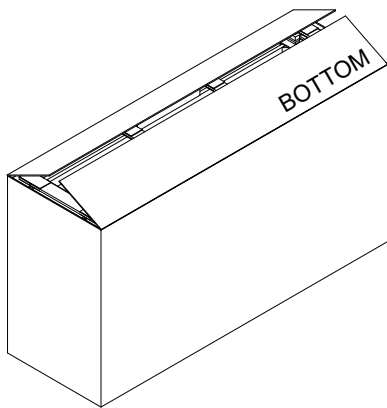
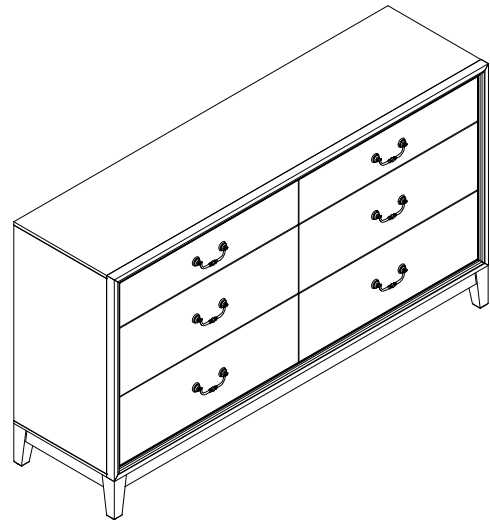

Part List

Assembly Instructions 1/3

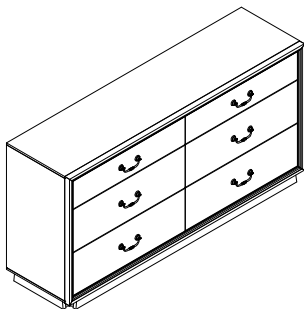

A. Box
1 piece



B. Leg
4 pieces



C. Support Leg
1 piece

Hardware List

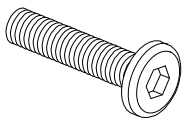

Bolt
Ø5/16" x 18 UNC x 2"
8 pieces



Spring Washer
Ø5/16" x 1.5mm
8 pieces



Flat Washer
Ø5/16" x Ø19 x 1.5mm
8 pieces

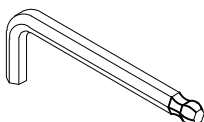

Hex Key
5/32"
1 piece

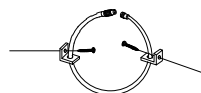

Anti-Tipping
1set

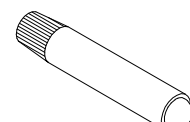

Touch-up Pen
1 piece

FLEXSTEEL®

Assembly Instructions 2/3

IMPORTANT NOTES

- Do not tighten up all the bolts until each part is properly assembled.
- Keep the Hex Key in a safe place as you may need to tighten up the bolts in the future.
- Use a soft cloth between these parts and the floor.
- We recommend this product be assembled by at least two adults.

STEP 1

Open carton box from the bottom, and take out the assembly parts where it is located - Leg (B), Support Leg (C) and Hardware pack. (See Figure 1)

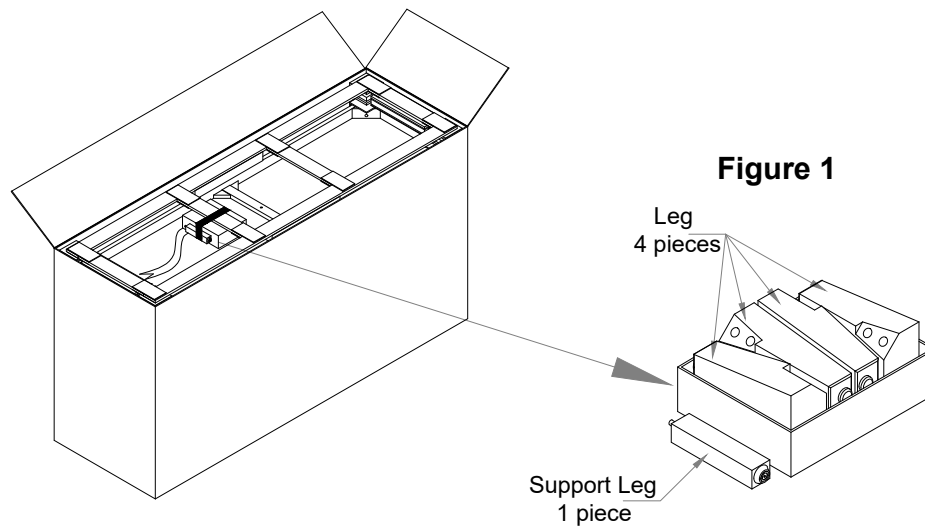

STEP 2

Fix Legs (B) to each corner of the Dresser (A). Insert Bolts, Spring Washers, Flat Washers and fully tighten bolts with Hex Key (See Figure 2). Connect the Support Leg (C) to Dresser (A) by rotating it clockwise by hand until tight. (See Figure 3)

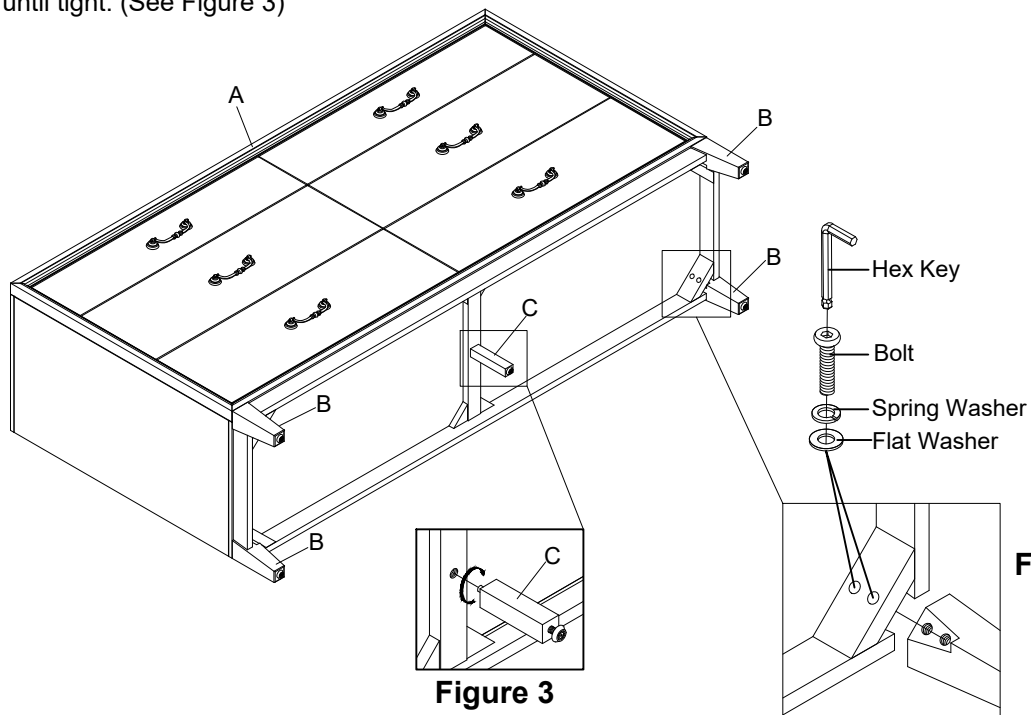

FLEXSTEEL®

Assembly Instructions 3/3

IMPORTANT NOTES

- Do not tighten up all the bolts until each part is properly assembled.
- Keep the Hex Key in a safe place as you may need to tighten up the bolts in the future.
- Use a soft cloth between these parts and the floor.
- We recommend this product be assembled by at least two adults.

STEP 3

Adjust the levelers on the legs until the furniture is leveled. (See Figure 4)

The drawers can be adjusted up or down as necessary using the adjustment knob under the drawers on the drawer glides. (See Figure 5)

Pull out the slide latch at the bottom of the drawer and lift the drawer up to remove it. (See Figure 6)

NOTE: There is a tip restraint kit provided on the back of this product. Take care to read the instructions thoroughly and install it immediately when placed in the home.

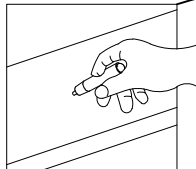
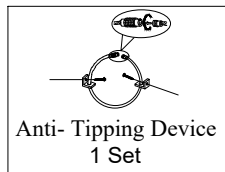

Use the touch-up pen on any minor finish imperfections. Shake the pen well before using. Color match may vary slightly due to natural wood and finish variations. Test on an inconspicuous area before use.

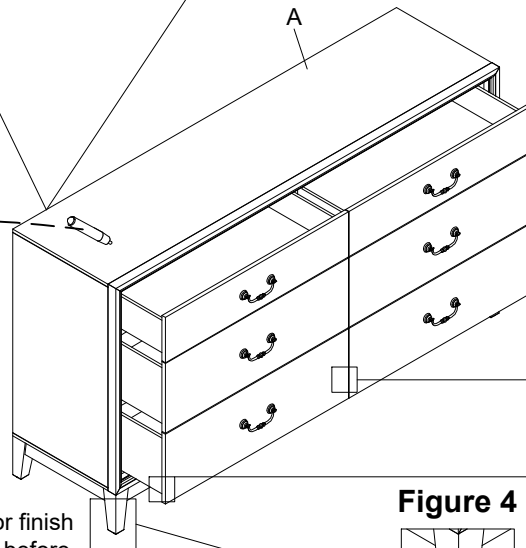
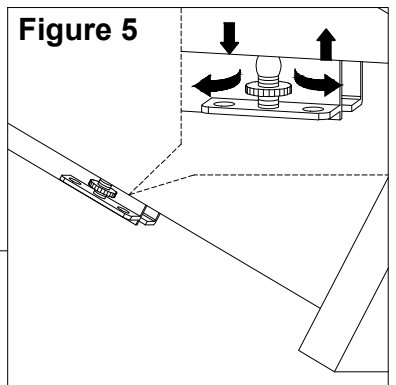
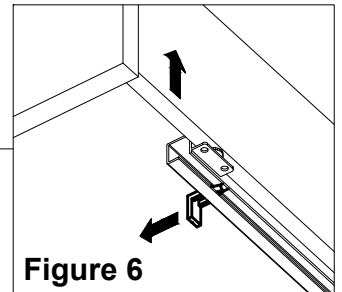

Figure 4

Adjustable leveler



CARE INSTRUCTIONS

- To avoid scratches, do not place sharp or jagged objects directly on the cabinet.
- Do not place hot items directly on the cabinet.
- Use placemats or trivets under hot items and coasters under beverages to prevent marks and stains.
- Avoid the use of harsh chemicals or abrasive cleaning materials.
- Wipe the cabinet clean with a soft, dry cloth after each use.
- Wipe up spills quickly with a soft, dry cloth.

Flexsteel Industries, Inc.

For Parts or Customer Service call

toll-free:

1-888-415-3979

Monday-Friday

8:00 a.m. -5:00 p.m.

(Central Time)

Email:

customersolutions@flexsteel.com

www.flexsteel.com

FLEXSTEEL®

W1031 / W1032 - 90K1 / 90K2 / 90R3

King Panel Bed

IMPORTANT

Carefully remove all parts from the carton, and put them individually on a soft cloth to prevent damage to the parts.

We have taken great care in the design of this product and request that you carefully and accurately follow our assembly instructions to ensure proper set-up.

A Phillips Head Screwdriver is required for assembly (Not Provided)

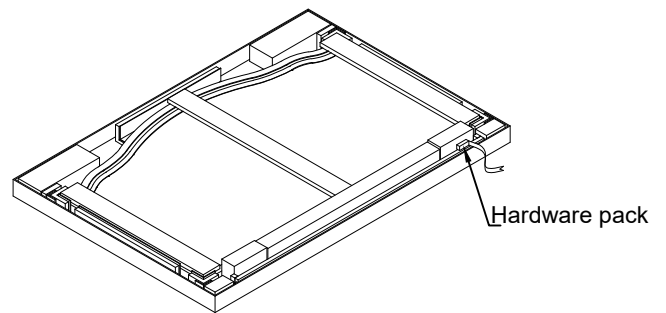
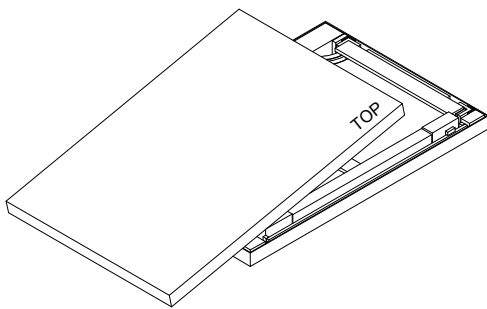
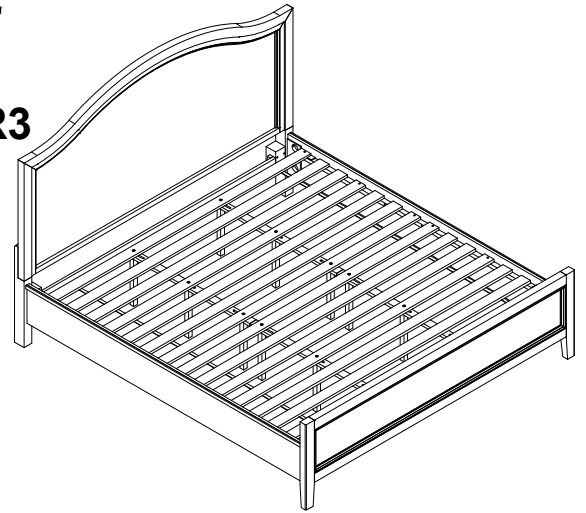

Part List

Assembly Instructions 1/4

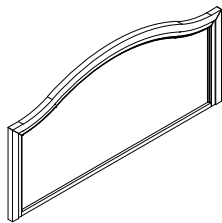

A. Headboard
1 piece

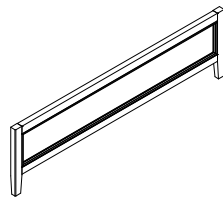

B. Footboard
1 piece

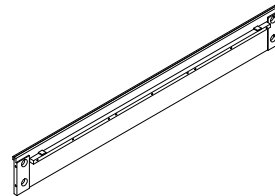

C. Side rail
2 pieces

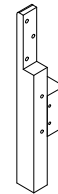

D. Headboard
Post Left
1 piece

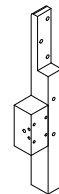

E. Headboard
Post Right
1 piece

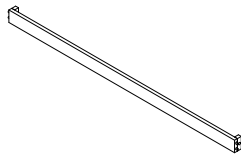

F. Headboard
Bottom Rail
1 piece

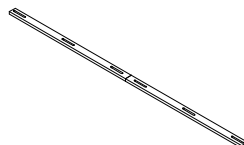

G. Center Rail
2 pieces

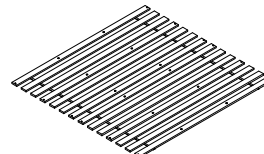

H. Roll Slats
1set



I. Slat Support
12 pieces

Hardware List

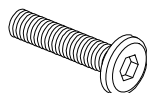

Bolt
Ø5/16" x 18 UNC x 1-1/2"
8 pieces



Spring Washer
Ø5/16" x 1.5mm
8 pieces



Flat Washer
Ø5/16" x Ø19 x 1.5mm
8 pieces

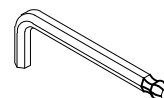

Hex Key
5/32"
1 piece

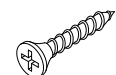

Screw
12 pieces

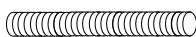

Thread Bolt
Ø5/16" x 18 UNC x 3-1/2"
8 pieces



Curved Washer
1" x 5/8" x 1/16"
8 pieces



Hexagonal Nut
Ø5/16" x 1/2"
8 pieces

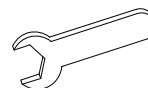

Spanner Wrench
1/2"
1 pieces

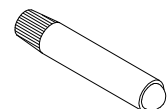

Touch-up Pen
1 piece

FLEXSTEEL®

Assembly Instructions 2/4

IMPORTANT NOTES

- Do not tighten up all the bolts until each part is properly assembled.
- Keep the Hex Key and Spanner Wrench in a safe place as you may need to tighten up the bolts in the future.
- Use a soft cloth between these parts and the floor.
- We recommend this product be assembled by at least two adults.

STEP 1

Fix Headboard Post Left (D) and Headboard Post Right (E) to Headboard Bottom Rail (F). Insert Bolts, Spring Washers, Flat Washers and fully tighten bolts with Hex Key. (See Figure 1)

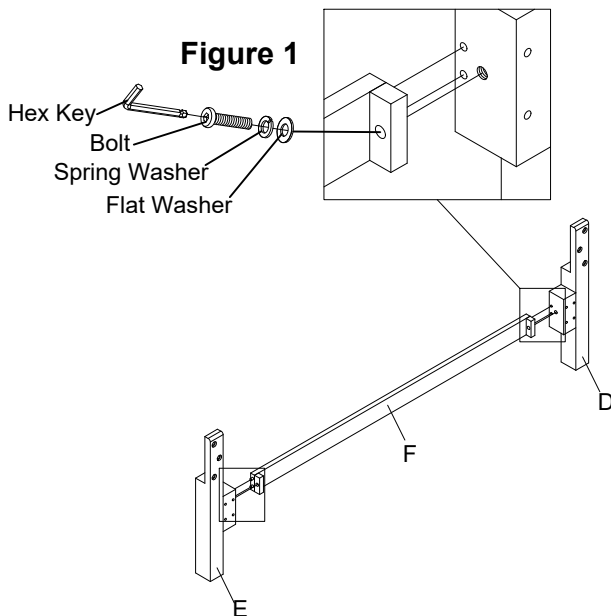

STEP 2

Fix Headboard Post Left (D) and Headboard Post Right (E) to Headboard (A). Insert Bolts, Spring Washers, Flat Washers and fully tighten bolts with Hex Key. (See Figure 2)

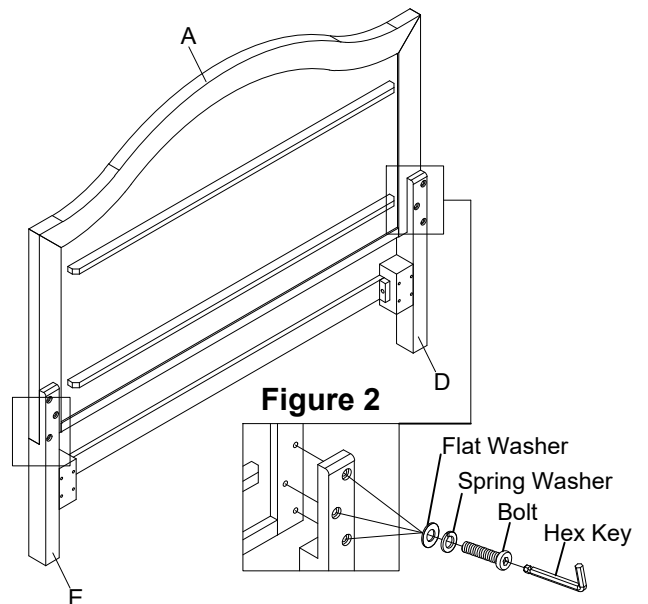

STEP 3

Connect the Side rails (C) to Headboard Post (D) and (E) and Footboard (B). Insert Thread Bolts, Curved Washers, Hexagonal Nuts and fully tighten bolts with Spanner Wrench. (See Figure 3)

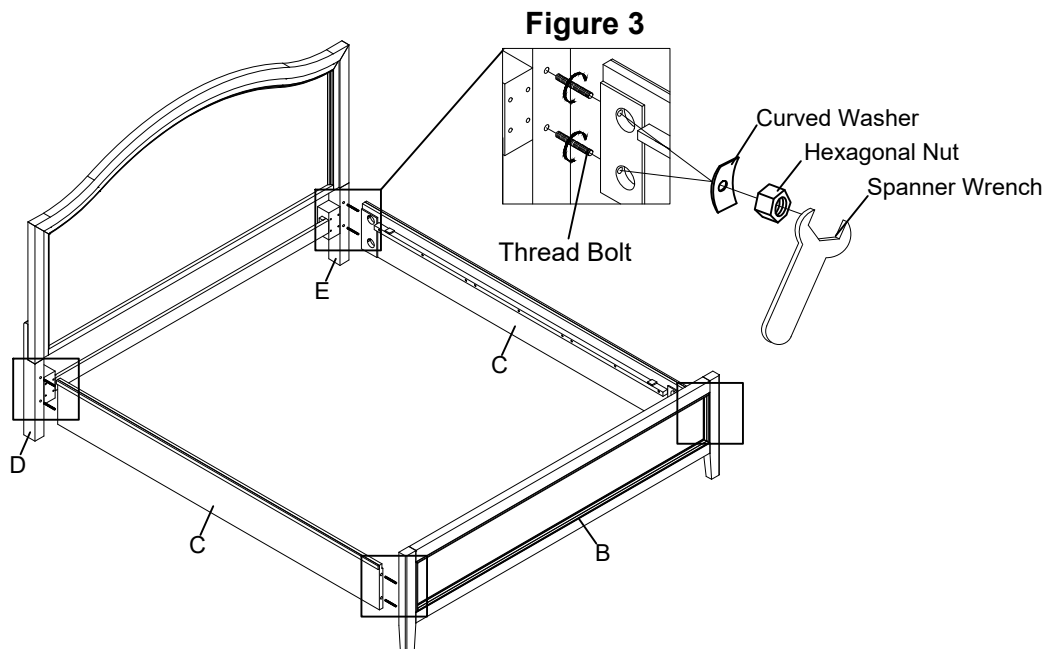

FLEXSTEEL®

Assembly Instructions 3/4

IMPORTANT NOTES

- Do not tighten up all the bolts until each part is properly assembled.
- Keep the Hex Key and Spanner Wrench in a safe place as you may need to tighten up the bolts in the future.
- Use a soft cloth between these parts and the floor.
- We recommend this product be assembled by at least two adults.

STEP 4

Connect the Slat Supports (I) and Center Rails (G) to Roll Slats (H) by passing the bolt on the Slat Supports (I) through the slots in the Center Rails (G), and rotating them by hand clockwise until tight. (See Figure 4)

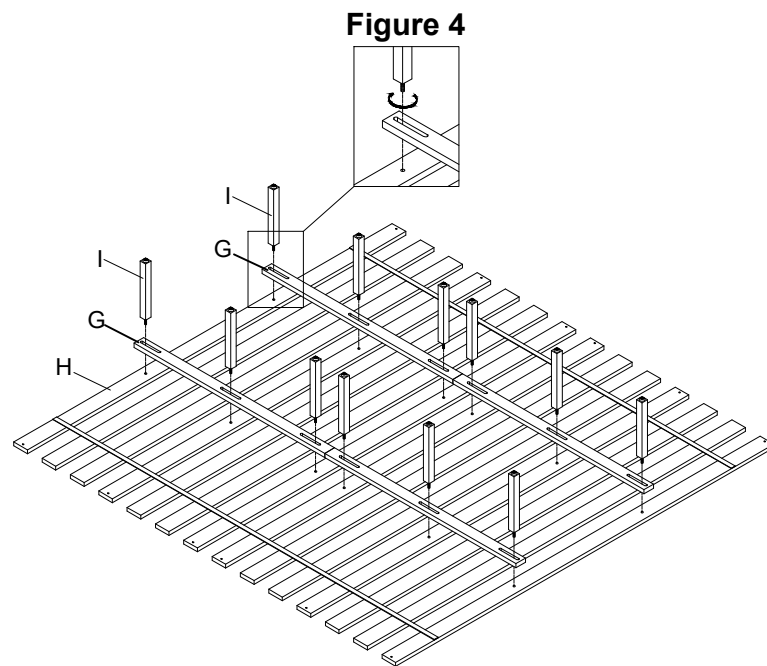

STEP 5

Fix Roll Slats (H) to Side rails (C). Insert Screws. (See Figure 5)

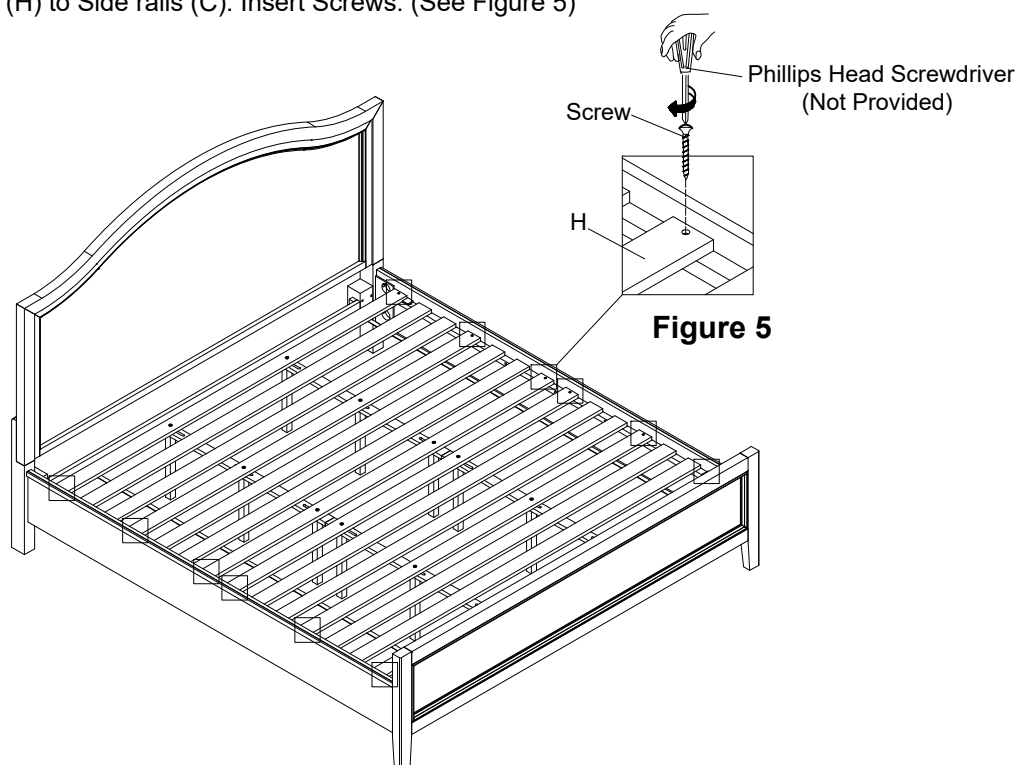

FLEXSTEEL®

Assembly Instructions 4/4

IMPORTANT NOTES

- Do not tighten up all the bolts until each part is properly assembled.
- Keep the Hex Key and Spanner Wrench in a safe place as you may need to tighten up the bolts in the future.
- Use a soft cloth between these parts and the floor.
- We recommend this product be assembled by at least two adults.

STEP 6

Adjust the levelers on the Slat Supports (I) to ensure they are all touching the floor. (See Figure 6)

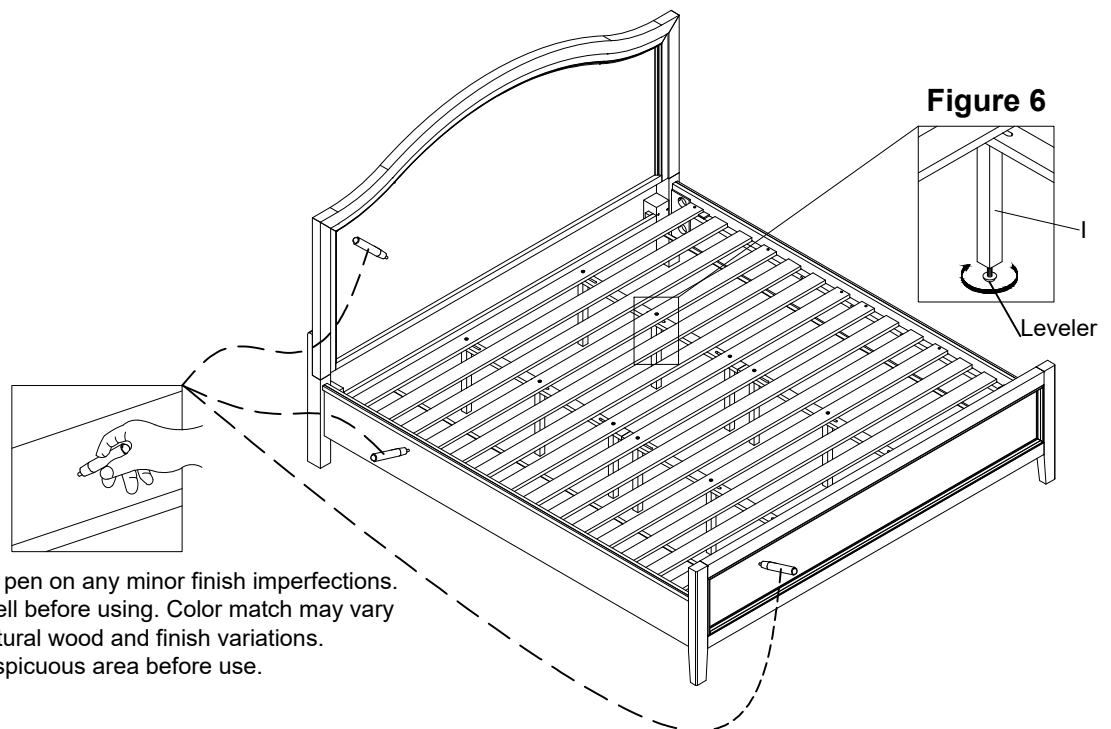

Use the touch-up pen on any minor finish imperfections. Shake the pen well before using. Color match may vary slightly due to natural wood and finish variations. Test on an inconspicuous area before use.

CARE INSTRUCTIONS

- To avoid scratches, do not place sharp or jagged objects directly on the bed.
- Do not place hot items directly on the bed.
- Avoid the use of harsh chemicals or abrasive cleaning materials.
- Wipe the bed clean with a soft, dry cloth after each use.
- Wipe up spills quickly with a soft, dry cloth.

Flexsteel Industries, Inc.

For Parts or Customer Service call

toll-free:

1-888-415-3979

Monday-Friday

8:00 a.m. -5:00 p.m.

(Central Time)

Email:

customersolutions@flexsteel.com

www.flexsteel.com

FLEXSTEEL®

W1031 / W1032-863

Nightstand

IMPORTANT

Carefully remove all parts from the carton, and put them individually on a soft cloth to prevent damage to the parts.

We have taken great care in the design of this product and request that you carefully and accurately follow our assembly instructions to ensure proper set-up.

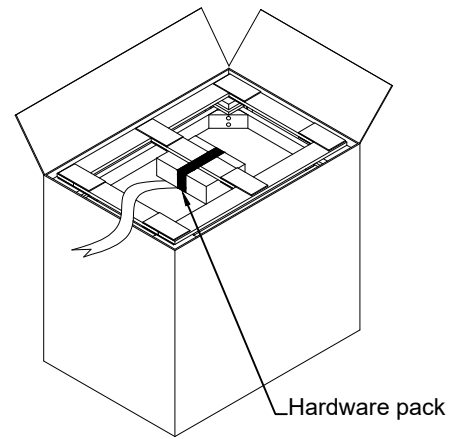
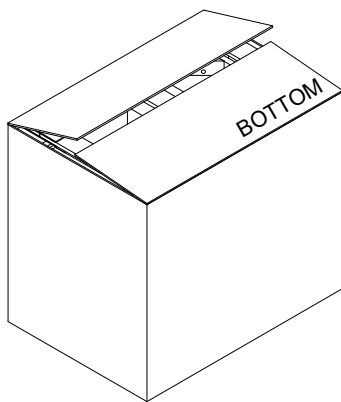
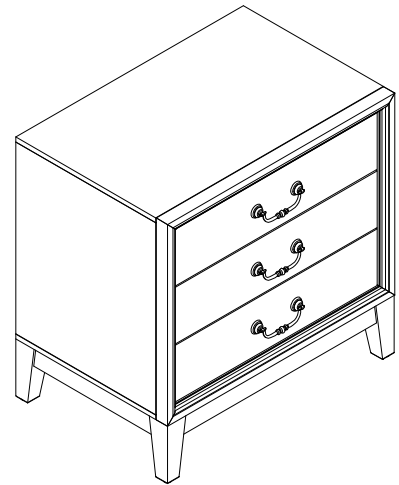

Part List

Assembly Instructions 1/3

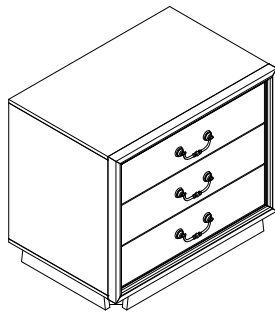

A. Box
1 piece



B. Leg
4 pieces

Hardware List

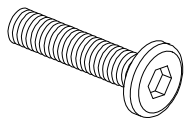

Bolt
Ø5/16" x 18 UNC x 2"
8 pieces



Spring Washer
Ø5/16" x 1.5mm
8 pieces



Flat Washer
Ø5/16" x Ø19 x 1.5mm
8 pieces

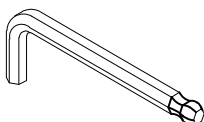

Hex Key
5/32"
1 piece

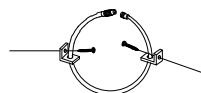

Anti-Tipping
1set

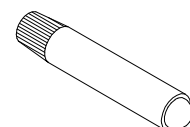

Touch-up Pen
1 piece

FLEXSTEEL®

Assembly Instructions 2/3

IMPORTANT NOTES

- Do not tighten up all the bolts until each part is properly assembled.
- Keep the Hex Key in a safe place as you may need to tighten up the bolts in the future.
- Use a soft cloth between these parts and the floor.
- We recommend this product be assembled by at least two adults.

STEP 1

Open carton box from the bottom, and take out the assembly parts where it is located - Leg (B) and Hardware pack. (See Figure 1)

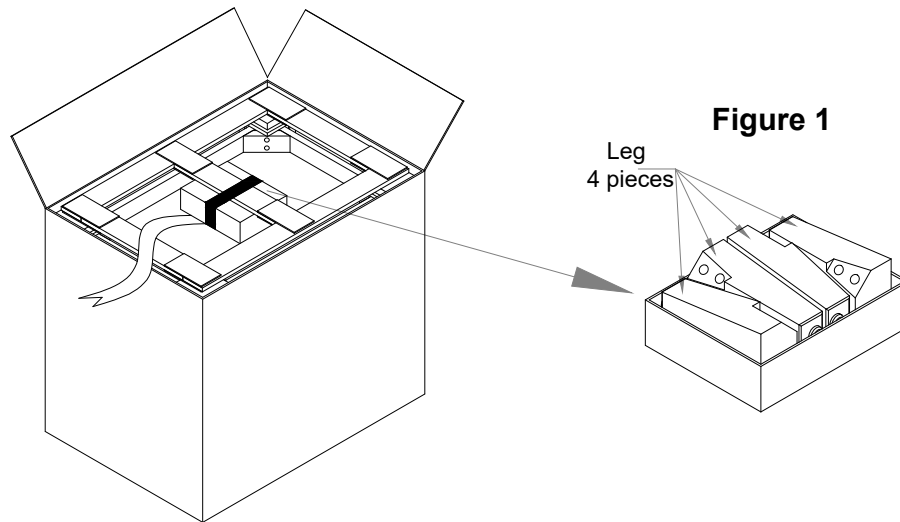

STEP 2

Fix Legs (B) to each corner of the Box (A). Insert Bolts, Spring Washers, Flat Washers and fully tighten bolts with Hex Key. (See Figure 2)

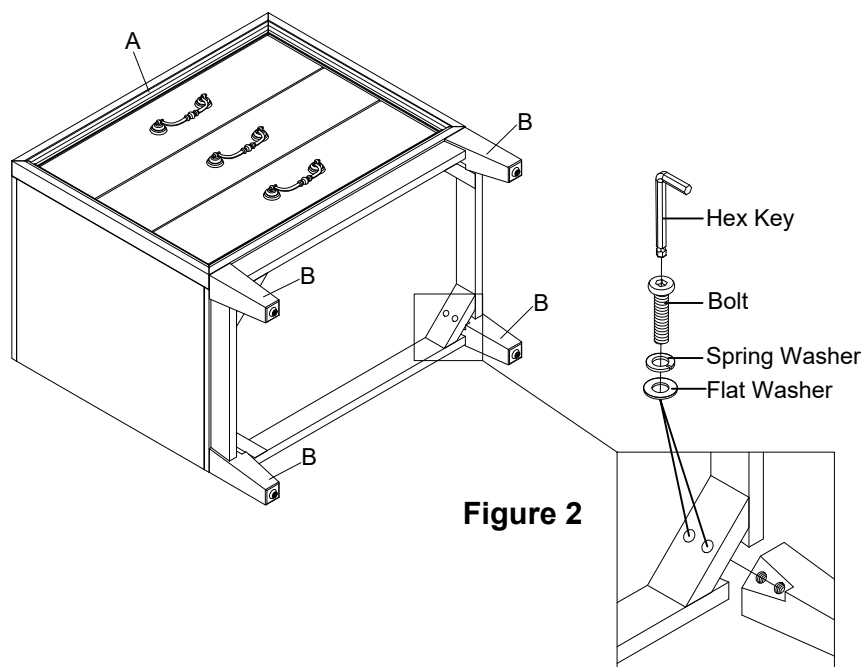

FLEXSTEEL®

Assembly Instructions 3/3

IMPORTANT NOTES

- Do not tighten up all the bolts until each part is properly assembled.
- Keep the Hex Key in a safe place as you may need to tighten up the bolts in the future.
- Use a soft cloth between these parts and the floor.
- We recommend this product be assembled by at least two adults.

STEP 3

Adjust the levelers on the legs until the furniture is leveled. (See Figure 3)

The drawers can be adjusted up or down as necessary using the adjustment knob under the drawers on the drawer glides. (See Figure 4)

Pull out the slide latch at the bottom of the drawer and lift the drawer up to remove it. (See Figure 5)

NOTE: There is a tip restraint kit provided on the back of this product. Take care to read the instructions thoroughly and install it immediately when placed in the home.

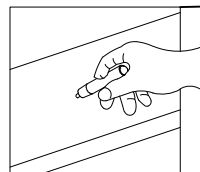
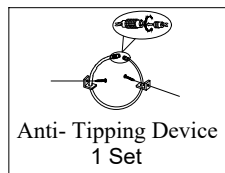

Use the touch-up pen on any minor finish imperfections. Shake the pen well before using. Color match may vary slightly due to natural wood and finish variations. Test on an inconspicuous area before use.

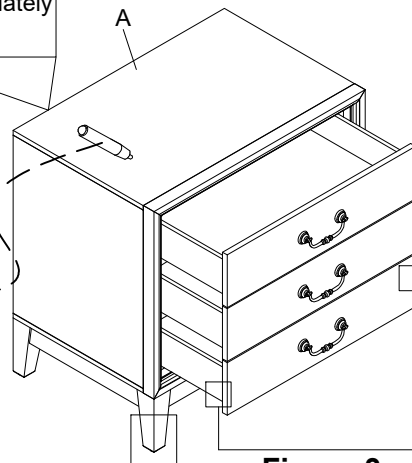

Figure 3

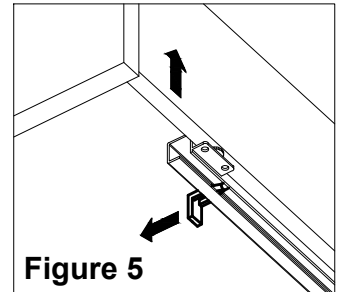

Figure 5

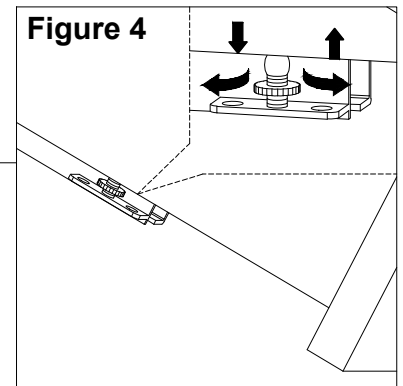

Figure 4

CARE INSTRUCTIONS

- To avoid scratches, do not place sharp or jagged objects directly on the cabinet.
- Do not place hot items directly on the cabinet.
- Use placemats or trivets under hot items and coasters under beverages to prevent marks and stains.
- Avoid the use of harsh chemicals or abrasive cleaning materials.
- Wipe the cabinet clean with a soft, dry cloth after each use.
- Wipe up spills quickly with a soft, dry cloth.

Flexsteel Industries, Inc.

For Parts or Customer Service call

toll-free:

1-888-415-3979

Monday-Friday

8:00 a.m. -5:00 p.m.

(Central Time)

Email:

customersolutions@flexsteel.com

www.flexsteel.com

FLEXSTEEL®

W1031 / W1032-864

Open Nightstand

IMPORTANT

Carefully remove all parts from the carton, and put them individually on a soft cloth to prevent damage to the parts.

We have taken great care in the design of this product and request that you carefully and accurately follow our assembly instructions to ensure proper set-up.

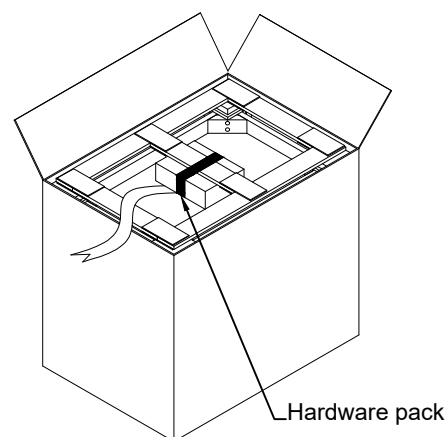
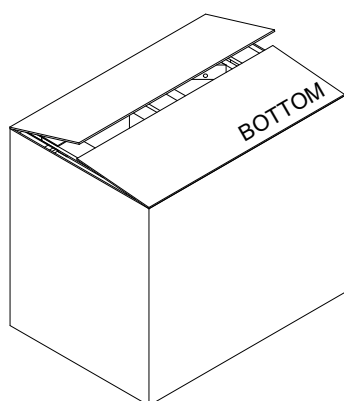
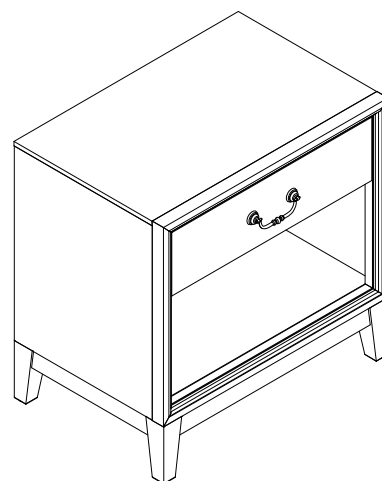

Part List

Assembly Instructions 1/3

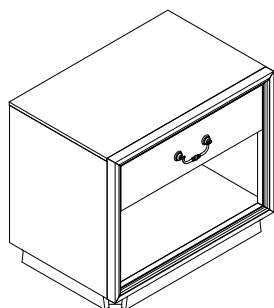

A. Box
1 piece



B. Leg
4 pieces

Hardware List

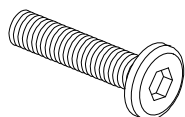

Bolt
Ø5/16" x 18 UNC x 2"
8 pieces



Spring Washer
Ø5/16" x 1.5mm
8 pieces



Flat Washer
Ø5/16" x Ø19 x 1.5mm
8 pieces

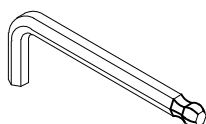

Hex Key
5/32"
1 piece

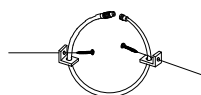

Anti-Tipping
1set

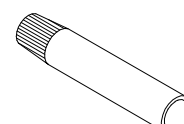

Touch-up Pen
1 piece

FLEXSTEEL®

Assembly Instructions 2/3

IMPORTANT NOTES

- Do not tighten up all the bolts until each part is properly assembled.
- Keep the Hex Key in a safe place as you may need to tighten up the bolts in the future.
- Use a soft cloth between these parts and the floor.
- We recommend this product be assembled by at least two adults.

STEP 1

Open carton box from the bottom, and take out the assembly parts where it is located - Leg (B) and Hardware pack. (See Figure 1)

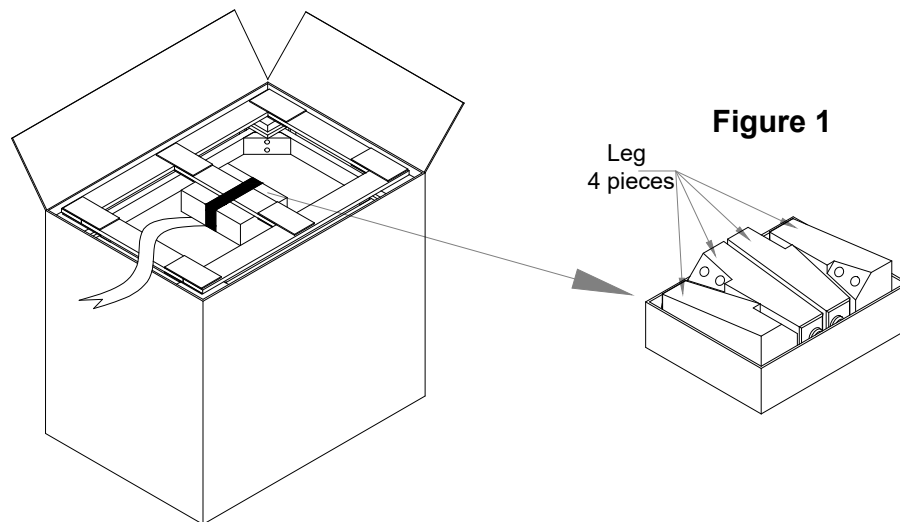

STEP 2

Fix Legs (B) to each corner of the Box (A). Insert Bolts, Spring Washers, Flat Washers and fully tighten bolts with Hex Key. (See Figure 2)

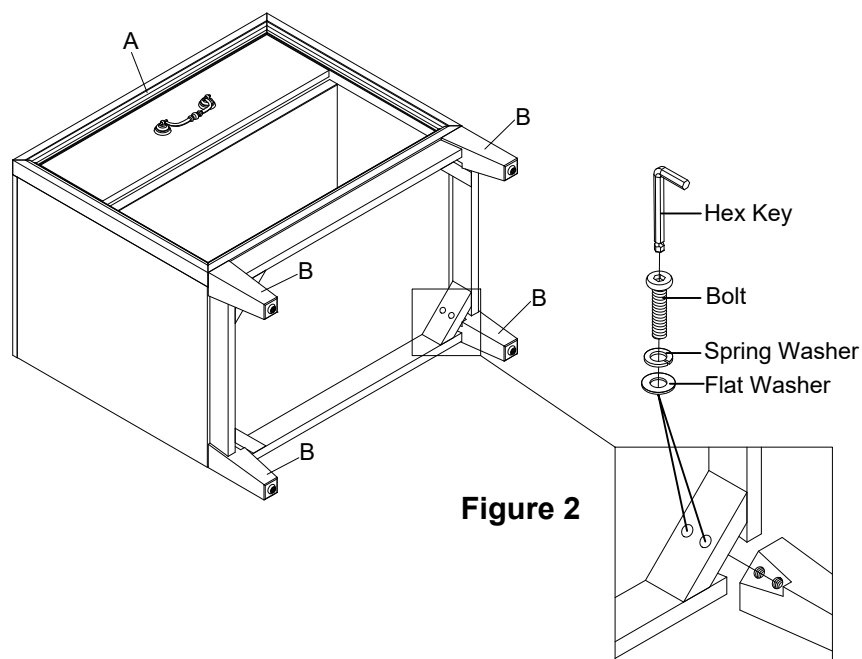

FLEXSTEEL®

Assembly Instructions 3/3

IMPORTANT NOTES

- Do not tighten up all the bolts until each part is properly assembled.
- Keep the Hex Key in a safe place as you may need to tighten up the bolts in the future.
- Use a soft cloth between these parts and the floor.
- We recommend this product be assembled by at least two adults.

STEP 3

Adjust the levelers on the legs until the furniture is leveled. (See Figure 3)

The drawer can be adjusted up or down as necessary using the adjustment knob under the drawers on the drawer glides. (See Figure 4)

Pull out the slide latch at the bottom of the drawer and lift the drawer up to remove it. (See Figure 5)

NOTE: There is a tip restraint kit provided on the back of this product. Take care to read the instructions thoroughly and install it immediately when placed in the home.

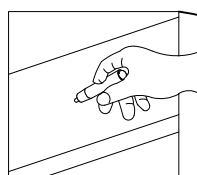
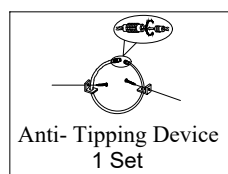

Use the touch-up pen on any minor finish imperfections. Shake the pen well before using. Color match may vary slightly due to natural wood and finish variations. Test on an inconspicuous area before use.

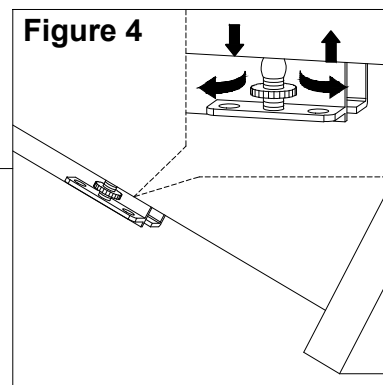
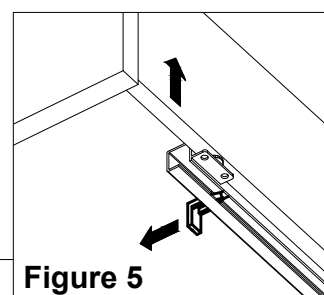
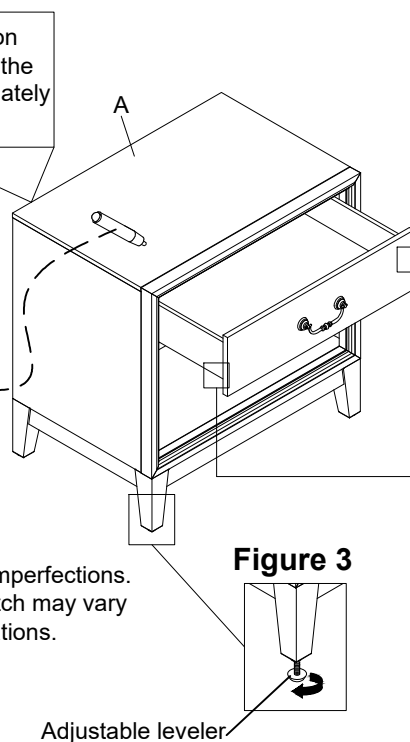

CARE INSTRUCTIONS

- To avoid scratches, do not place sharp or jagged objects directly on the cabinet.
- Do not place hot items directly on the cabinet.
- Use placemats or trivets under hot items and coasters under beverages to prevent marks and stains.
- Avoid the use of harsh chemicals or abrasive cleaning materials.
- Wipe the cabinet clean with a soft, dry cloth after each use.
- Wipe up spills quickly with a soft, dry cloth.

Flexsteel Industries, Inc.

For Parts or Customer Service call

toll-free:

1-888-415-3979

Monday-Friday

8:00 a.m. -5:00 p.m.

(Central Time)

Email:

customersolutions@flexsteel.com

www.flexsteel.com

FLEXSTEEL®

W1031 / W1032-872

Chest

IMPORTANT

Carefully remove all parts from the carton, and put them individually on a soft cloth to prevent damage to the parts.

We have taken great care in the design of this product and request that you carefully and accurately follow our assembly instructions to ensure proper set-up.

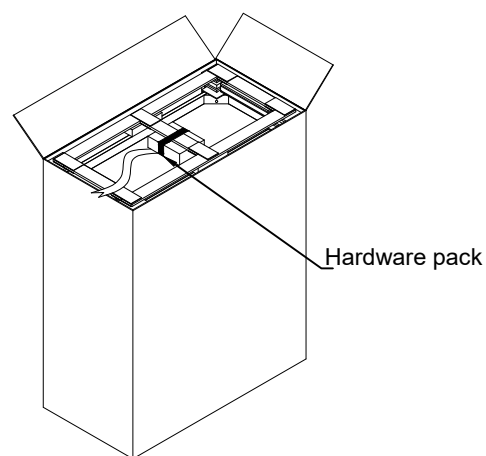
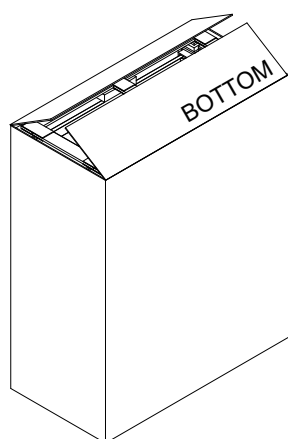
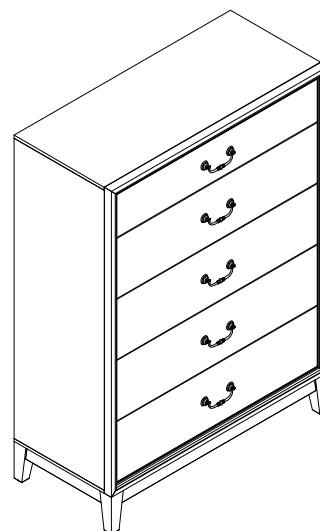

Part List

Assembly Instructions 1/3

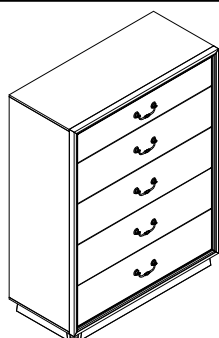

A. Box
1 piece



B. Leg
4 pieces

Hardware List

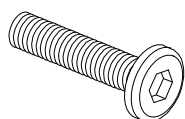

Bolt
Ø5/16" x 18 UNC x 2"
8 pieces



Spring Washer
Ø5/16" x 1.5mm
8 pieces



Flat Washer
Ø5/16" x Ø19 x 1.5mm
8 pieces

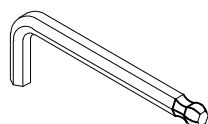

Hex Key
5/32"
1 piece

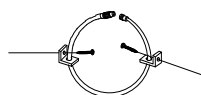

Anti-Tipping
1set

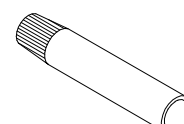

Touch-up Pen
1 piece

FLEXSTEEL®

Assembly Instructions 2/3

IMPORTANT NOTES

- Do not tighten up all the bolts until each part is properly assembled.
- Keep the Hex Key in a safe place as you may need to tighten up the bolts in the future.
- Use a soft cloth between these parts and the floor.
- We recommend this product be assembled by at least two adults.

STEP 1

Open carton box from the bottom, and take out the assembly parts where it is located - Leg (B) and Hardware pack. (See Figure 1)

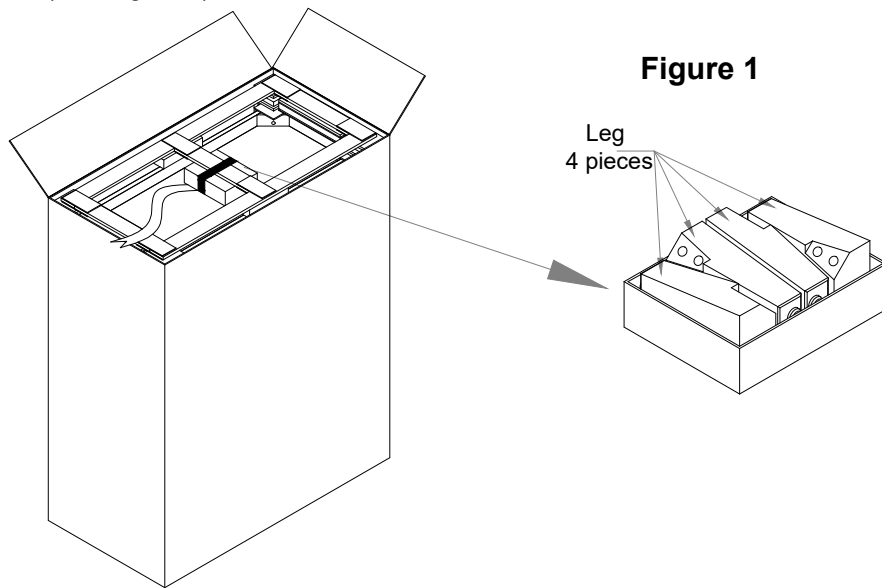

STEP 2

Fix Legs (B) to each corner of the Box (A). Insert Bolts, Spring Washers, Flat Washers and fully tighten bolts with Hex Key. (See Figure 2)

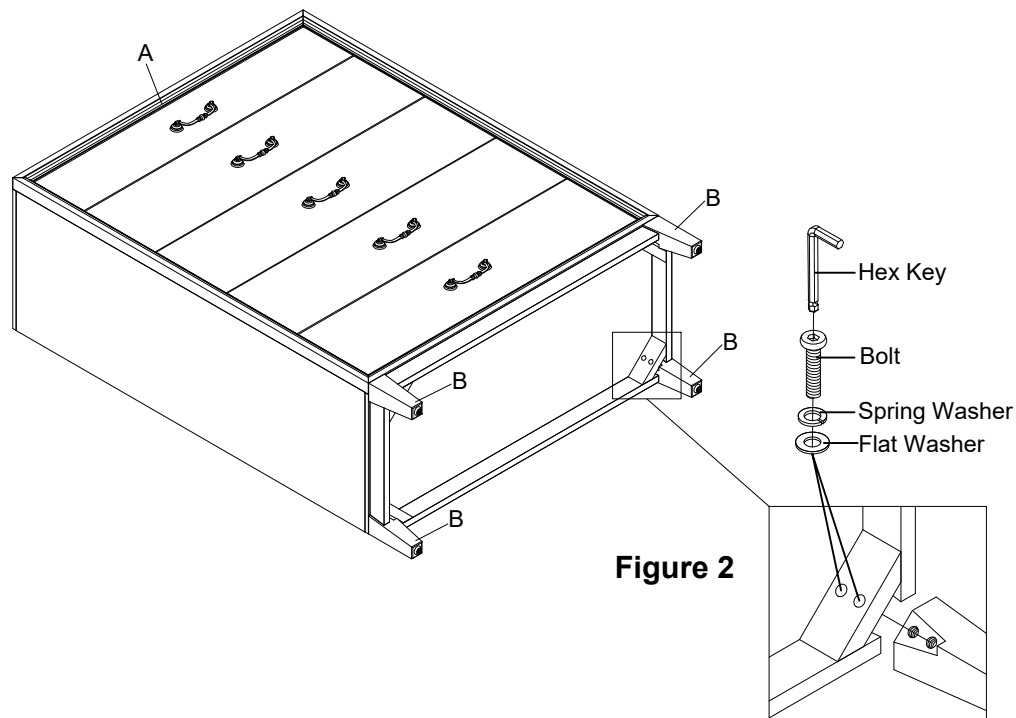

FLEXSTEEL®

Assembly Instructions 3/3

IMPORTANT NOTES

- Do not tighten up all the bolts until each part is properly assembled.
- Keep the Hex Key in a safe place as you may need to tighten up the bolts in the future.
- Use a soft cloth between these parts and the floor.
- We recommend this product be assembled by at least two adults.

STEP 3

Adjust the levelers on the legs until the furniture is leveled. (See Figure 3)

The drawers can be adjusted up or down as necessary using the adjustment knob under the drawers on the drawer glides. (See Figure 4)

Pull out the slide latch at the bottom of the drawer and lift the drawer up to remove it. (See Figure 5)

NOTE: There is a tip restraint kit provided on the back of this product. Take care to read the instructions thoroughly and install it immediately when placed in the home.

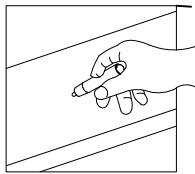
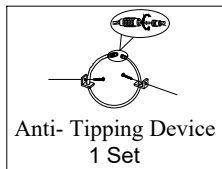

Use the touch-up pen on any minor finish imperfections. Shake the pen well before using. Color match may vary slightly due to natural wood and finish variations. Test on an inconspicuous area before use.

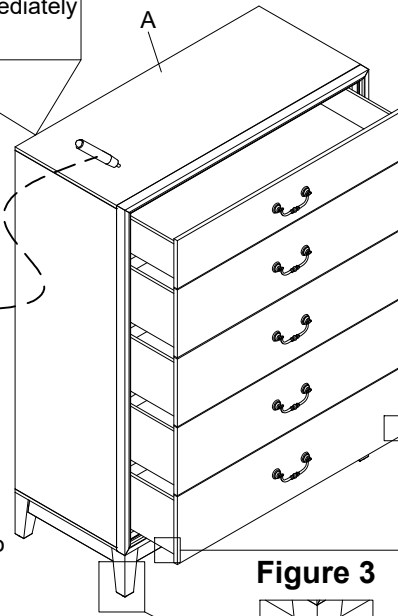

Figure 3

Adjustable leveler

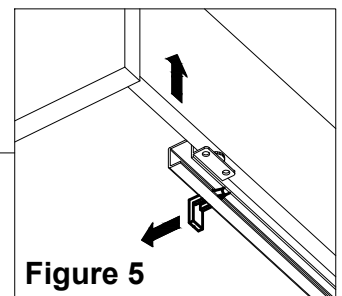
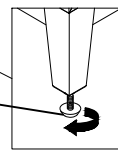

Figure 5

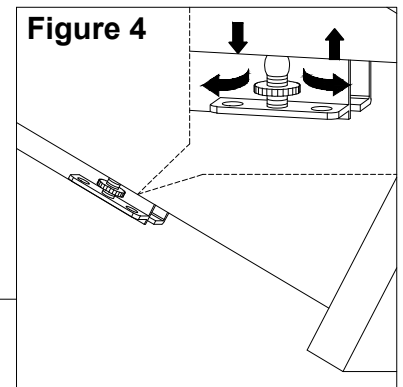

Figure 4

CARE INSTRUCTIONS

- To avoid scratches, do not place sharp or jagged objects directly on the cabinet.
- Do not place hot items directly on the cabinet.
- Use placemats or trivets under hot items and coasters under beverages to prevent marks and stains.
- Avoid the use of harsh chemicals or abrasive cleaning materials.
- Wipe the cabinet clean with a soft, dry cloth after each use.
- Wipe up spills quickly with a soft, dry cloth.

Flexsteel Industries, Inc.

For Parts or Customer Service call

toll-free:

1-888-415-3979

Monday-Friday

8:00 a.m. -5:00 p.m.

(Central Time)

Email:

customersolutions@flexsteel.com

www.flexsteel.com