

## Parts and Damage Replacement Procedure

1. Please inspect your purchase immediately.
2. This procedure covers product purchased from an authorized Reseller and was received in its originally sealed carton.
3. If you find a part missing or damaged, you have a 30-day window in which to order a replacement part from the date on your purchase receipt.
4. You have 3 ways to do this. You will need a copy of your purchase receipt.
  - a. By Fax: Fax the parts order form below and along with your receipt to
  - b. By Email: Email the order form and along with your receipt to: \_\_\_\_\_
  - c. By Mail: Fill out the parts order form below and along with a copy of your receipt send it to parts department
5. Once this order is sent in, you will be notified if the part(s) you are requesting can or cannot be shipped within 7-10 business days.

**A COPY OF YOUR PURCHASE RECEIPT OR INVOICE MUST BE ATTACHED TO THIS ORDER FORM.  
NO ORDERS WILL BE PROCESSED WITHOUT PROOF OF PURCHASE.**

NAME: \_\_\_\_\_

ADDRESS: \_\_\_\_\_ (No Post Office Boxes)

CITY: \_\_\_\_\_ STATE: \_\_\_\_\_ ZIP: \_\_\_\_\_

PHONE: \_\_\_\_\_ FAX: \_\_\_\_\_

EMAIL: \_\_\_\_\_

**REASON FOR REPLACEMENT/PLEASE CHECK APPROPRIATE BOX.**

- Damaged /scratched, cracked, broken, crushed, etc.
- Mechanical malfunction/ drawer glides, swivel mechanisms, lid stays, etc.
- Missing pieces
- Unfinished surface
- Wrong color
- Other

IF MORE THAN ONE MODEL NUMBER IS LISTED ABOVE, PLEASE SPECIFY THE EXACT MODEL NUMBER OF YOUR ITEM IN THE SPACE PROVIDED BELOW.

Model Number	Part Letter Code	Quantity

# ASSEMBLY INSTRUCTION

DESCRIPTION : PIER - LEFT AND RIGHT, WHITE LED LIGHTS

Thank you for purchasing this quality product. Be sure to check all packing material carefully for small Hardware which may have come loose inside the carton during shipment. Identify and count all Hardware and compare with the Hardware List below.

Component List		
Wall Pier (2 Set)		
No	Descriptions	Qty
A	Wall Panel	2
B	Shelf Panel	2

Component List		
Night Stand		
No	Descriptions	Qty
C	Night Stand	2

Component List		
Bed		
No	Descriptions	Qty
D	King / Queen Bed	1

Hardware List In Wall Pier		
No	Descriptions	Qty
1	Wood Dowel Ø8 x 30mm	4
2	PH Screw M4 x 16mm	16
3	JCBC M6 x 30mm	8
4	Spring Washer Ø1/4"	8
5	Flat Washer Ø1/4" x 20mm	8
6	Metal Plate	4
7	L Key M4	1
8	DC Adapter	2

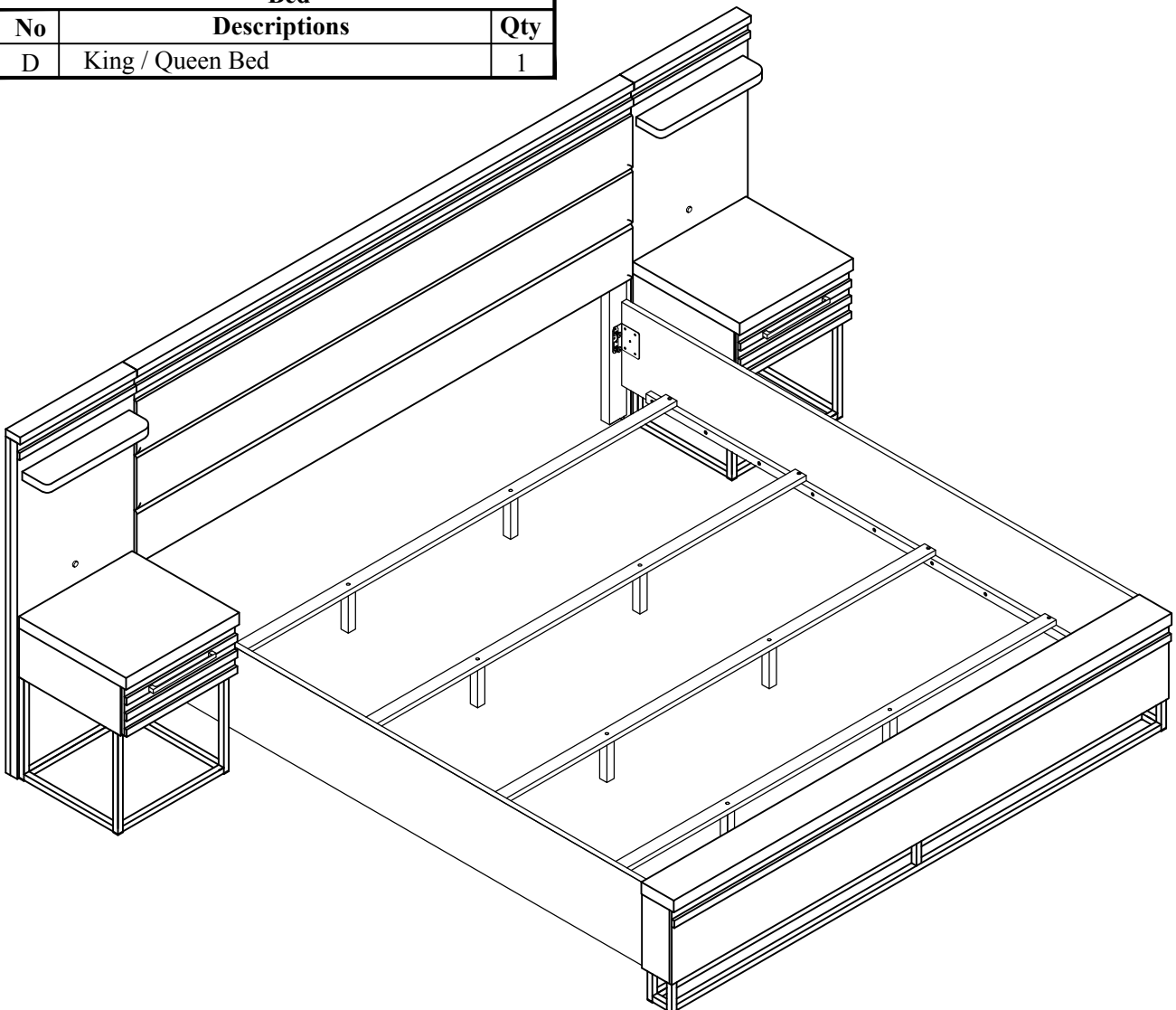

# ASSEMBLY INSTRUCTION

DESCRIPTION : PIER - LEFT AND RIGHT, WHITE LED LIGHTS

Thank you for purchasing this quality product. Be sure to check all packing material carefully for small Hardware which may have come loose inside the carton during shipment. Identify and count all Hardware and compare with the Hardware List below.

STEP 1 : Insert Wood Dowel (1) to the 2nd and 4th pre-drilled hole at Wall Panel (A). Attach Shelf Panel (B) to Wall Panel (A) guided by the attached Wood Dowel at Wall Panel (A).

STEP 2 : Then, tighten the Shelf Panel (B) by screw the back of Wall Panel (A) using JCBC M6 x 30mm (3), Spring washer (4), Flat washer (5) and Allen key M4 (7).

STEP 3 : Lastly, connect the connector from Shelf Panel with connector from the connector box attached at Back of Wall Panel as shown below.

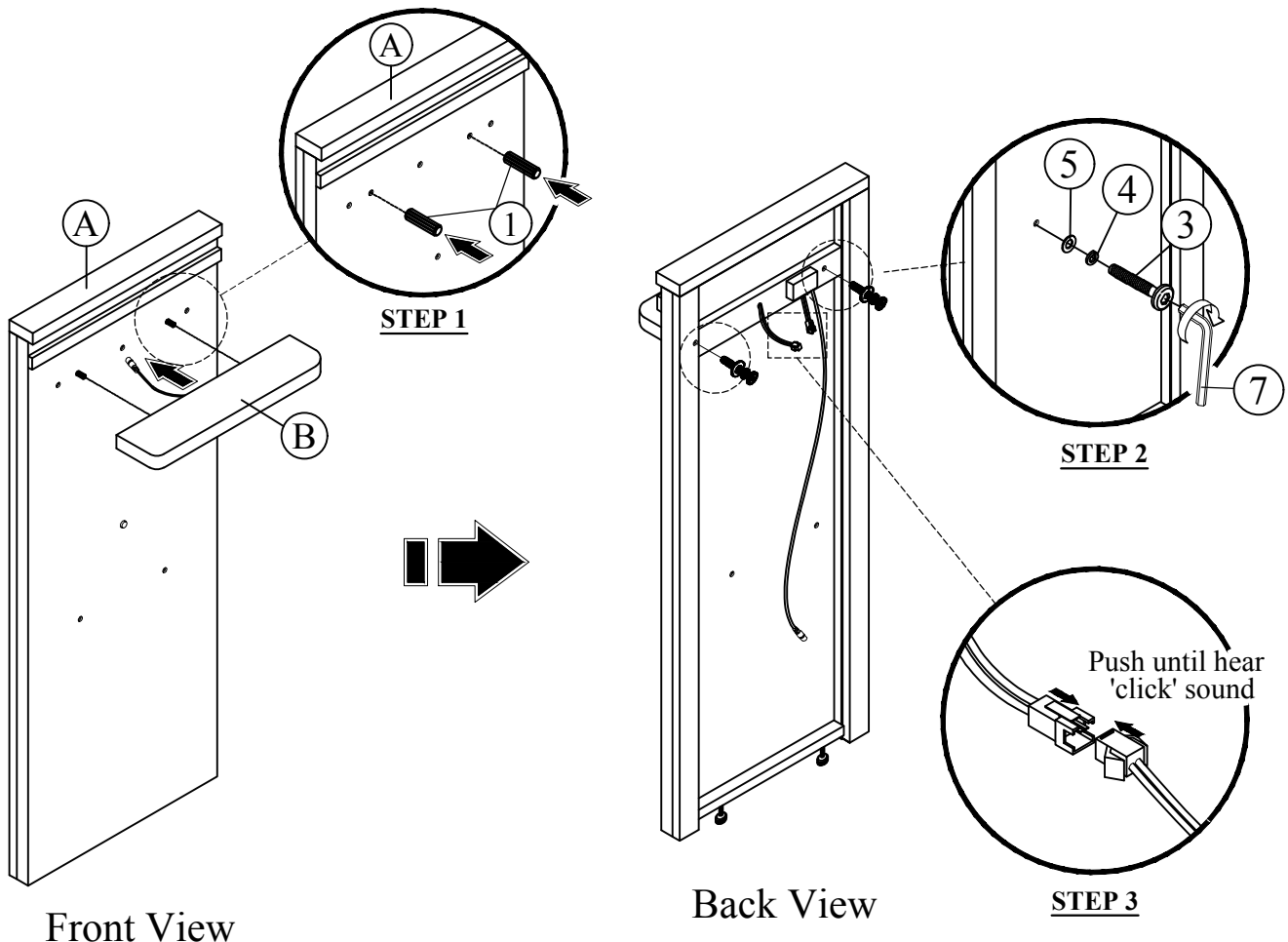

# ASSEMBLY INSTRUCTION

DESCRIPTION : PIER - LEFT AND RIGHT, WHITE LED LIGHTS

Thank you for purchasing this quality product. Be sure to check all packing material carefully for small Hardware which may have come loose inside the carton during shipment. Identify and count all Hardware and compare with the Hardware List below.

STEP 4 : Adjust the Adjustable leveller at the bottom of Wall Panel (A) according to ground level.  
STEP 5 : Then, attach Wall Panel (A) to the both side of Bed (D) and tighten using Metal Plate (6) and PH Screw m4 x 16mm (2).

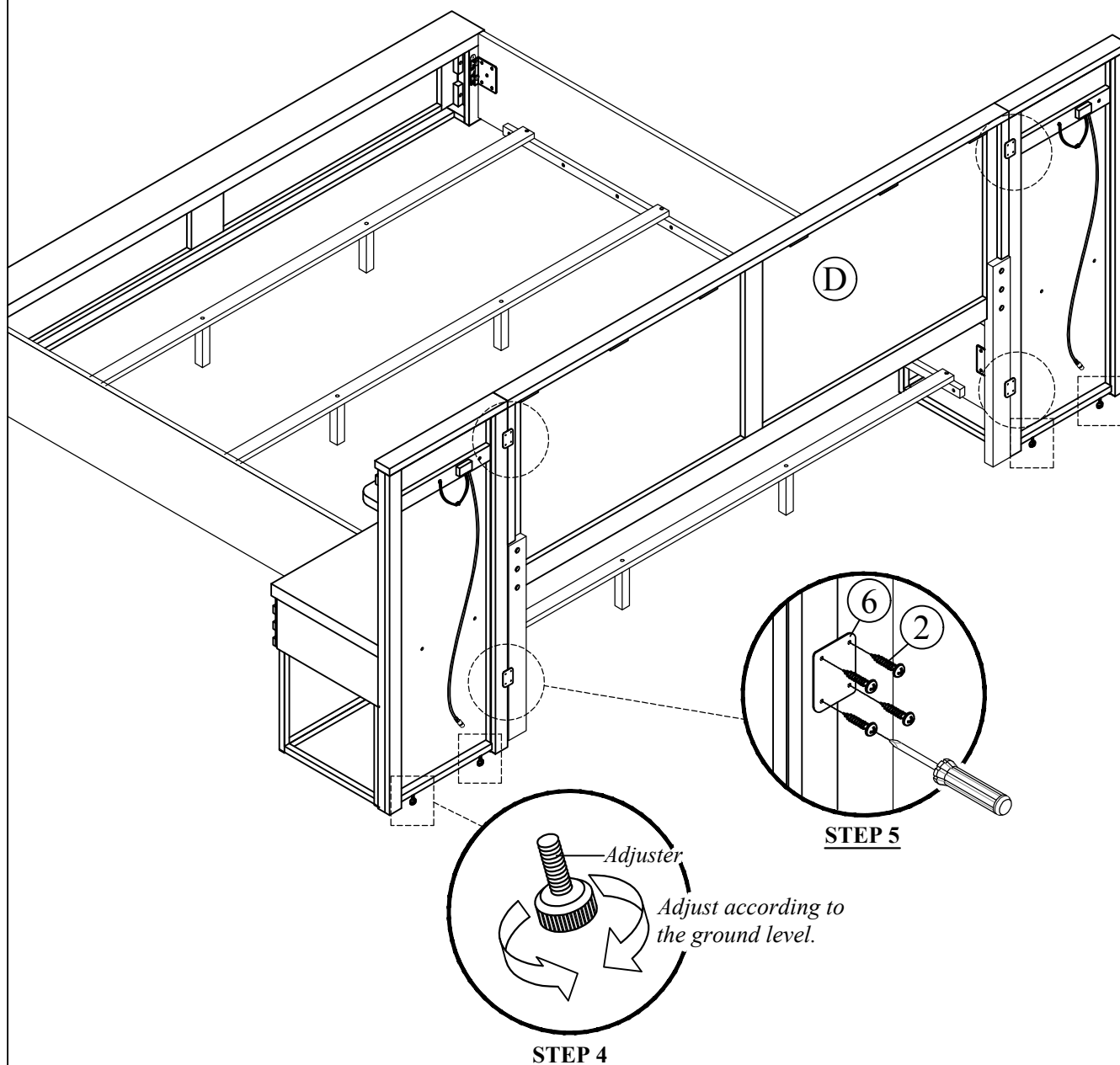

# ASSEMBLY INSTRUCTION

DESCRIPTION : PIER - LEFT AND RIGHT, WHITE LED LIGHTS

Thank you for purchasing this quality product. Be sure to check all packing material carefully for small Hardware which may have come loose inside the carton during shipment. Identify and count all Hardware and compare with the Hardware List below.

STEP 6 : Attach Nightstand (C) to Wall Panel and tighten by using JCBC M6 x 30mm (3), Spring washer (4), Flat washer (5) and Allen key M4 (7).

STEP 7 : Then, connect incoming power head from connector box to DC Adapter (9) before switch ON the power supply for Shelf Light.

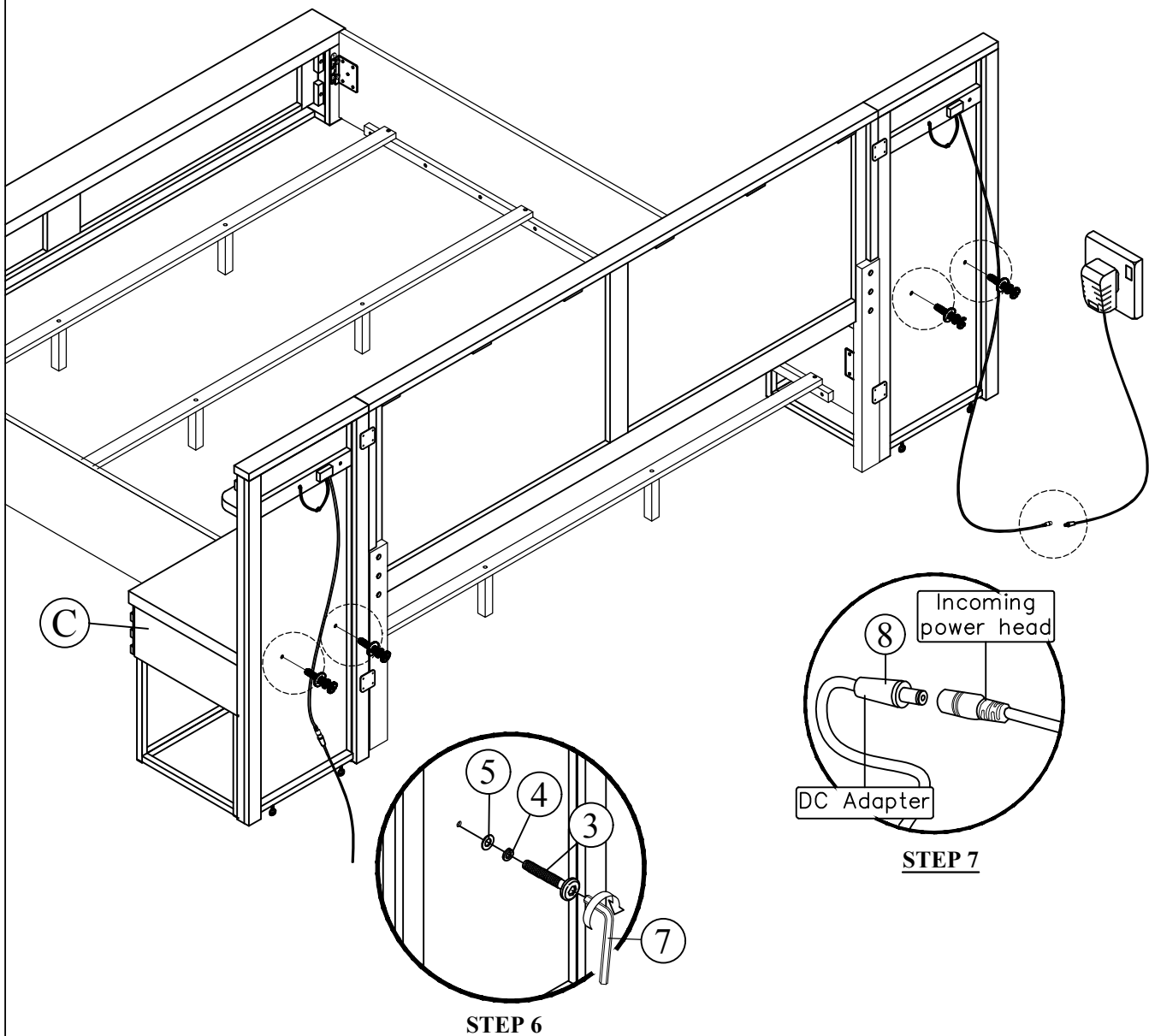

# ASSEMBLY INSTRUCTION

DESCRIPTION : PIER - LEFT AND RIGHT, WHITE LED LIGHTS

Thank you for purchasing this quality product. Be sure to check all packing material carefully for small Hardware which may have come loose inside the carton during shipment. Identify and count all Hardware and compare with the Hardware List below.

