







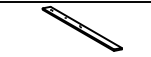

(3' Twin, 4'6" Full, 5' Queen)

Assembly Instruction

A		3 pcs
B		1 pc
C		2 pcs
D		2 pcs
E		2 pcs
F		4 pcs
G		4 pcs
H		1 pc
I		13 pcs
J		8 pcs
K		1 pc
L		1 pc
M		12 pcs
N		4 pcs
O		9 pcs
P		9 pcs
Q		4 pcs

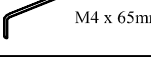
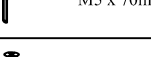
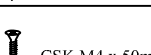
Step 1: Tighten the headboard legs (D) and headboard support wood (H) to the headboard (A) as shown. Tighten the footboard legs (E) to the footboard (B) as shown.

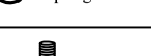
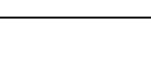
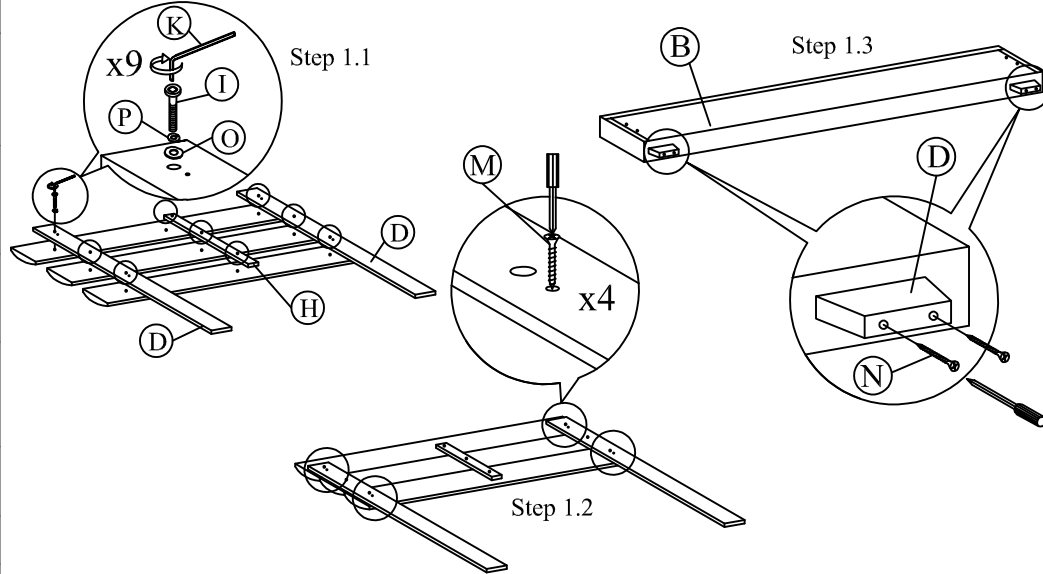

Step 2: Attach side rail (C) to headboard (A) and footboard (B) by pushing the bracket down to fit it.

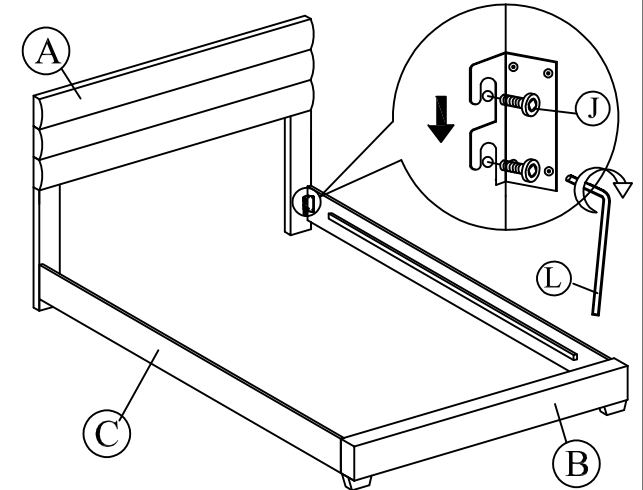

Step 3 Attach the support legs (F) to the slats (G).

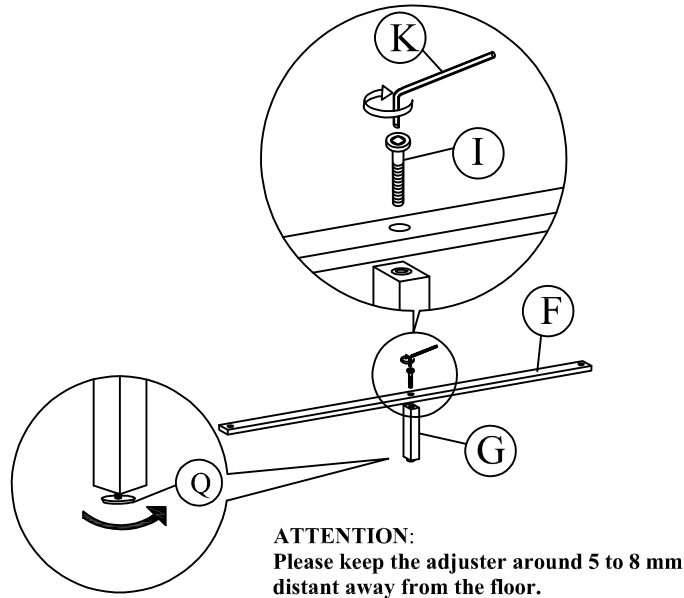

Step 4: Tighten the 4 Corner with allen key (L). Install the bed slats to side rail. Tighten the slats with CSK screw (M). The distance of the slats should be sufficient to obtain desirable bed stability.

