

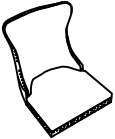



ASSEMBLY INSTRUCTIONS

Ax1	
	Seat
Bx2	
	Front leg
Cx2	
	Back leg
Dx2	
	Adjust the foot
Ex4	 M8*60mm
	Screw
Fx4	 M8*50mm
	Screw
Gx8	 M8
	Spring washer
Hx8	 M8*22mm
	Flat washer
Ix1	 M8
	Allen key

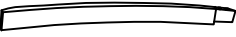

WARNING:

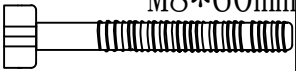
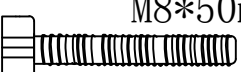
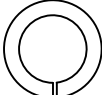
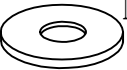
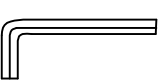
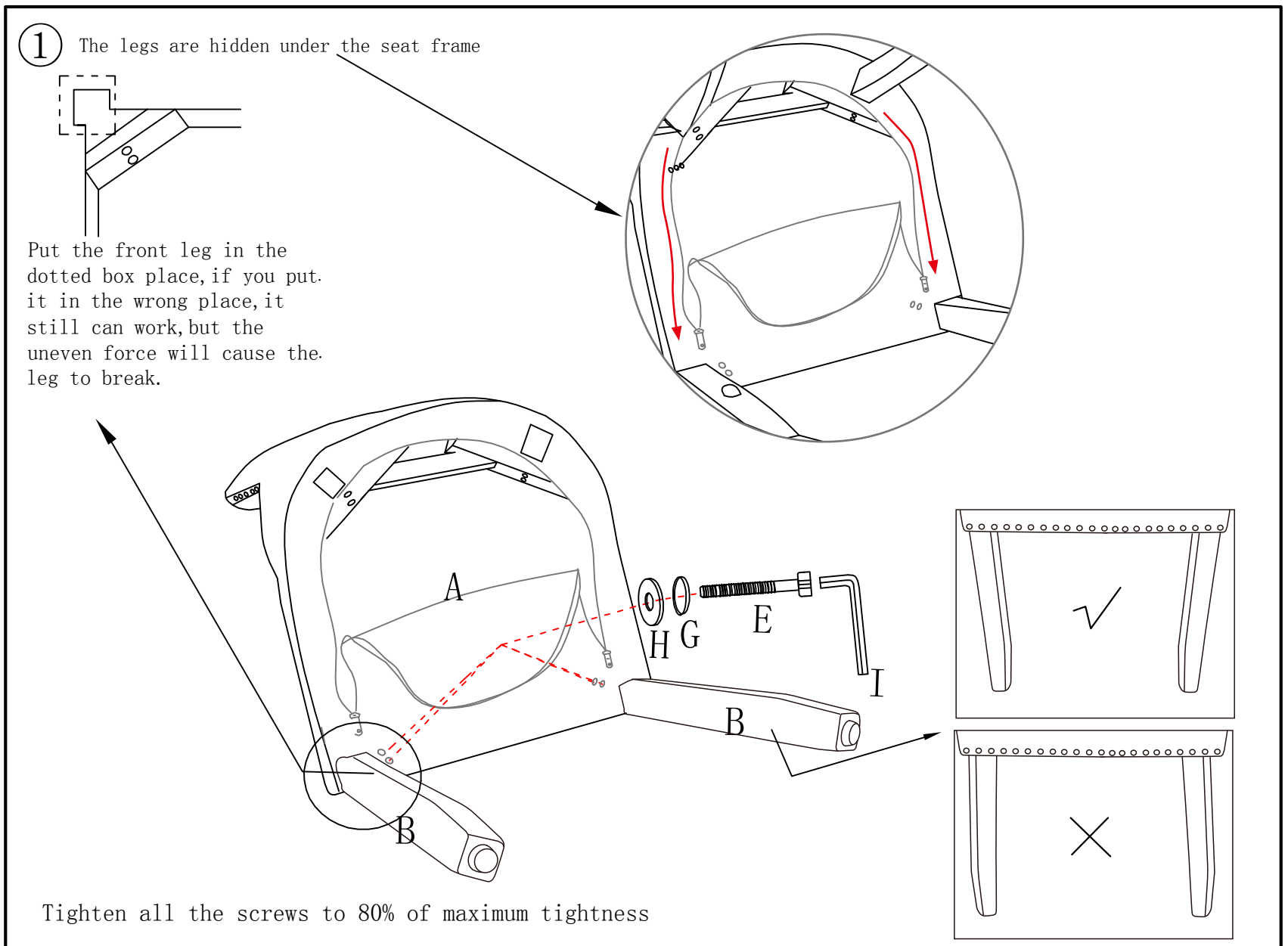
DO NOT STAND ON THE PRODUCT, DO NOT USE THIS PRODUCT AS A STEP LADDER.
 DO NOT USE THIS PRODUCT UNLESS ALL BOLTS, SCREWS AND KNOBS ARE FIRMLY SECURED.
 PLEASE DO NOT USE KNIFE TO OPEN ANY PARTS OF THE BOX OR PRODUCT.

②

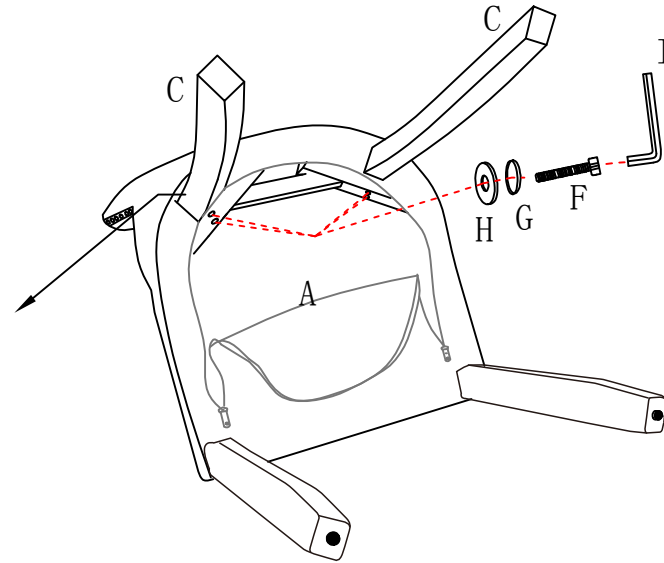
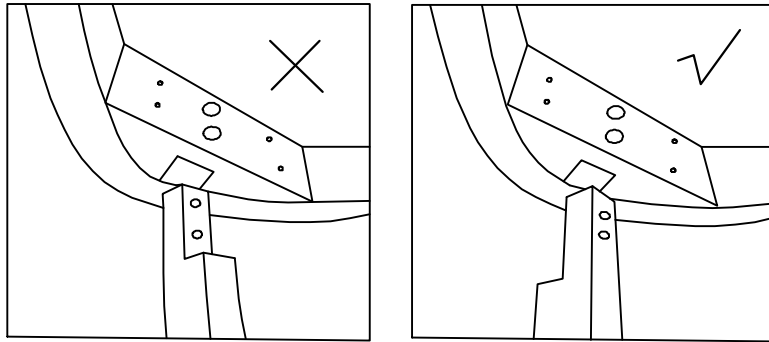

Tighten all the screws to 80% of maximum tightness

③

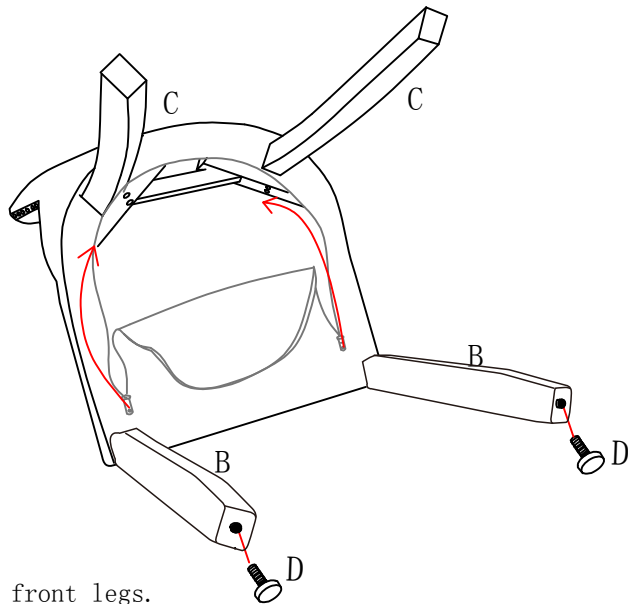

1. screw D into front legs.
2. Carefully sit on the chair and make adjustments to ensure the legs are flat even on the floor.
3. Tighten all the screws to 100% of maximum tightness
4. Close the zipper of bottom Non-Woven fabric.

④

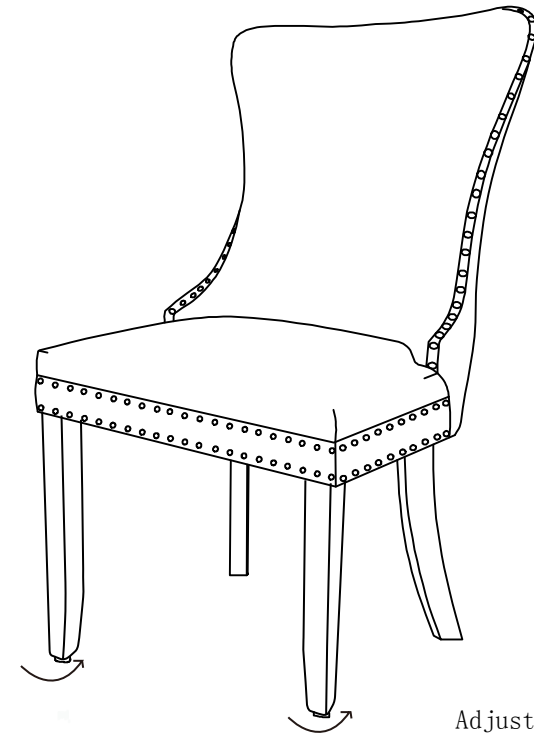

Adjust the adjuster bolt to keep the chair level again