

# ASSEMBLY INSTRUCTIONS

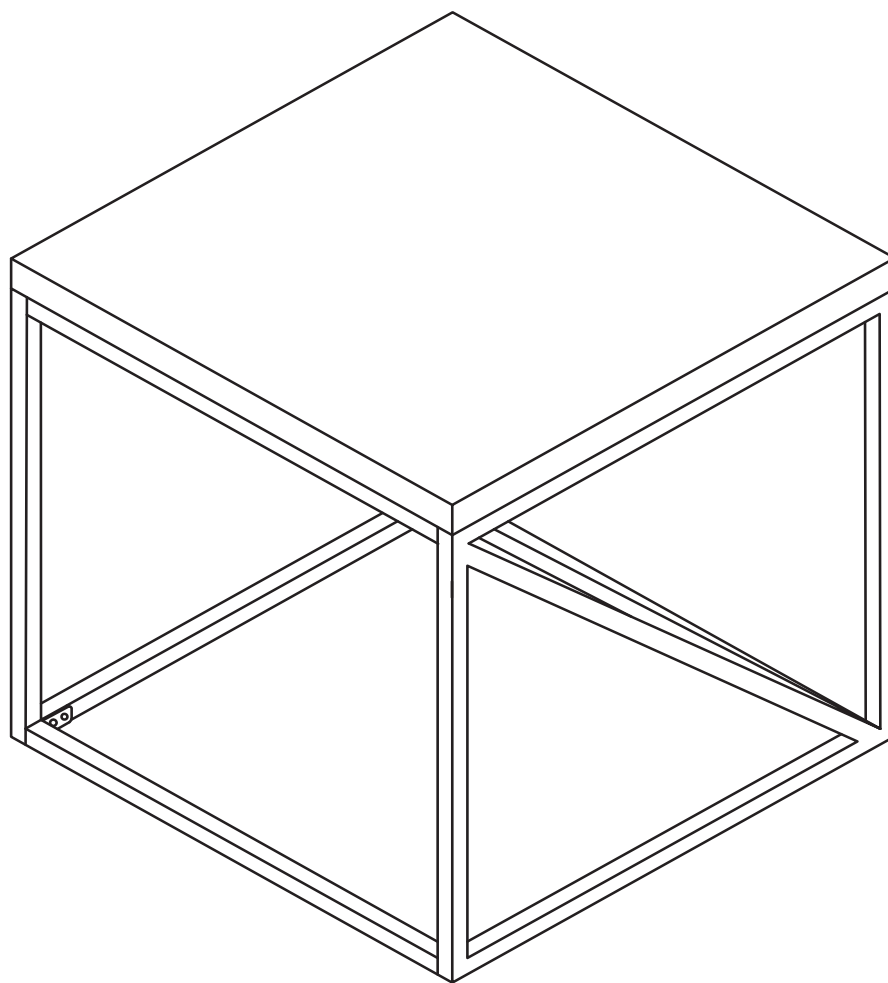

**End Table**

# ASSEMBLY INSTRUCTIONS

## ASSEMBLY TIPS:

1. Remove hardware from box and sort by size.
2. Please check to see that all hardware and parts are present prior to start of assembly.
3. Please follow attached instructions in the same sequence as numbered to assure fast & easy assembly.



### WARNING!

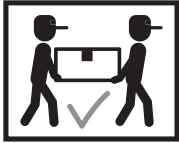

1. Don't attempt to repair or modify parts that are broken or defective. Please contact the store immediately.
2. This product is for home use only and not intended for commercial establishments.



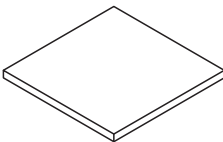
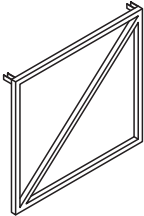
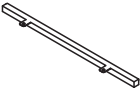

ASSEMBLY TIME

10 MINUTES

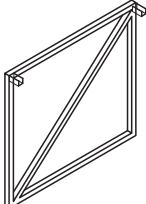
## PARTS IDENTIFICATION

<b>A</b> Top		1 PC
<b>B</b> Right Side Frame		1PC
<b>C</b> Top Crossbar		2 PCS
<b>D</b> Bottom Crossbar		2 PCS
<b>E</b> Left Side Frame		1PC

# HARDWARE IDENTIFICATION

	DESCRIPTION	FIGURE	Q'TY
1	Short Bolt (M6x12MM)		20 PCS
2	Allen wrench (M4)		1 PC

# ASSEMBLY INSTRUCTIONS

## STEP 1

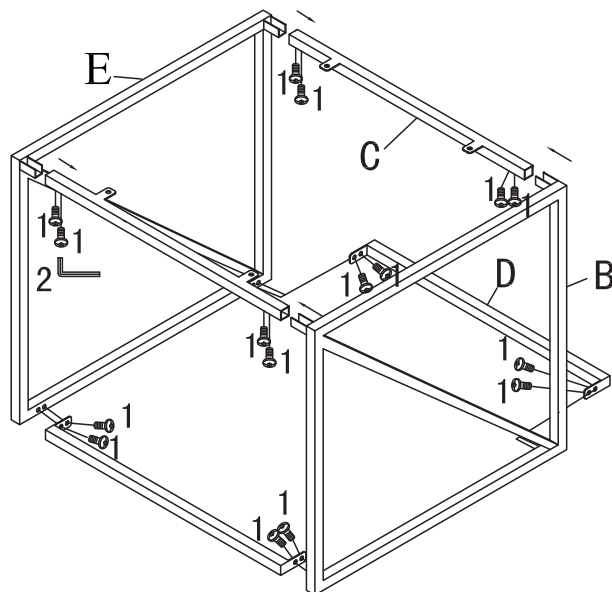

---

## STEP 2

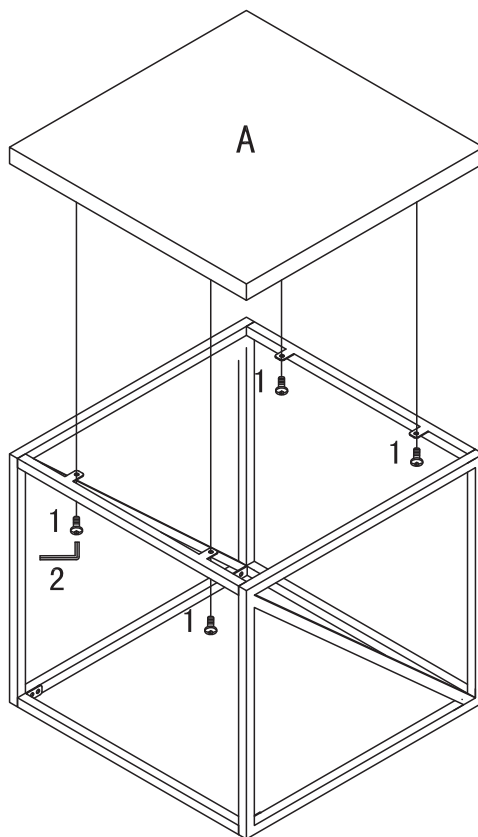

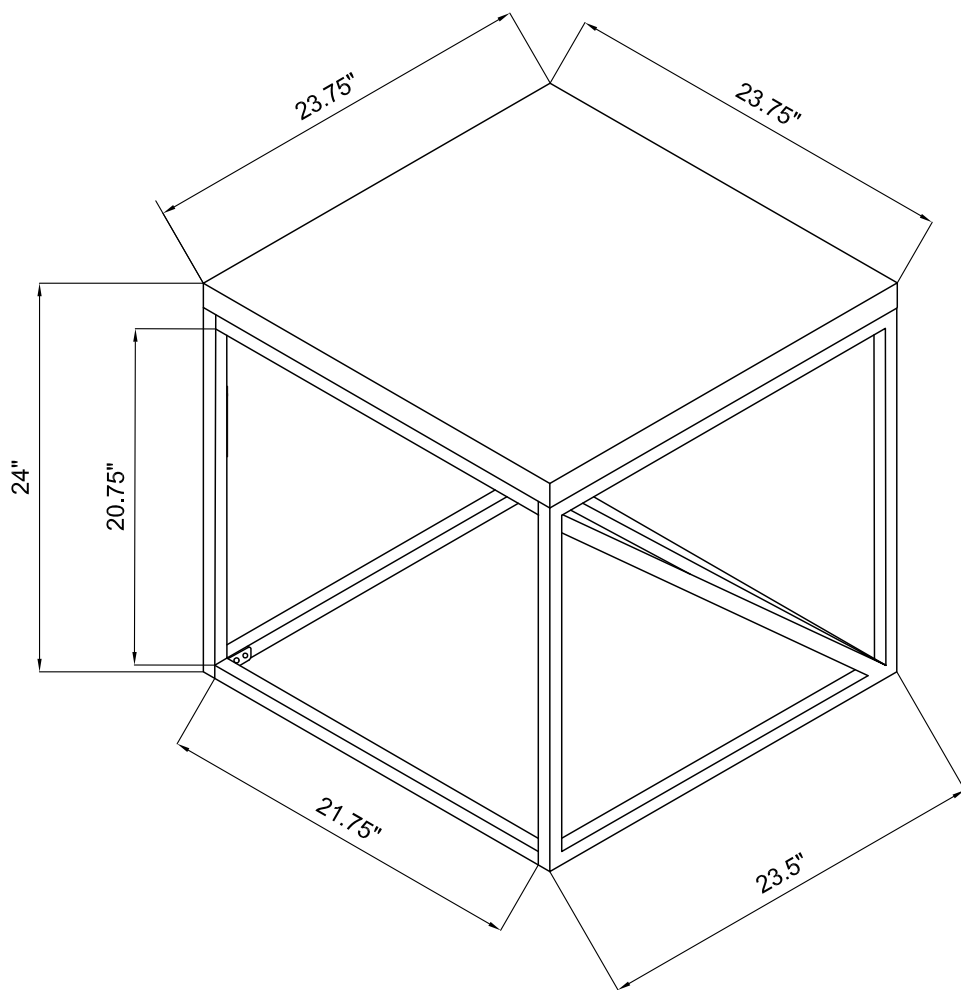

Note: Dimension tolerance  $\pm 5\%$