

## NOTICE

\*Please make sure that you have all parts indicated and they are in good condition before you begin assembly of this item. Refer to part list and hardware list below for guidance.

\*This item should be assembled on a soft surface to prevent scratching the finish during assembly.

\*This item may require periodic tightening.

\*If you are having difficulty, our friendly Customer Care team is always here to help.

## PREPARATION

\*Before beginning assembly of product, make sure all parts are present. Compare parts with part contents list and hardware contents list.

\*If any part is missing or damaged, do not attempt to assemble the product.

\*Estimated Assembly Time: 60 minutes.

\*Tools Required for Assembly (included): Allen Key

## CARE AND MAINTENANCE

Always use felt pads under all articles to prevent discoloration or softening of the lacquer. Plastic and rubber bases on items can discolor wood. Wipe up spills immediately and avoid common hazards such as hot dishes, harsh solvents and abrasives. Cleaning should be done with a soft lint free cotton cloth dampened with water or furniture polish. On highly used surfaces we recommend applying a quality paste wax which should be used on a regular basis to provide additional protection from scratches and spills. How often you apply the wax depends on how much wear the furniture receives.

### Part List

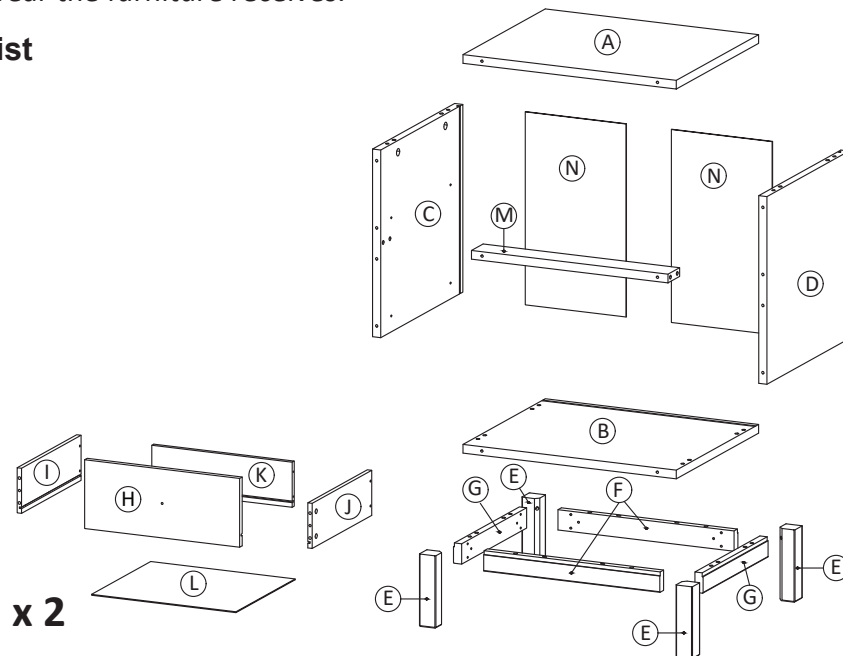



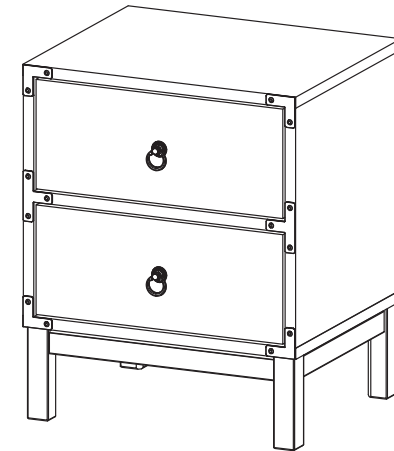





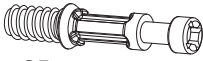



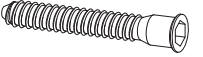

**Product Dimensions: 19"Wx15"Dx23"H**

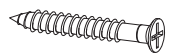

**WARNING :**  
WEIGHT CAPACITY: 26.4 LBS.  
DRAWER LOAD CAPACITY 22 LBS

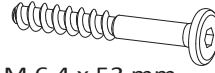
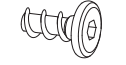
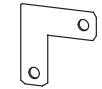
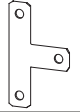
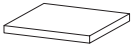
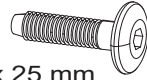
## Hardware List

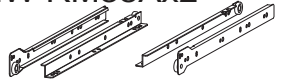
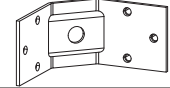
<p>HW1x12</p>  <p>Ø 6 x 35 mm</p>	<p>HW2x4</p>  <p>Ø 15 mm</p>	<p>HW3x8</p>  <p>Ø 12 mm</p>	<p>HW4x20</p>  <p>Ø 8 x 30 mm</p>	<p>HW5x4</p>  <p>Ø 6 x 30 mm</p>	<p>HW6x4</p>  <p>M 7 x 50 mm</p>
<p>HW7x1</p>  <p>L 4</p>	<p>HW8x24</p>  <p>M 4.5 x 12.5 mm</p>	<p>HW9x8</p>  <p>M 6 x 10.5 mm</p>	<p>HW10x12</p>  <p>M 3.5 x 13 mm</p>	<p>HW11x8</p>  <p>M 8 x 39 mm</p>	<p>HW12x14</p> 
<p>HW13x14</p>  <p>M 3.5 x 15.5 mm</p>	<p>HW14x2</p> 	<p>HW15x2</p>  <p>M 4 x 20 mm</p>	<p>HW16x8</p>  <p>M 6.4 x 53 mm</p>	<p>HW17x14</p>  <p>M 6.4 x 14 mm</p>	<p>HW18x4</p> 
<p>HW19x2</p> 	<p>HW20x4</p> 	<p>HW21x4</p>  <p>M 6 x 25 mm</p>	<p>HW22x1</p> 	<p>HW RM35Ax2</p>  <p>350 mm</p>	<p>HW BC410x4</p> 

## Part List & HW For Multi-Box Items

Piece	Description	Qty	Carton Call
A	Top Board	1	1 of 1
B	Bottom Board	1	1 of 1
C	Side Board Left	1	1 of 1
D	Side Board Right	1	1 of 1
E	Leg	4	1 of 1
F	Bottom Skirt 1	2	1 of 1
G	Bottom Skirt 2	2	1 of 1
H	Front Drawer	2	1 of 1
I	Side Drawer Left	2	1 of 1
J	Side Drawer Right	2	1 of 1
K	Back Drawer	2	1 of 1
L	Bottom Drawer	2	1 of 1
M	Support Board	1	1 of 1
N	Back Board	2	1 of 1

Piece	Description	Qty	Carton Call
HW1	Cambolt	12	1 of 1
HW2	CamLock Big	4	1 of 1
HW3	CamLock Small	8	1 of 1
HW4	Dowel Big	20	1 of 1
HW5	Dowel Small	4	1 of 1
HW6	Screw M 7 x 50 mm	4	1 of 1
HW7	Allen Key	1	1 of 1
HW8	Screw M 4.5 x 12.5 mm	24	1 of 1
HW9	Screw M 6 x 10.5 mm	8	1 of 1
HW10	Screw M 3.5 x 13 mm	12	1 of 1
HW11	Screw M 8 x 39 mm	8	1 of 1
HW12	Wedge	14	1 of 1
HW13	Screw M 3.5 x 15.5 mm	14	1 of 1
HW14	Handle	2	1 of 1
HW15	Screw M 4 x 20 mm	2	1 of 1
HW16	Screw M 6.4 x 53 mm	8	1 of 1
HW17	Screw M 6.4 x 14 mm	14	1 of 1
HW18	Plat "L"	4	1 of 1
HW19	Plat "T"	2	1 of 1
HW20	Floor Protector	4	1 of 1
HW21	Screw M 6 x 25 mm	4	1 of 1
HW22	List Joint	1	1 of 1
HW RM35A	Rail	2	1 of 1
HW BC410	Corner Brace	4	1 of 1

# PREPARATION

Before beginning assembly of product, make sure all parts are present. Compare parts with part contents list and hardware contents list.  
If any part is missing or damaged, do not attempt to assemble the product.  
Estimated Assembly Time: 45 minutes.

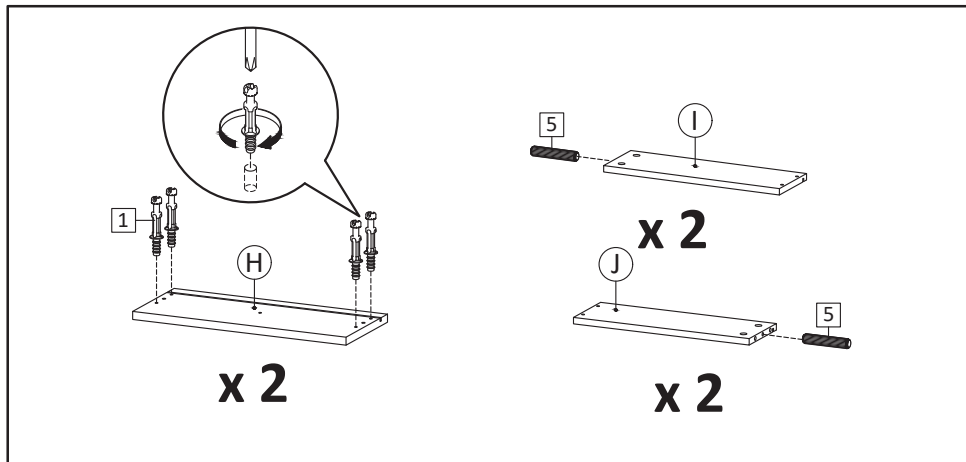

**STEP1:** Insert Cambolt (HW1) into Front Drawer (H).  
Insert Dowel Small (HW5) into Side Drawers ( I & J )

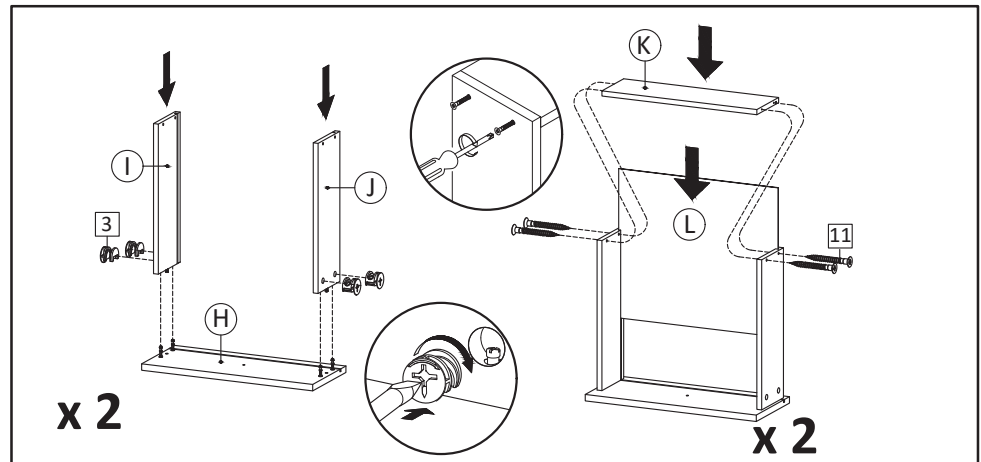

**STEP2:** Combine Side Drawers ( I & J ) into Front Drawer ( H )  
then tighten camlock (HW3) using screwdriver.  
Insert Bottom Drawer ( L ) with laminated face facing upward then  
put Back Drawer ( K ) and secure with Screw M8x39mm (HW11).

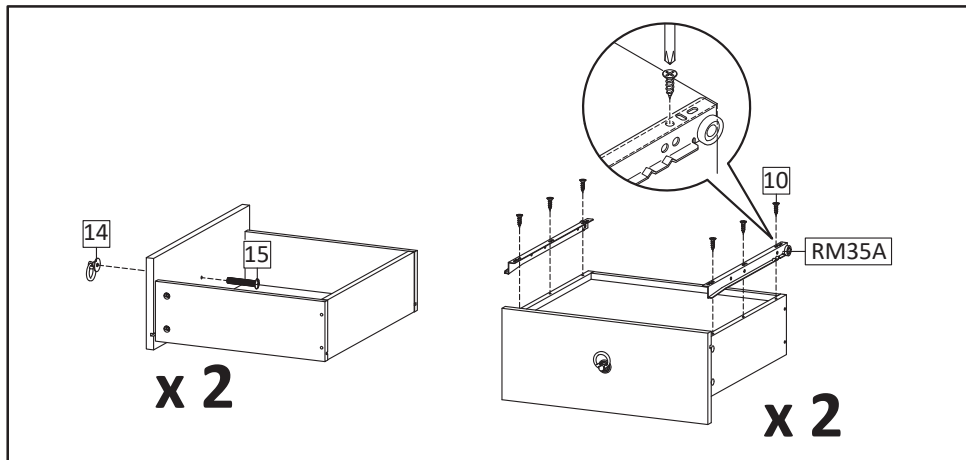

**STEP3:** Use Screw M4x20mm (HW15) to attach Handle (HW14)  
to the Front Drawer.  
Install the metal runner (HW RM35A) into position as shown in picture.  
Secure with screws M3.5x13mm (HW10)

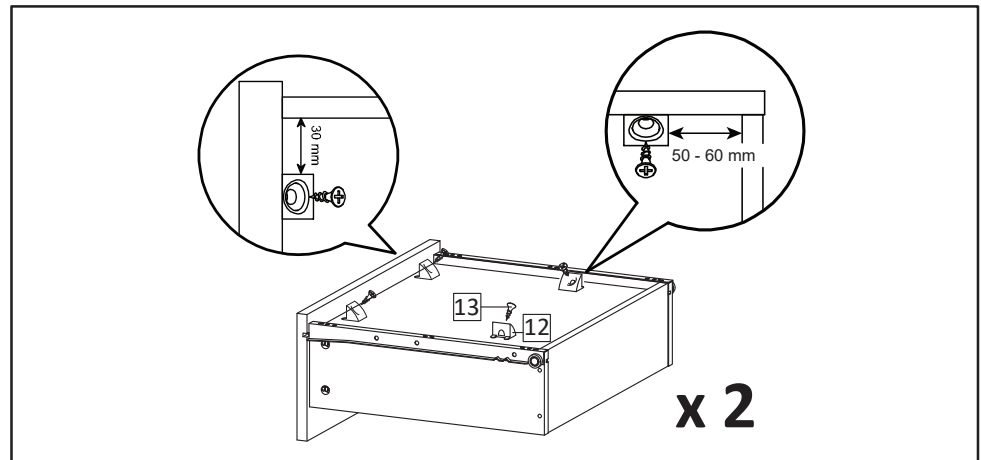

**STEP4:** Insert the Screw M3.5x15.5mm (HW13) and wedge (HW12)  
into the bottom of the drawer according to the picture.

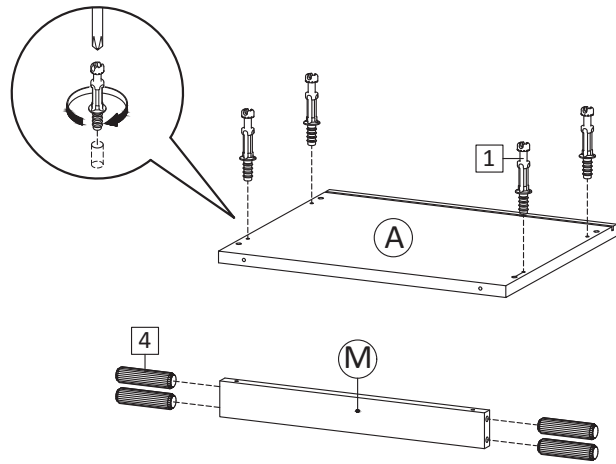

**STEP5:** Insert Cambolt (HW1) into Top Board.  
Insert Dowel Big (HW4) into Support Board (M)

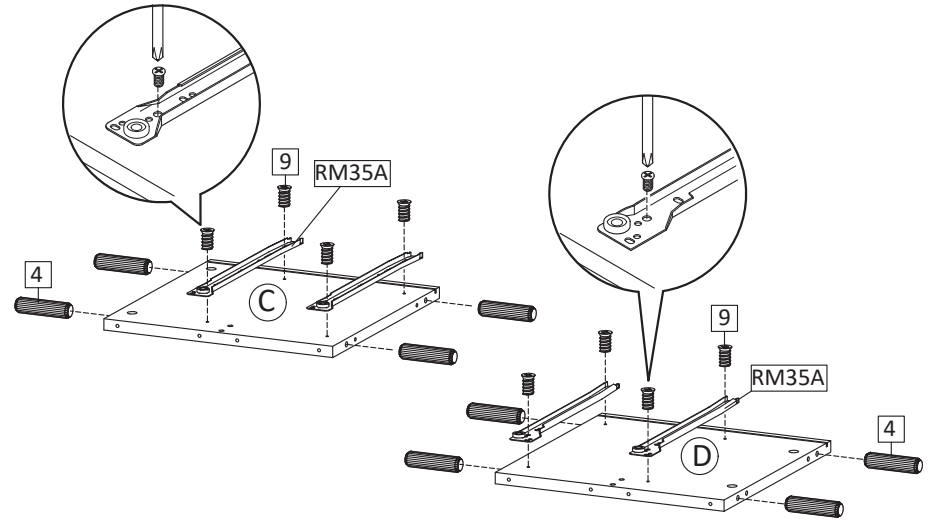

**STEP6:** Insert Dowel Big (HW4) into Side Board Left (C) and Side Board Right (D).  
Continue with securing part of the metal runner (HW RM35A ) into position as the above image, using screw M6x10.5mm (HW9).

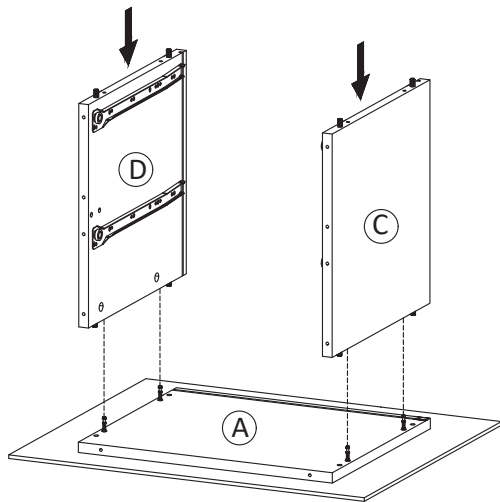

**STEP7:** Attach Side Board Left (C) and Side Board Right (D) into Top Board (A).

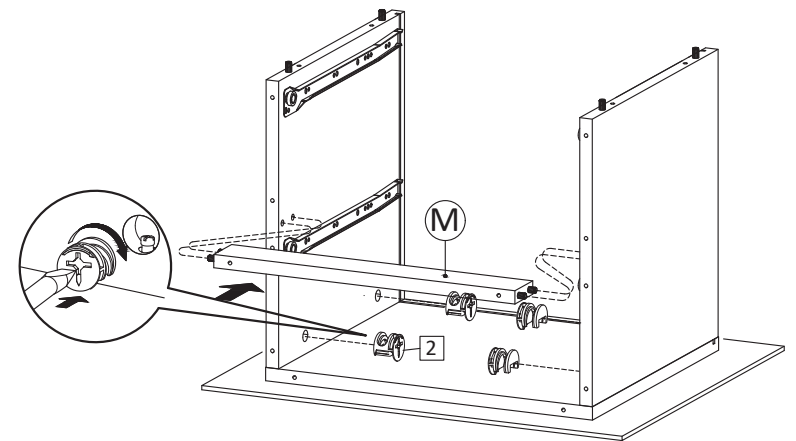

**STEP8:** Attach Support Board (M) Between Side Board Left (C) and Side Board Right (D).  
Secure with Camlock Big (HW2) and tighten it using screwdriver.

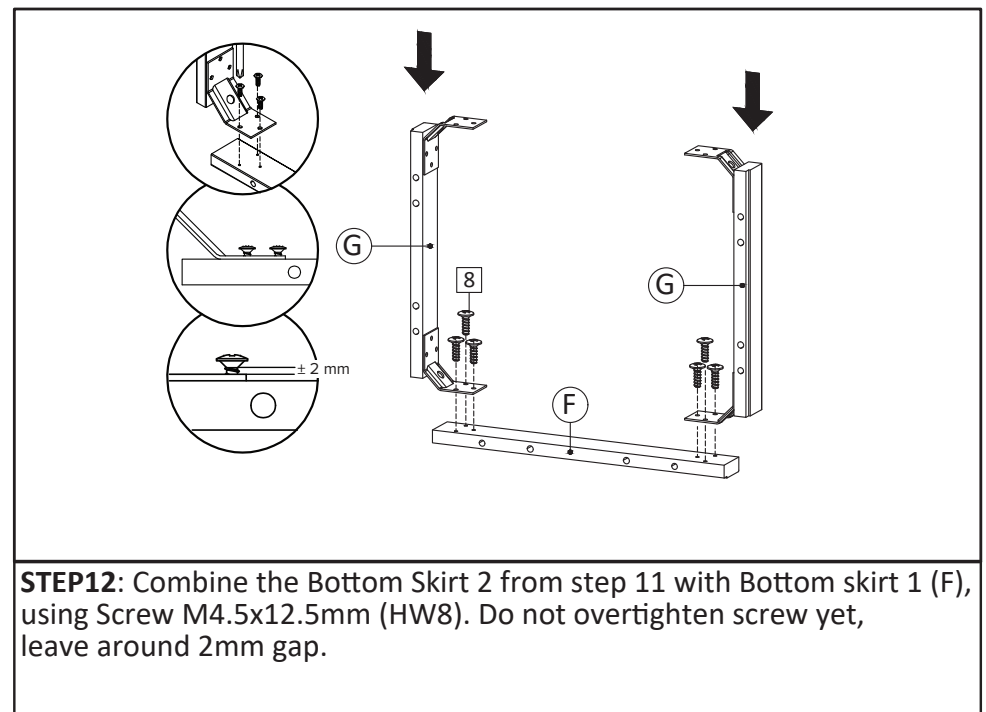
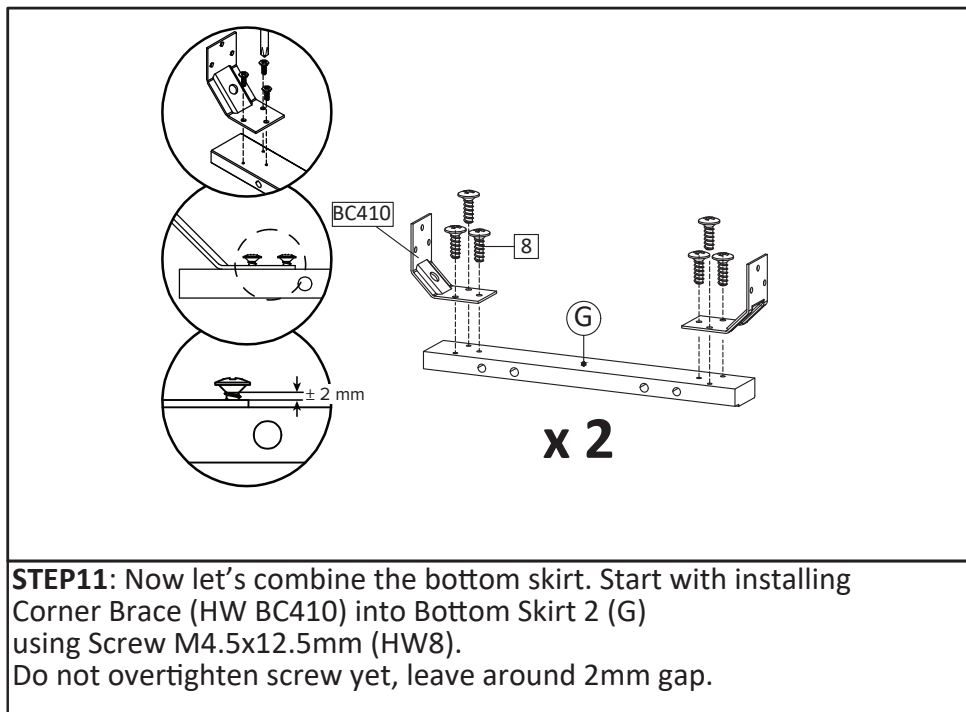
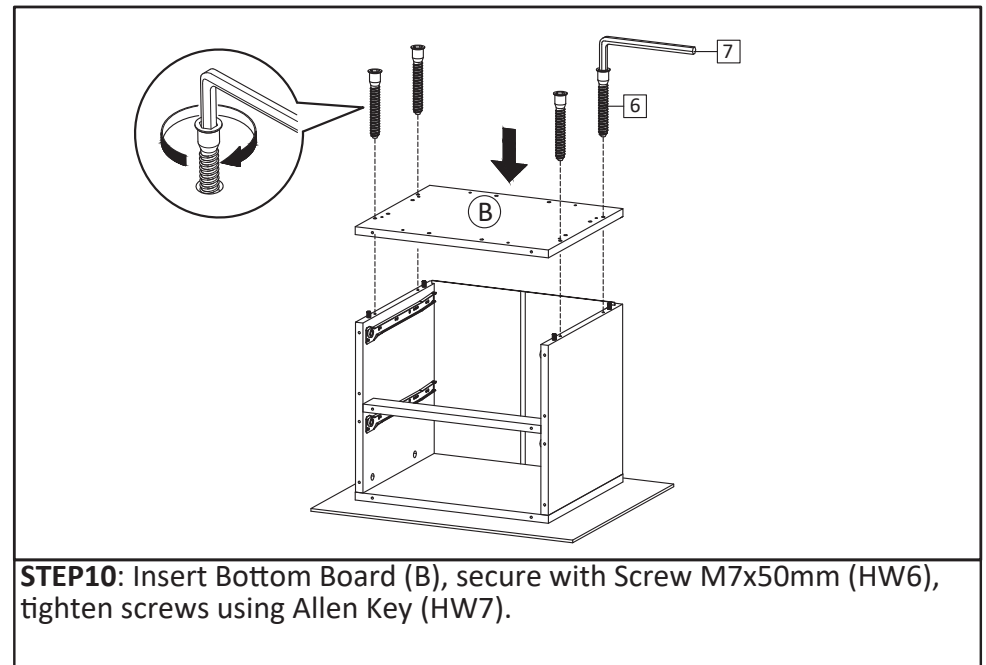
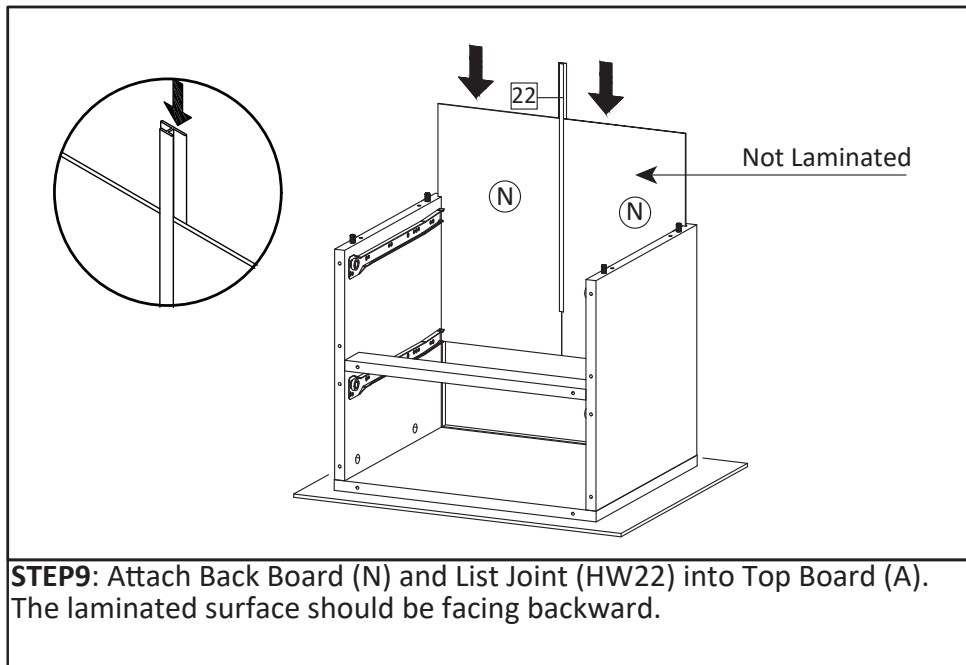

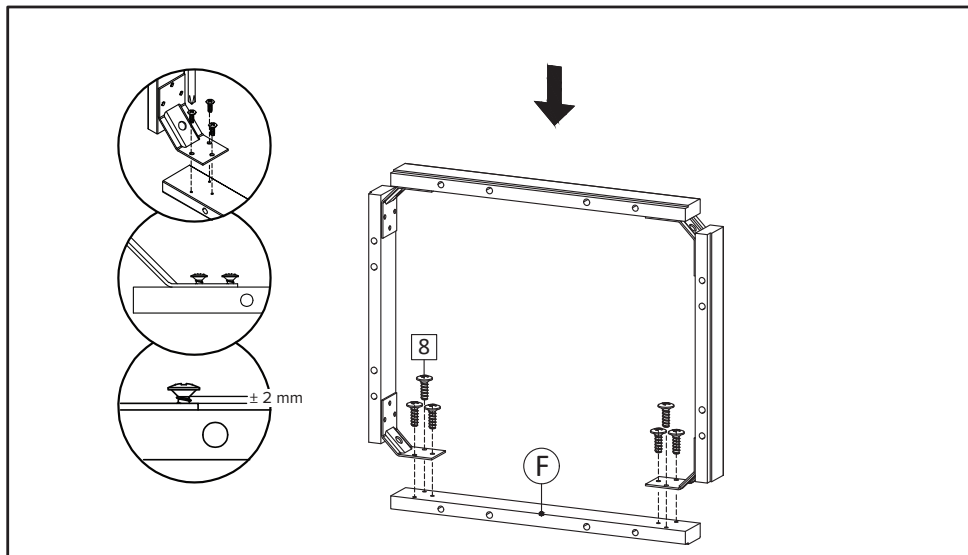

**STEP13:** Combine components from step 12 with remaining Bottom skirt 1 (F), using M4.5x12.5mm (HW8). Do not overtighten screw yet, leave around 2mm gap.

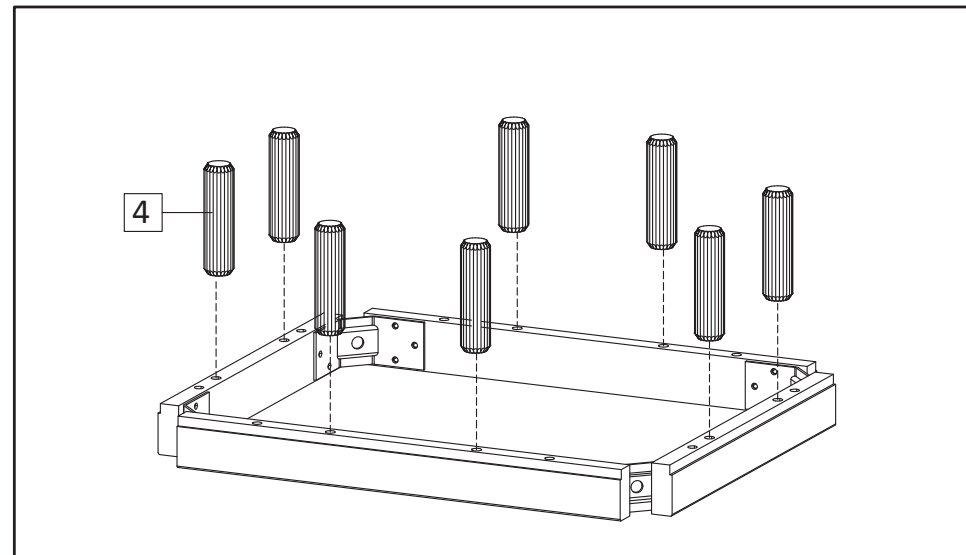

**STEP14:** Insert Dowel Big (HW4) into assembled Bottom skirt from previous step.

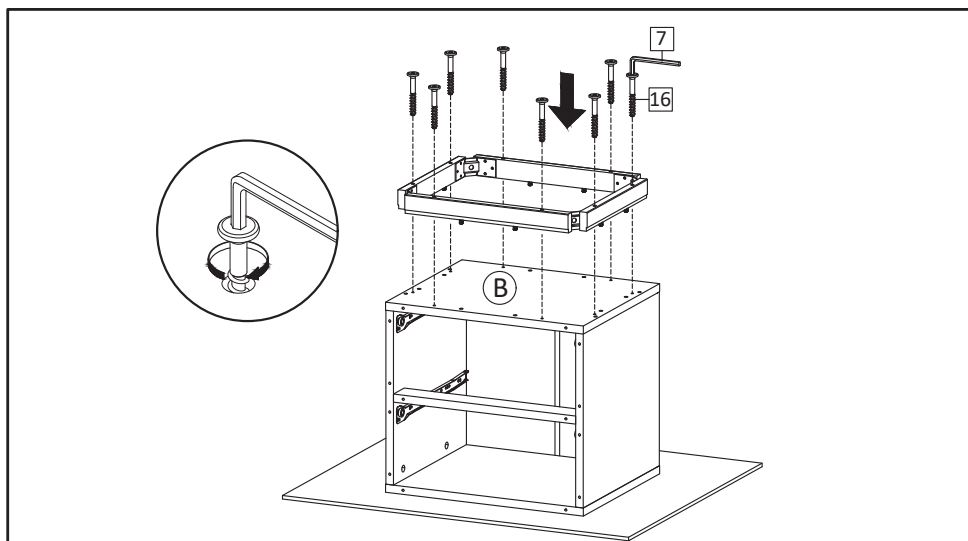

**STEP15:** Bring the assembled bottom skirt and insert into Bottom Board of the chest drawer. Secure the bottom skirt by inserting Screw M6.4x53mm (HW16) and Allen Key (HW7).

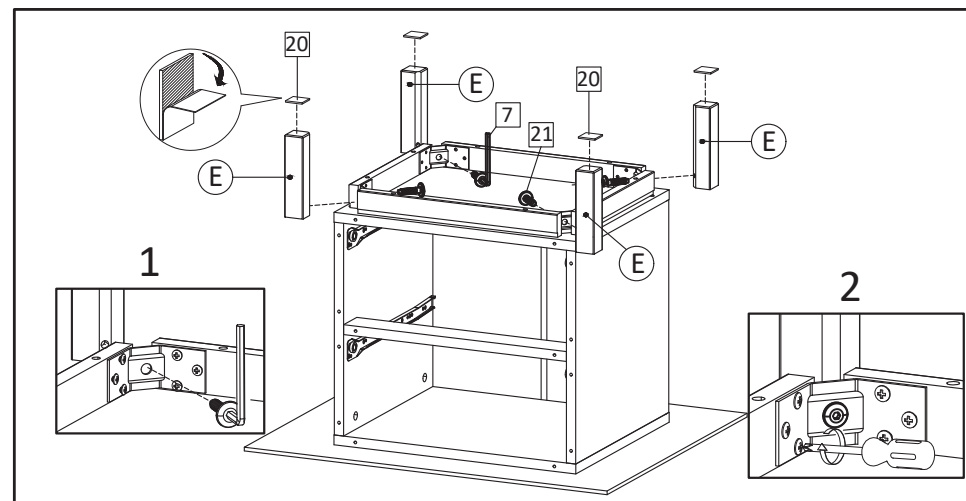

**STEP16:** Place the Leg (E) on the center corner brace and insert the screw M6x25mm (HW21) with Allen Key (HW7) into the leg, then tighten all the screws and remove back paper of the floor protector (HW20) stick to bottom face of the legs.

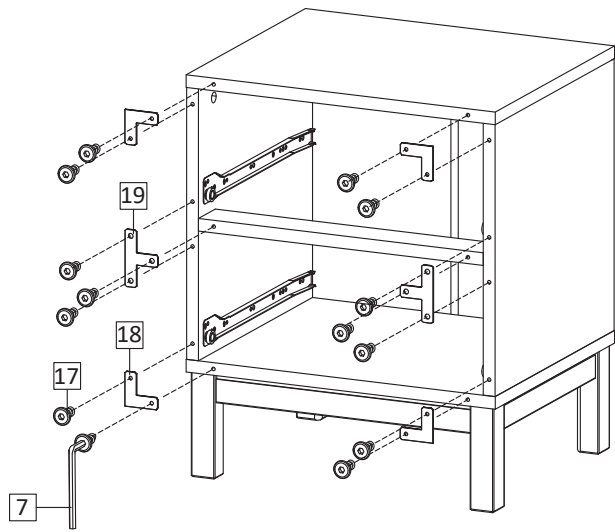

**STEP17:** Bring the chest drawer upright, Install Plat L (HW18), Plat T(HW19) into the provided holes in front edges of the chest drawer. Secure with screw M 6.4x14mm (HW17),tighten using Allen Key (HW7)

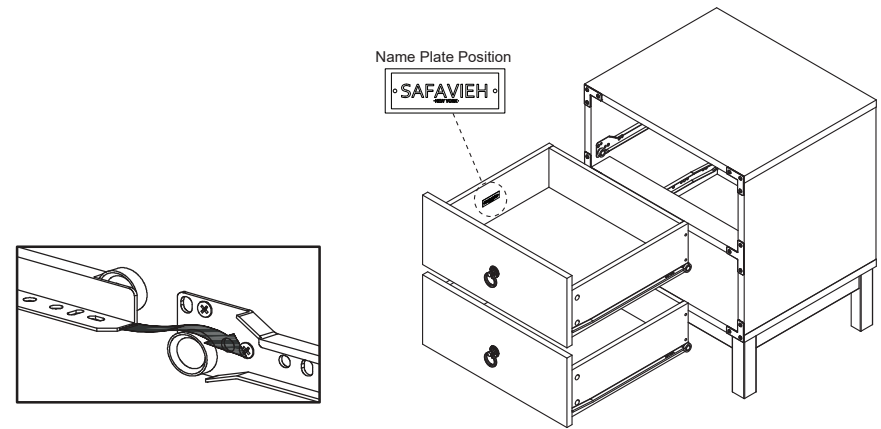

**STEP18:** Hold the sides of drawer, position the wheel of rail at drawer back and the wheel of rail at side boards, according to the image. Slide in the drawers one by one into the chest drawer.

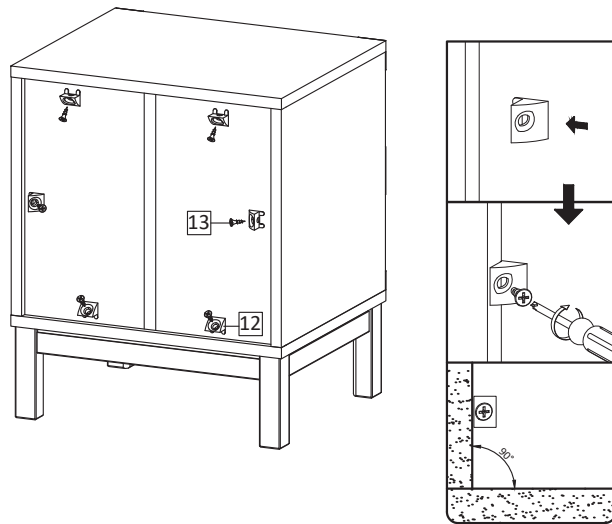

**STEP19:** Use Wedge (HW12), Screw M 3.5 x15.5 (HW13) to tighten the back of chest drawer by using screwdriver. Please align the top board and bottom board in 90° position against the side board, before securing the wedges (HW12)

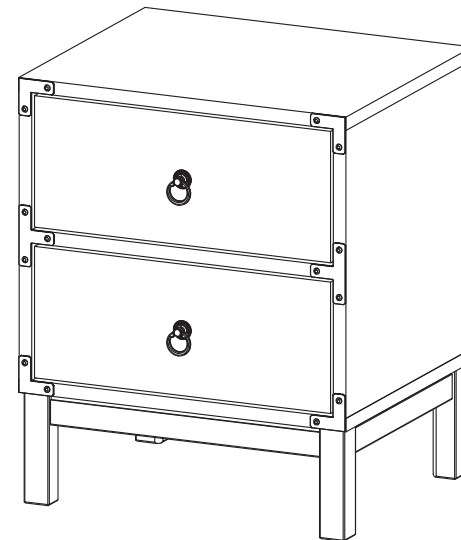

**STEP20:** Assembly is complete

# TIPPING RESTRAINTS KIT INSTALLATION GUIDANCE

Different wall materials require unique wall fasteners.

The wall plugs (AA2) and screws (AA3) are designed for fixing to concrete walls only.

Please consult your local hardware store to ensure you are using the correct hardware for your wall type.

