

# ASSEMBLY INSTRUCTION

## 7097-SOFA

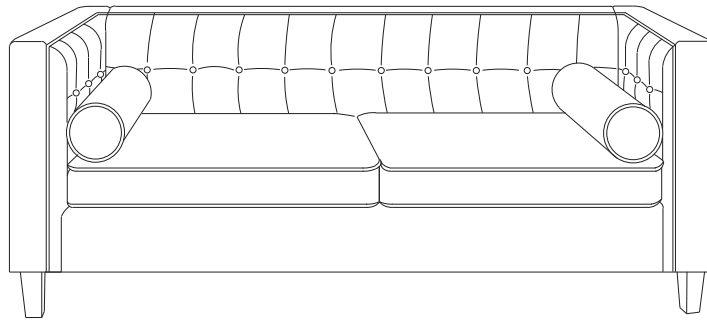

### PARTSLIST

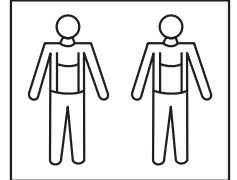
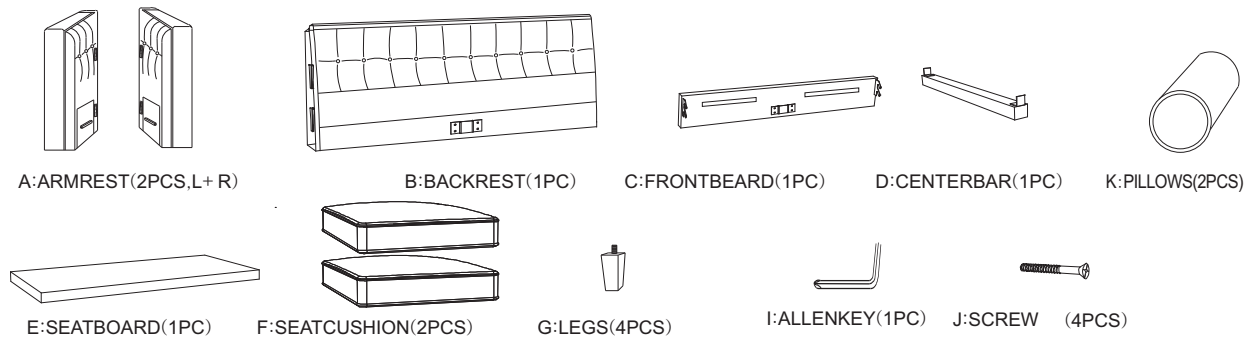

### ASSEMBLY

#### KINDLY REMINDER

K: PILLOWS (2PCS)  
PACKED IN SOFA BACKREST

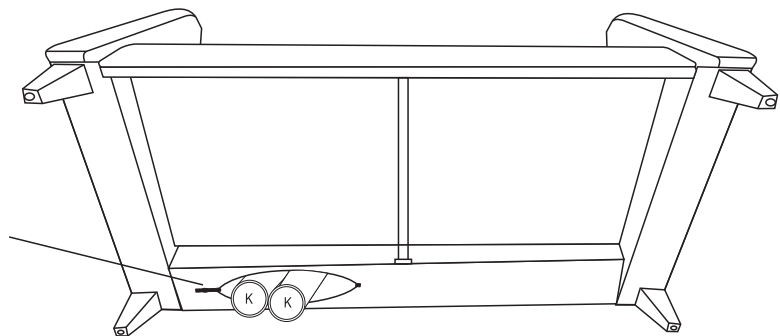

CAREFULLY UNPACK AND PLACE THE SOFA BODY (A) ON A CLEAN FLAT SURFACE TO SHOW THE BASE AS SHOWN.  
UNPACK PARTS FROM THE STORAGE COMPARTMENT

#### STEP 1

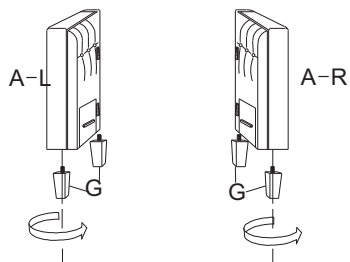

#### STEP 2

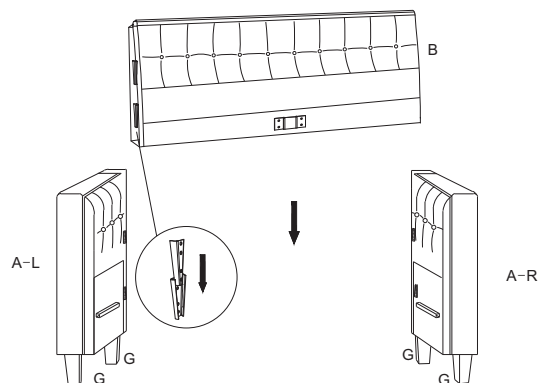

STEP 3

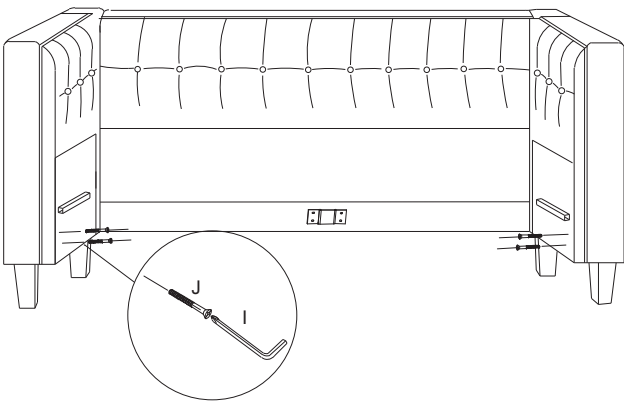

STEP 4

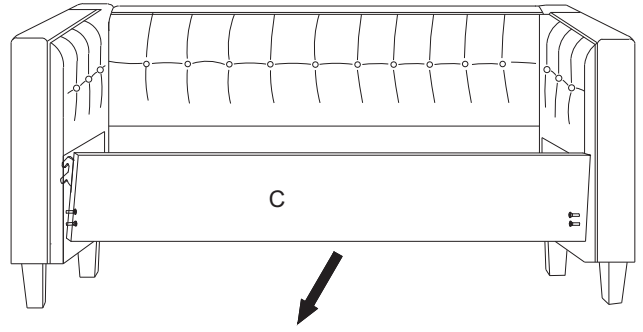

STEP 5

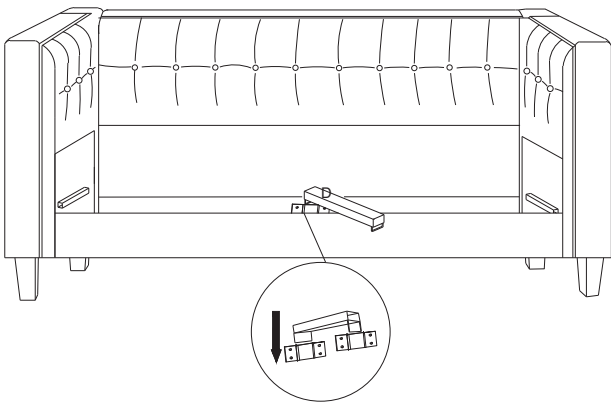

STEP 6

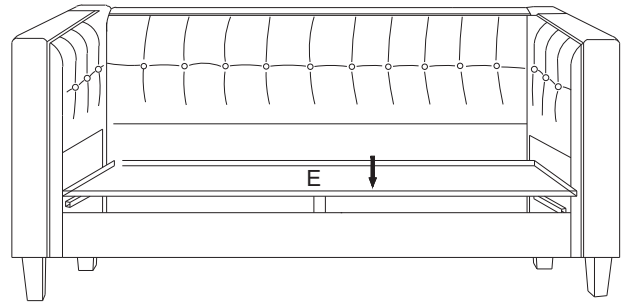

STEP 7

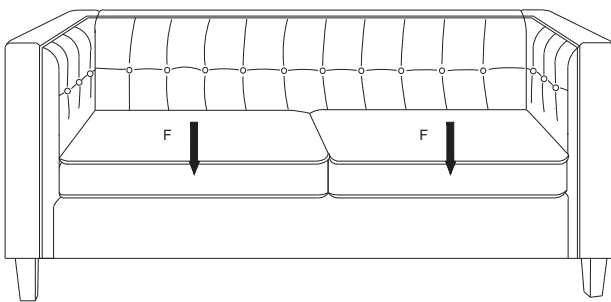

STEP 8

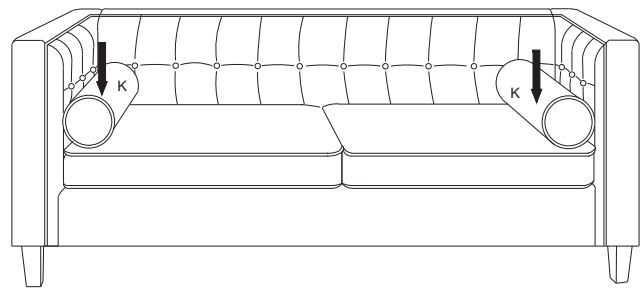

# A quick note...

Your cushions packed under the seat cushion for shipping. To restore the cushion's original shape, follow the steps below.

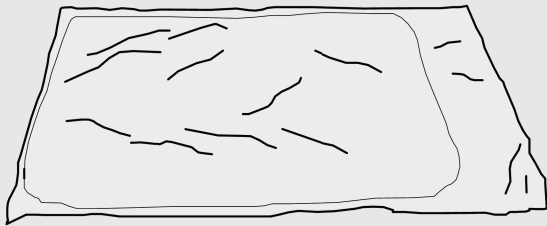

**1.** Pickup under the seat cushion and put the cushion on a flat surface in a well ventilated room and allow **48 hours** for expansion.

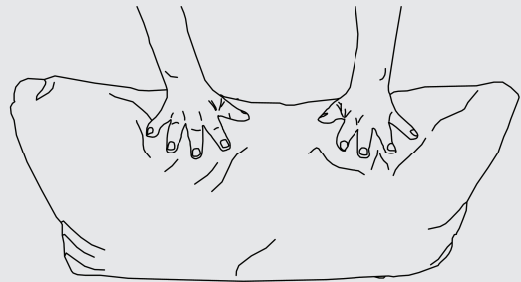

**2.** Press the back cushions with both hands from side edge.

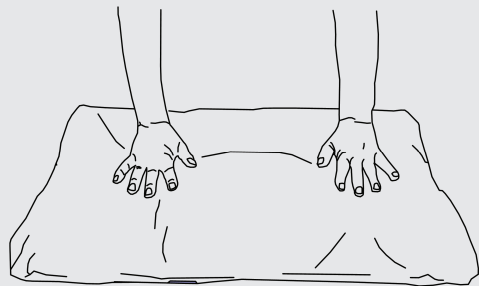

**3.** Press the back cushions with both hands from front side.

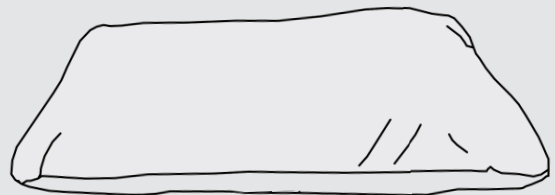

**4.** Complete! Your cushions are reshaped and ready to be placed onto your new furniture piece.

Note: Due to the packaging, it is normal for the customer to receive the product with creases on the back cushions. The customer can use the steam iron to flatten it. When using the steam iron, the temperature should not be too high. Creases are inevitable in the process of product packaging, but they do not affect the use and do not belong to quality problems.