

Storage Cabinet

Instruction Manual



General Assembly Guidelines

- I. Ensure that all parts and hardware are available before beginning assembly.
- II. Follow each step carefully to ensure the proper assembly of this product.
- III. Two people are recommended for ease in the assembly of this product.
- IV. The three main types of hardware used to assemble this product are : wood dowels , screws and bolts.
- V. The provided glue is to secure wood dowels in place . When first inserting dowels , locate the appropriate hole for the dowel , place a small amount of glue in the hole and insert the dowel . Wipe away excess glue immediately.

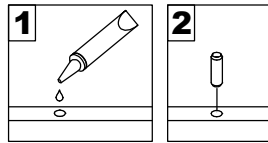

In future assembly steps when dowels are necessary to attach assembly parts together , place a small amount of glue on the end of the dowel before attaching parts together . Wipe away excess glue immediately.

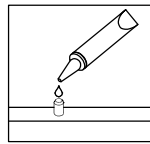

- VI. A Phillips head screwdriver is required for the assembly of this product .

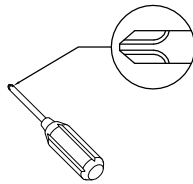

- VII. Power tools should not be used to assemble this product .

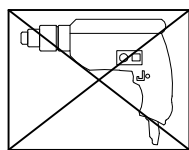

- VIII. Concealed hinges are three-way adjustable.

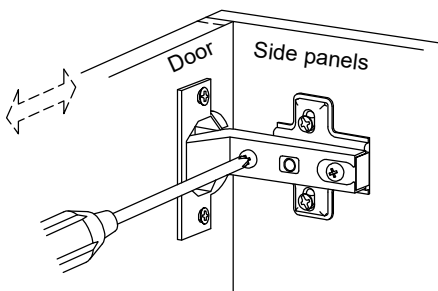

Horizontal
by screw adjustment

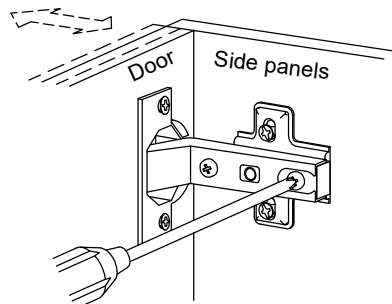

In-and-Out
by loosening the hinge-arm
mounting screw or via cam
adjustment

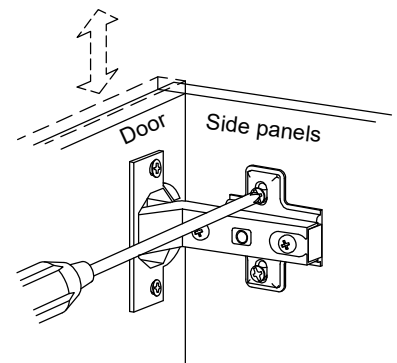

Vertical
Via slots in the mounting
plate or via cam adjustment

Exploded Drawing

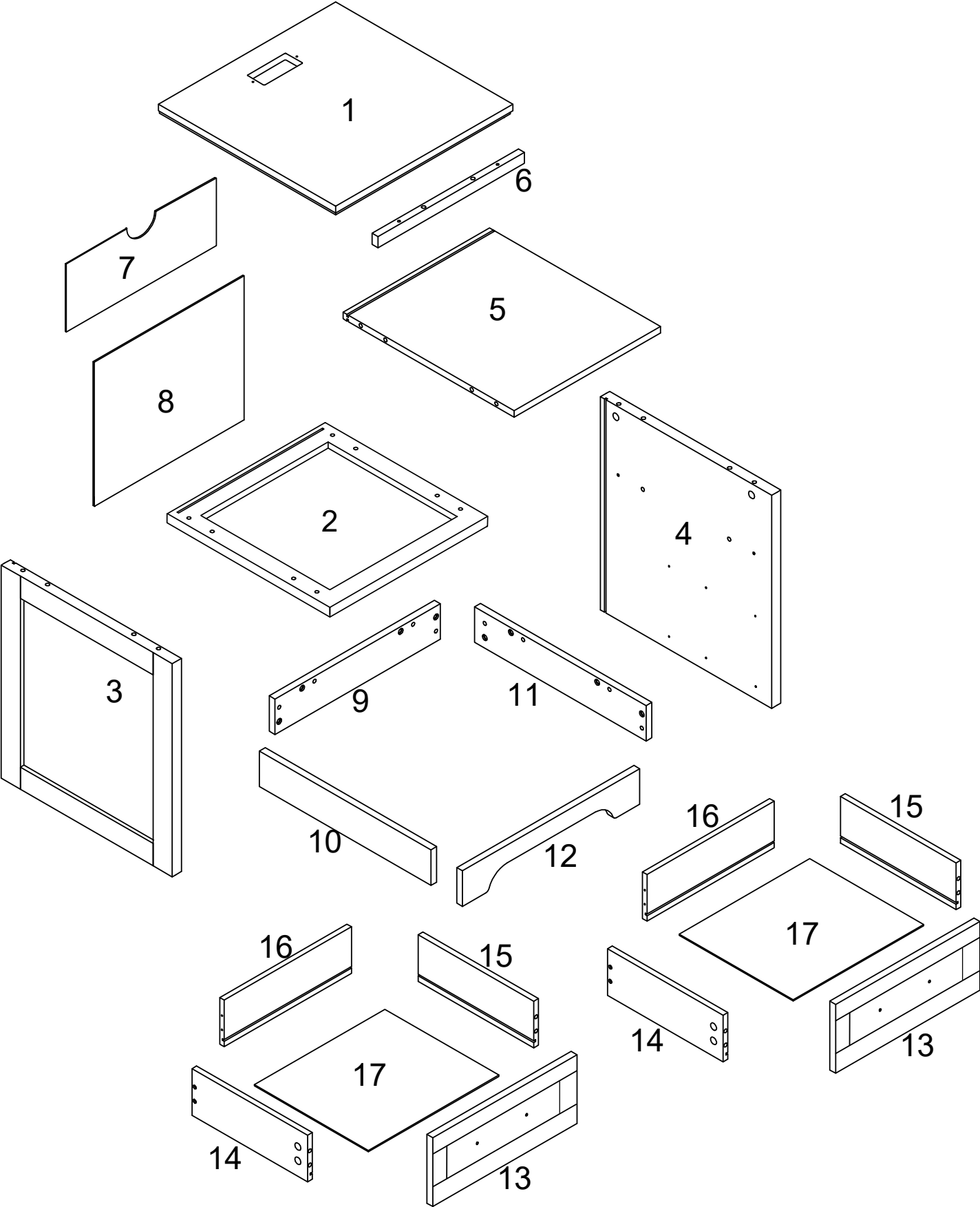

Supplied Parts and Hardware

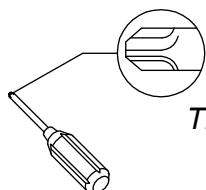
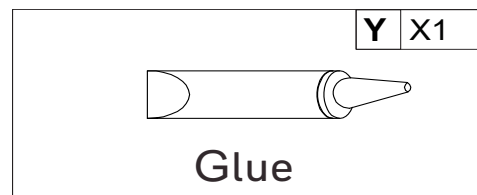
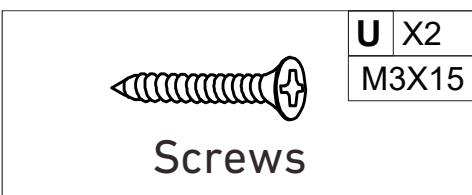
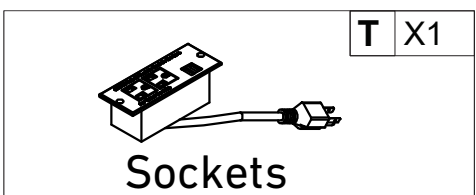
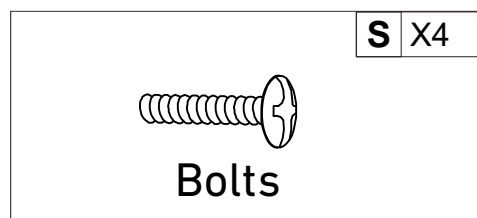
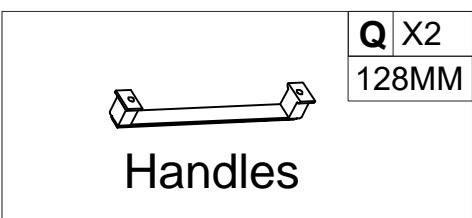
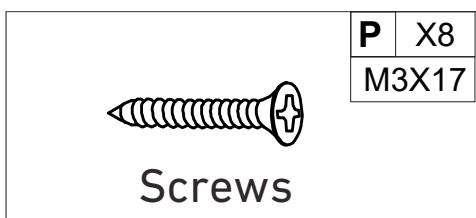
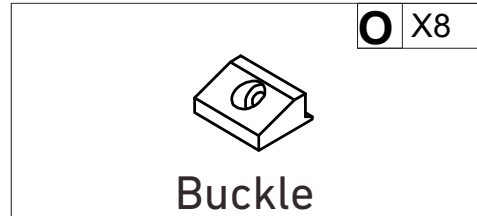
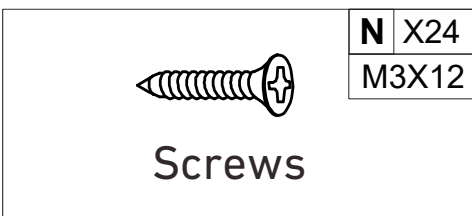
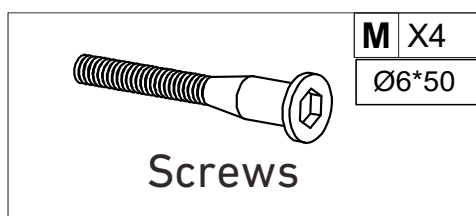
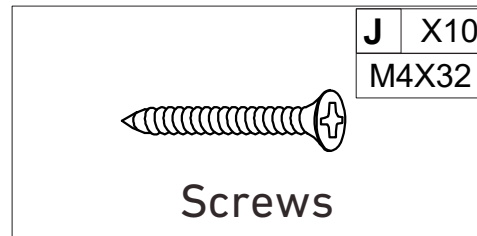
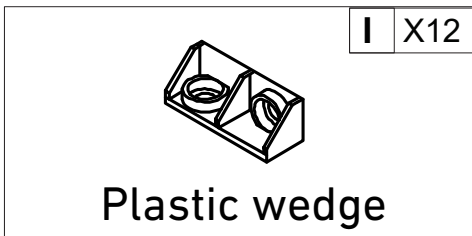
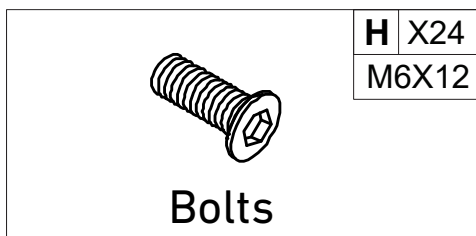
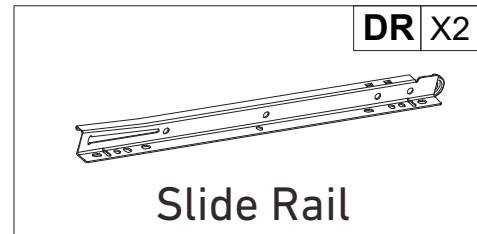
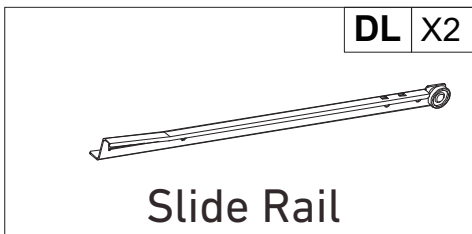
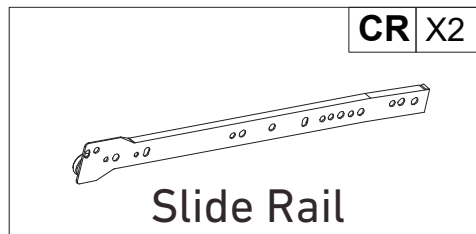
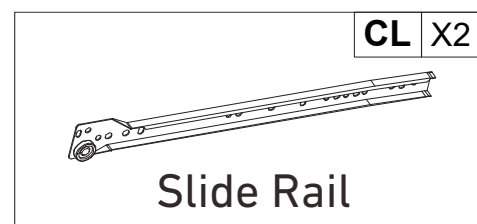
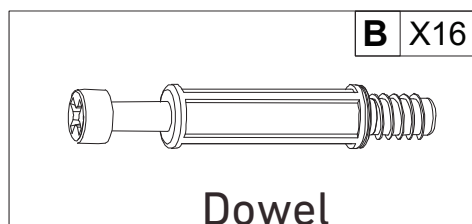
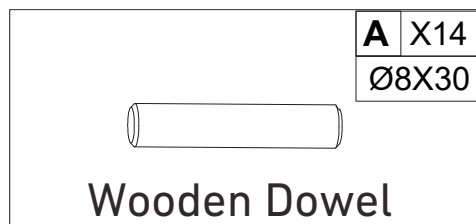

Philips head screwdriver required for assembly
(not included)

*The hardware quantities listed above are required for proper assembly.
Some extra hardware may also have been included.*

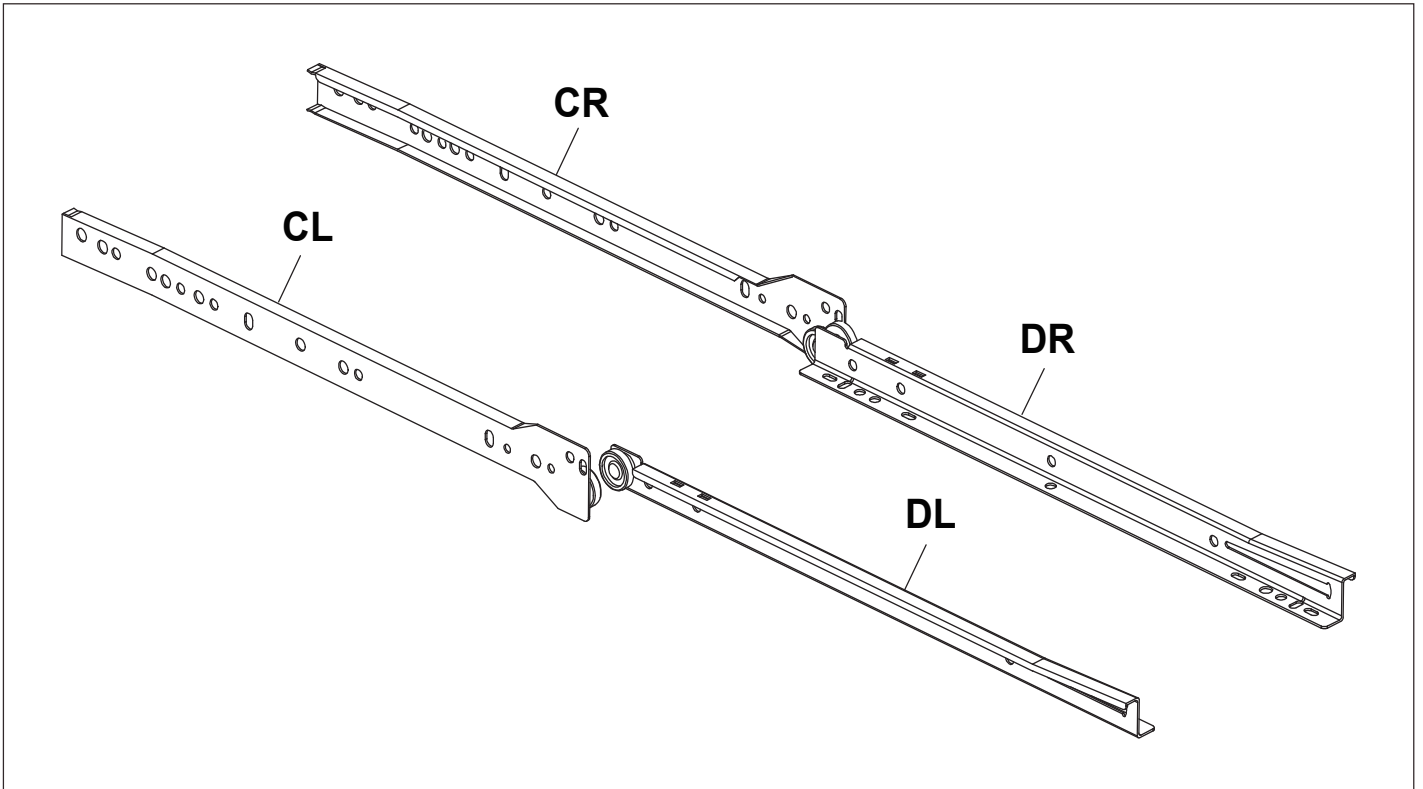

Minifix Position

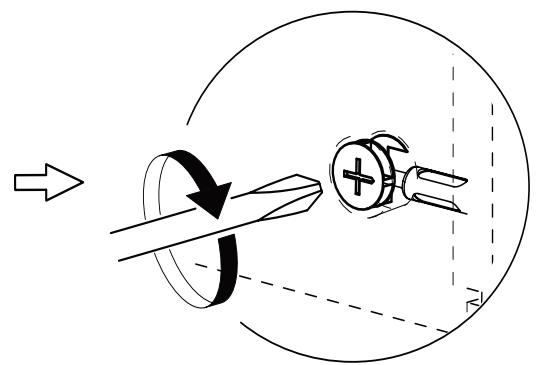
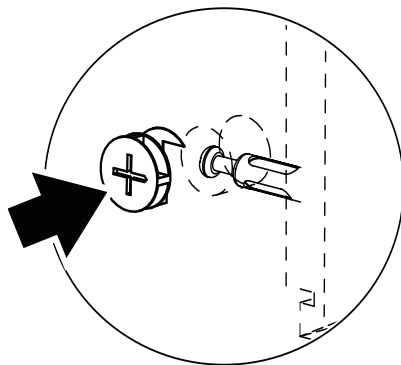
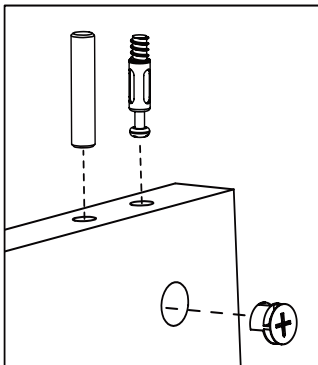

TIPS:

As shown, make sure each part is in the correct position.

Make sure the gap of the Eccentric Wheel is aligned with the Dowel, and then tighten it completely.

Step 1

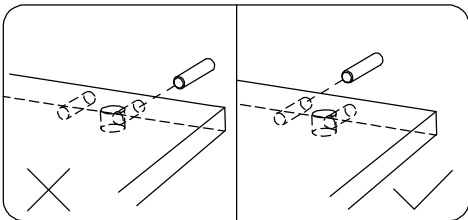
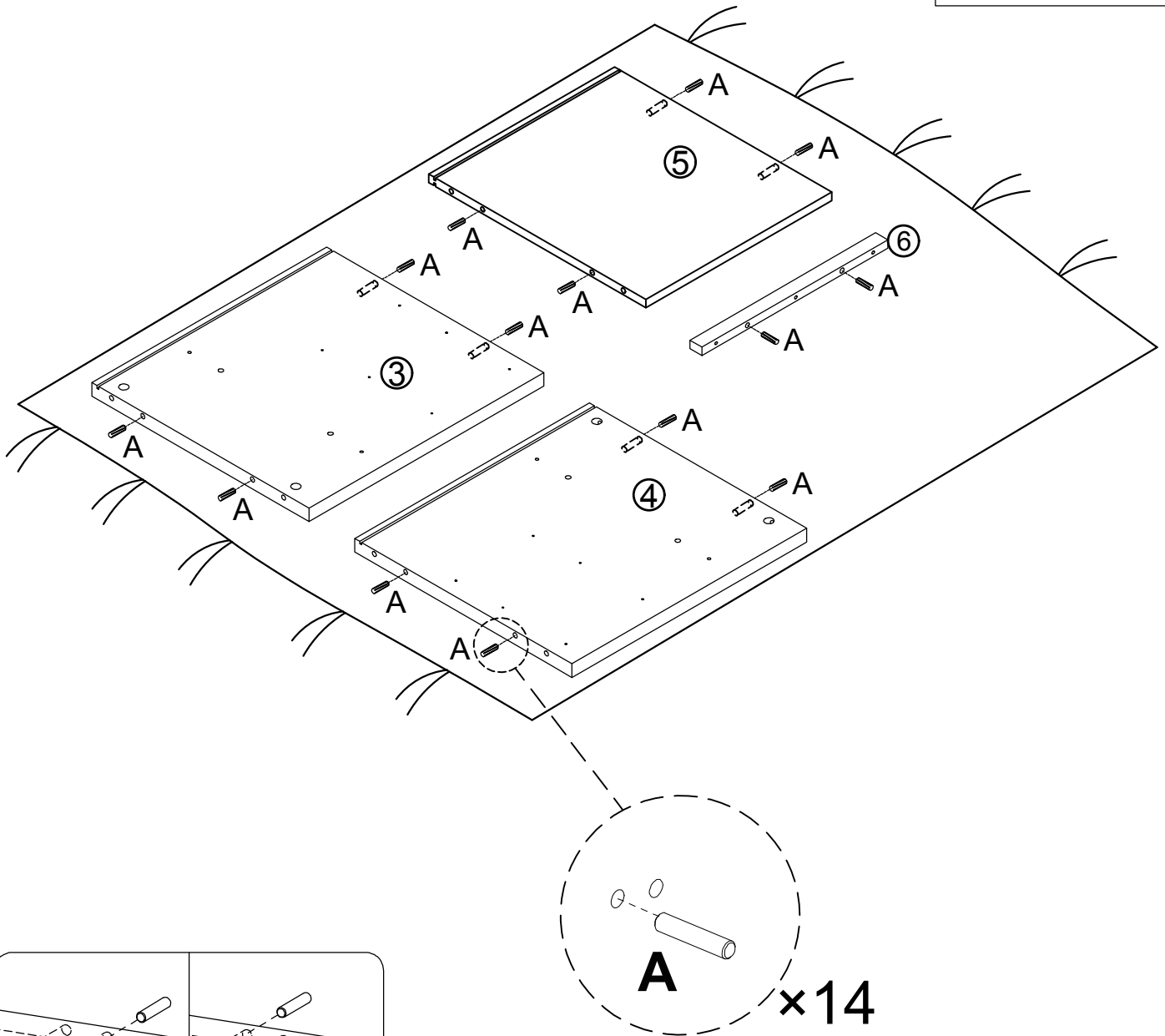
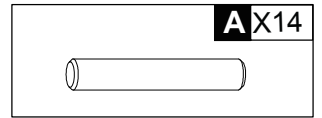

Attach Wooden Dowel (A)*14 to the Boards (3, 4, 5 & 6) as shown

Note:

1. Put a blanket under the Board to avoid scratch or damage.
2. Make sure the Wooden Dowel is installed in the correct position.

Step 2

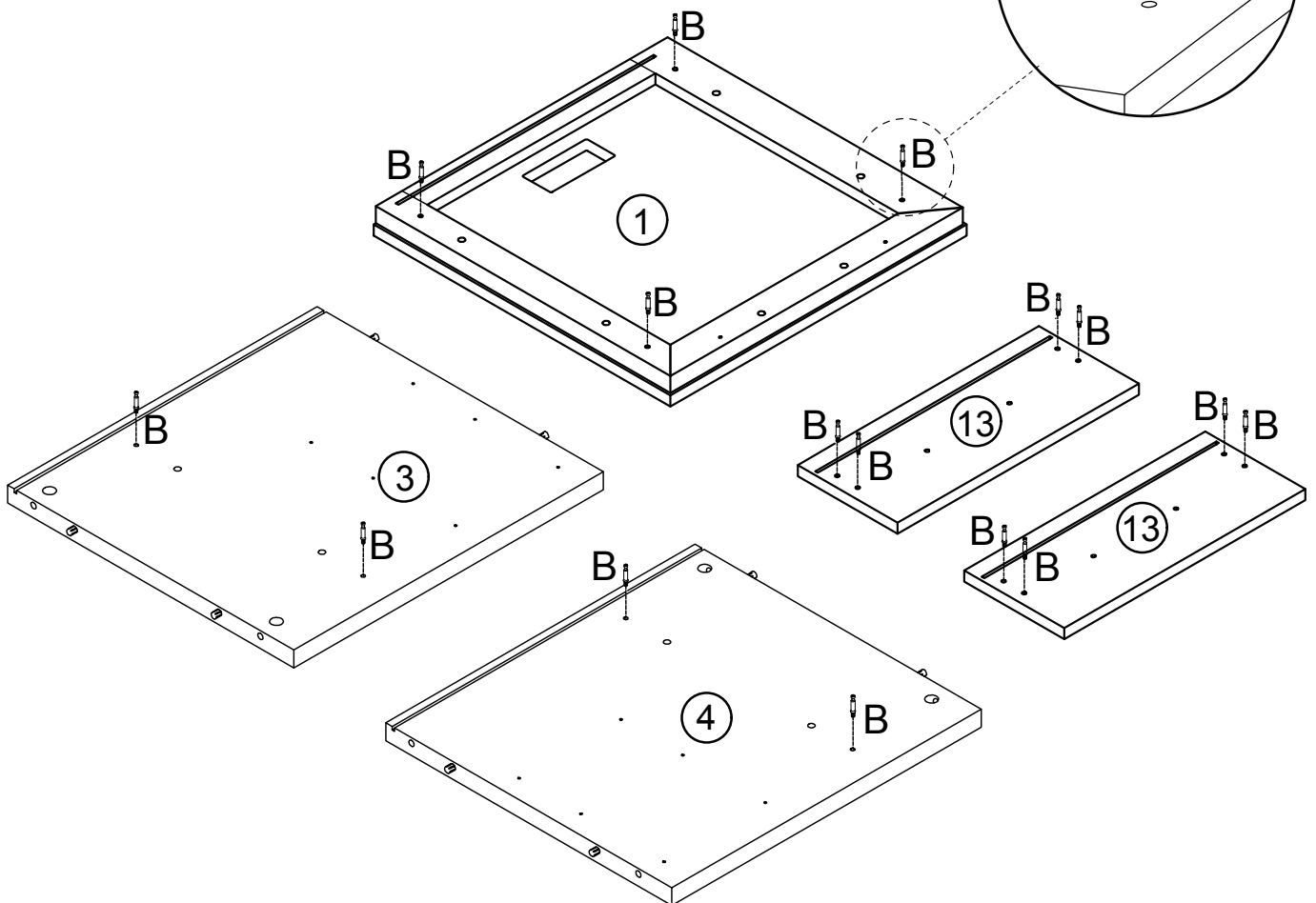
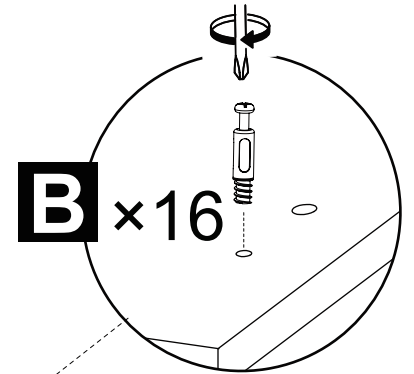
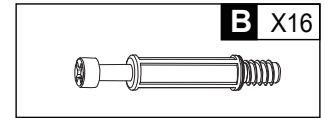
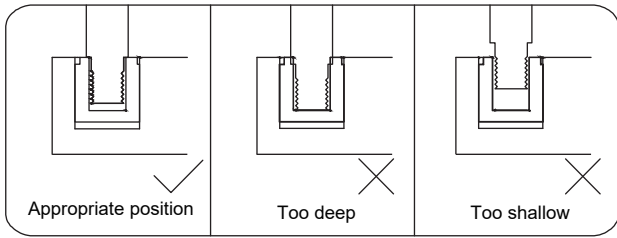

Fix Dowel (**B**)*16 to the Board (**1, 3, 4 & 13*2**)

Note:

Please do not screw Dowel too deep or too shallow.

Step 3

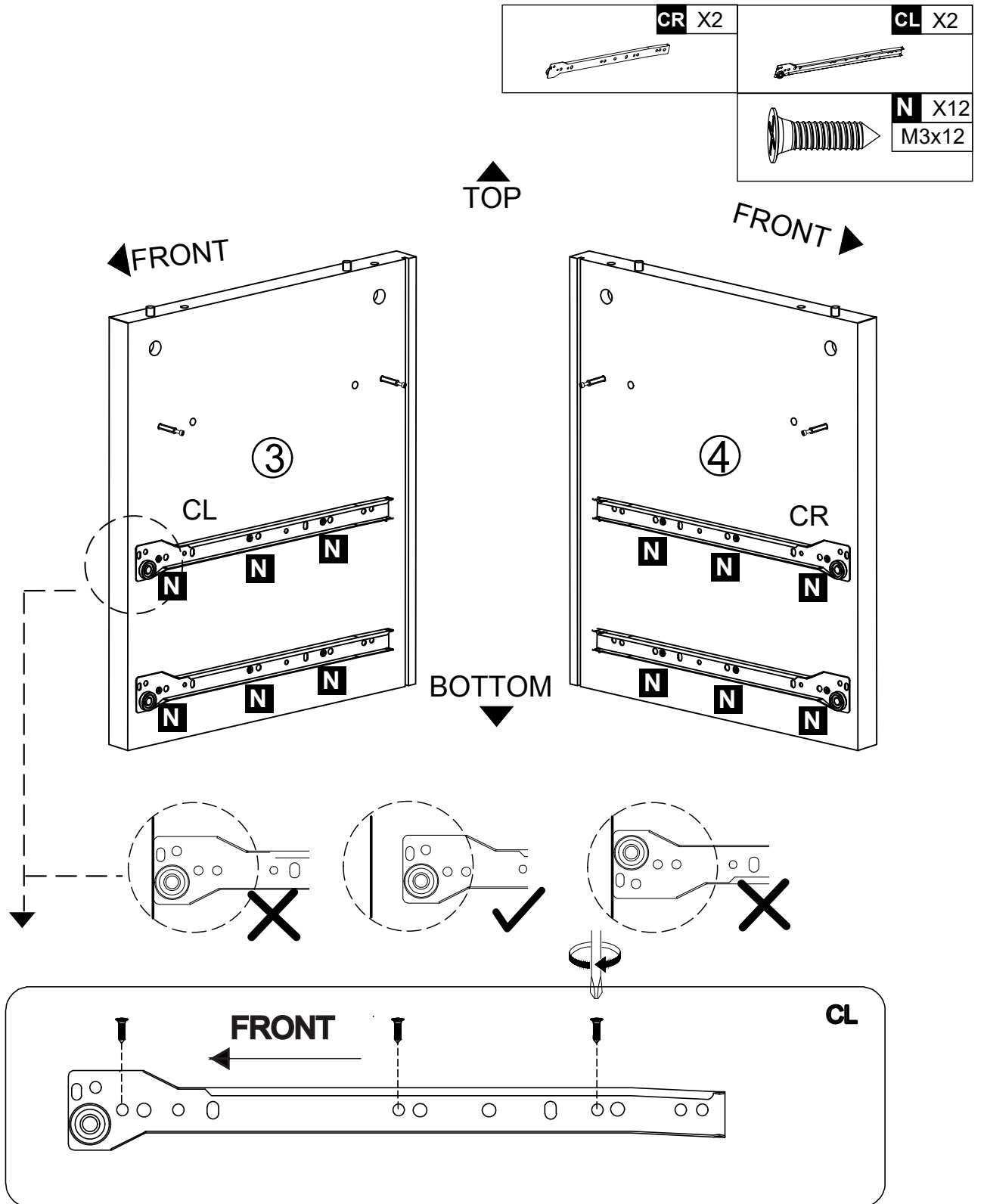

Attach Slide Rail (**CL**)*2 to the Board (**3**), and Slide Rail (**CR**)*2 to the Board (**4**) with Screws (**N**)*12

Note:

1. As shown, make sure the Board and Slide Rail are oriented correctly.
2. When installing, please make sure the Screws are flattened, not crooked. Otherwise the drawers will not be installed perfectly.

Step 4

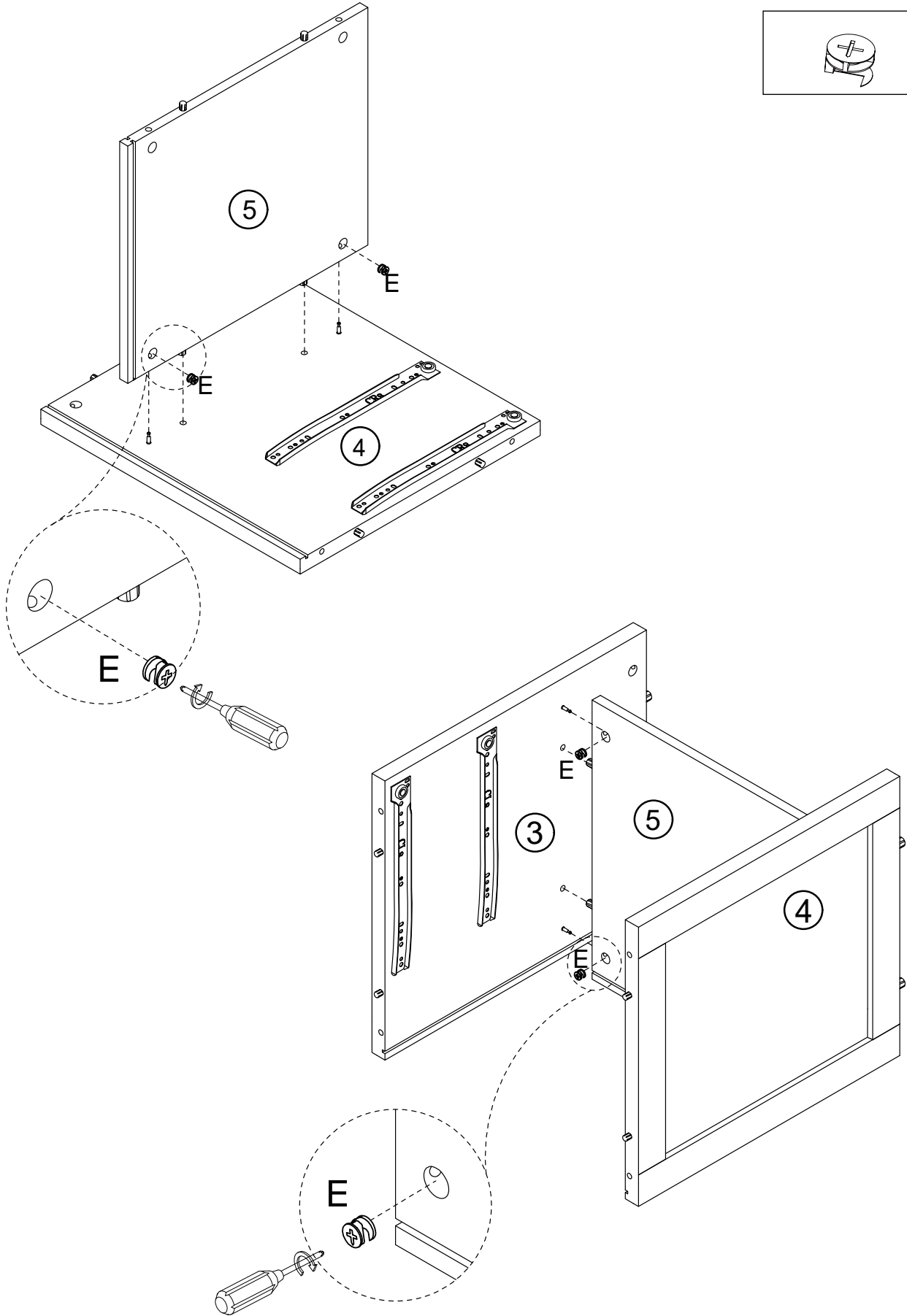

Fix Board **(3&4)** to both sides of the Board **(5)** with Eccentric Wheel **(E)*4**.

Step 5

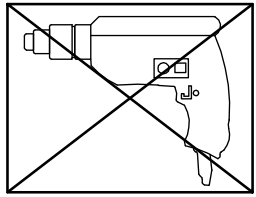
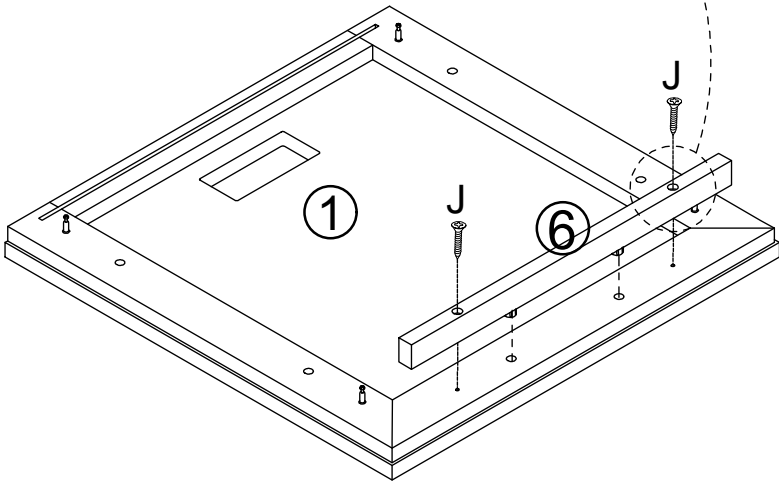
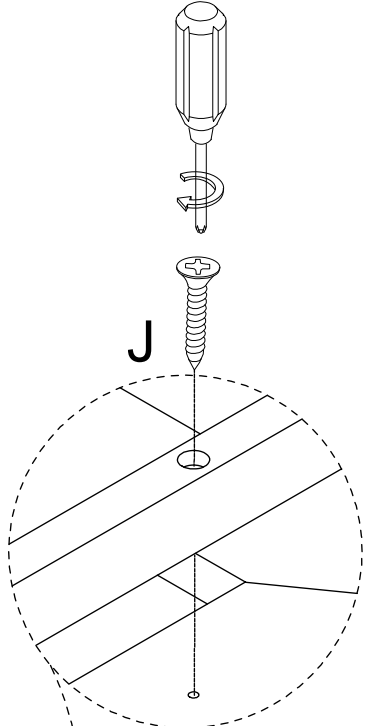
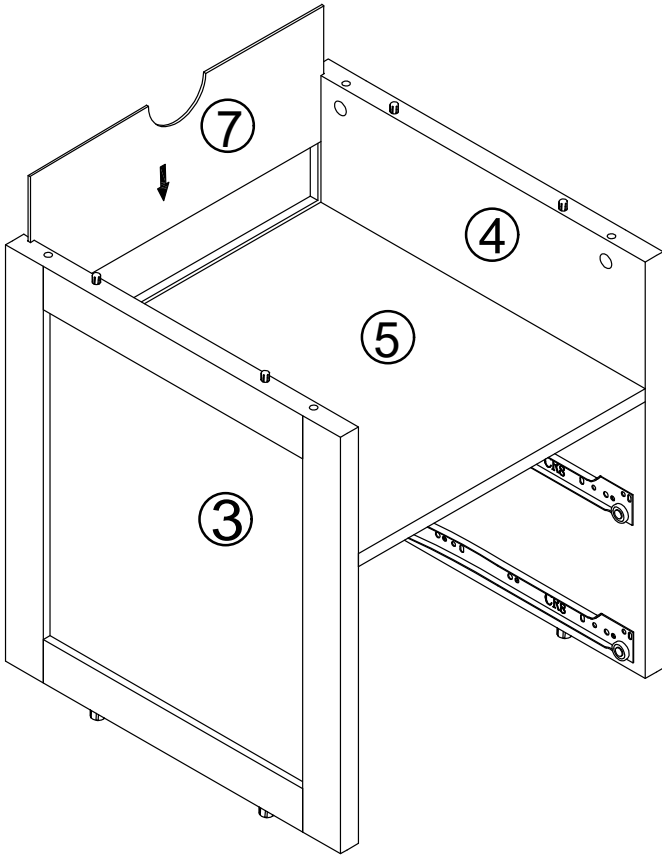
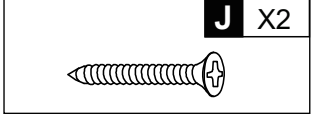

Insert the Board (7) into the grooves of the Boards (3&4)
Attach Board (6) to the Boards (1) with Screws (J)*2.

Step 6

	E X4
---	-------------

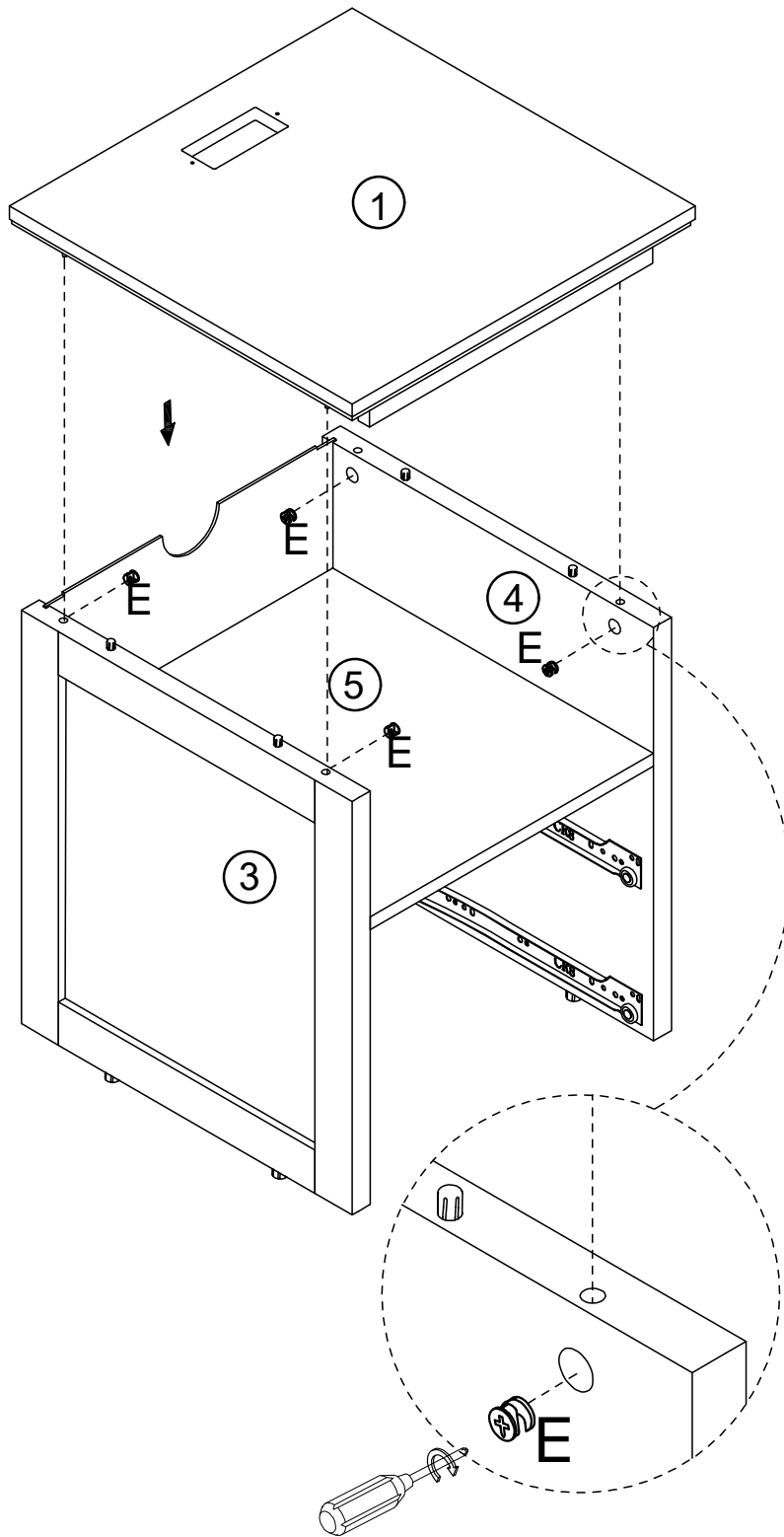

Fix Board **(3&4)** to the Board **(1)** with Eccentric Wheel **(E)*4**.

Step 7

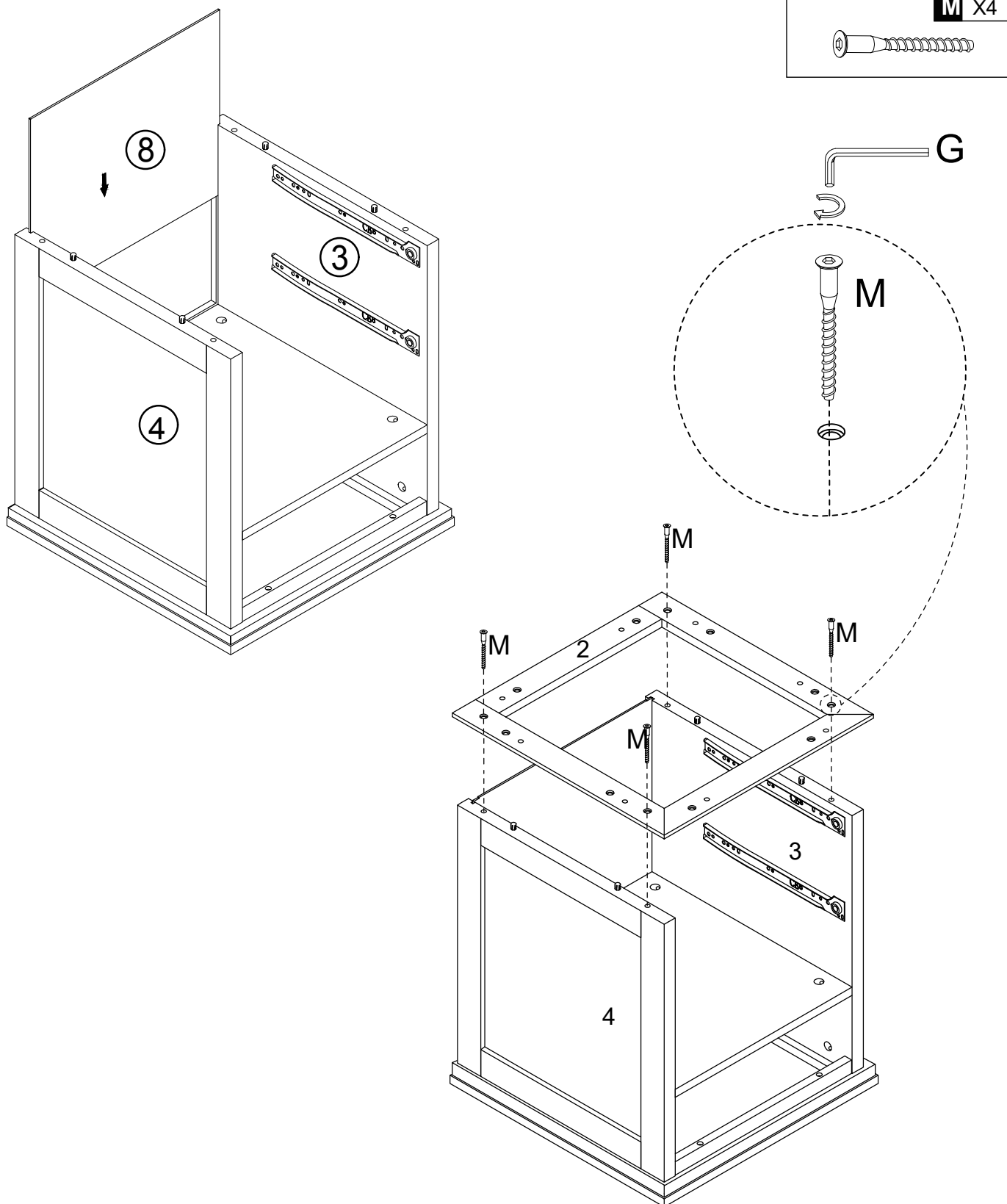

Turn the installed Cabinet over

Insert the Board **(8)** into the grooves of the Boards **(3&4)**

Attach Board **(2)** to the Bottom side of the Boards **(3&4)** with Screws **(M)*4**

Step 8

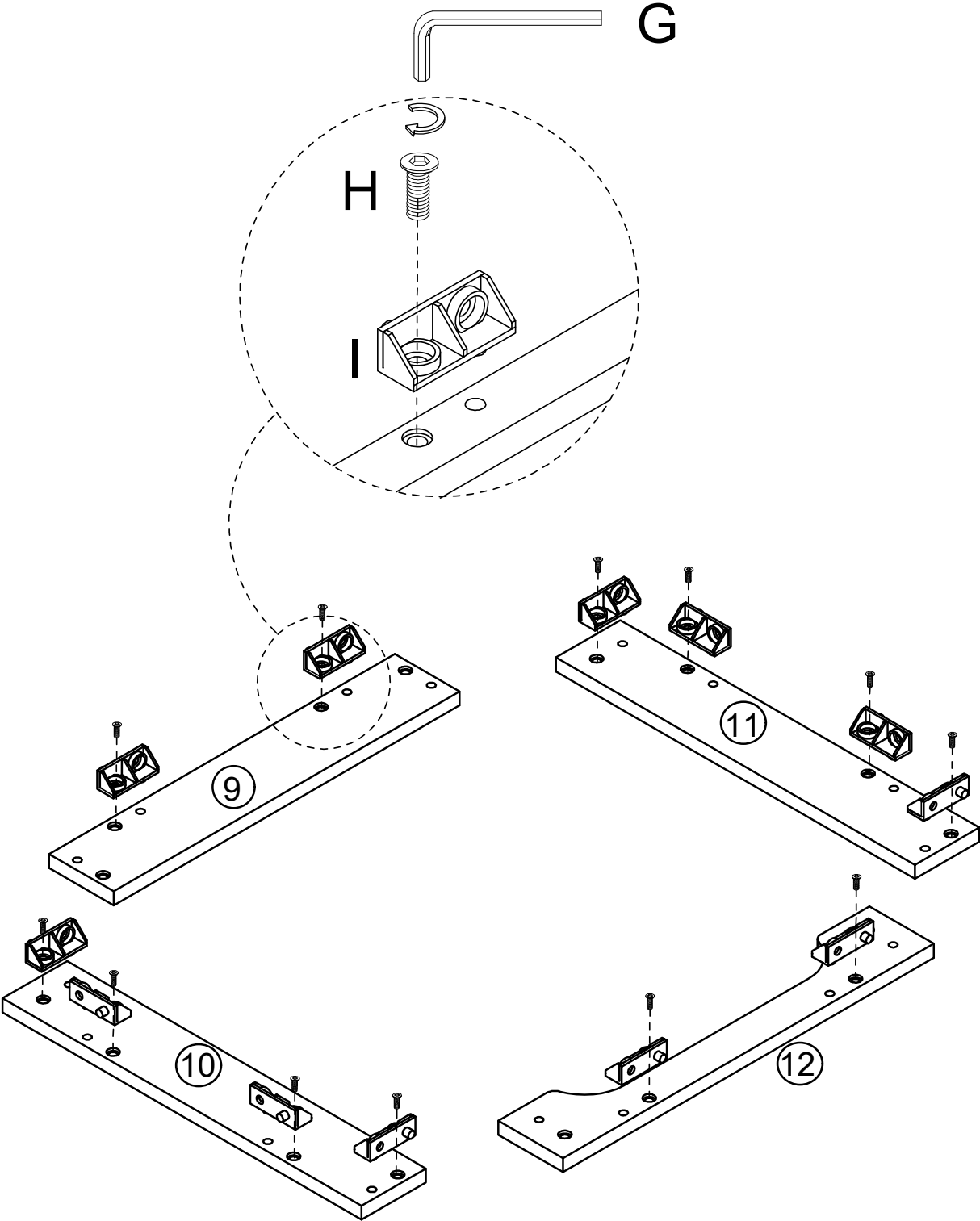
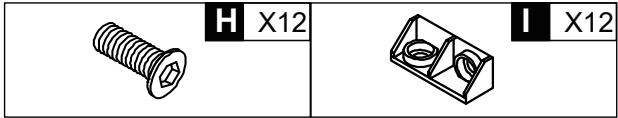

Attach Plastic wedge **(I)***12 to the Board **(9,10,11&12)** with Bolts **(H)***12 as shown

Step 9

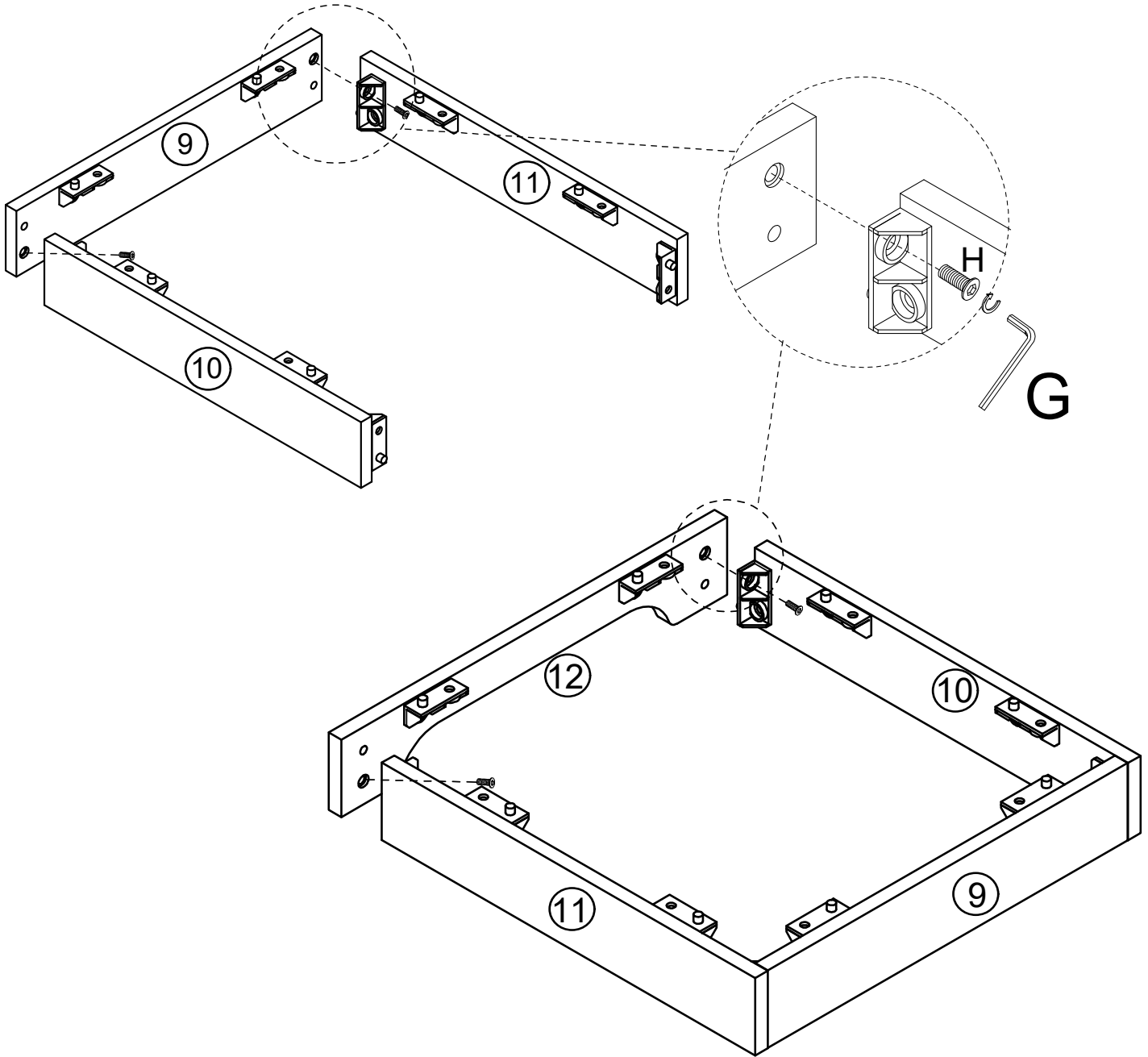
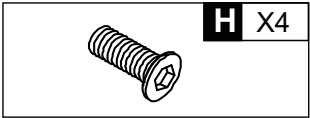

Step 10

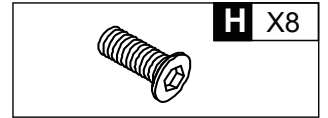
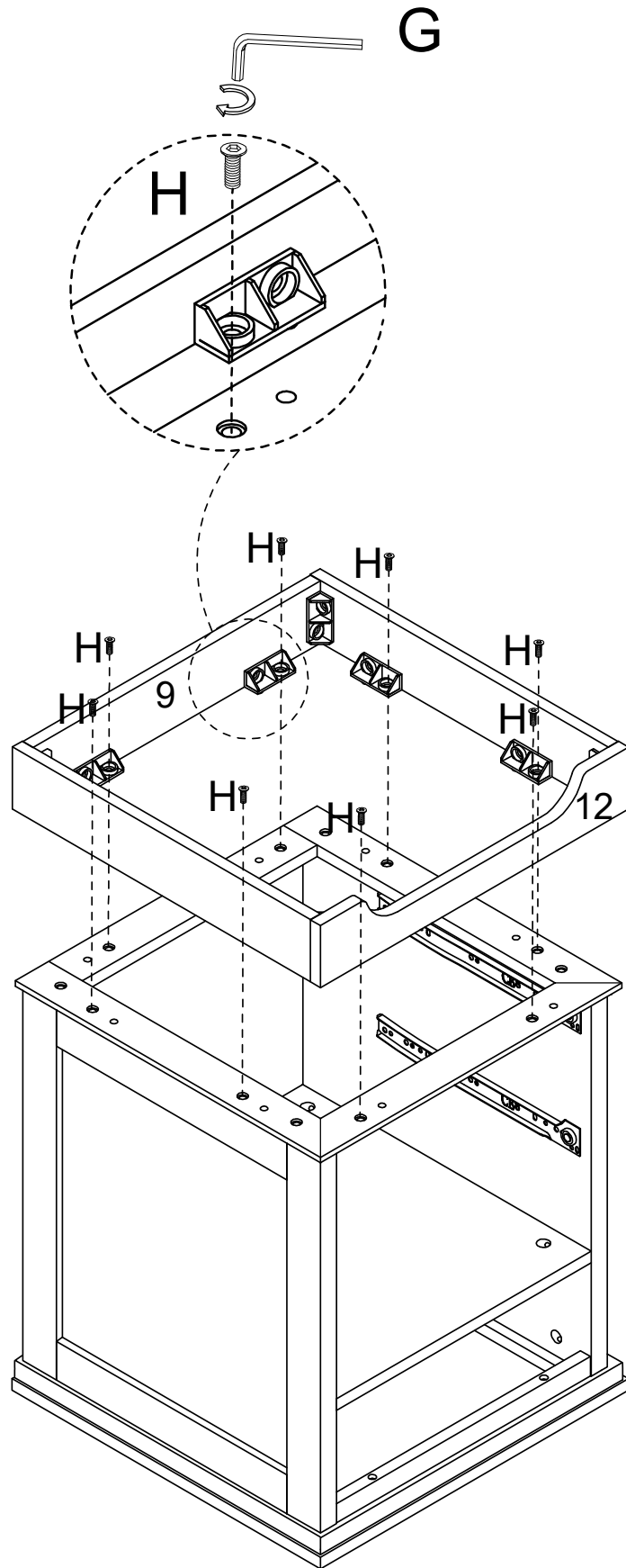

Step 11

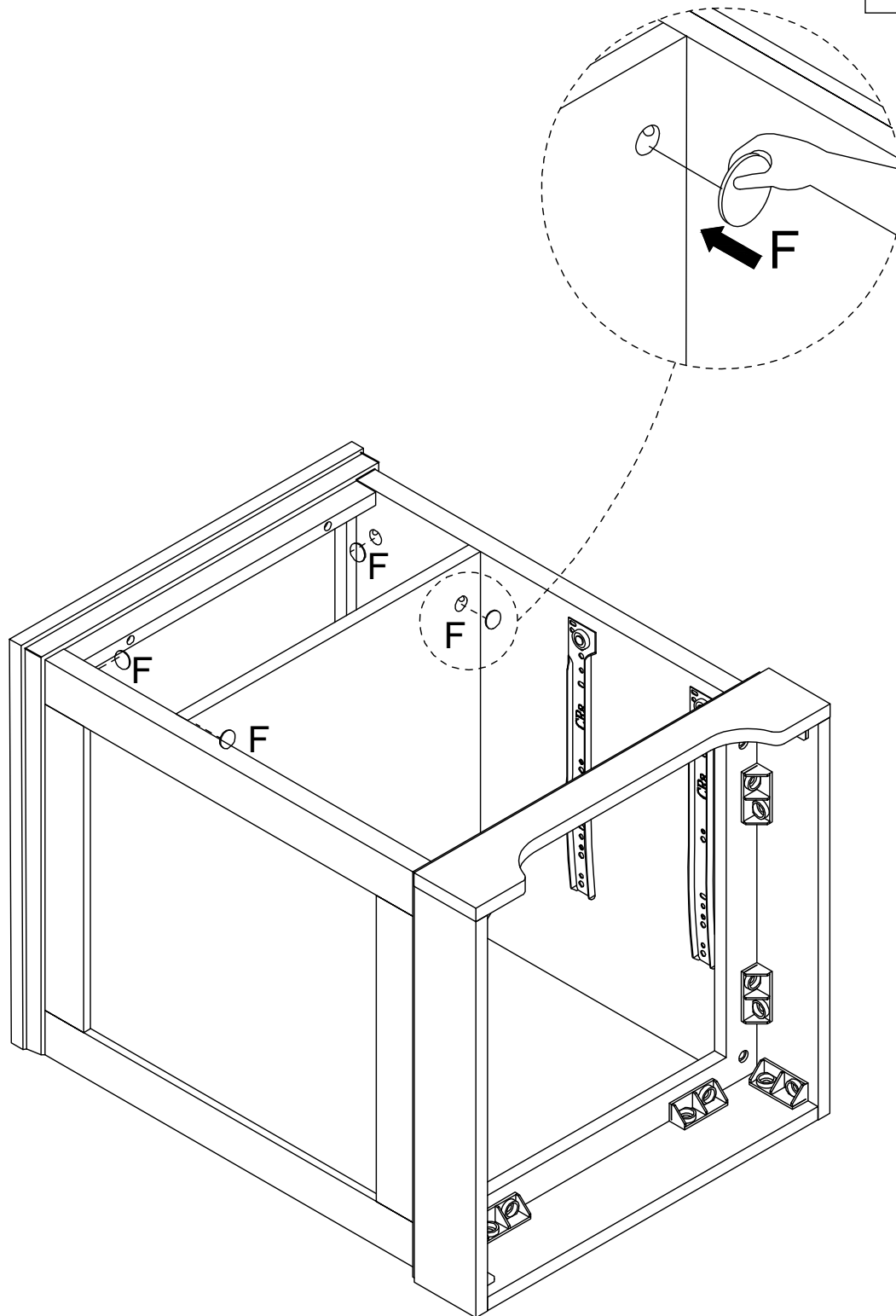

Using Cover-up Sticker(**F**)***8** to cover the exposed part of Screws.

Step 12

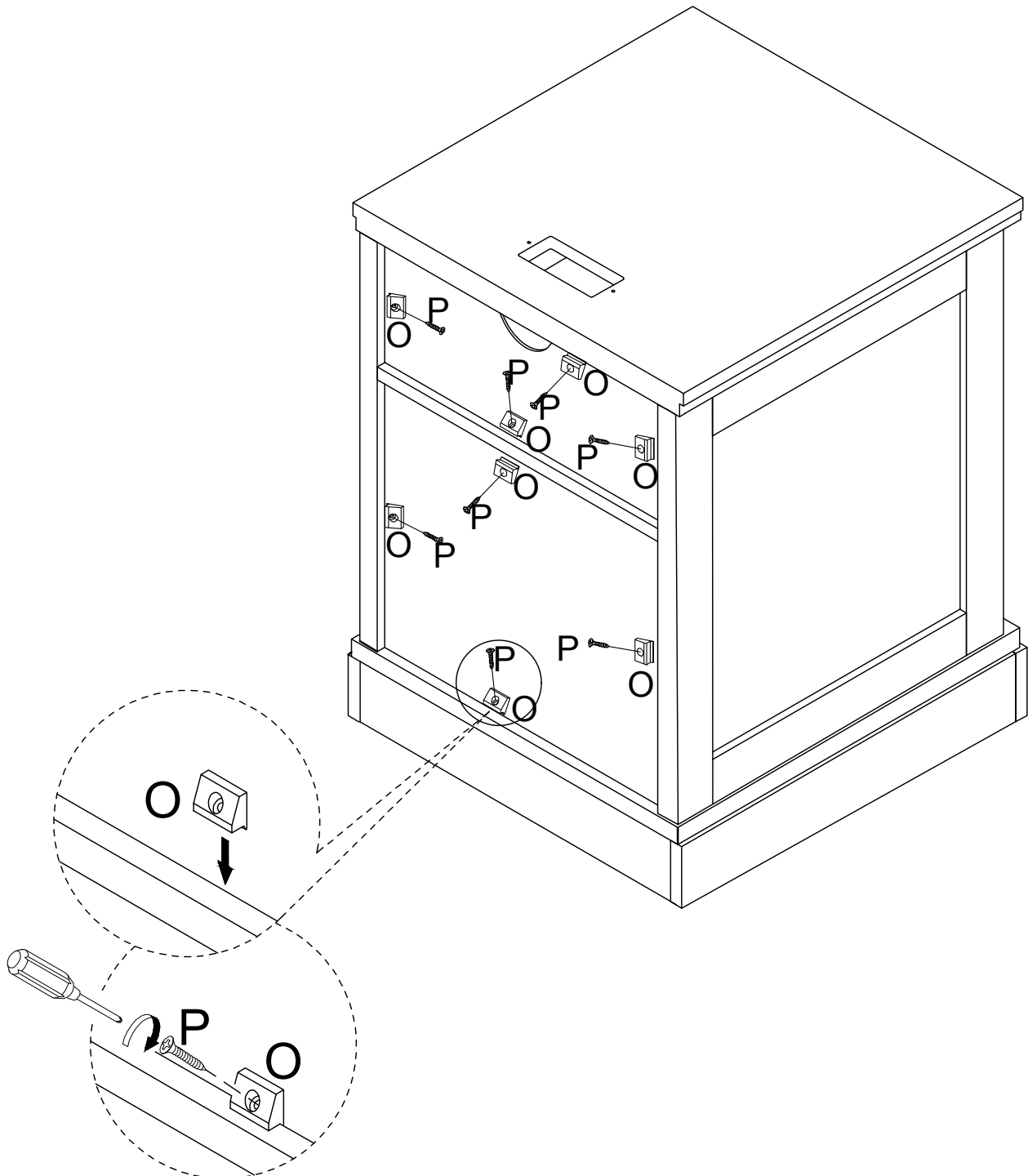
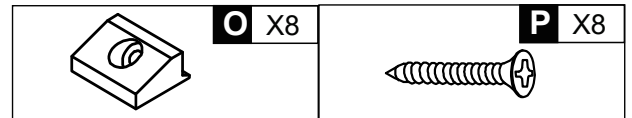

As shown, fix Buckle **(O)*8** on the back of the installed Cabinet with Screws **(P)*8**.

Step 13

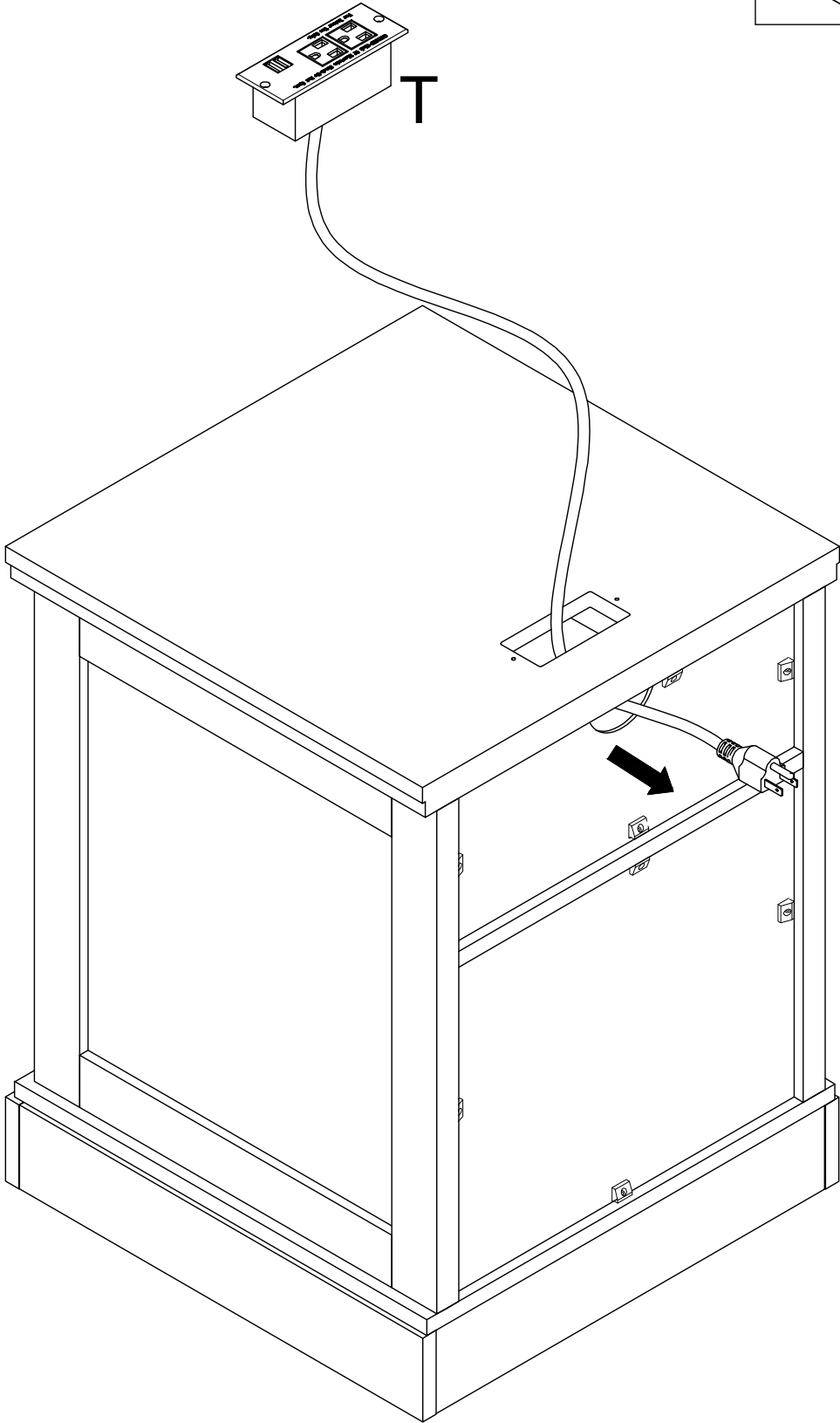
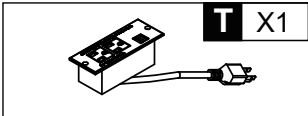

Step 14

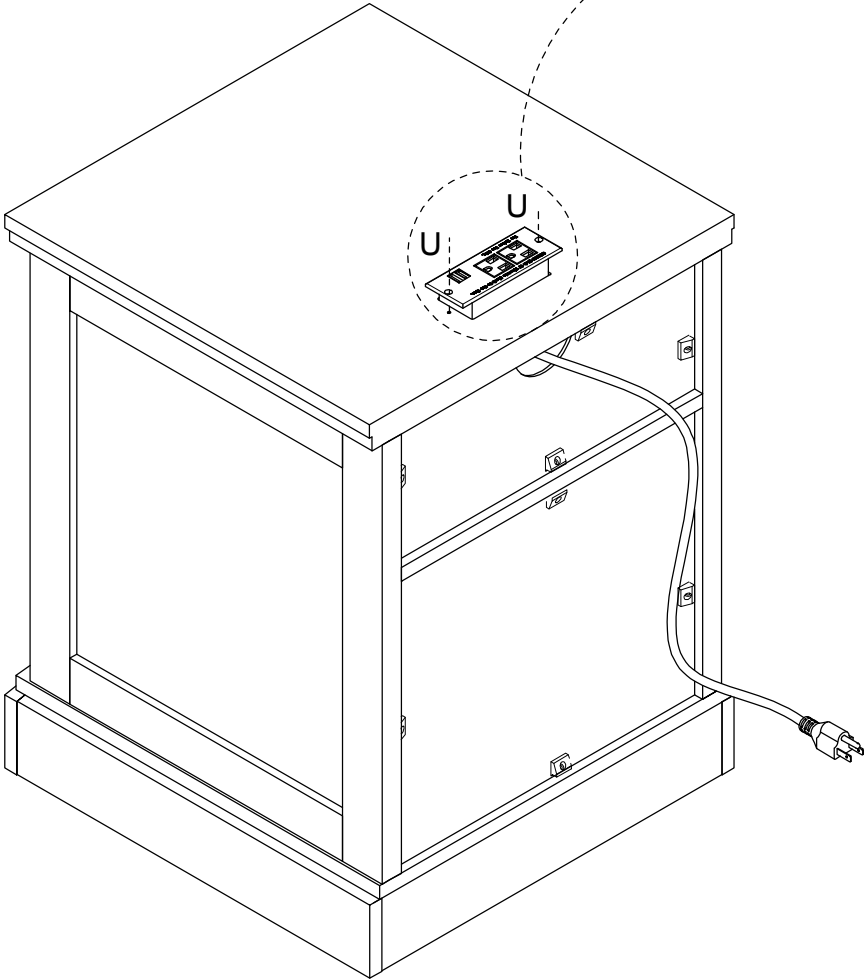
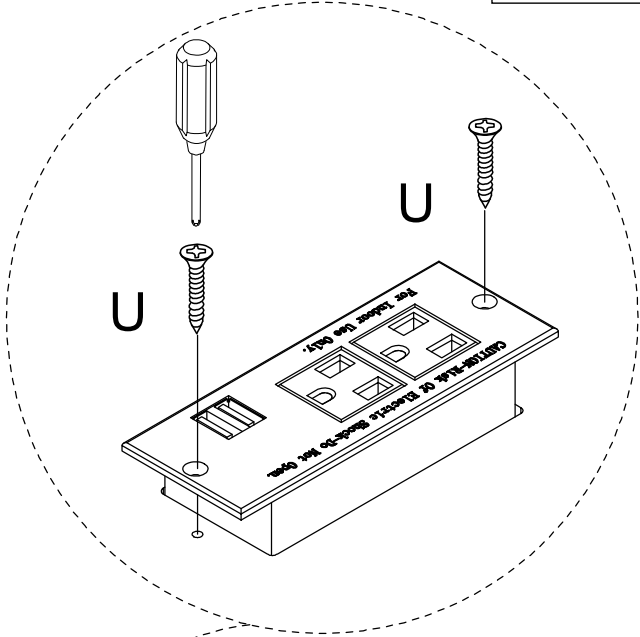
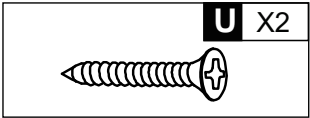

Step 16

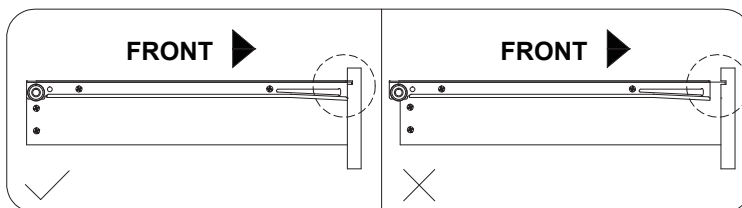
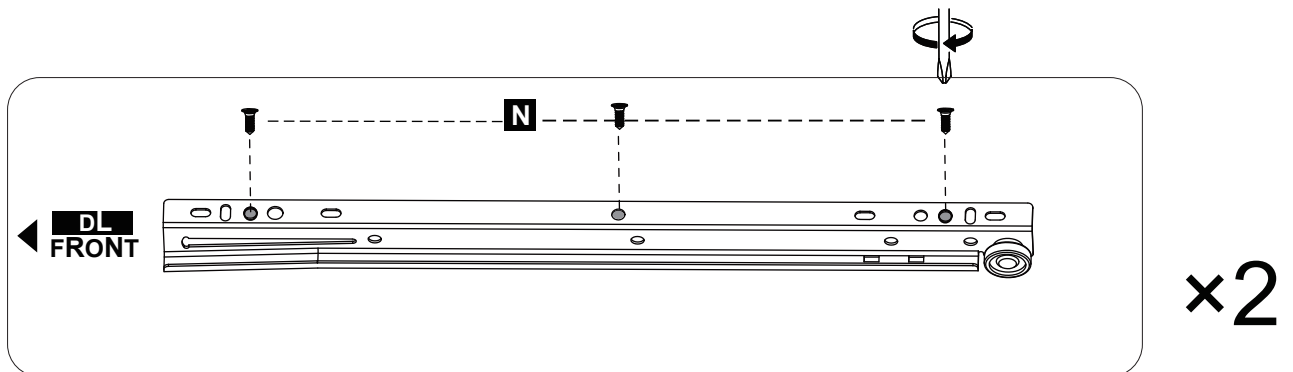
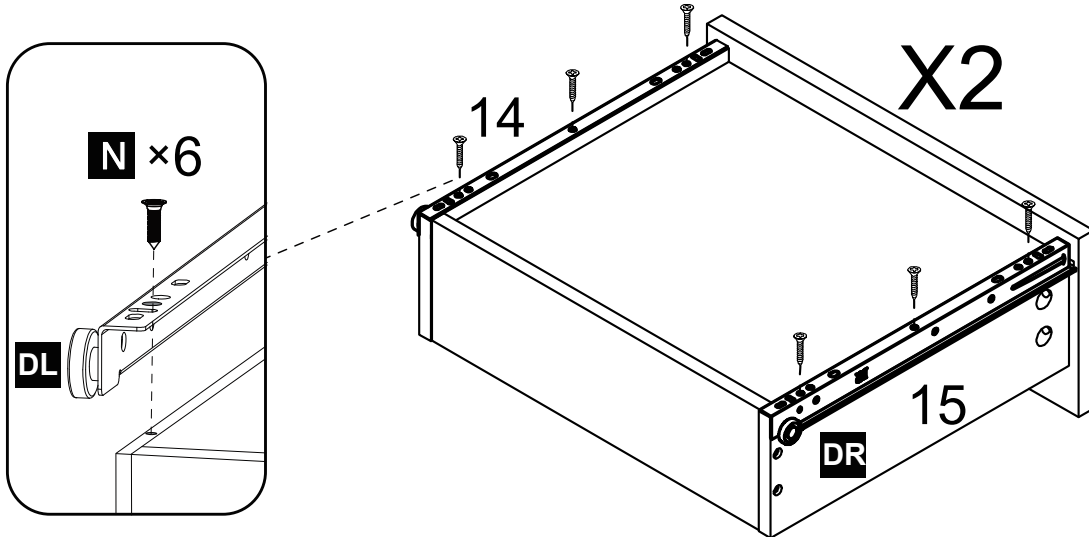
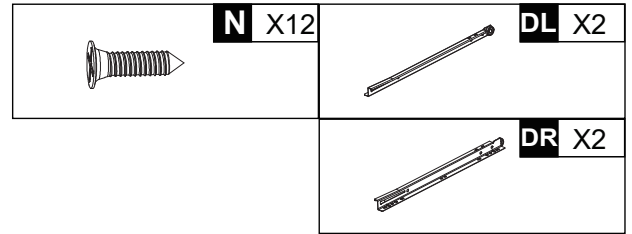
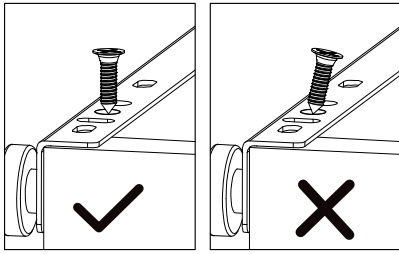



Turn the installed Drawer over. Attach Slide Rails (**DL&DR**) to the Boards (**14&15**) on each side of the drawer with Screws (**N**)*12

Note:

1. According to the "**FRONT**" of the Drawer, distinguish the left and right side of the Slide Rail.
2. Install the Slide Rail against the Board (**14&15**)

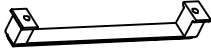
Step 17

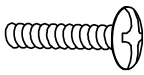
 Q X2	 F X8
	 S X4

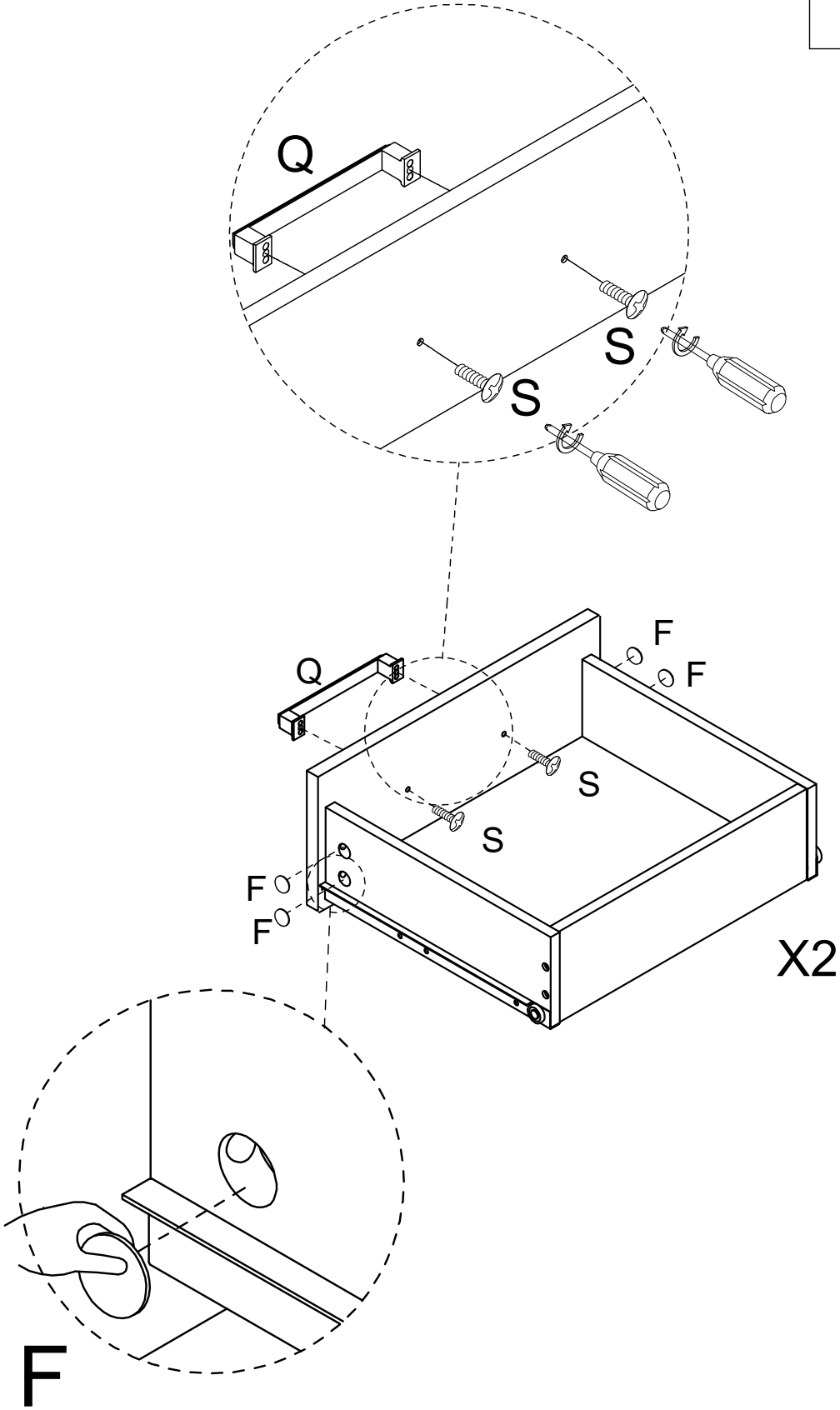

Step 18

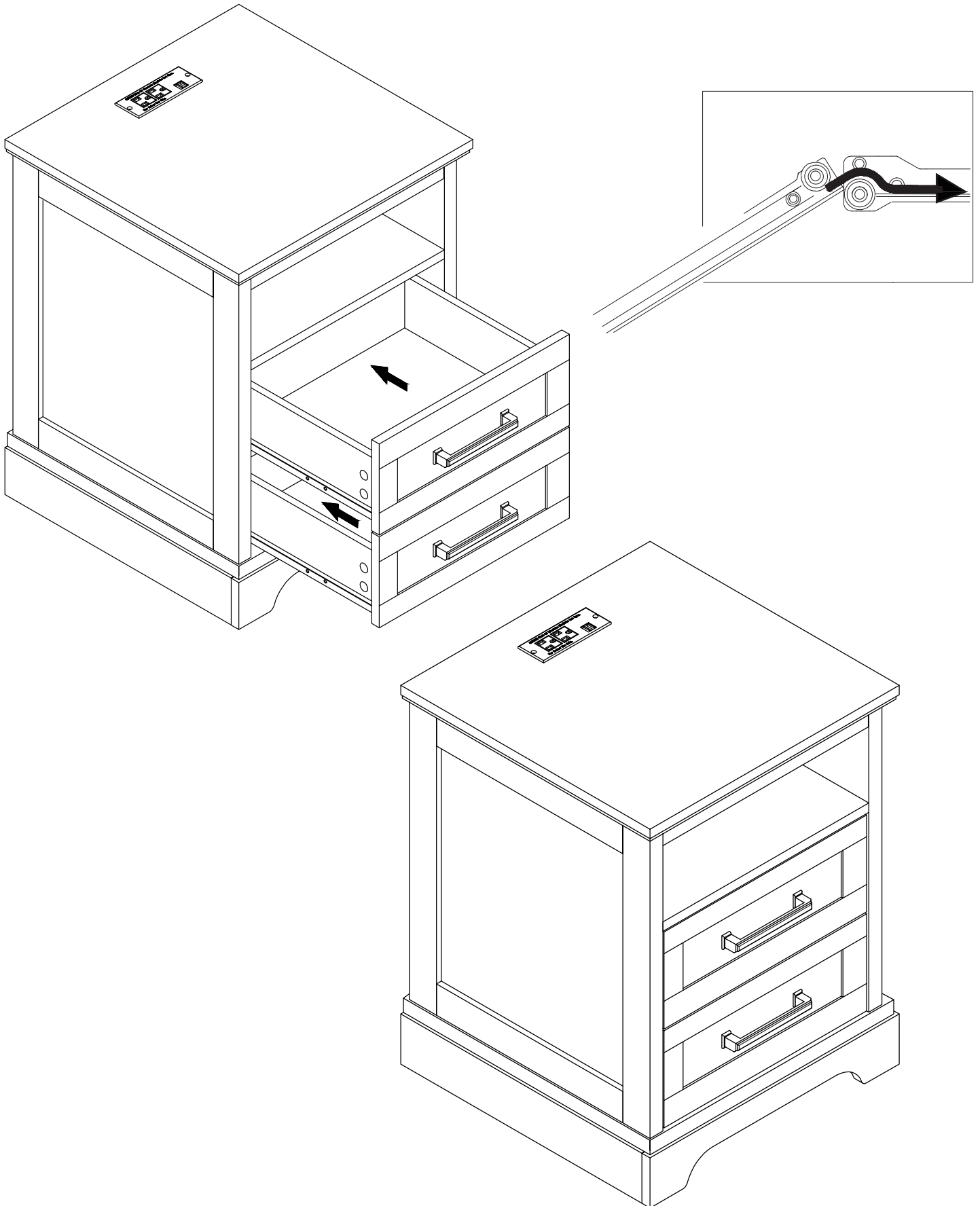

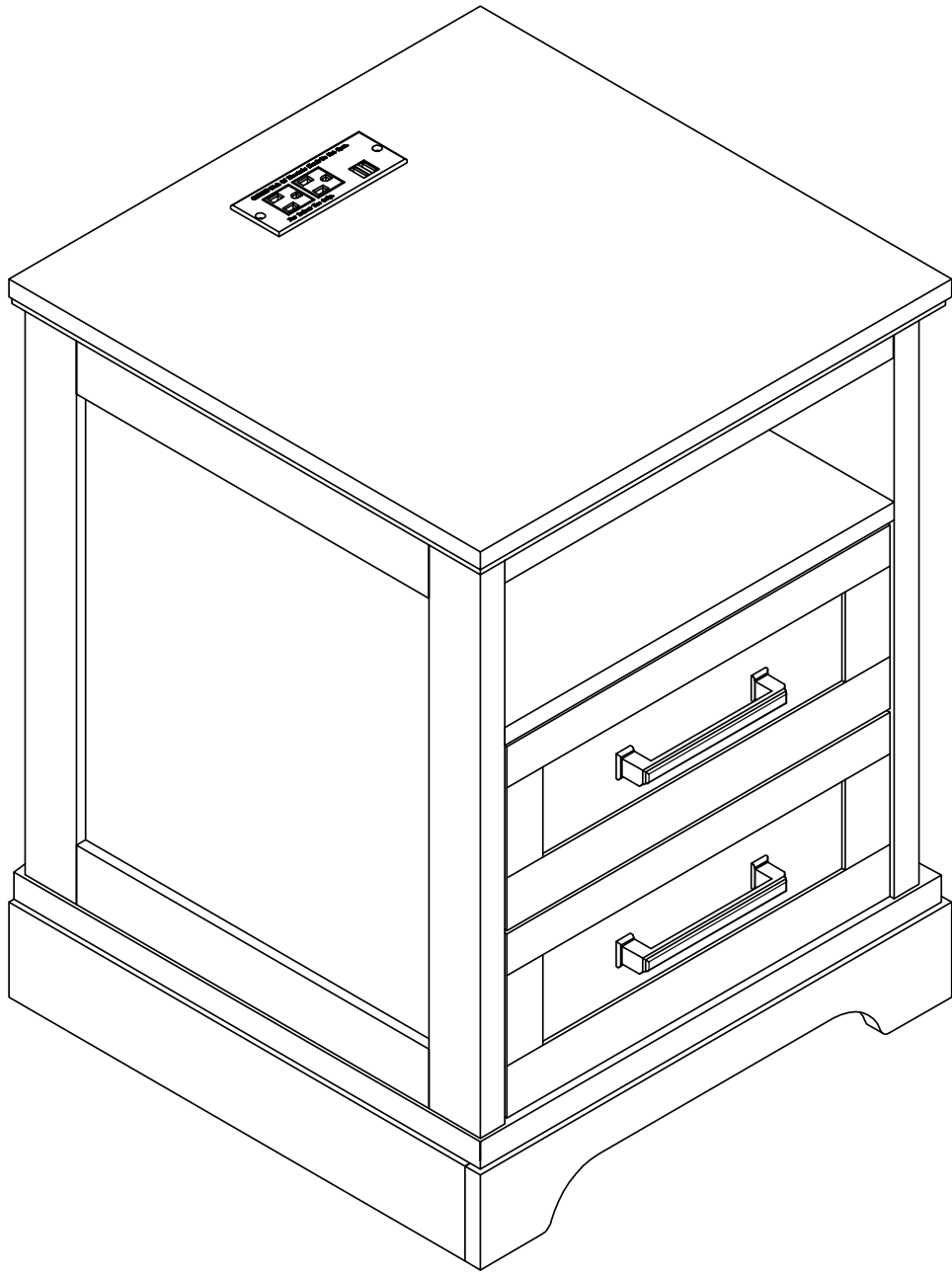

Thank you for choosing this product. We strive to provide you with the best quality products and service in the industry. Should you have any issues, please don't hesitate to contact us.