

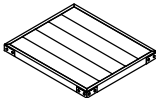

ASSEMBLY INSTRUCTIONS

END TABLE

**NOTE: THIS ITEM NOT RECOMMENDED FOR COMMERCIAL USE
KEEP THIS DOCUMENT FOR REFERENCE IN CASE PARTS ARE NEEDED
DO NOT TIGHTEN SCREWS UNTIL COMPLETELY ASSEMBLED !!**

PART LISTS

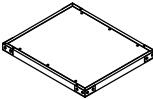
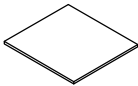
No	DESCRIPTION	Q'TY
A	TABLE TOP 	1PC
B	SIDE PANEL 	2PCS
C	BOTTOM PANEL 	1PC
D	ADJUSTABLE SHELF 	1PC

HARDWARE LISTS

No	DESCRIPTION	Q'TY
1	 SHORT BOLT $\text{Ø}1/4" \times 3/4"$	16PCS
2	 LONG BOLT $\text{Ø}1/4" \times 1-1/4"$	12PCS
3	 LOCK WASHER $\text{Ø}1/4" \times 10D \times 1.1\text{mm}$	28PCS
4	 FLAT WASHER $\text{Ø}1/4" \times 19D \times 2\text{mm}$	28PCS
5	 ALLEN KEY $2-1/4" \times 4\text{mm}$	1PC
6	 METAL CASTERS $\text{Ø}3" \times 59 \times 92\text{mm}$	2PCS
7	 LOCKING METAL CASTERS $\text{Ø}3" \times 59 \times 92\text{mm}$	2PCS
8	 WOOD DOWEL $\text{Ø}8 \times 30\text{mm}$	8PCS
9	 SHELF PIN $\text{Ø}30 \times 18 \times 14\text{mm}$	4PCS
10	 SCREWS $\text{Ø}6 \times 12\text{mm}$	4PCS

STEP 1

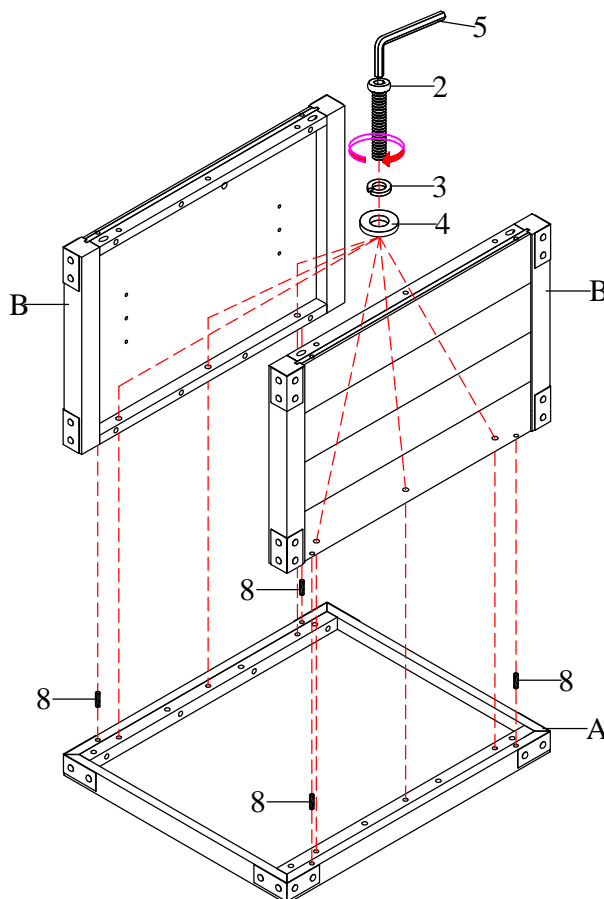

ASSEMBLY INSTRUCTIONS

END TABLE

**NOTE: THIS ITEM NOT RECOMMENDED FOR COMMERCIAL USE
KEEP THIS DOCUMENT FOR REFERENCE IN CASE PARTS ARE NEEDED
DO NOT TIGHTEN SCREWS UNTIL COMPLETELY ASSEMBLED !!**

STEP 2

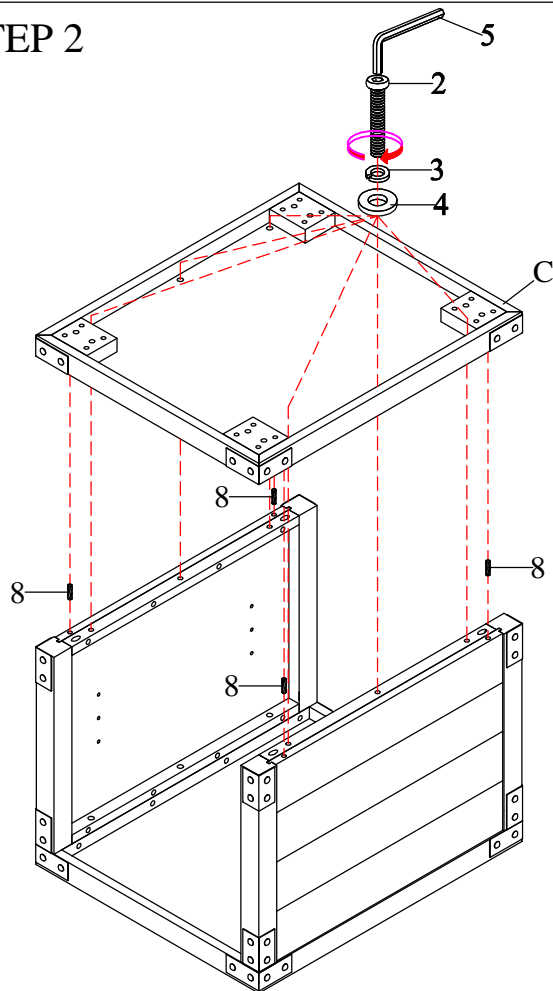

STEP 3

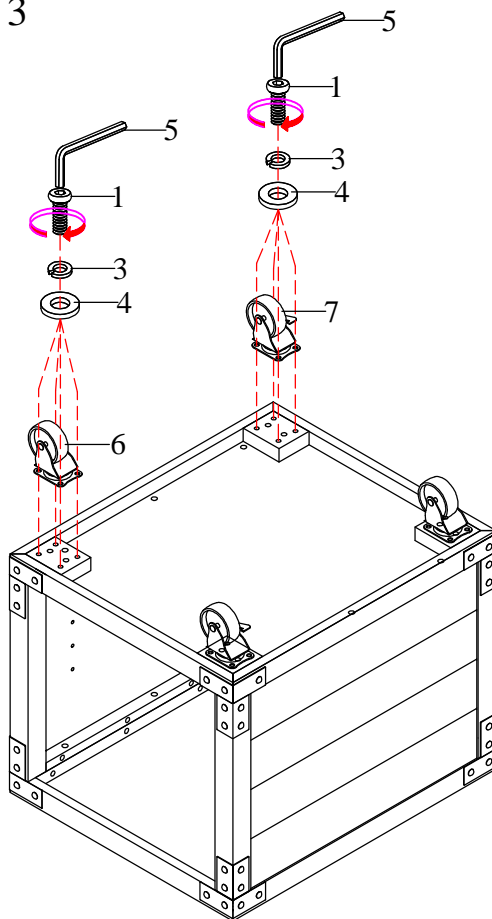

STEP 4

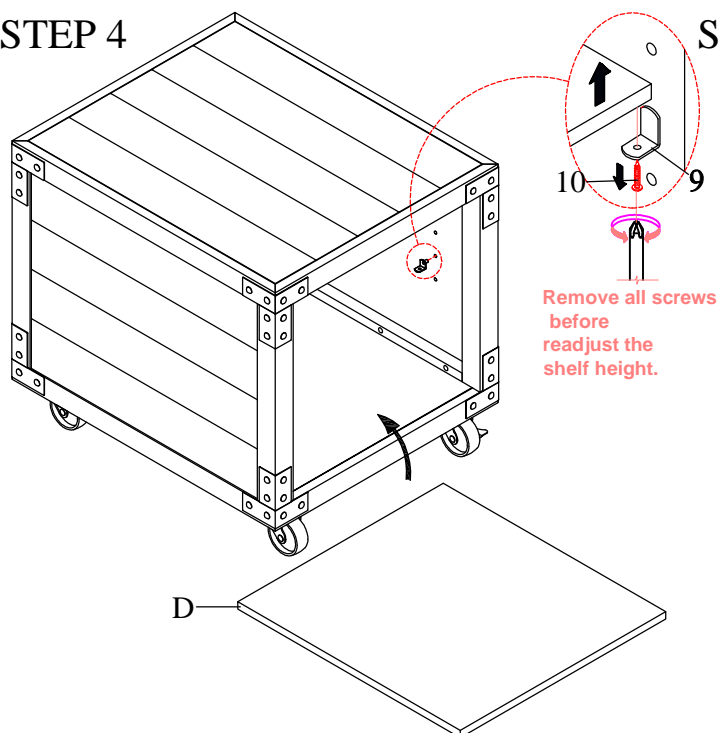

STEP 5

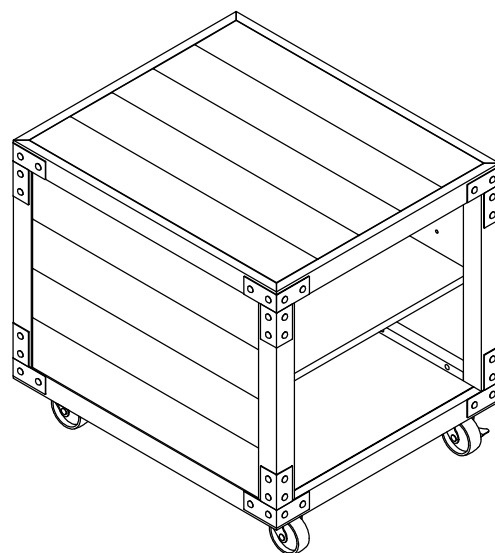

Remove all screws
before
readjust the
shelf height.