

ASSEMBLY INSTRUCTION

Thank you for purchasing this quality product. Be sure to check all packing material carefully for small parts which may have come loose inside the carton during shipment. Separate, identify and count all parts and hardware. Compare with the parts list to be sure all parts are present.

IMPORTANT : PLEASE READ INSTRUCTION BEFORE STARTING THE ASSEMBLY.

"DO NOT TIGHTEN SCREWS UNTIL COMPLETELY ASSEMBLED"

"DO NOT OVERTIGHT ANY HARDWARE"

WARNING : SMALL PARTS AND HARDWARE NOT FOR CHILDREN UNDER 3 YEARS. ADULT ASSEMBLY REQUIRED.

TABLE OF CONTENTS

HARDWARE LIST	PAGE 2
PARTS LIST	PAGE 3
PARTS' LOCATION	PAGE 4
ASSEMBLY STEPS	PAGE 5 - 6
ASSEMBLY COMPLETED	PAGE 6

ASSEMBLY TOOLS REQUIRED

1. Screwdriver (not provide)

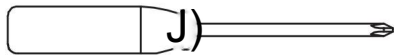

2. Hammer (not provide)





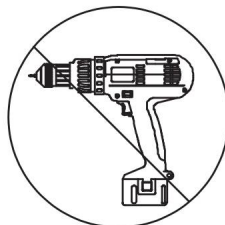



Skip the power drill this time.

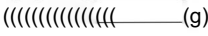

ASSEMBLY INSTRUCTION

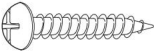
HARDWARE LIST

ITEM	DESCRIPTION	DRAWING	QTY
A	JCBC SCREW M6 x 50MM		16 PCS
B	JCBC SCREW M6 x 35MM		4 PCS
C	SPRING WASHER M6 x 12MM		16 PCS
D	WOOD DOWEL M8 x 30MM		4 PCS
E	WOOD DOWEL M8 x 20MM		4 PCS
F	PAN HEAD M4 x 32MM		8 PCS
G	M4 ALLEN KEY (100MM)		1 PC

There are total **THREE (3)** packs of hardware packs.
 Each hardware pack includes the hardware for **TWO (2)** chairs.

ASSEMBLY INSTRUCTION

PARTS LIST

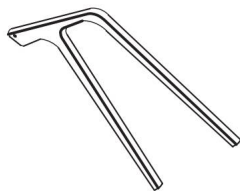
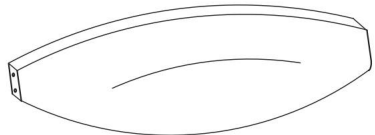
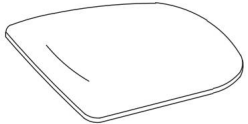
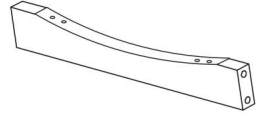
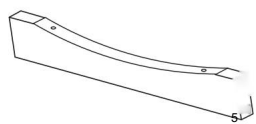
ITEM	DESCRIPTION	DRAWING	QTY
1	RIGHT LEG		6 PCS
2	LEFT LEG		6 PCS
3	BACK REST		6 PCS
4	CUSHION SEAT		6 PCS
5	FRONT APRON		6 PCS
6	BACK APRON		6 PCS

ASSEMBLY INSTRUCTION

PARTS ' LOCATION

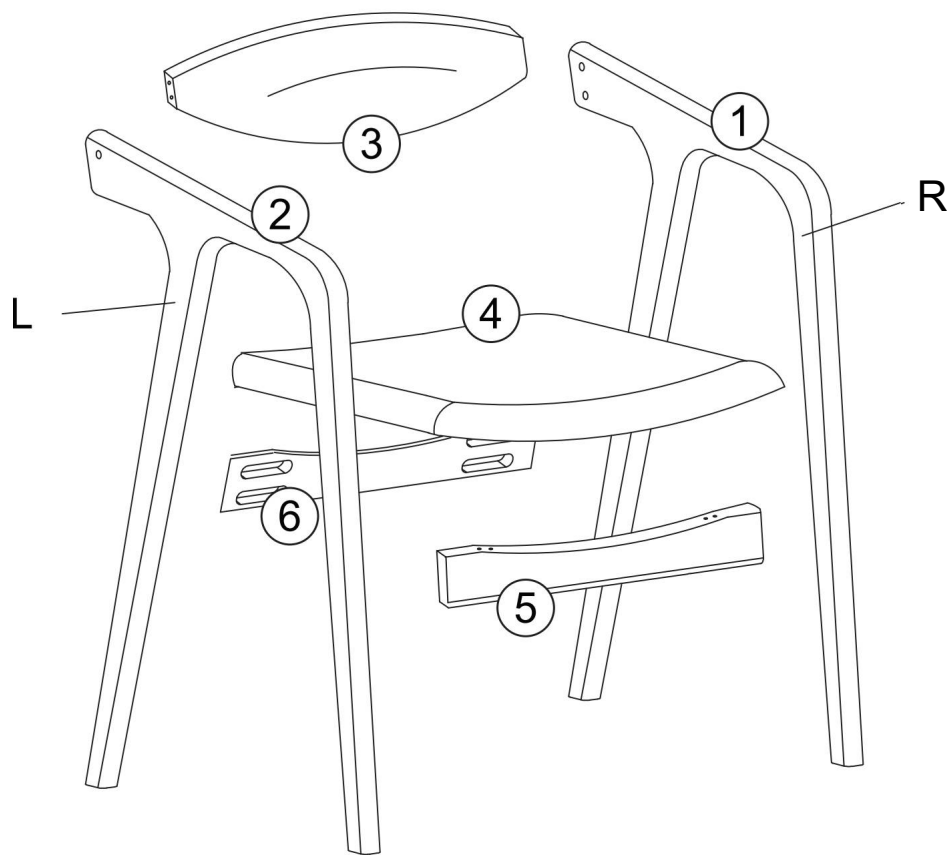

ASSEMBLY INSTRUCTION

STEP 1

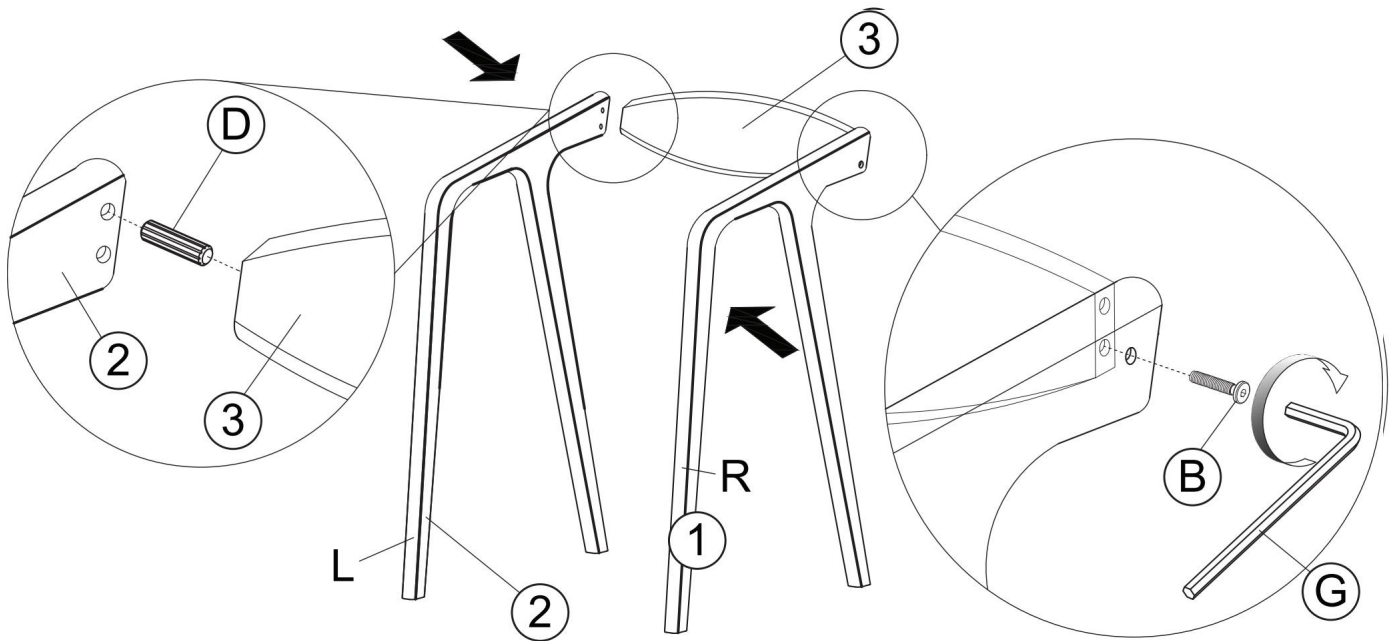

STEP 2

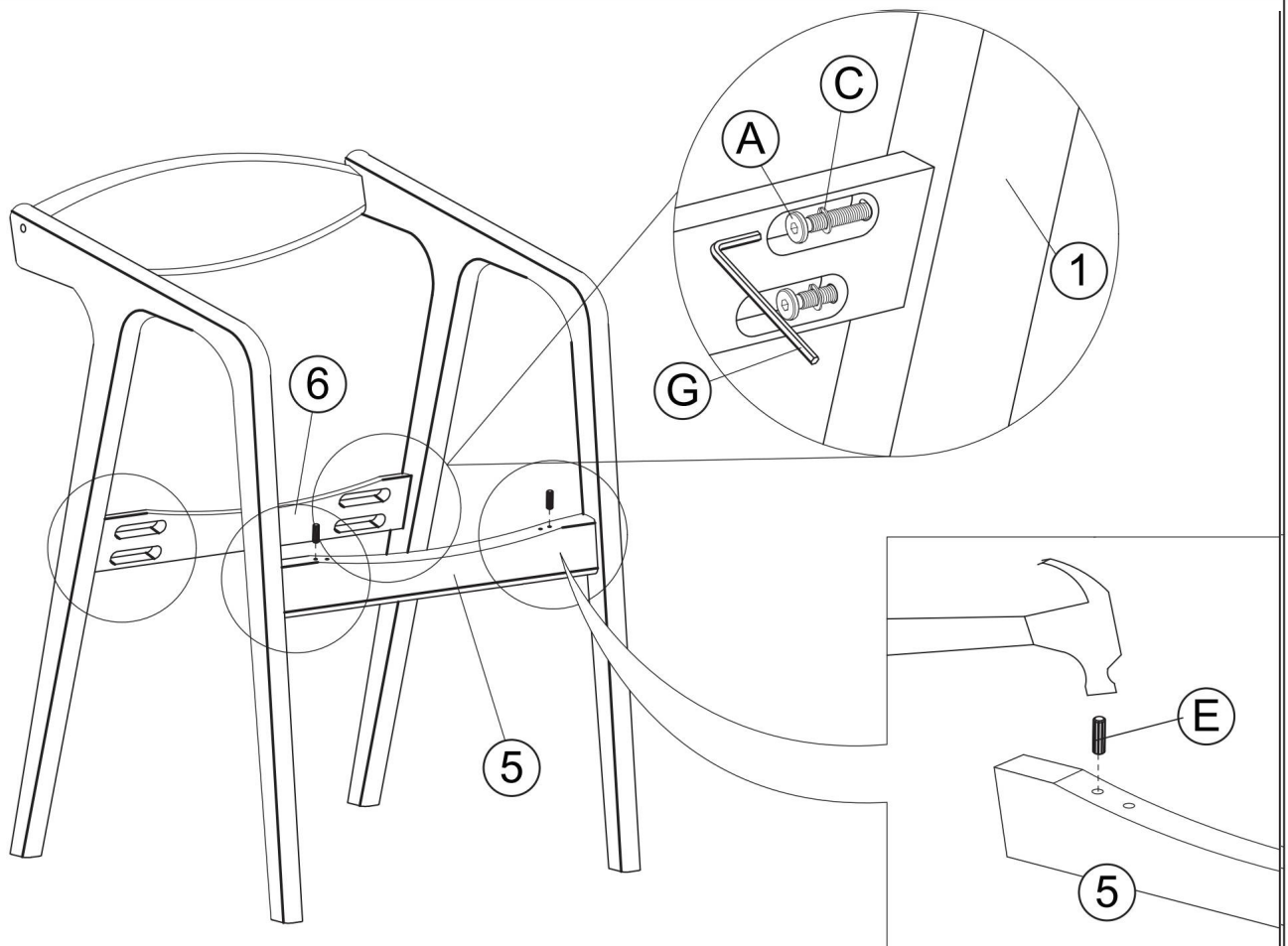

ASSEMBLY INSTRUCTION

STEP 3

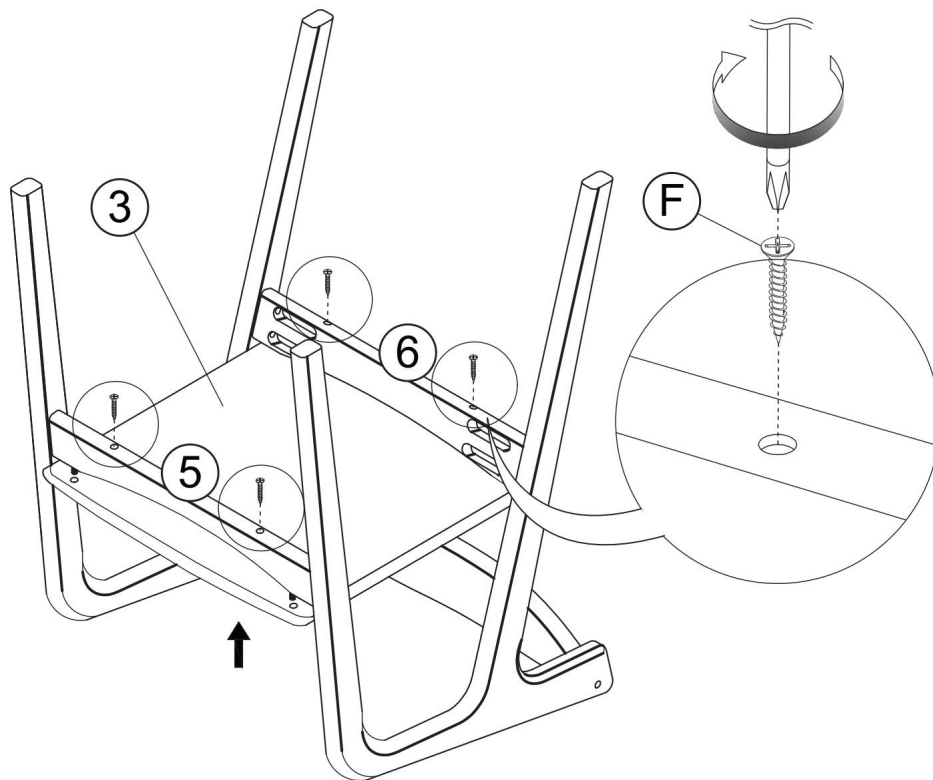

STEP 4

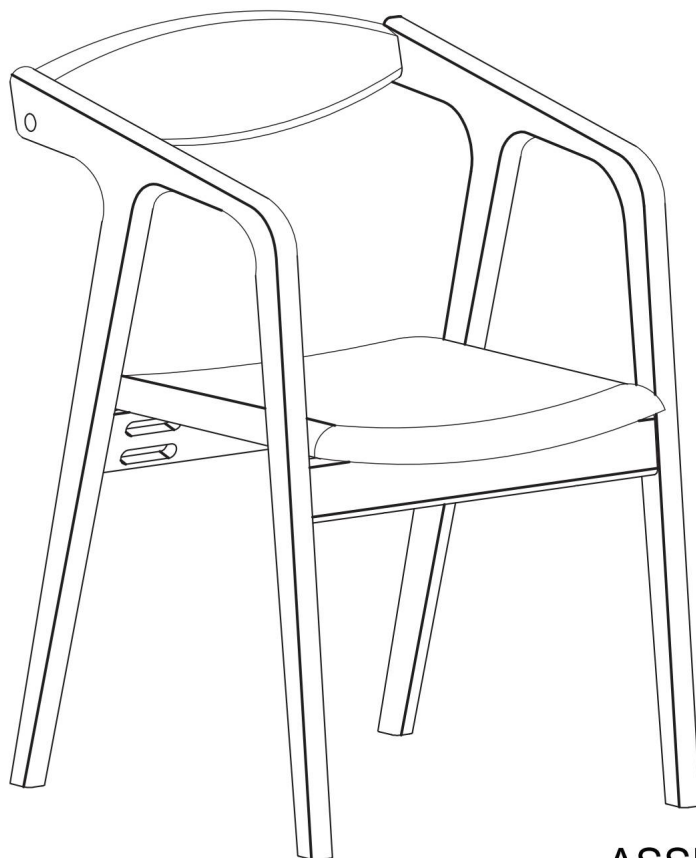

ASSEMBLY COMPLETED