

# *ASSEMBLY INSTRUCTIONS*

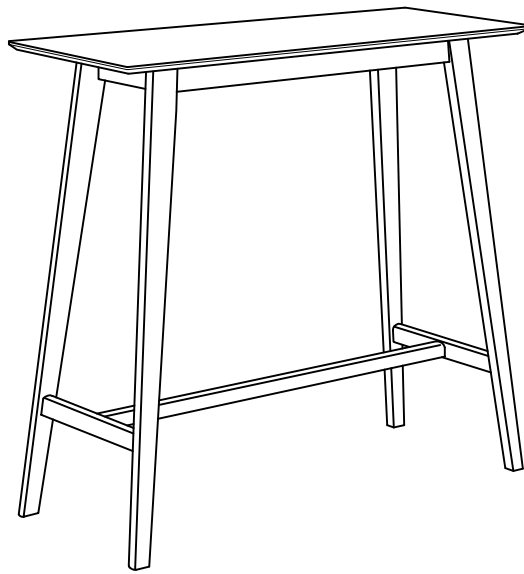

## ***Bar Table***

# ASSEMBLY INSTRUCTIONS

## ASSEMBLY TIPS :

1. Remove hardware from box and sort by size.
2. Please check to see that all hardware and parts are present prior to start of assembly.
3. Please follow attached instructions in the same sequence as numbered to assure fast & easy assembly.



### WARNING !



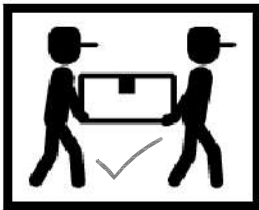

1. Don't attempt to repair or modify parts that are broken or defective. Please contact the store immediately.
2. This product is for home use only and not intended for commercial establishments.





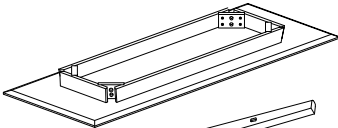

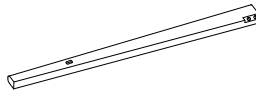

ASSEMBLY TIME

30 MINUTES

## PARTS IDENTIFICATION

AF	TOP		1PC
B	LEFT FRONT LEG AND RIGHT REAR LEG		2PCS
C	RIGHT FRONT LEG AND LEFT REAR LEG		2PCS
DF	LONG TRESTLE BAR		1PC
E	SHORT TRESTLE BAR		2PCS

## HARDWARE IDENTIFICATION

1	ALLEN WRENCH (M4 x 110MM - BLK)		1PC
2	LONG BOLT (M6 x 70MM - RBW)		8PCS
3	SHORT BOLT (M6 x 50MM - RBW)		2PCS
4	LOCK WASHER (1/4" - BLK)		10PCS
5	SMALL FLAT WASHER (M6 X 13MM - RBW)		2PCS
6	BIG FLAT WASHER (5/16" - RBW)		8PCS
7	PAN HEAD SCREW (#8 x 1 1/2" -BLK )		4PCS

### NOTE :

Phillips head screw driver is required in the assembly process ; However, manufacturer not provide this item.

# ASSEMBLY INSTRUCTIONS

## STEP 1

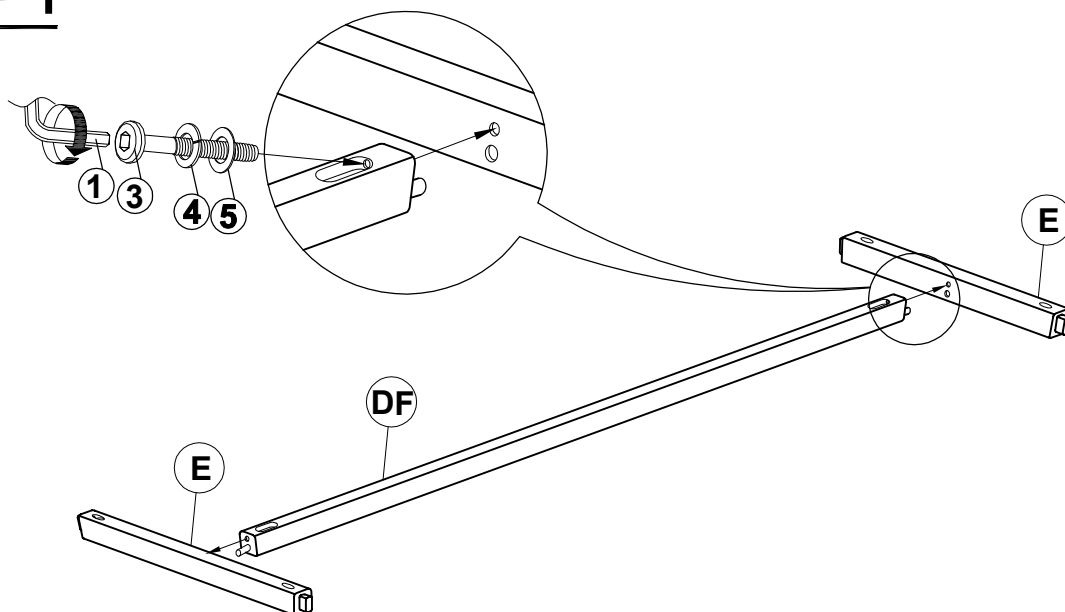

## STEP 2

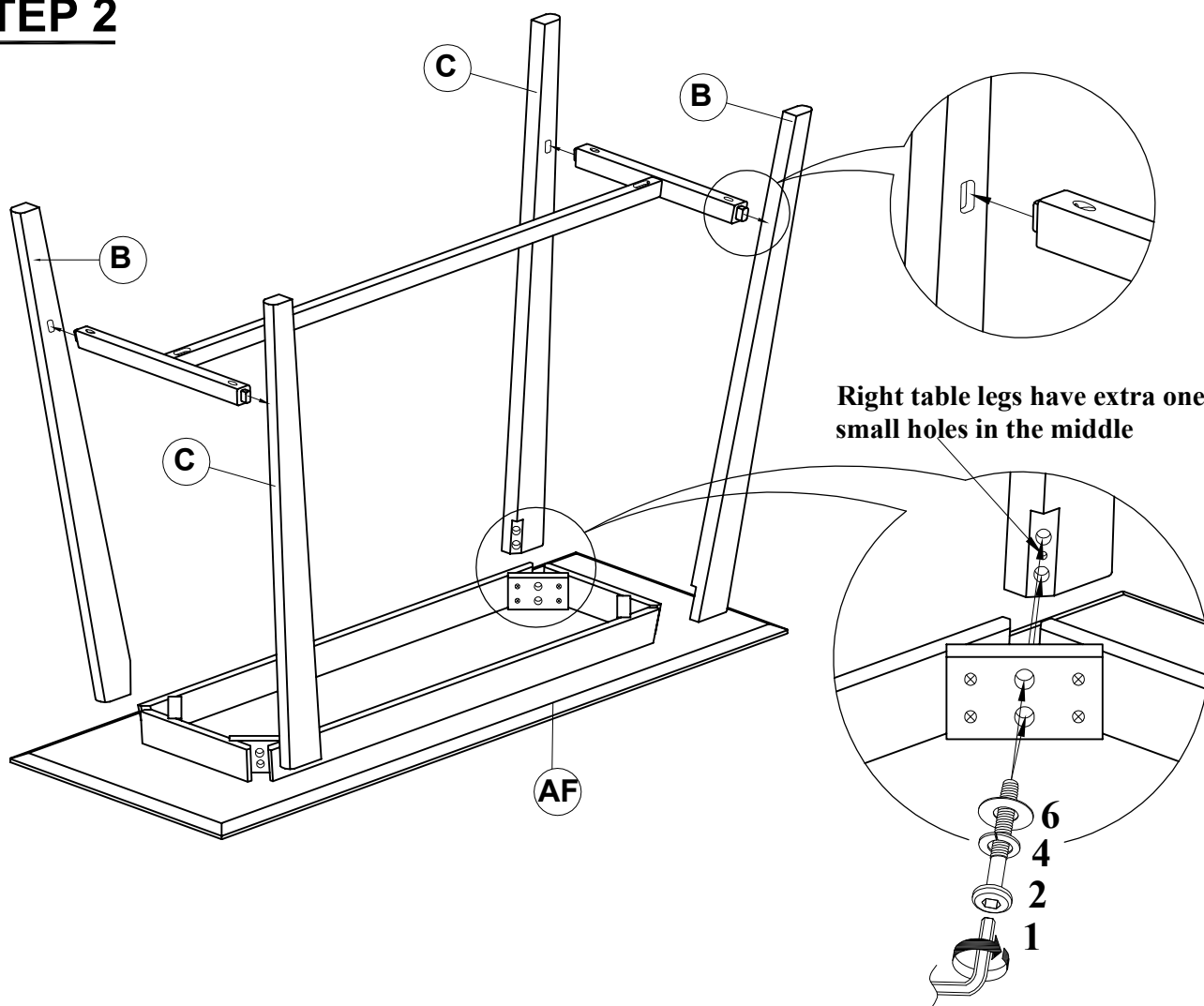

# ASSEMBLY INSTRUCTIONS

## STEP 3

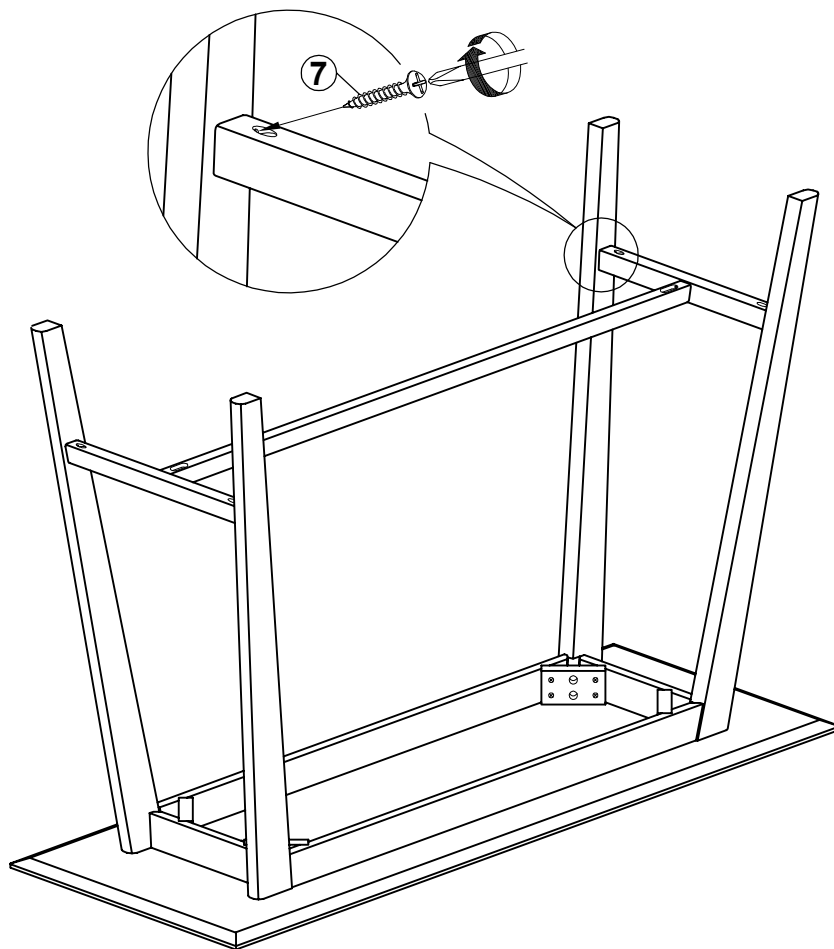

## STEP 4 COMPLETE

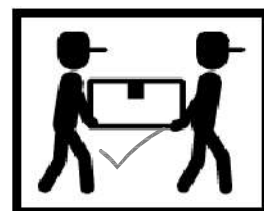
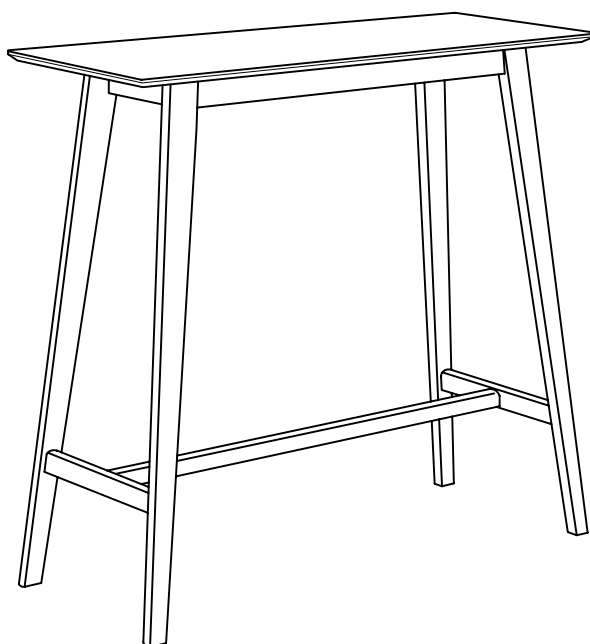

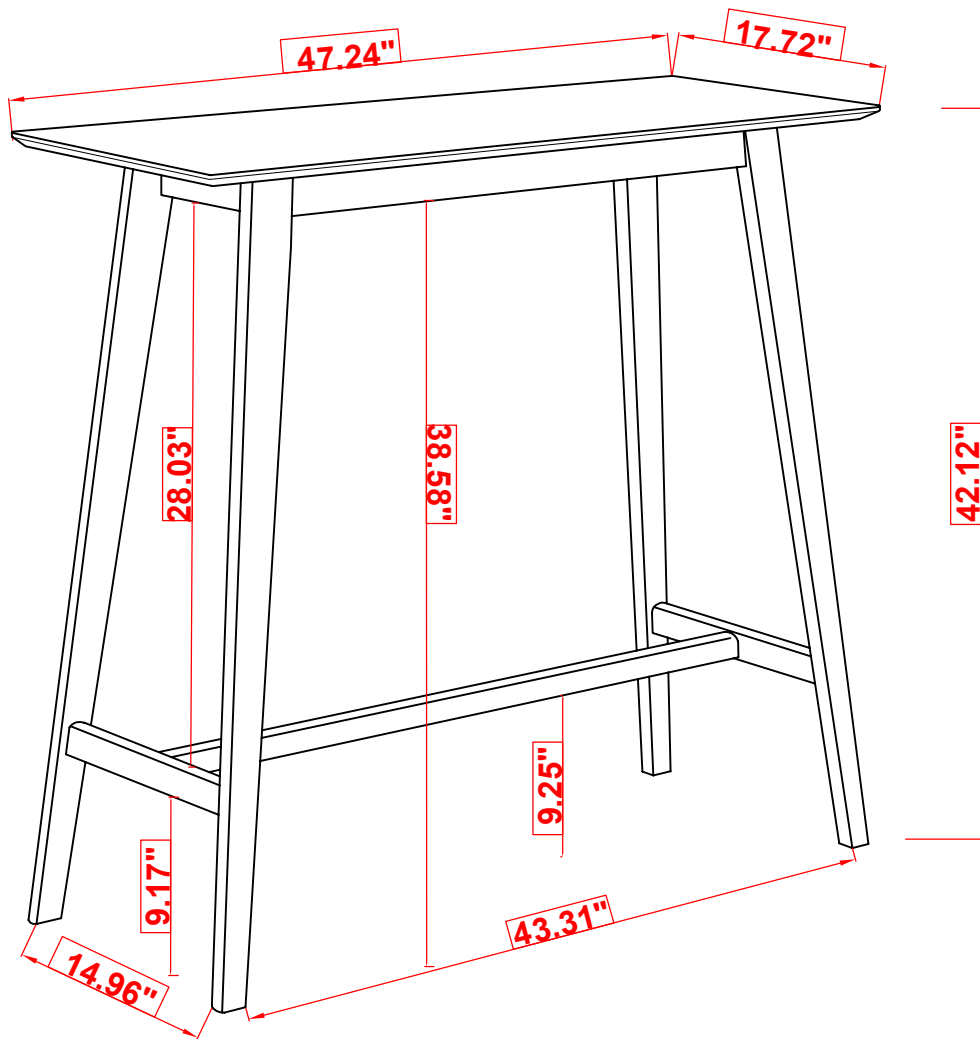

**Note :** Dimension tolerance  $\pm 5\%$