

ASSEMBLY INSTRUCTIONS

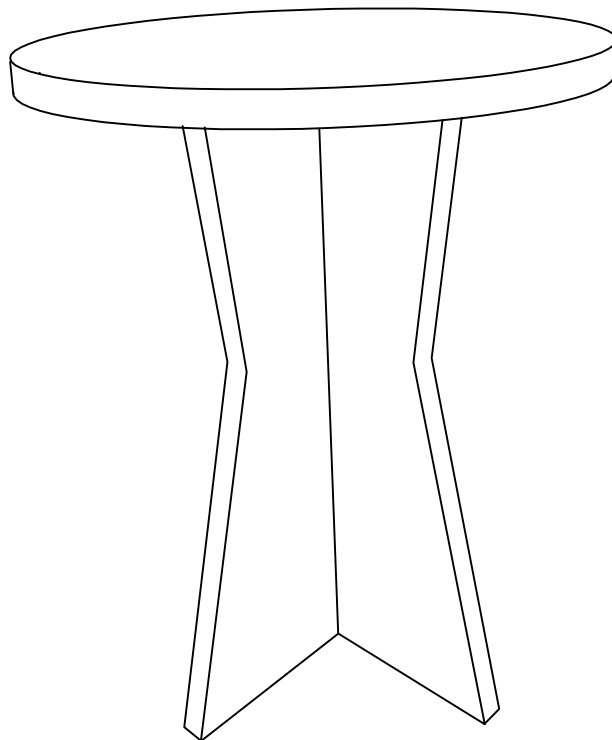

NOTE TO CUSTOMERS:

- For ease and speed of assembly we recommend that before you commence each step of the assembly that you identify all the parts required to complete that step.
- We recommend that where possible you allow sufficient space to assemble the item as close as possible to the place where it will be once assembled.
- For the protection of your furniture we recommend that the product is placed on protected surfaces during assembly to prevent any damage.
- During assembly do not over tighten, as this may damage the product.
- Please ensure you retain all the product packaging until the item completely assembled.
- Please periodically check all fittings and re-tighten as necessary.
- It is recommended that this item should be assembled by two adults.

To insert a cam lock: (Please read below instructions before assembling)

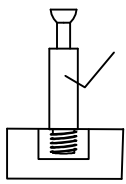
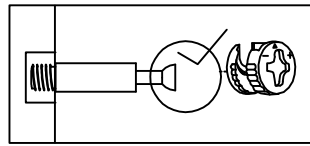

Diagram A



1. Insert cam screw into hole as shown in diagram A .

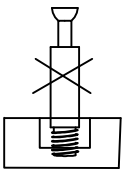
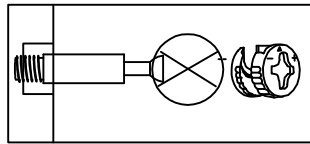

Diagram B



Make sure not to insert the cam screw:
Too deep as shown in figure B as this will cause the
cam screw to be misaligned and unable to
interlock properly.

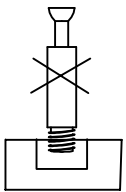
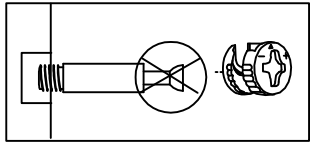
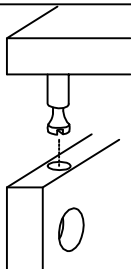

Diagram C



Also avoid inserting the cam screw too close to the
surface of the hole as shown in figure C, as this will
cause the cam lock to be too loose, and not interlock
properly.



2. Connect the panels together.

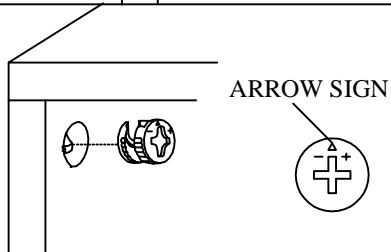

3. When inserting the cam lock make sure the arrow
of the cam lock faces the cam screw.

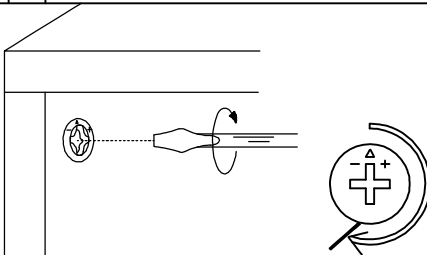

4. To tighten the cam lock turn the cam lock clockwise
90-180 degree or until the arrow is facing opposite
the place cam lock was inserted.

**NOTE: DO NOT USE AN AUTOMATIC
SCREWDRIVER TO TIGHTEN CAM LOCKS.**

Part List

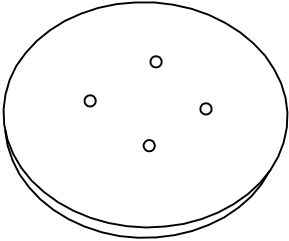
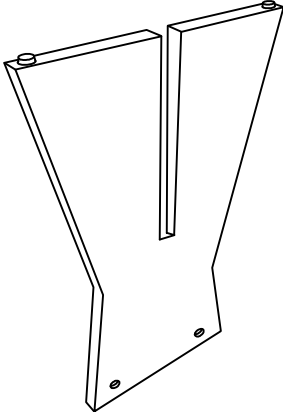
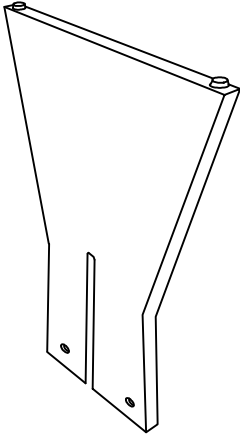
<p>A1</p> <p>Quantity of 1</p>  <p>Top Panel</p>	<p>A2</p> <p>Quantity of 1</p>  <p>Leg</p>	<p>A3</p> <p>Quantity of 1</p>  <p>Leg</p>
---	---	---

Hardware List

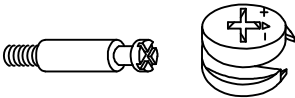
<p>B1</p> <p>Quantity of 4</p>  <p>Camlock</p>

Assembly instructions

Step 1

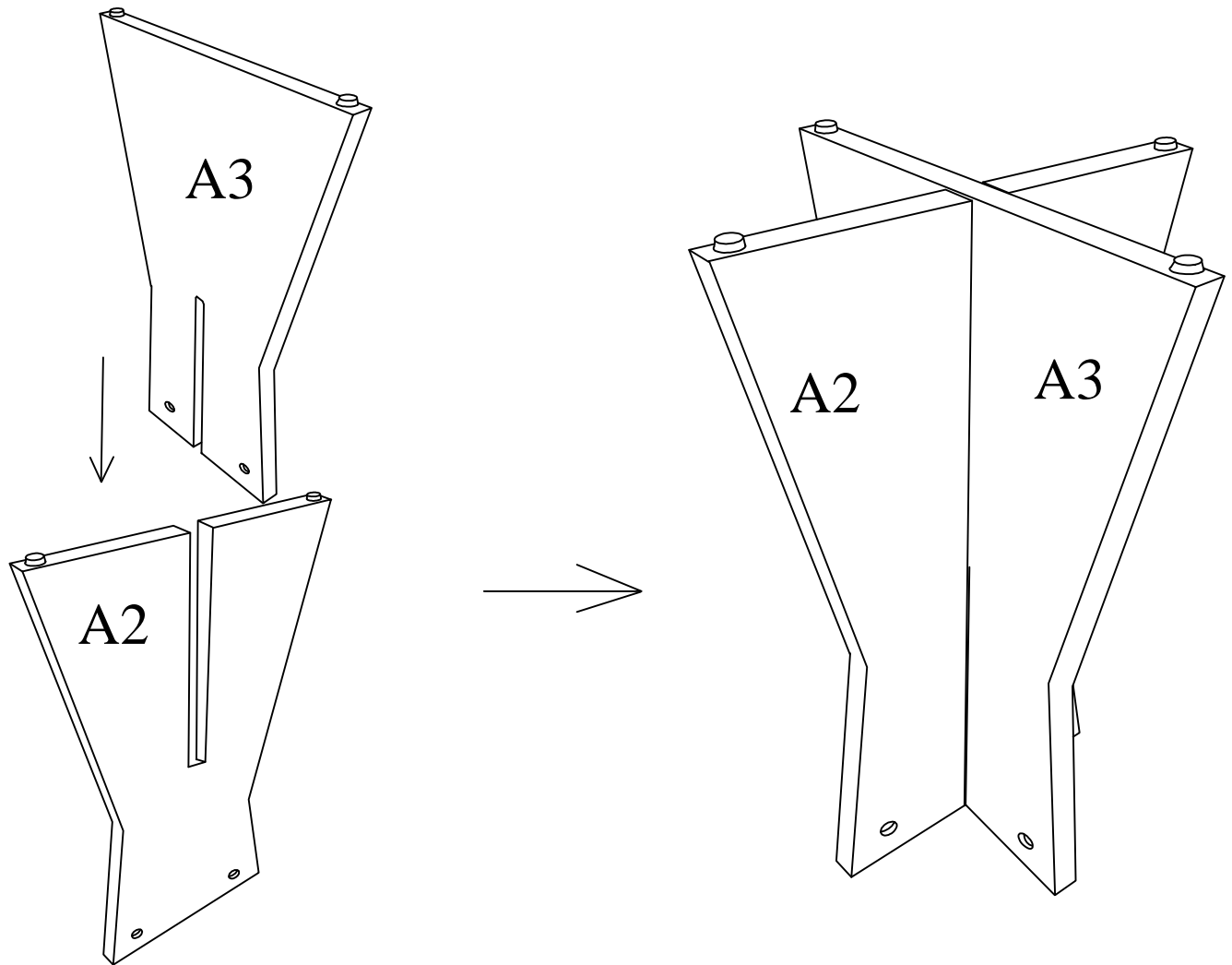

Insert Leg A1 into groove on Leg A2 as shown above.

Step 2

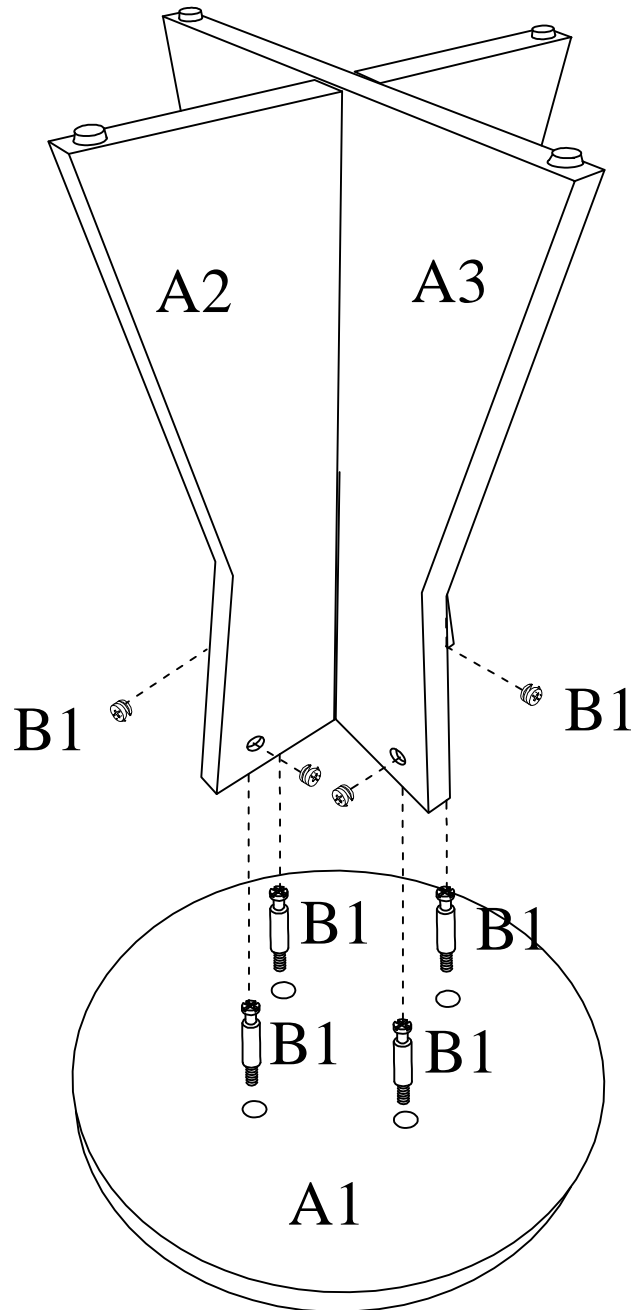
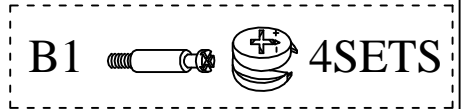

Assemble Legs A1 & A2 to Top Panel A1 using Cam-locks B1 as shown above.