

# BED FRAME

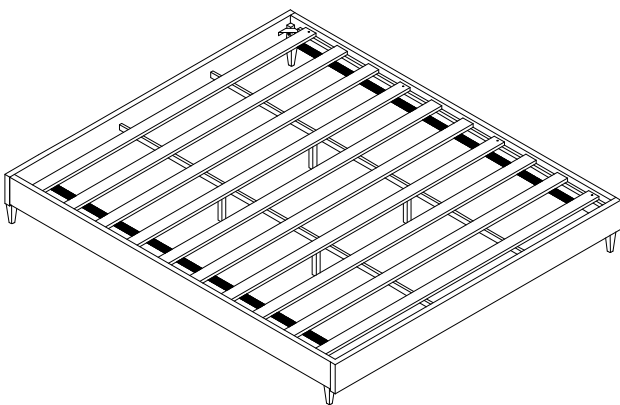







Thank you for purchasing the **KING BED FRAME** !

Before you start, here is some helpful advice:

1. We suggest you spend a short time reading through this leaflet and then follow the simple step by step instructions.
2. Owing to the size and weight of the bed frame, we recommend that it is assembled by two adults, on a carpeted or padded area, in the room that it is intended for. Approx assembly time: 45 minutes.
3. Please do not use any tools other than those provided or recommended in these instructions.
4. Please do not throw away any of the packaging or the instruction until you have checked all the components and hardware and the furniture is fully assembled. Please ensure that the packaging is disposed of in a safe environmentally friendly way.
5. Assemble all components loosely until advised to tighten. Depending on use, it may be necessary to tighten the components from time to time, so please save the tools that has been provided.
6. Please keep all fitting out of reach of children.



### Hardware:

A		Bolt M8x25mm	x16
B		Bolt M6x45mm	x16
C		Screw M4x35mm	x16
D		Flat Washer M6	x16
E		Flat Washer M8	x16
F		Spring Washer M8	x16
G		Allen Wrench M4	x1
H		Allen Wrench M5	x1

 PHILLIPHS HEAD SCREW DRIVER  
NOT PROVIDED

### Component:

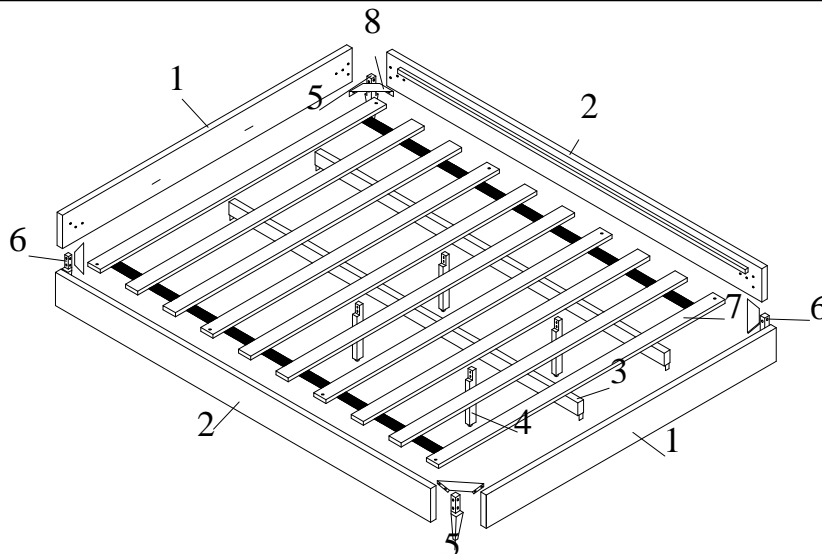

1	Short Board	x2	2	Long Board	x2	3	Center Rail	x2	4	Support Leg	x4
5	Leg I	x2	6	Leg II	x2	7	Slats	x10	8	Metal Corner Plate	x4

# BED FRAME

## STEP 1:

Put 1 piece of **Short Board (1)** upside down on a carpeted or padded area by two adults



Attach 1 piece of **Leg (5)** and 1 piece of **Leg (6)** into the **Short Board (1)** by using 4 pieces of **Bolt (B)** and 4 pieces of **Flat Washer (D)** as shown.

Use **Allen Wrench (G)** to tighten the **Bolts (B)** clockwise until secure.

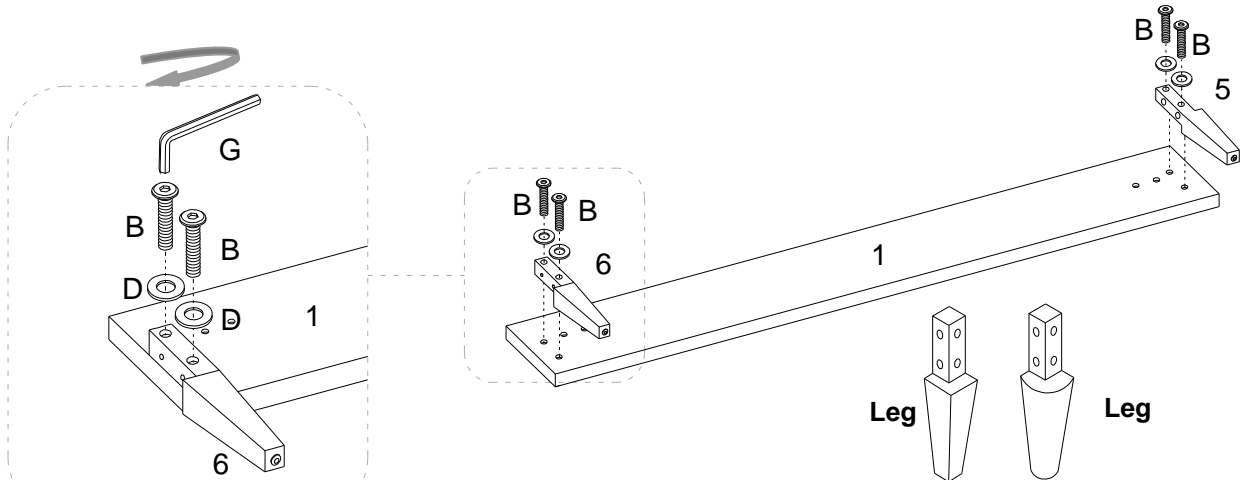
Repeat the same steps for the remaining 1 piece of **Short Board (1)**, 1 piece of **Leg (5)** and 1 piece of **Leg (6)**.



**Note:** There are two kinds of legs designed for this Bed Frame.

		
Bx8	Dx8	Gx1

Hardware & Tool required

## STEP 2:



Place 1 piece of **Long Board (2)** to 2 pieces of assembled **Short Board (1)** by two adults

Attach them by using 4 pieces of **Bolt (B)** and 4 pieces of **Flat Washer (D)** as shown.

Use **Allen Wrench (G)** to tighten the **Bolts (B)** clockwise until secure.

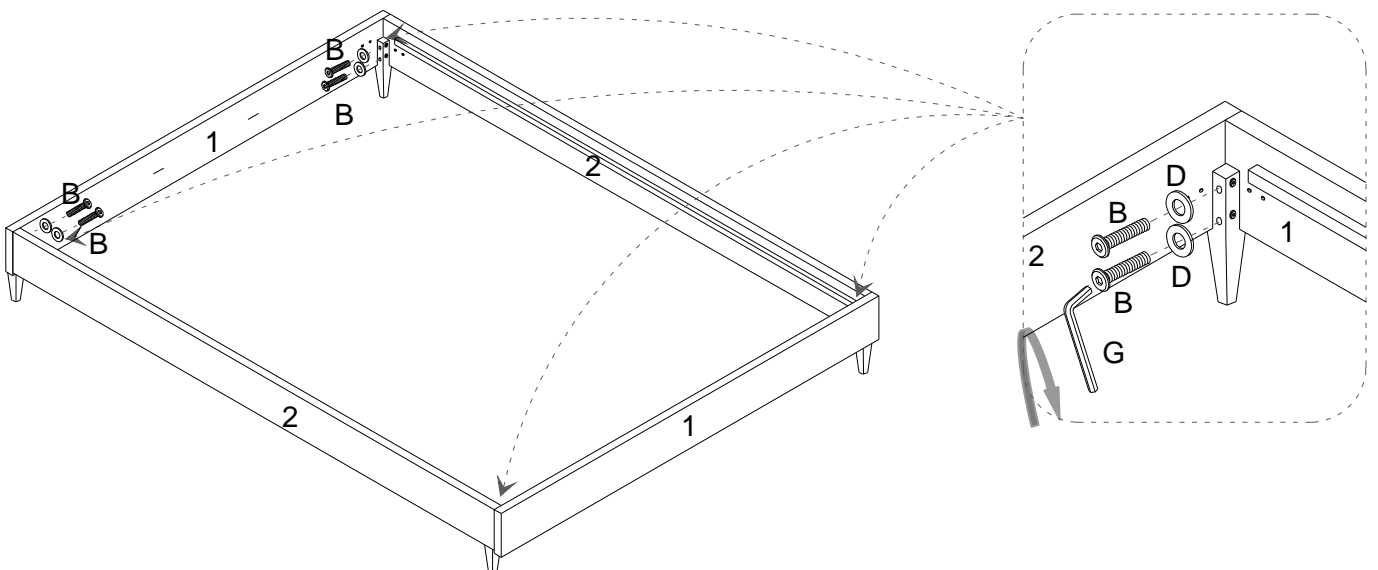
Repeat the same steps for the remaining 1 piece of **Long Board (2)**.



		
Bx8	Dx8	Gx1

Hardware & Tool required

# BED FRAME

## STEP 3:

Attach 1 piece of **Support Leg (4)** into the **Center Rail (3)** as shown.



Secure the **Support Leg (4)** into the **Center Rail (3)** by using 2 pieces of **Screw (C)** as shown.

Tighten the **Screws (C)** with Phillips Head Screw Driver (Not provided).

Repeat the same steps for the remaining 1 piece of **Support Leg (4)**.

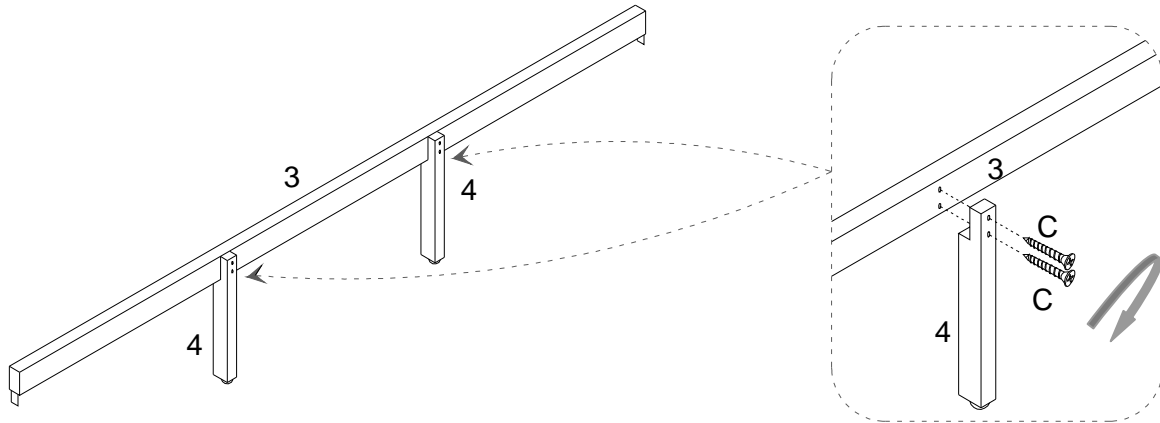
Repeat the same above steps for the remaining 1 piece of **Center Rail (3)** and 2 piece of **Support Leg (4)**.



	
Cx8	Phillips Head Screw Driver (not provided)

Hardware & Tool required

## STEP 4:

Secure 1 piece of **Metal Corner Plate (8)** into the **Short Board (1)** and **Long Board (2)** by using 4 pieces of **Bolt (A)**

with 4 pieces of **Spring Washer (F)**, 4 pieces of **Flat Washer (E)** as shown.

Repeat the same steps for the remaining 3 pieces of **Metal Corner Plate (8)**.

Place the assembled **Center Rails (3)** to the **Short Board (1)**.

Insert the hook on the each end of **Center Rail (3)** into the notch on the **Short Board (1)**.

Repeat the same steps for the remaining assembled **Center Rail (3)**.

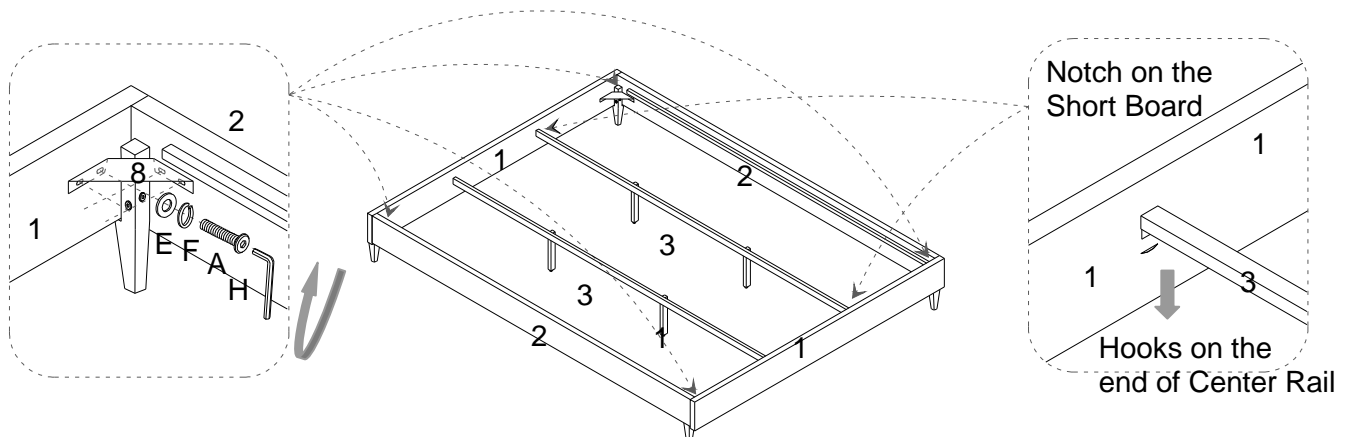

			
Ax16	Ex16	Fx16	Hx1

Hardware & Tool required

# BED FRAME

## STEP 5:

Place the **Slats (7)** to the **Long Boards (2)** as shown.

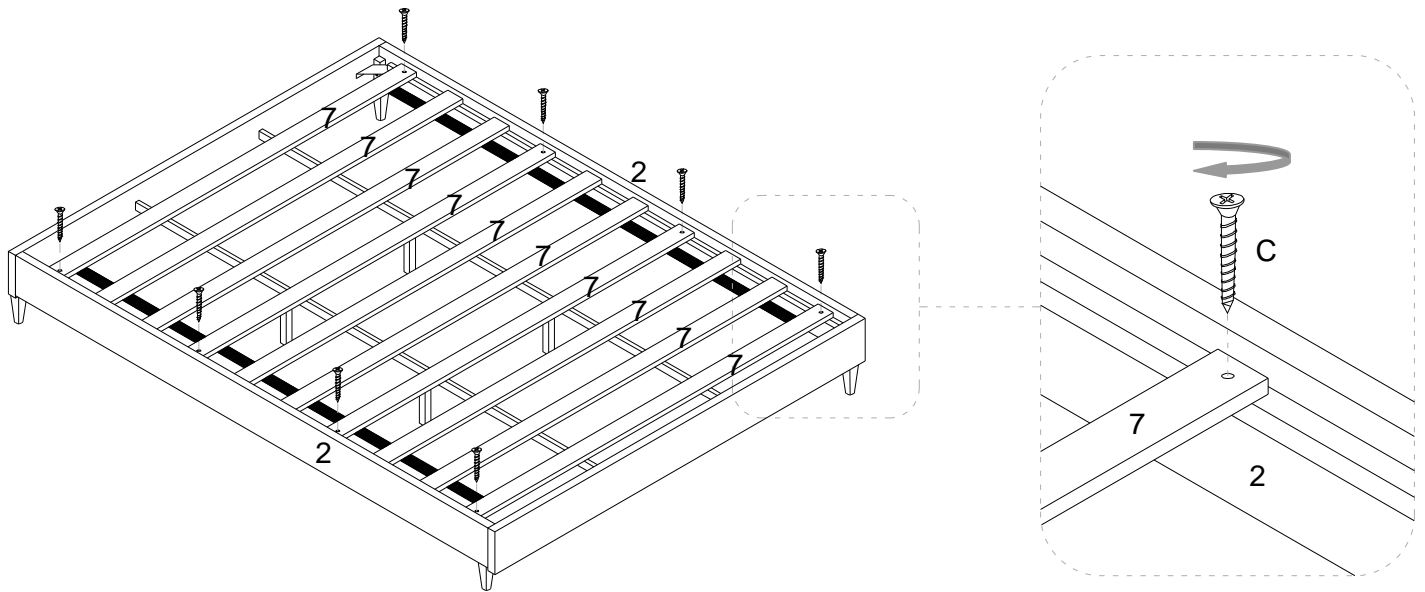

Secure 4 pieces of **Slat (7)** which have countersink Holes on each end into the **Long Board (2)** by using 8 pieces of **Screw (C)** as shown.

Tight the **Screw (C)** with Phillips Head Screw Driver (Not provided).



Assembly is completed. The bed frame is ready to use now!

**NOTE:** Hardware may loosen over time. Periodically check that all connections are tight.

	
Cx8	Phillips Head Screw Driver( not provided)



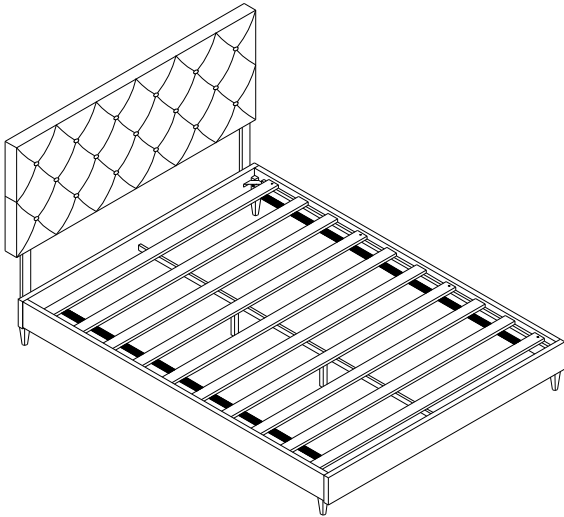

Hardware & Tool required

ASSEMBLY INSTRUCTIONS

**Note:** This is assembly instruction for Full/Twin/Queen/King Bed Frame to connect Headboard.



Hardware:

A		Bolt M6x45mm	x4
C		Flat Washer M6xD22mm	x4
D		Spring Washer M6	x4
F		Allen Wrench M4	x1

**Important:** All the hardware is packed with the headboard you are buying. Please only use the above hardware from Headboard Hardware Package to assemble the Bed Frame and Headboard.

Component:

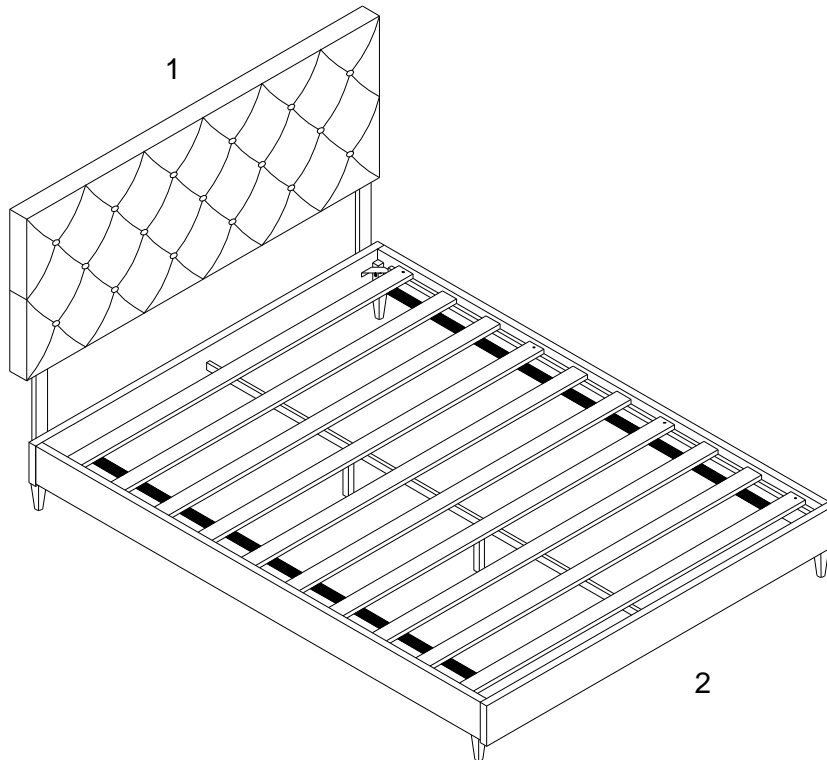

1 Headboard x1  
(Style may vary)

2 Bed Frame x1  
(Style may vary)

## CONNECTING BED FRAME TO HEADBOARD

### STEP 1:





Line up the **Bed Frame (2)** board's pre-drilled holes to match those of the **Headboard (1)**.

Secure the **Headboard (1)** to the **Bed Frame (2)** by using 2 pieces of **Bolt (A)** with 2 pieces of **Spring Washer (D)**, 2 pieces of **Flat Washer (C)** into the **Bed Frame (2)**.

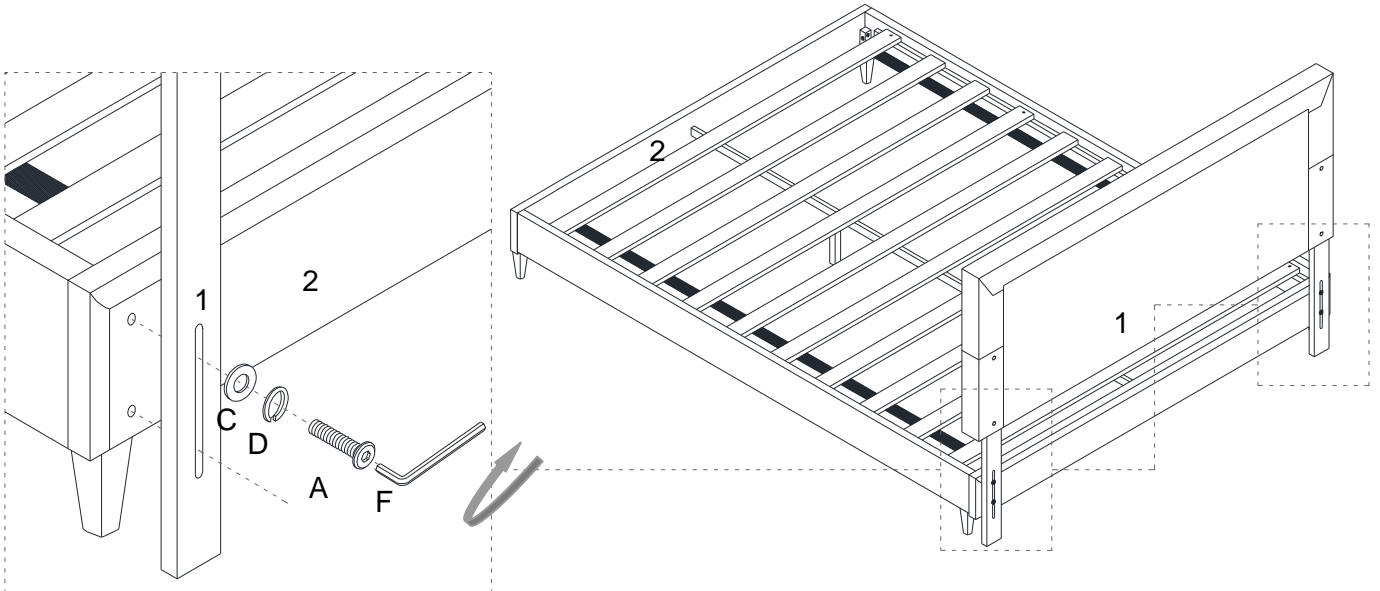
Then tighten the **Bolts (A)** by using the **Allen Wrench (F)**.

Repeat the same procedure for each bolt and each side of the **Bed Frame (2)**.



			
Ax4	Cx4	Dx4	Fx1

Hardware & Tool required

### STEP 2:

Carefully position the assembled bed to the desired location by four adults.

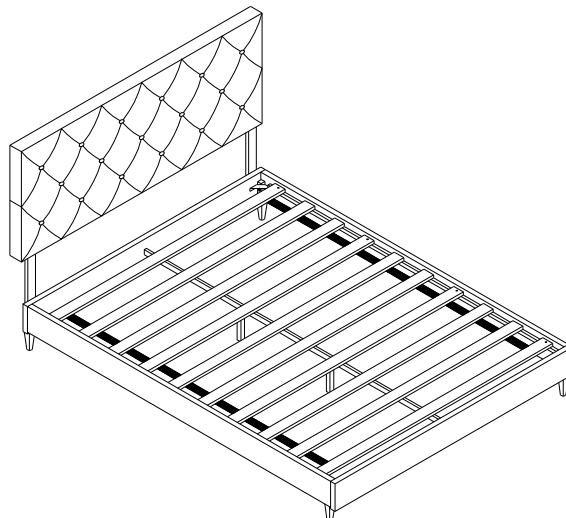

Assembly is completed. The bed is ready to use now!

**NOTE:** Hardware may loosen over time. Periodically check that all connections are tight.