

# USER MANUAL

## BENUTZERHANDBUCH

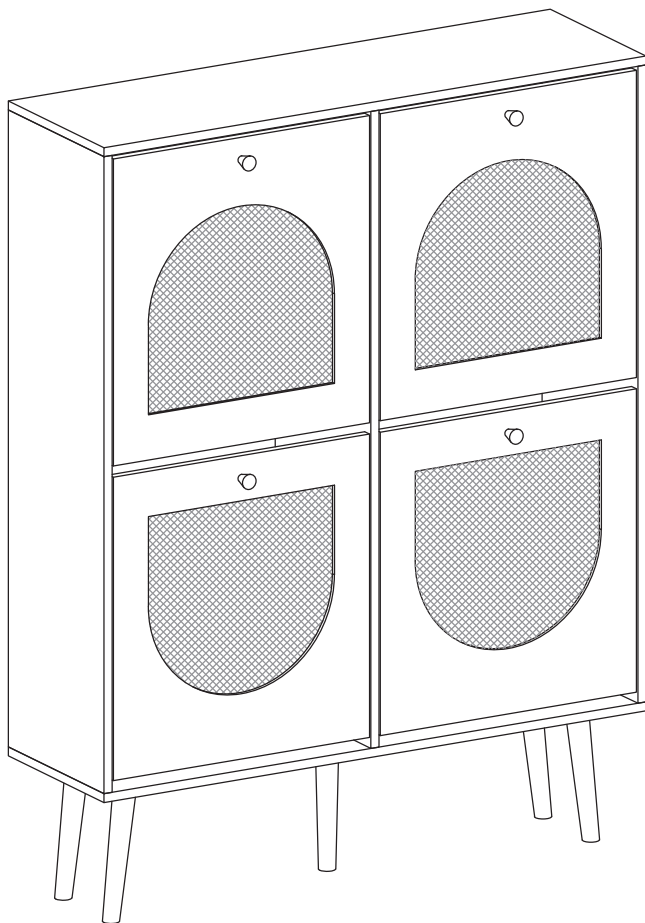

Please read, understand, and practice the guidelines in this user manual before use, and keep it for future reference.

Bitte lesen Sie die Richtlinien in dieser Bedienungsanleitung vor der Verwendung, verstehen Sie sie und setzen Sie sie um. Bewahren Sie die Anleitung für den späteren Gebrauch auf.



# Table of Contents/Inhaltsverzeichnis

- Important/Hinweise ..... 2
- Parts List/Teileliste ..... 3
- Assembly/Montage ..... 7
- Warranty/Garantie ..... 17





## Important/Hinweise





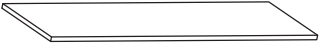



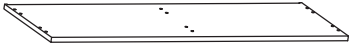
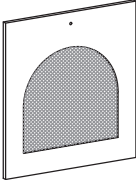
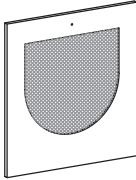

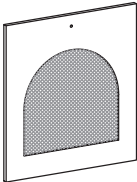
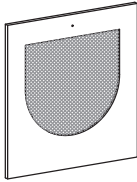
We'd love to hear from our customers. If you have any questions about the manual, would like us to help in any way, or have any suggestions and comments about our products, please feel free to contact the support team [2maxlead.uk@gmail.com](mailto:2maxlead.uk@gmail.com) and we'll get back to you within 24 hours (weekdays).









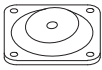

## Hinweise

Wir hören gern von unseren Kunden. Wenn Sie Fragen zum Handbuch haben, wir Ihnen auf irgendeine Weise helfen sollen oder Sie Anregungen und Kommentare zu unseren Produkten haben, kontaktieren Sie bitte uns und wir werden innerhalb von 24 Stunden (Werktag) antworten.

# Part List/Teileliste

Part Number	Diagram	Description	Quantity (PCS)
Teilenummer	Bild	Beschreibung	Menge (STK)
#1		Top Panel/ Obere Platte	1
#2		Side Panel/ Seitenwand	1
#3		Side Panel/ Seitenwand	1
#4		Middle Panel/ Mitteltrennwand	1
#5		Bottom Panel/ Untere Platte	1
#6		Door/Tür	1
#7		Door/Tür	1

#8		Door/Tür	1
#9		Door/Tür	1
#10		Drawer divide Panel/ Schubladentrennwand	8
#11		Inner Panel/ Innen Platte	4
#12		Wooden legs/ Holzbeine	5
#13		Back Panel/ Rückwand	2
#A		Cam/Nocke	6
#B		Wooden dowel/ Holzdübel	12
#C		Cam Lock/ Nockenschloss	6
#D		Screw 4*12 mm/ Schrauben	56
#E		Screw/Schrauben	29

#G		Metallmatten/ Metallmatten	4
#H		Metallmatten/ Metallmatten	1
#I		Screw 4*12 mm/ Schrauben	20
#J		Screw 4*35 mm/ Schrauben	6
#K&M		Positioning buckle/ Positionierungsschnalle	8
#N		Washer +Screw/ Unterlegscheibe + Schraube	8
#O		L-shaped Iron Plate/ L-förmige Eisenplatte	2
#P		Expansion screws/ Dehnschrauben	2
#Q		Door handle/ Türgriff& screw&schrauben	4
#L		Plastic Hinge/ Kunststoffscharnier	4
#R		Plastic Hinge/ Kunststoffscharnier	4

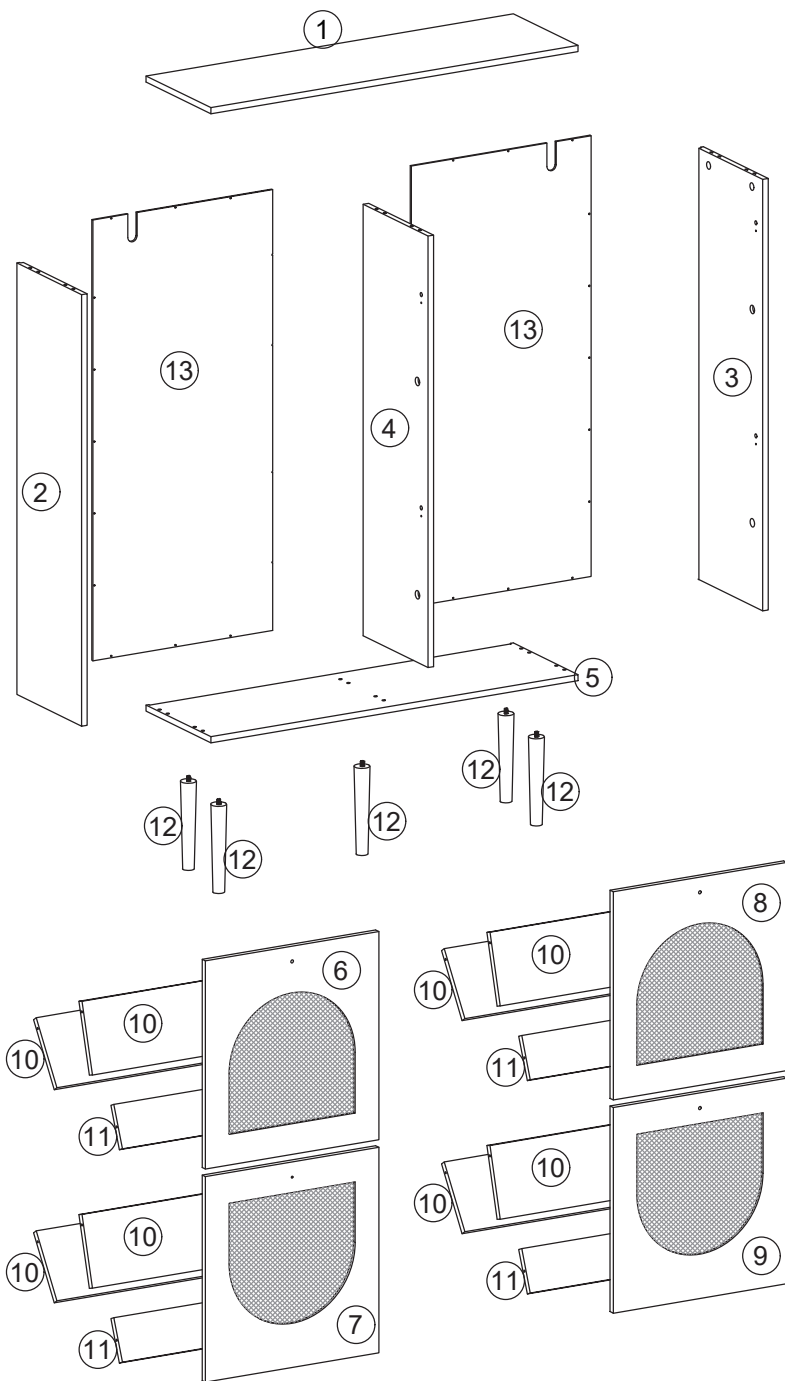

# Assembly/Montage

1

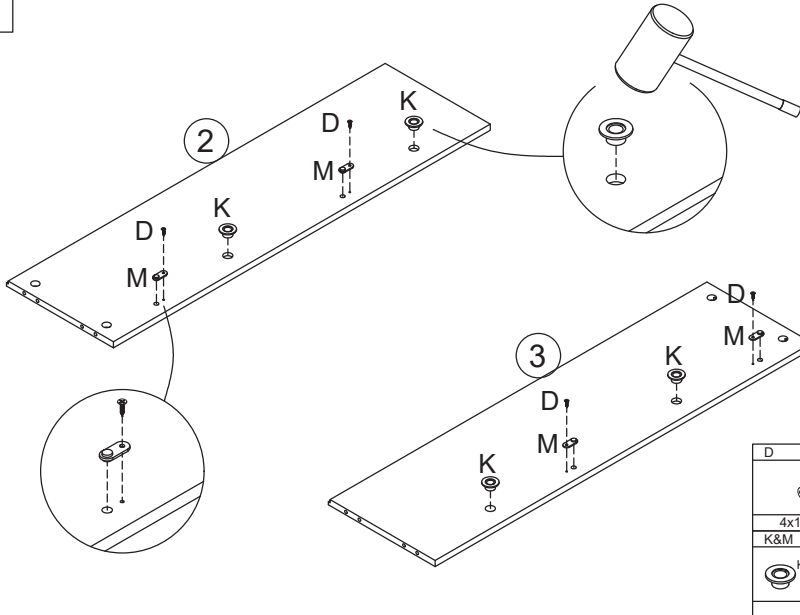

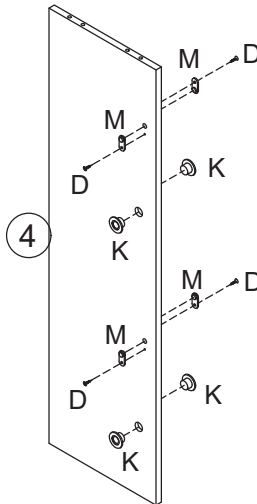

2



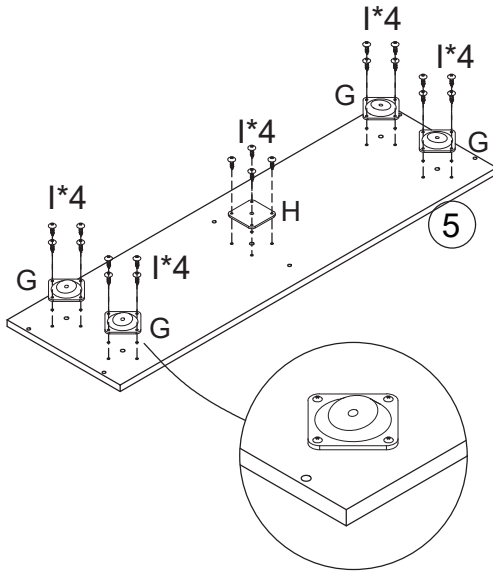

3

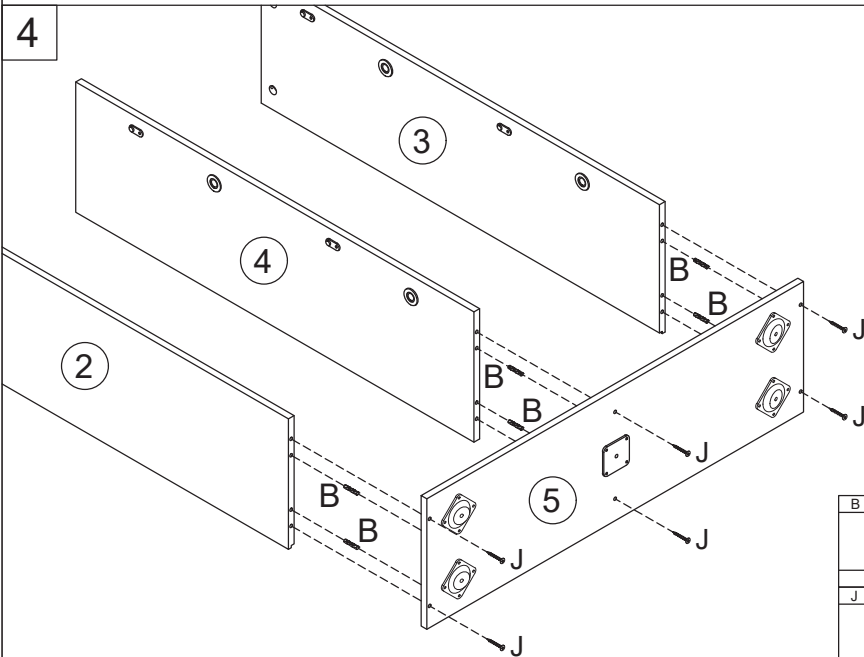

G	x4
	
H	x1
	
I	x20
	
4x12mm	

4



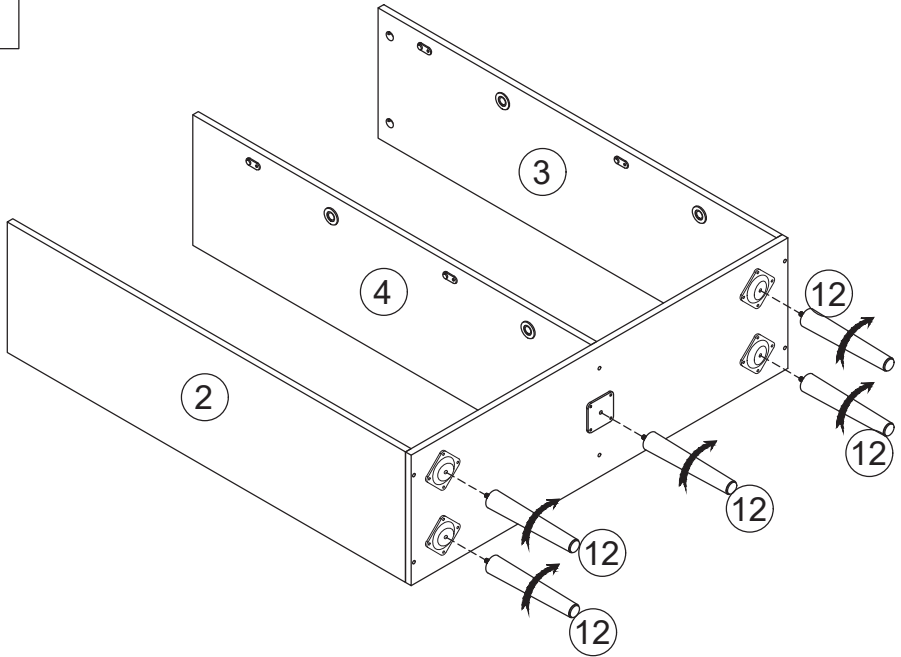

B	x6
	
J	x6
	
4x35mm	

5



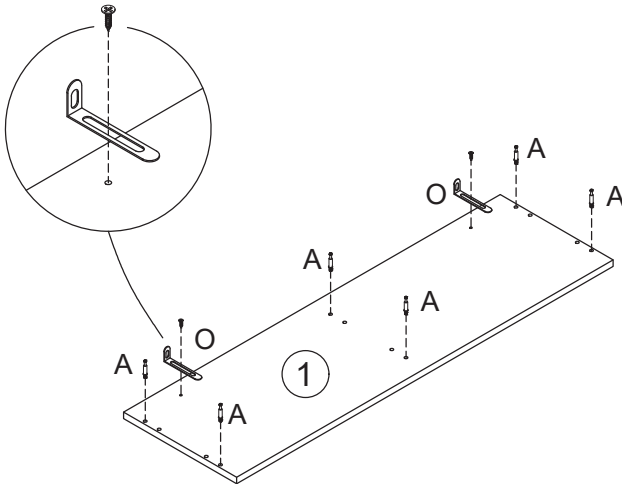

6

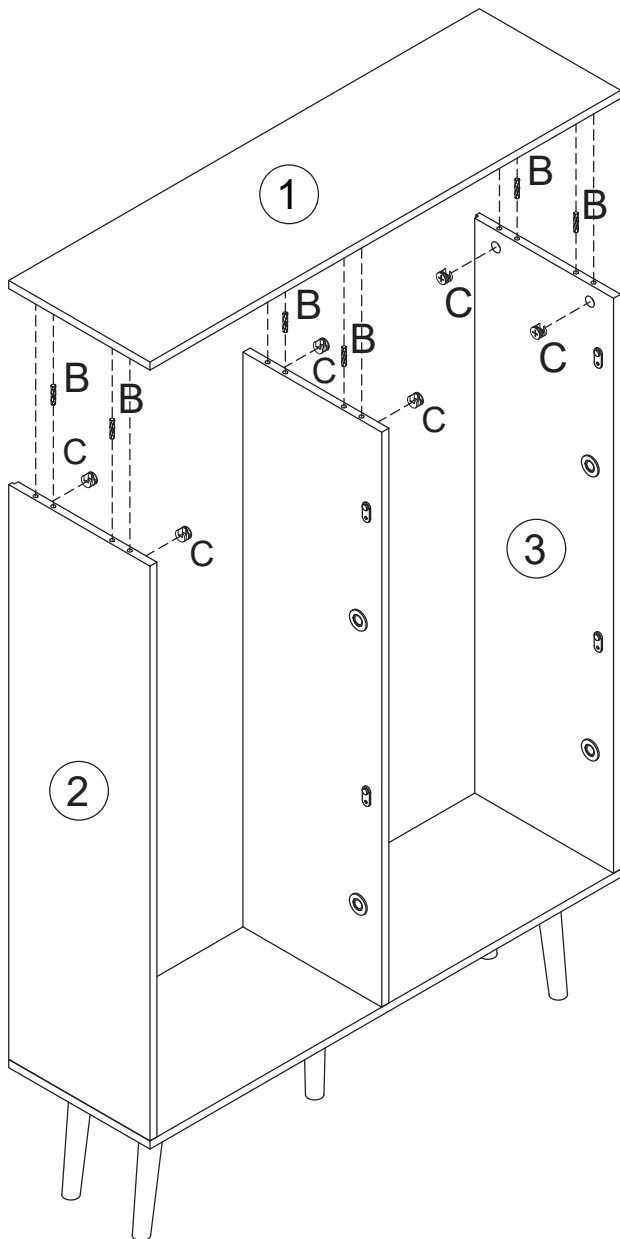

A	x6
	
O	x2
	

7



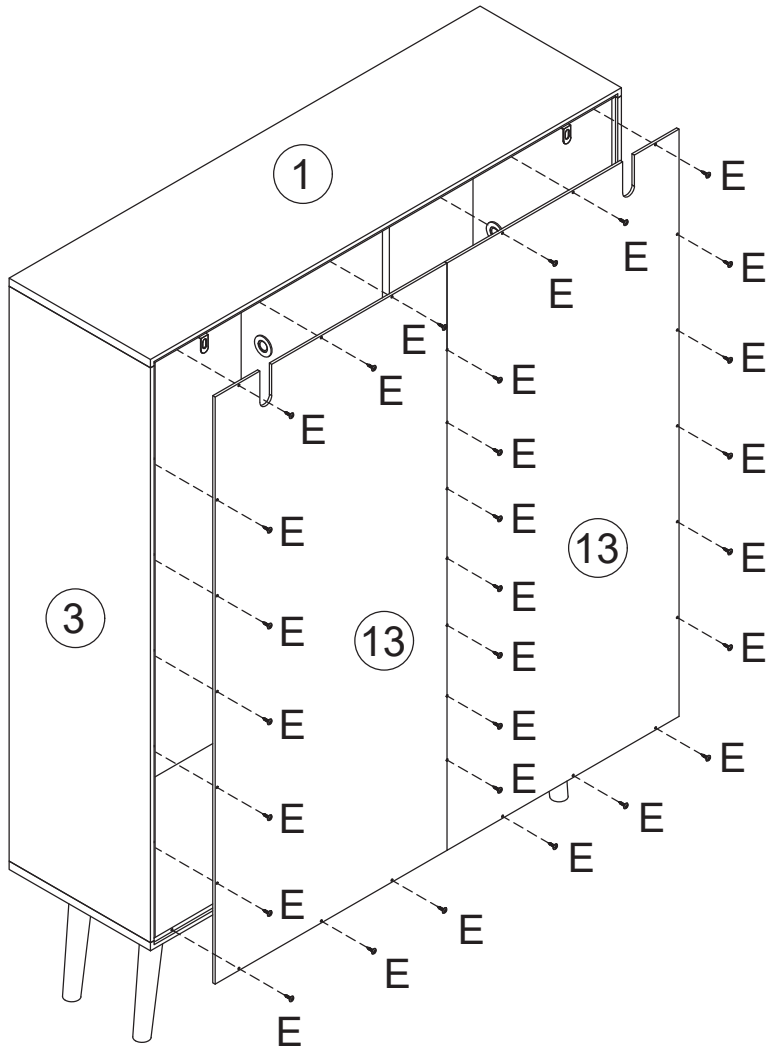

B	x6
	
C	x6
	

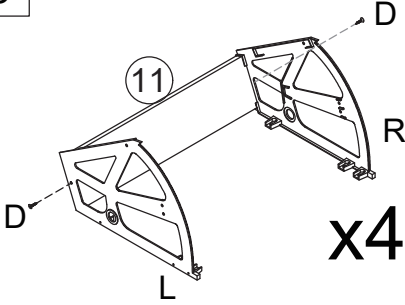

9



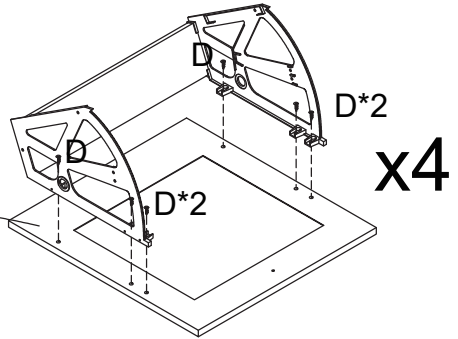
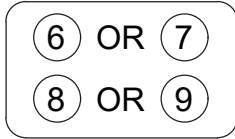

D	x32
	
4x12mm	
L	x4
	
R	x4
	



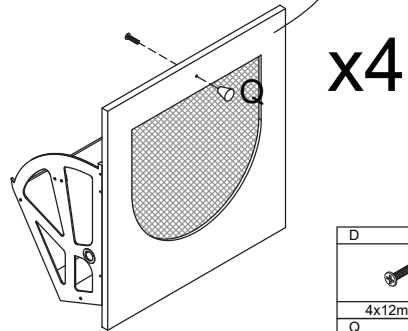
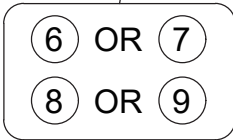
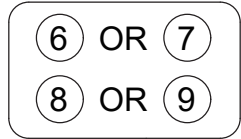
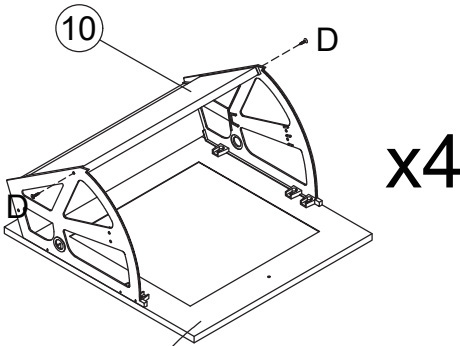

10



D	x8
	
4x12mm	
Q	x4
	

11

N	x8
	

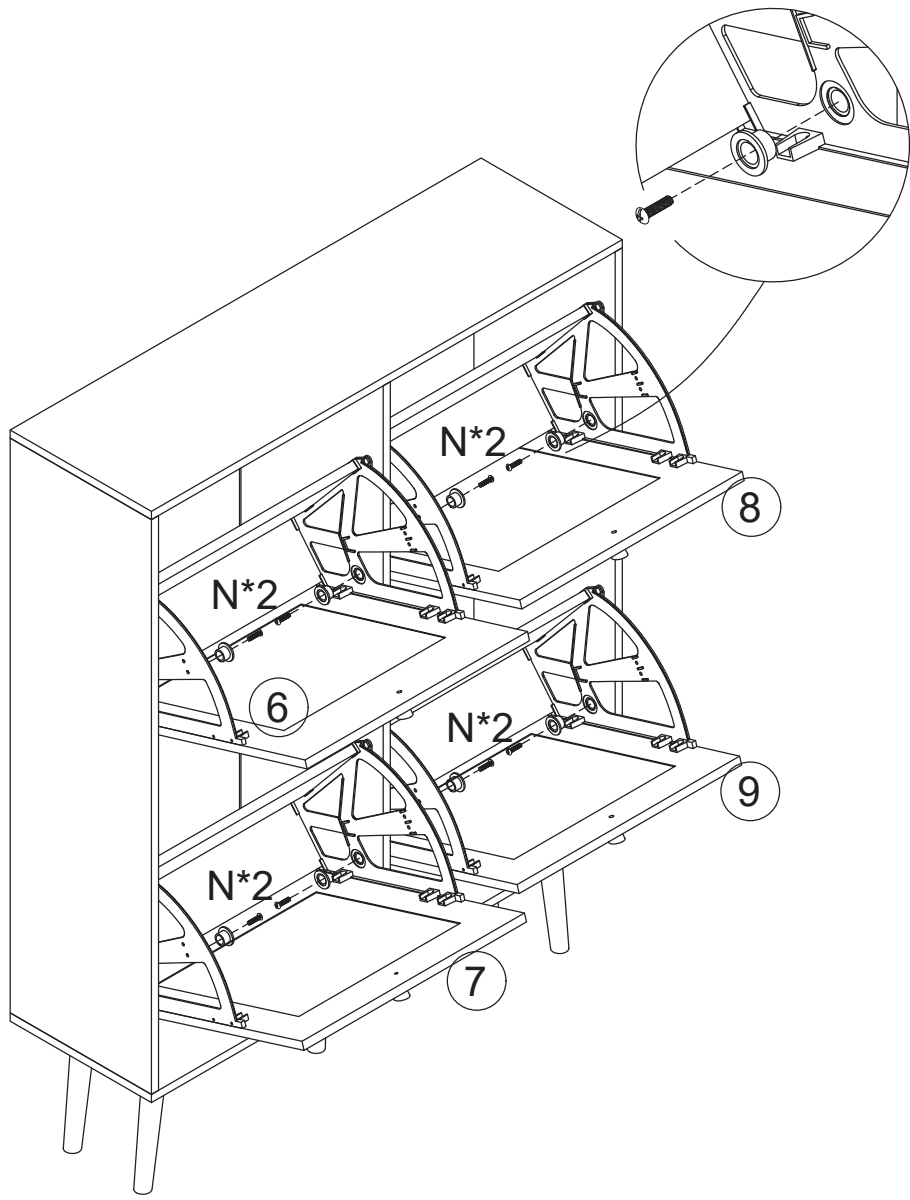

12

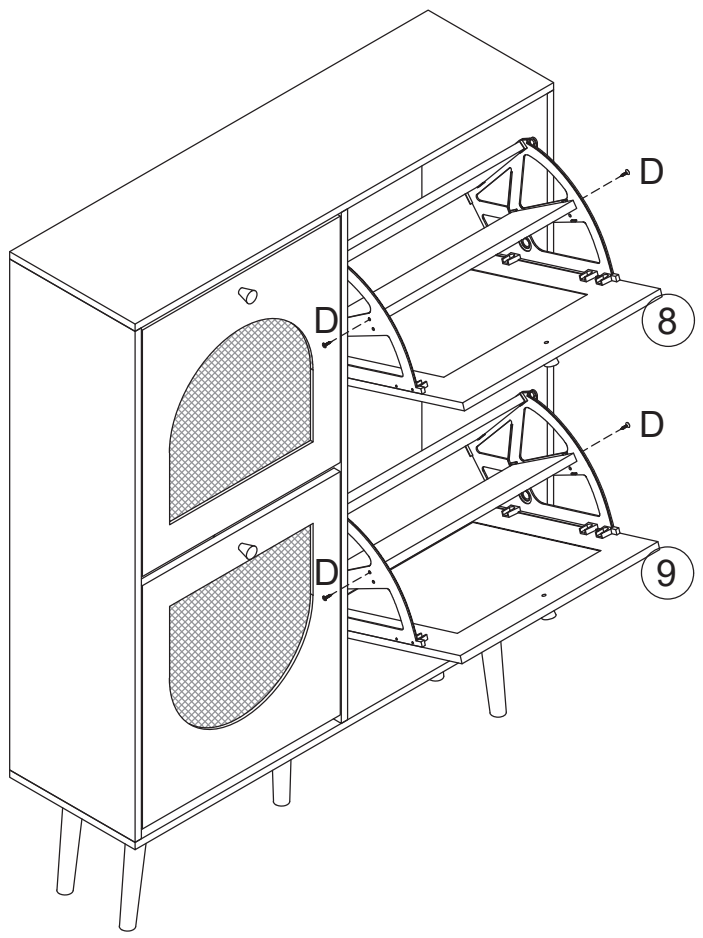
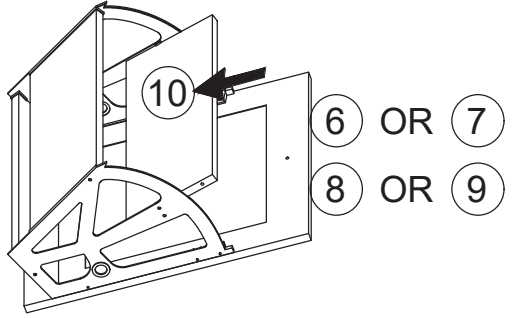

D	x4
	
4x12mm	

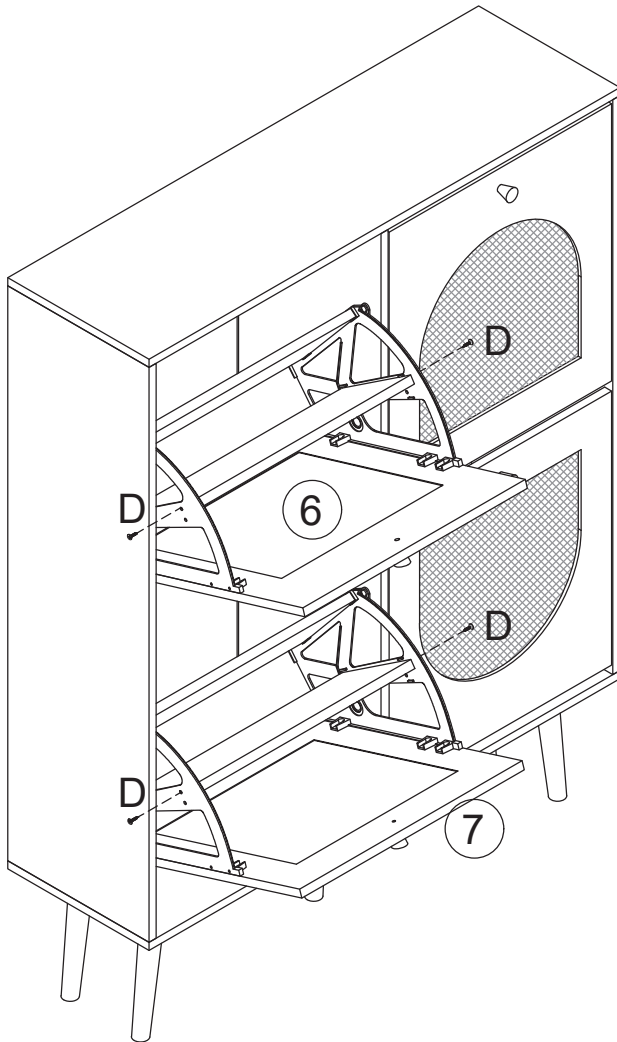

13

D	x4
	
4x12mm	



P	x2
	

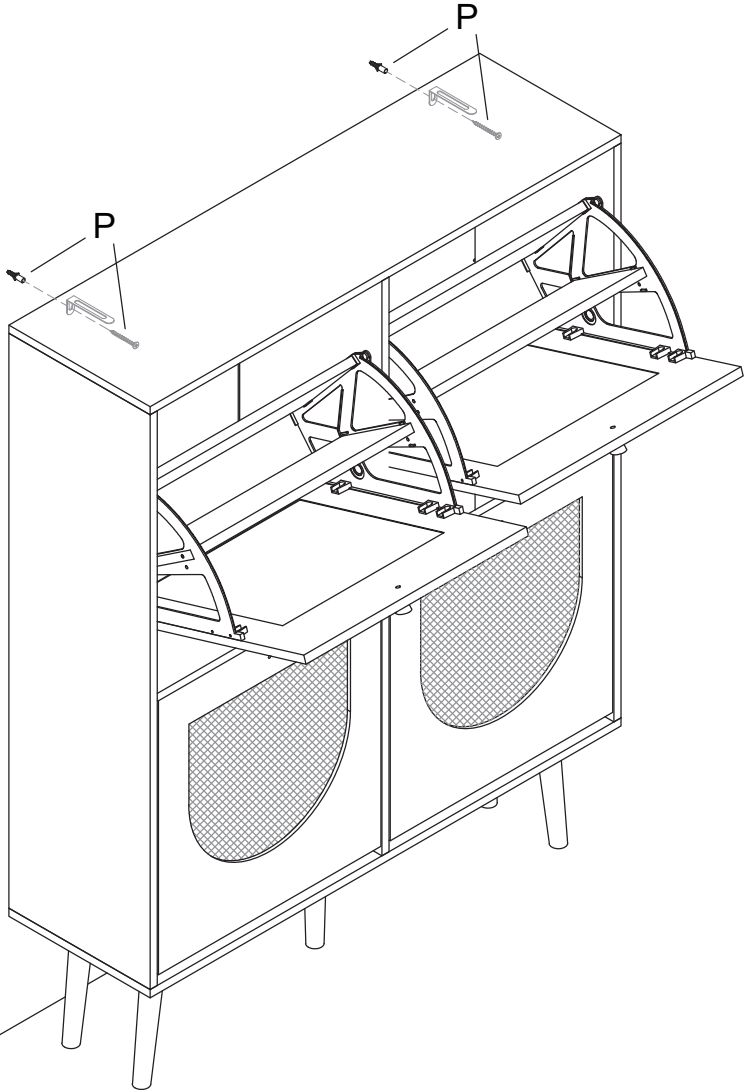

# Warranty/Garantie

The limited warranty covering the materials and the craftsmanship under normal use and service conditions takes effect from the purchase date (on the invoice). We provide:

2-year warranty

## REMINDER

1. Please note that the order purchase proof (order number or shipping information on the shipping carton) is the only valid evidence to claim for warranty. In the event that you failed to access your order information online, we strongly advise you to keep the original packaging and shipping carton(s).
2. To get what you need as soon as possible, we strongly suggest you provide all of the following information **at your first inquiry**:
  - Order number
  - Part number
  - Quantity required for each part
  - Pictures (or video clips, if applicable)

## Safety Warnings

Warning! Prevent tipping: Always secure this cabinet to the wall.

Warning! Do not overload Maximum load capacity.

Warning! Stable placement: Place the cabinet on a level and stable floor.

Warning! No climbing: Do not use the cabinet as a step ladder or a chair.

Warning! Mind fingers: Be careful when opening and closing doors/drawers.

Warning! Child safety: Children should be supervised. Do not play near the doors.

Warning! Regular inspection: Check fixtures and fittings regularly to ensure they are secure.

## Sicherheitswarnungen

Warnung! Umkippen verhindern: Schränke immer an der Wand befestigen.

Warnung! Nicht überladen Maximale Traglast.

Warnung! Stabiler Stand: Schrank auf ebenem und stabilem Untergrund aufstellen.

Warnung! Nicht klettern: Nicht als Leiter oder Hocker benutzen.

Warnung! Vorsicht, Quetschgefahr! Vorsicht beim Öffnen und Schließen der Türen/-Schubladen.

Warnung! Kindersicherheit: Kinder sollten beaufsichtigt werden. Nicht in der Nähe der Türen spielen.

Warnung! Regelmäßige Prüfung: Befestigungen und Verbindungen regelmäßig auf festen Sitz überprüfen.

## Avertissements de Sécurité

Attention ! Risque de basculement : Fixez toujours l'armoire au mur.

Attention ! Ne pas surcharger Charge maximale.

Attention ! Placement stable : Placez l'armoire sur un sol plat et stable.

Attention ! Ne pas grimper : Ne pas utiliser l'armoire comme escabeau ou chaise.

Attention ! Attention aux doigts : Soyez prudent lors de l'ouverture et de la fermeture des portes/tiroirs.

Attention ! Sécurité des enfants : Les enfants doivent être surveillés. Ne pas jouer près des portes.

Attention ! Vérification régulière : Vérifiez régulièrement que les fixations et les assemblages sont bien serrés.

## Avvertenze di Sicurezza

Attenzione! Prevenire il ribaltamento: Fissare sempre il mobile alla parete.

Attenzione! Non sovraccaricare Portata massima.

Attenzione! Posizionamento stabile: Collocare il mobile su una superficie piana e stabile.

Attenzione! Non arrampicarsi: Non utilizzare il mobile come scaletta o sedia.

Attenzione! Attenzione alle dita: Prestare attenzione all'apertura e alla chiusura di ante/cassetti.

Attenzione! Sicurezza bambini: I bambini devono essere sorvegliati. Non giocare vicino alle ante.

Attenzione! Ispezione periodica: Controllare regolarmente che le connessioni e le fissazioni siano sicure.

### Advertencias de Seguridad

¡Advertencia! Evite el vuelco: Sujete siempre el armario a la pared.

¡Advertencia! No sobrecargar Carga máxima.

¡Advertencia! Colocación estable: Coloque el armario sobre una superficie plana y estable.

¡Advertencia! No trepar: No utilice el armario como escalera o silla.

¡Advertencia! Cuidado con los dedos: Tenga cuidado al abrir y cerrar puertas/cajones.

¡Advertencia! Seguridad infantil: Los niños deben ser supervisados. No jugar near de las puertas.

¡Advertencia! Inspección regular: Compruebe regularmente que los conectores y las fijaciones estén seguros.

### VeiligheidsWaarschuwingen

Waarschuwing! Kantelgevaar: Bevestig de kast altijd aan de wand.

Waarschuwing! Niet overbelasten Maximale belasting.

Waarschuwing! Stabiele plaatsing: Plaats de kast op een vlakke en stabiele ondergrond.

Waarschuwing! Niet klimmen: Niet gebruiken als ladder of stoel.

Waarschuwing! Pas op voor vingers: Wees voorzichtig bij het openen en sluiten van deuren/lades.

Waarschuwing! Kinderveiligheid: Kinderen moeten onder toezicht worden gebruikt. Niet spelen near de deuren.

Waarschuwing! Regelmatige controle: Controleer regularly of bevestigingen en verbindingen stevig zijn.

## Säkerhetsvarningar

Varning! Förhindra välting: Fäst alltid skåpet i väggen.

Varning! Överlasta inte Maximal belastning.

Varning! Stabil placering: Placera skåpet på ett plant och stabilt golv.

Varning! Klättra inte: Använd inte skåpet som stege eller stol.

Varning! Akta fingrarna: Var försiktig när du öppnar och stänger dörrar/lådor.

Varning! Barnsäkerhet: Barn bör användas under uppsikt. Lek inte near dörrarna.

Varning! Regelbunden kontroll: Kontrollera regelbundet att fästanordningarna och förbanden sitter fast.

## Ostrzeżenia Bezpieczeństwa

Ostrożnie! Zapobiegaj przewróceniu: Zawsze mocuj szafę do ściany.

Ostrożnie! Nie przeciążać Maksymalne obciążenie.

Ostrożnie! Stabilne ustawienie: Ustaw szafę na równej i stabilnej podłodze.

Ostrożnie! Nie wspinać się: Nie używaj szafy jako drabiny lub krzesła.

Ostrożnie! Uwaga na palce: Zachowaj ostrożność podczas otwierania i zamykania drzwi/szuflad.

Ostrożnie! Bezpieczeństwo dzieci: Dzieci powinny być nadzorowane. Nie baw się near drzwiami.

Ostrożnie! Regularna kontrola: Regularnie sprawdzaj, czy połączenia i ele