

Assembly Instructions

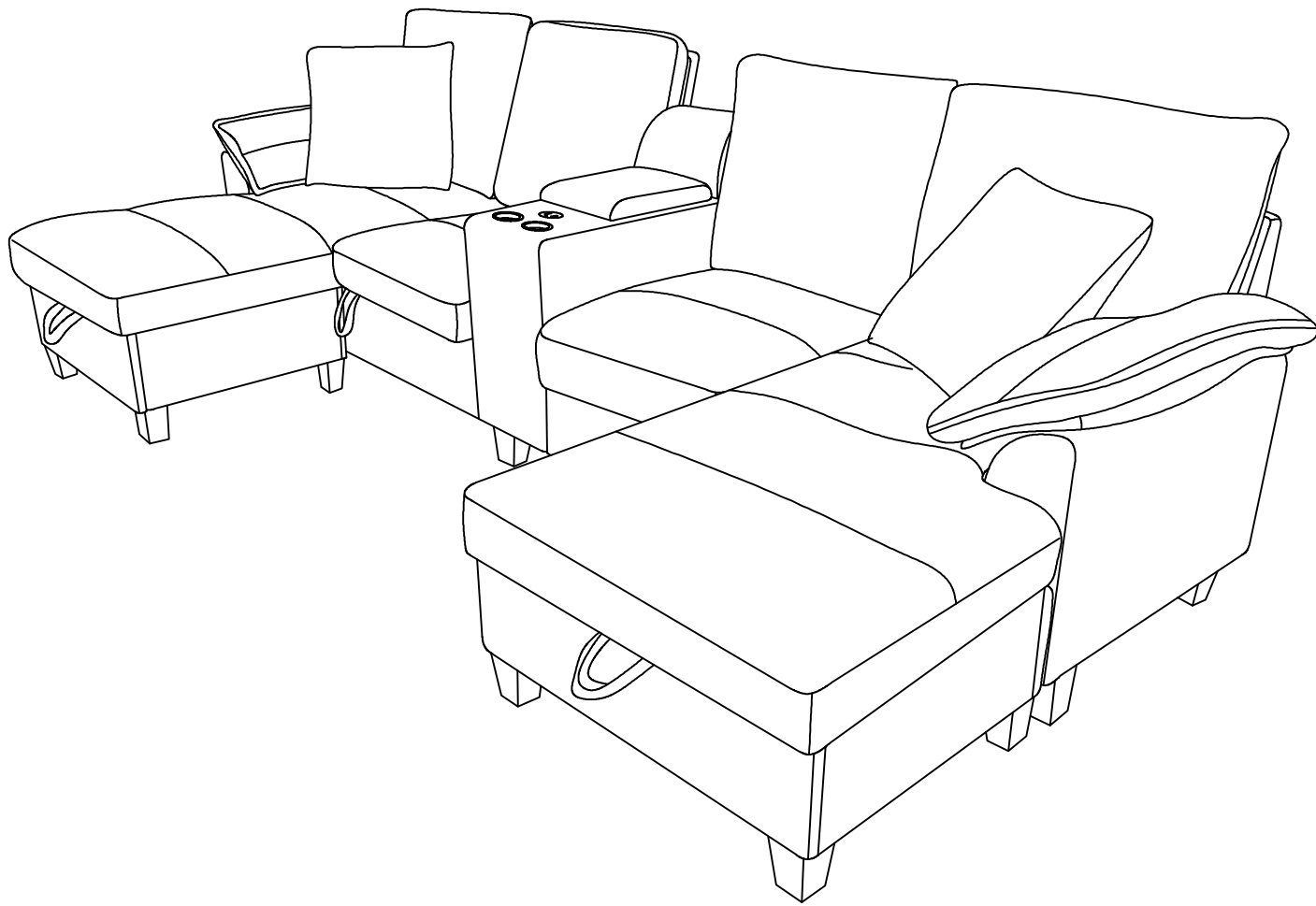

IMPORTANT NOTE

**Place all parts on a lean and smooth surface such as a rug or carpet to avoid the parts from being scratched.

**Before you begin, please review the assembly instruction step by step.



**Return & Warranty Policy:

-We strive to offer the highest quality products. We also provide positive solutions with replacements or refund if needed.





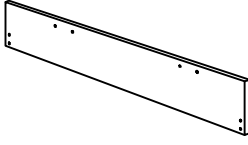
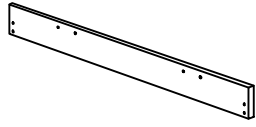

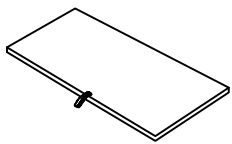
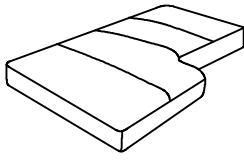
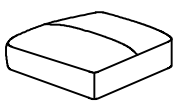
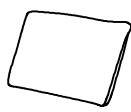
-If the item is damaged or defective, please take photos to show the problem and email to the seller.

-Please do not return back the product before contact the seller.

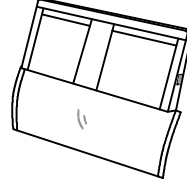
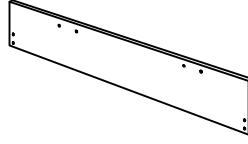
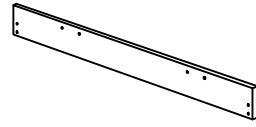

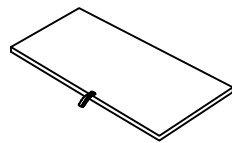

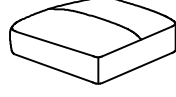
PART LIST CARTON 1

Part No.	Part Image	Part mane	QTY	Part No.	Part Image	Part mane	QTY
L		Backrest	x1	H		Sofa front board	X1
I		Sofa back board	x1	K		Ottoman left and right board	X2
G		Sofa seat board	x1	Q		Seat Cushion	x1
P		Seat Cushion	x1	M		Back Cushion	x1



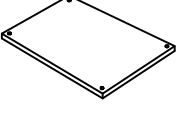
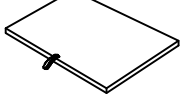
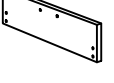



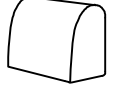

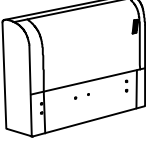
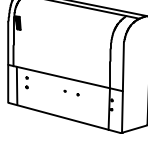
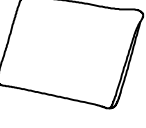

PART LIST CARTON 2

Part No.	Part Image	Part mane	QTY	Part No.	Part Image	Part mane	QTY
L		Backrest	x1	H		Sofa front board	X1
I		Sofa back board	x1	K		Ottoman left and right board	X2
G		Sofa seat board	x1	O		Seat Cushion	x1
P		Seat Cushion	x1	M		Back Cushion	x1

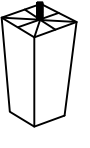
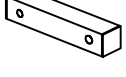
PART LIST CARTON 2

Part No.	Part Image	Part mane	QTY	Part No.	Part Image	Part mane	QTY
D		Console	x1	E		Ottoman base board	x2
F		Ottoman seat board	x2	J		Ottoman front and back board	x4
R		Left arm cushion	x1	S		Right arm cushion	x1
N		Throw pillow	x2	C		Back frame of console	x1

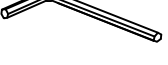
PART LIST CARTON 2

Part No.	Part Image	Part mane	QTY	Part No.	Part Image	Part mane	QTY
A		Left armrest	x1	B		Right armrest	x1
M		Back cushion	x2	T		Connecting Insert	x2
U		Angle code	x8	V		Angle code	x8
W		Leg	x14	X		Square tube	x20
Y1		Bolt	x64	Y2		Bolt	x40
Z1		Flat washer	x104	Z2		Allen Key	x1
Z3		Plug	x1				

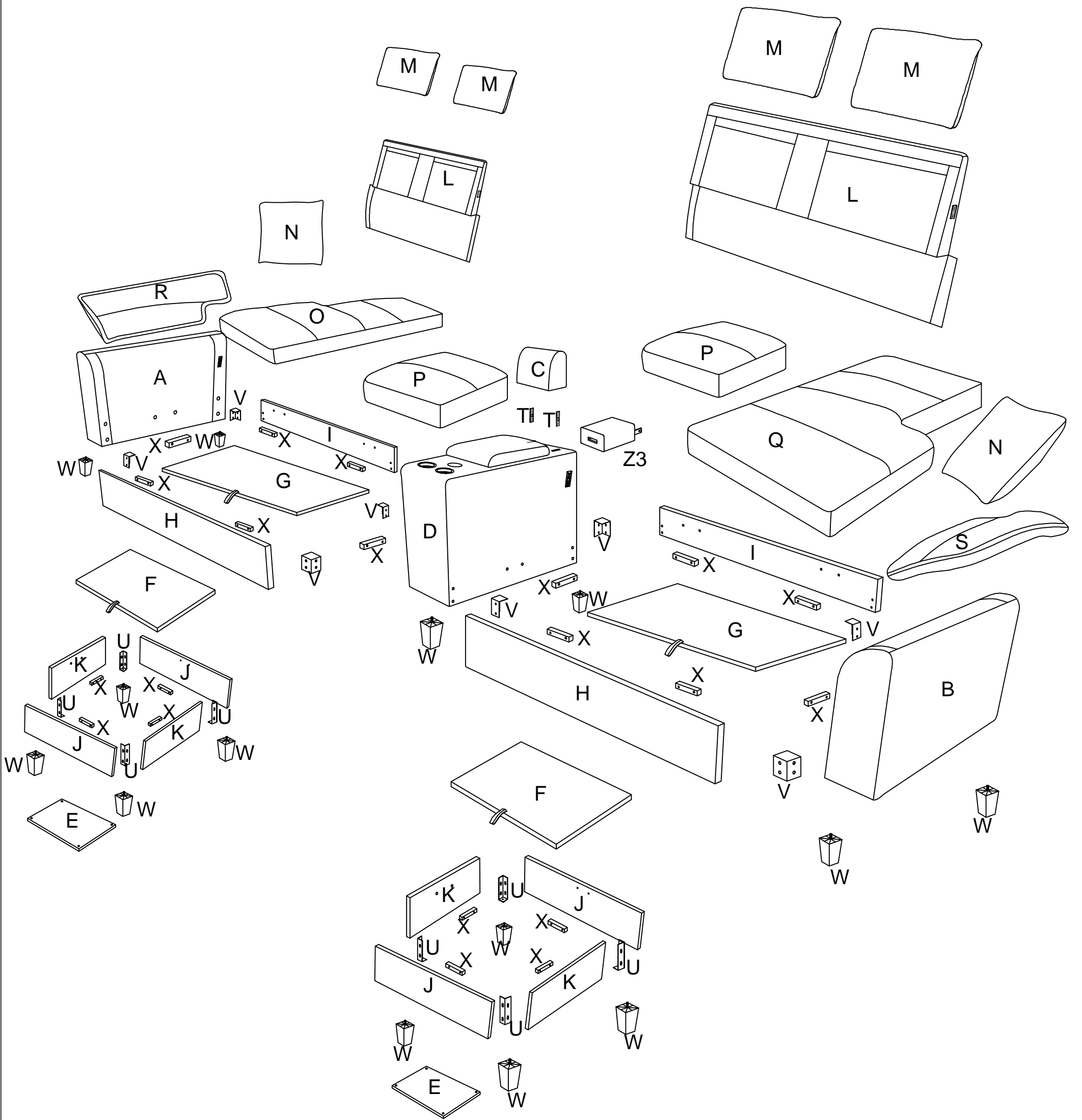

STEP 1

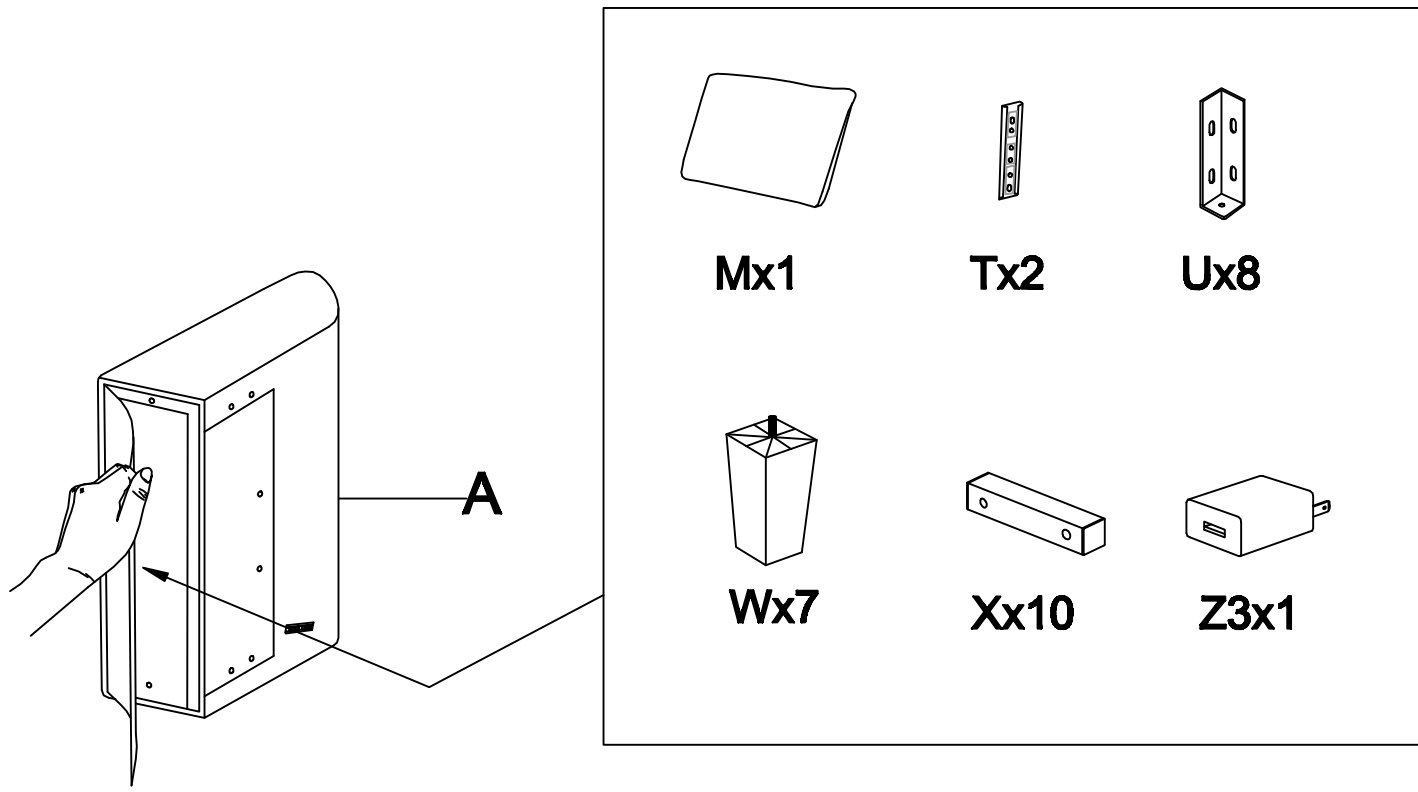

STEP 2

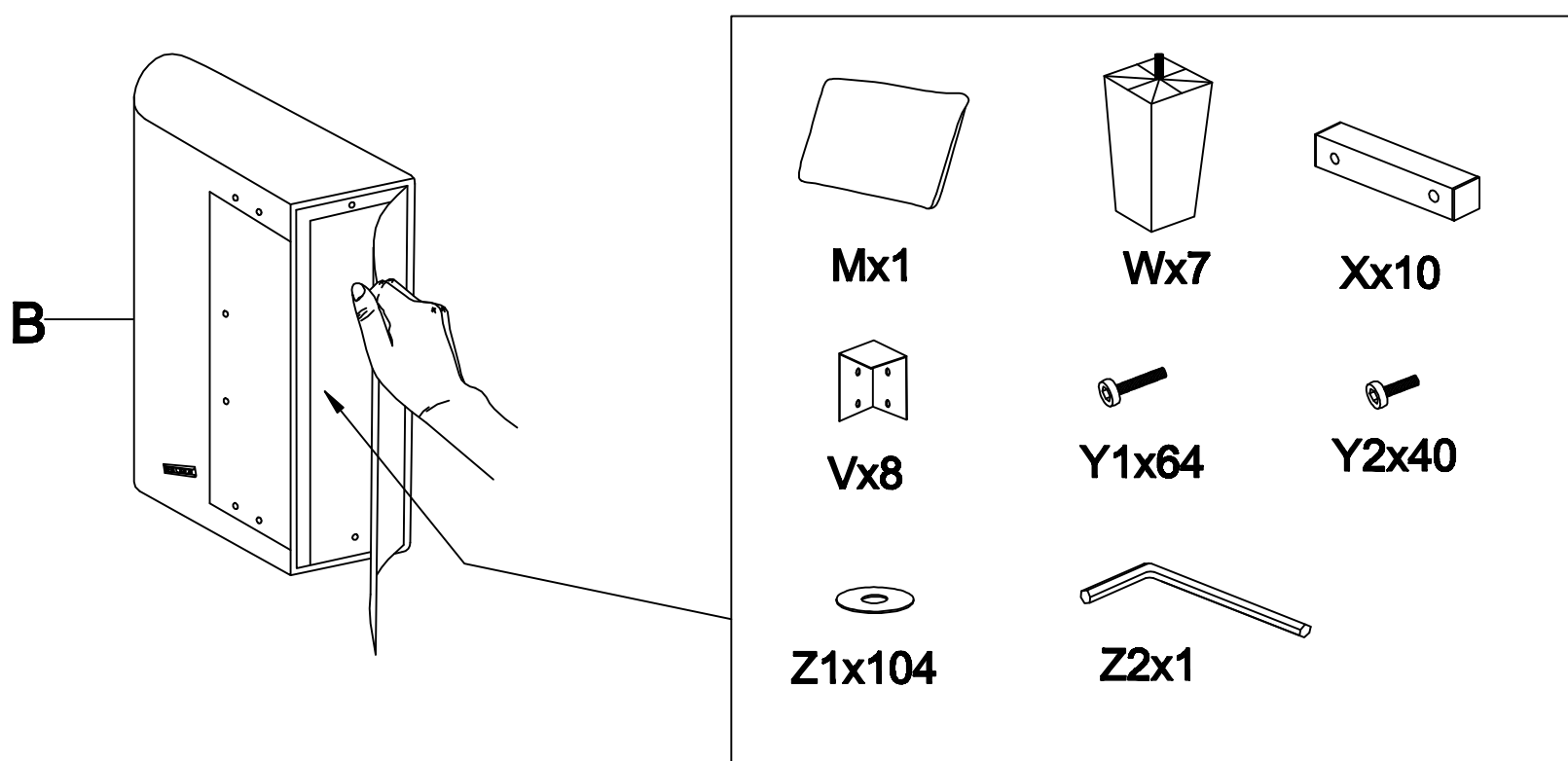

STEP 3

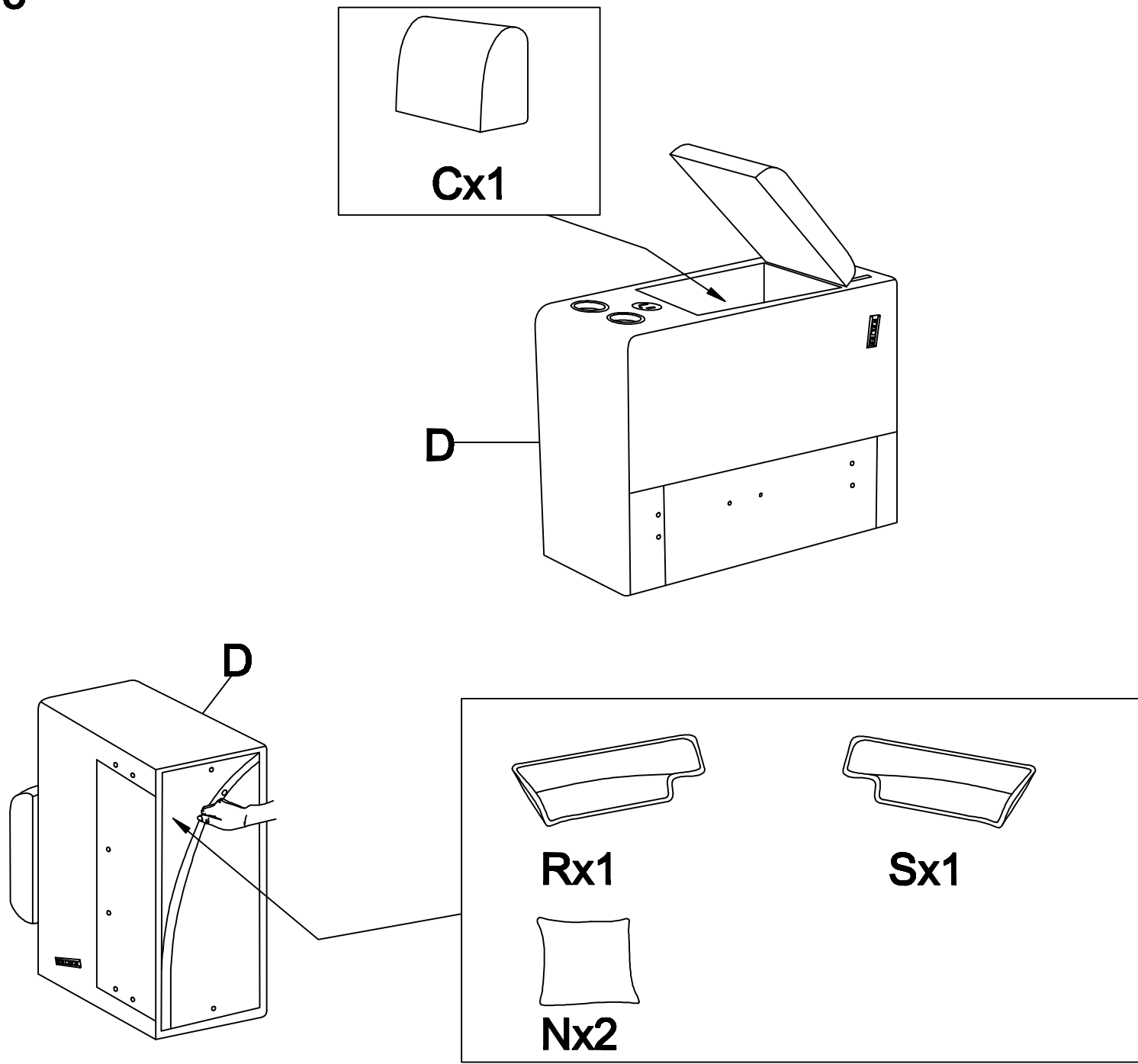

STEP 4

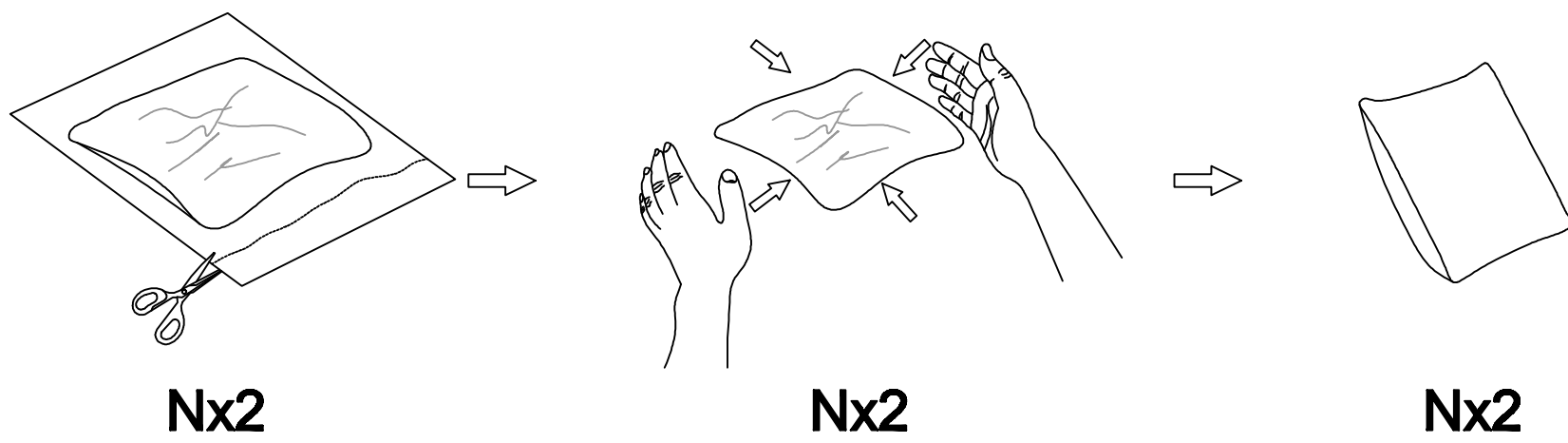

STEP 5

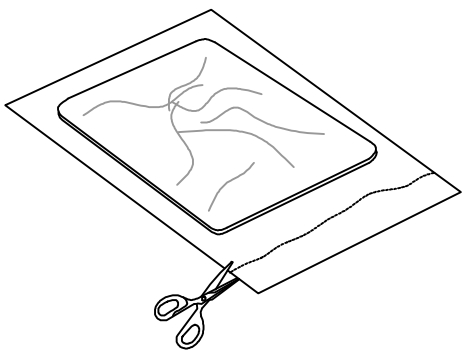

Mx4

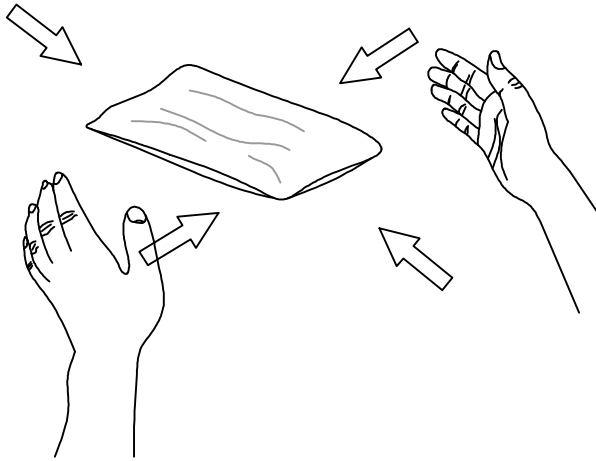
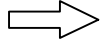

Mx4

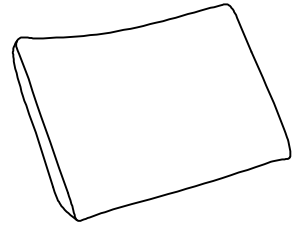
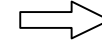

Mx4

STEP 6

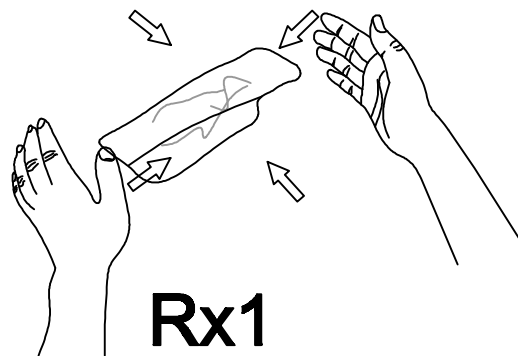
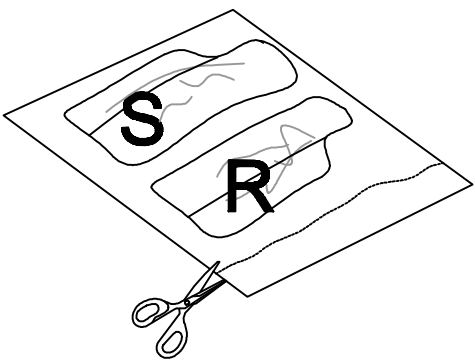

Rx1

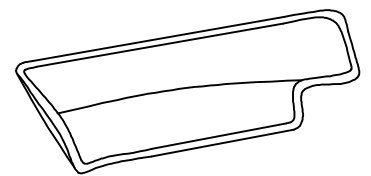

Rx1

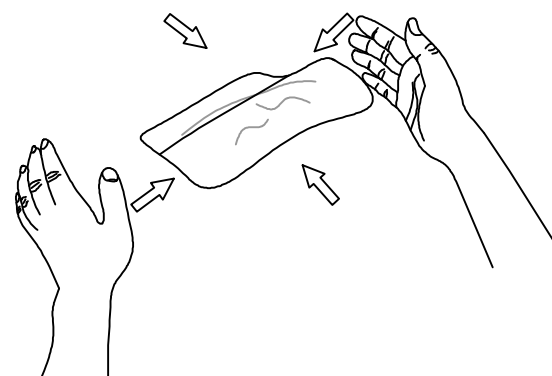

Sx1

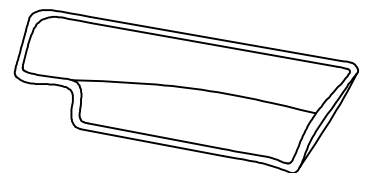

Sx1

STEP 7

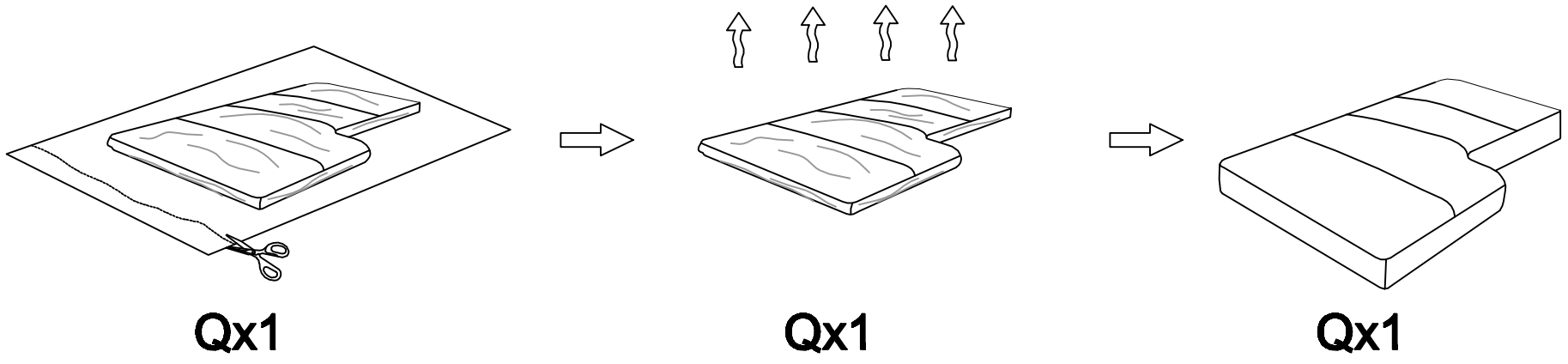

Please wait for 72 hours

STEP 8

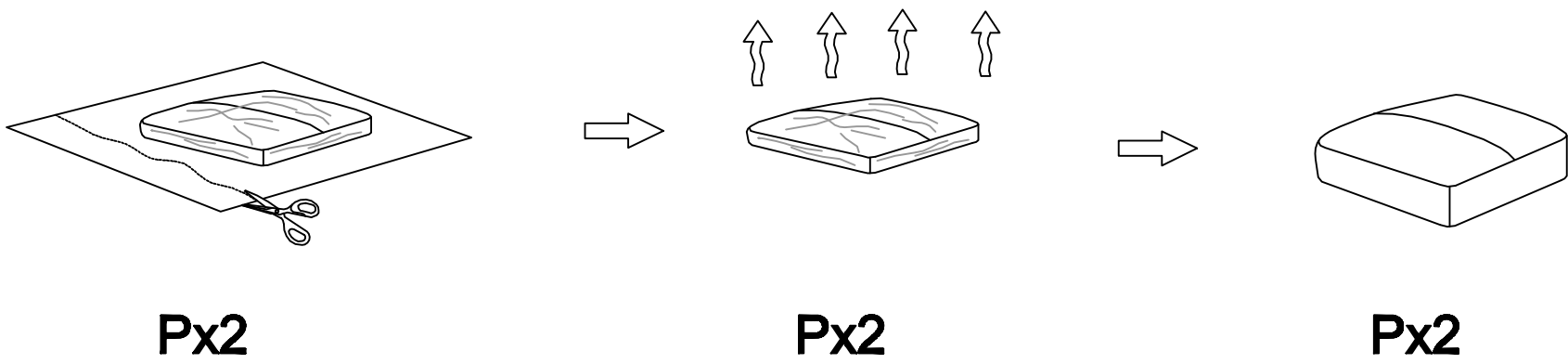

Please wait for 72 hours

STEP 9

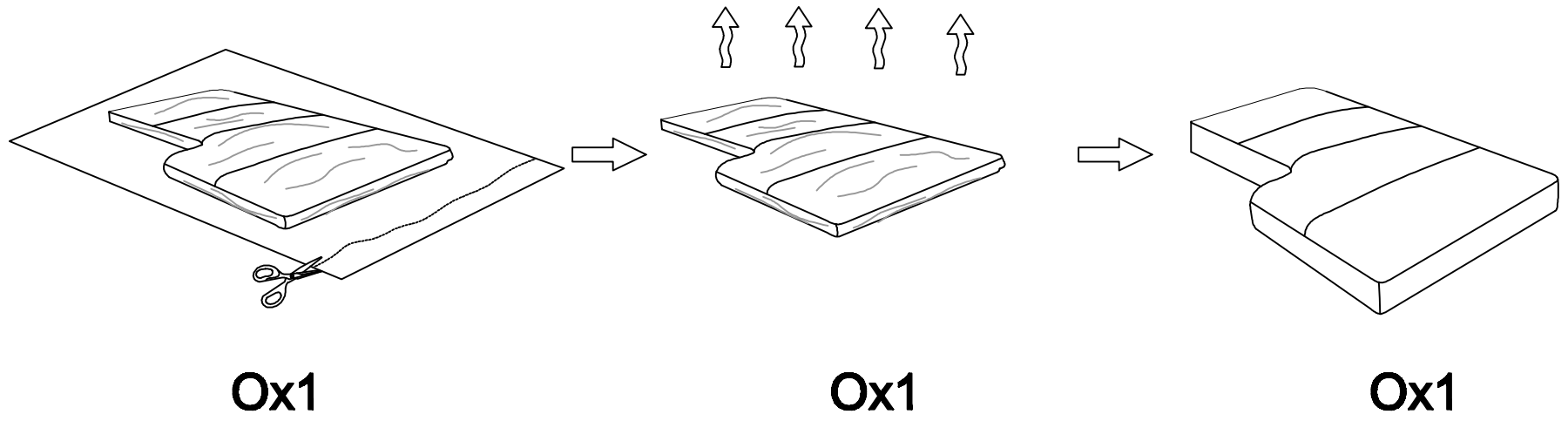

Please wait for 72 hours

STEP 10

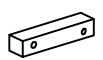
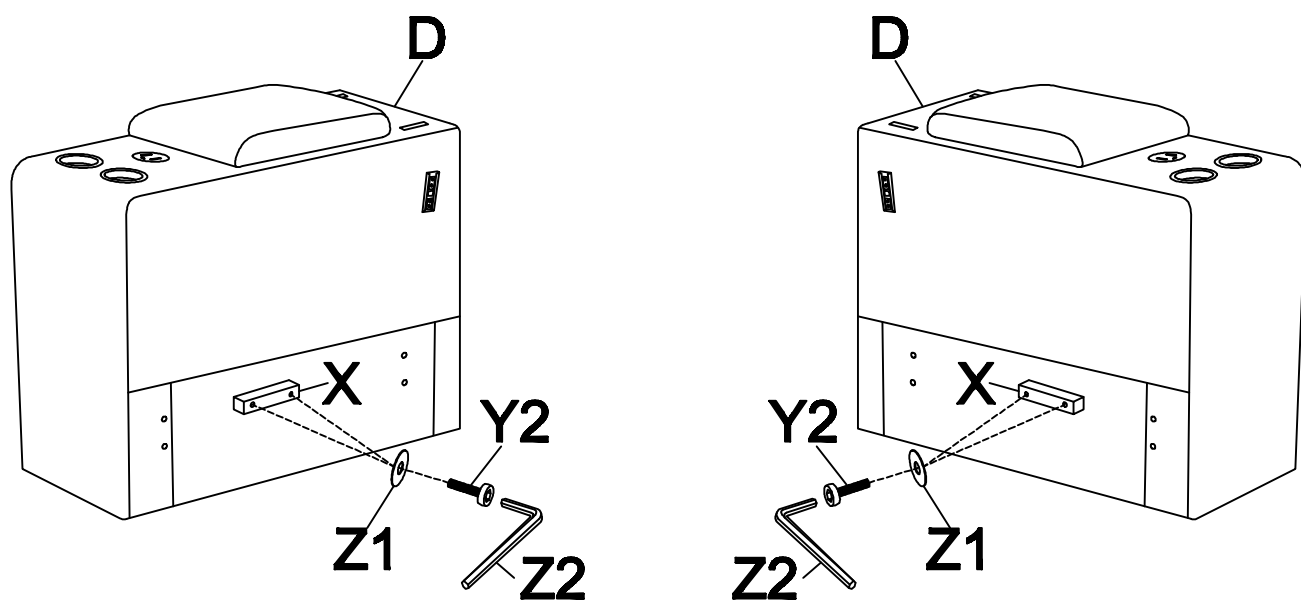

Xx2



Y2x4





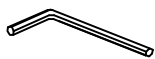

Z1x4

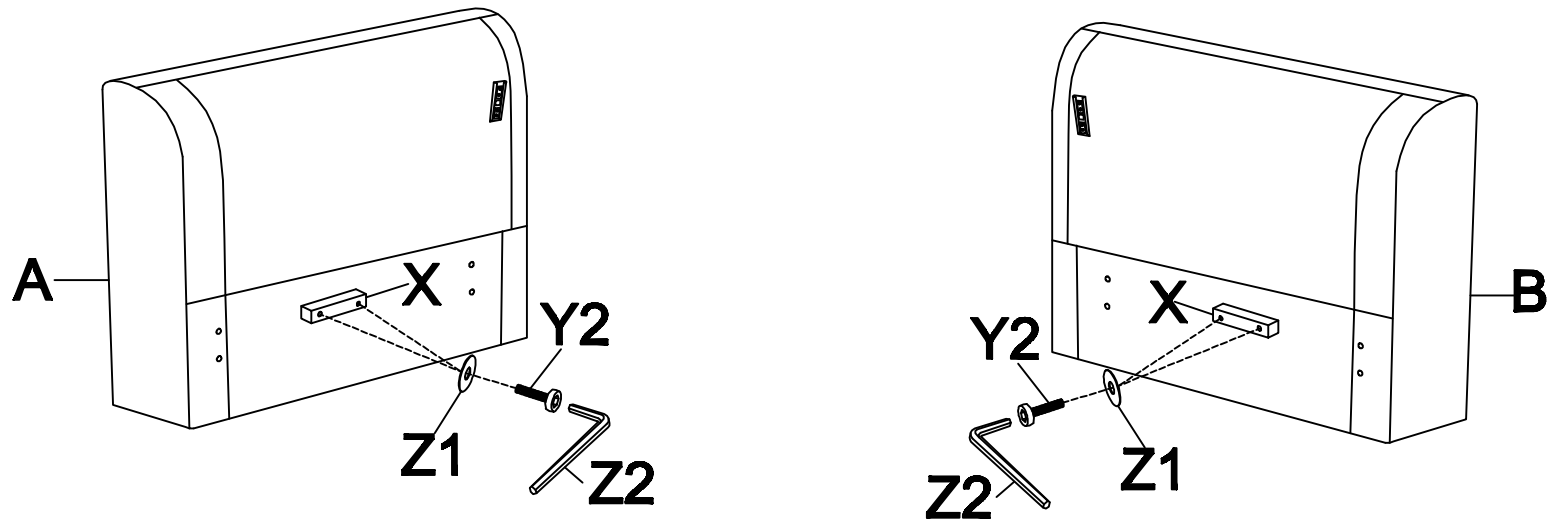

Z2x1



STEP 11

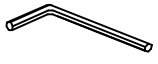

			
Xx2	Y2x4	Z1x4	Z2x1

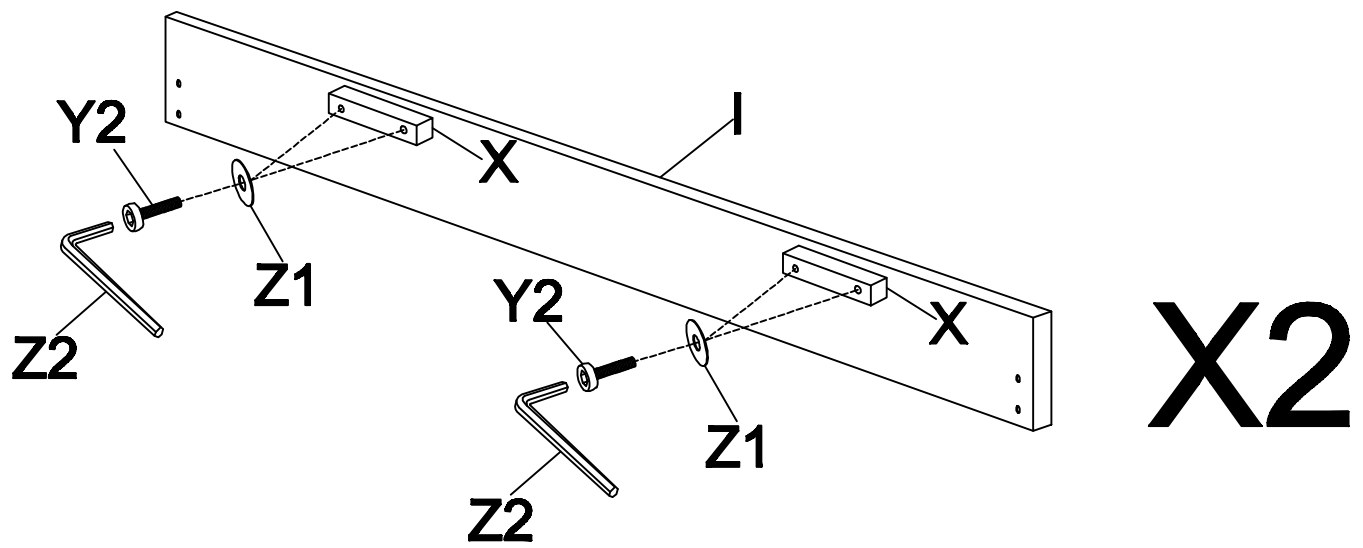

STEP 12

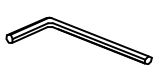

			
Xx4	Y2x8	Z1x8	Z2x1

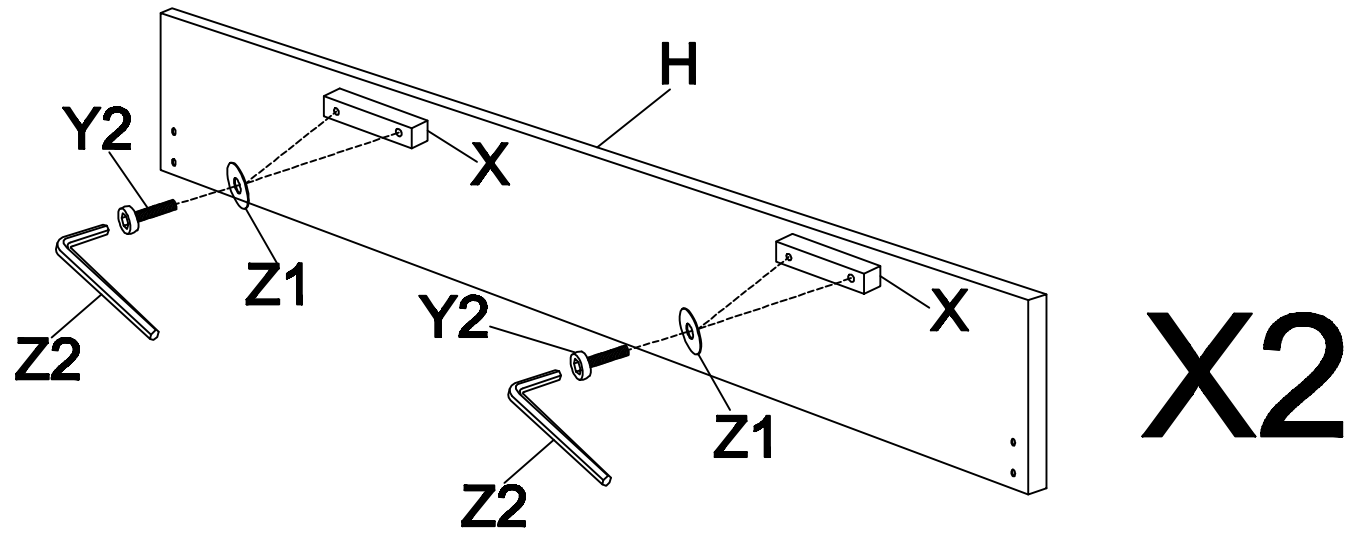

STEP 13

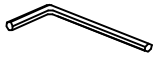

			
Xx4	Y2x8	Z1x8	Z2x1

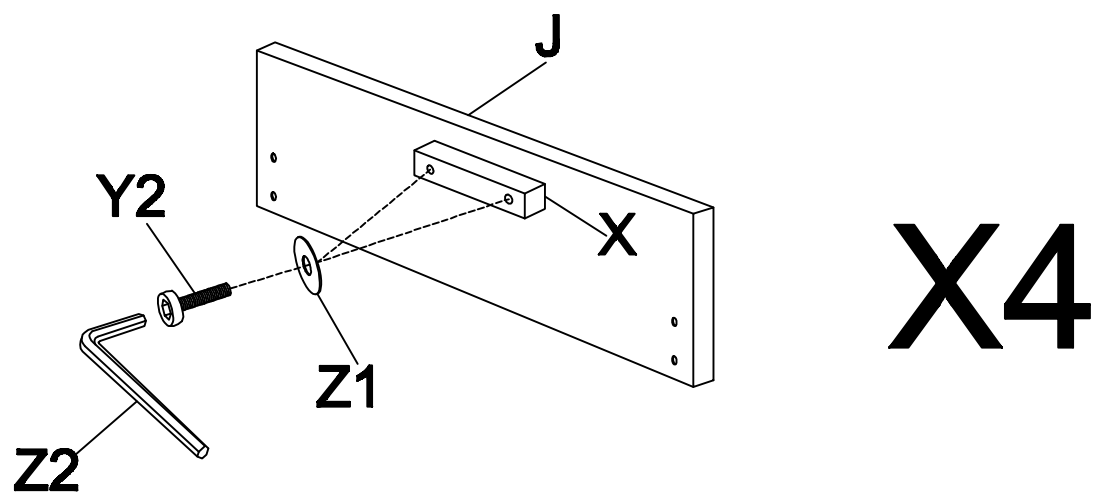

STEP 14

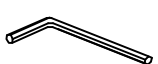

			
Xx4	Y2x8	Z1x8	Z2x1

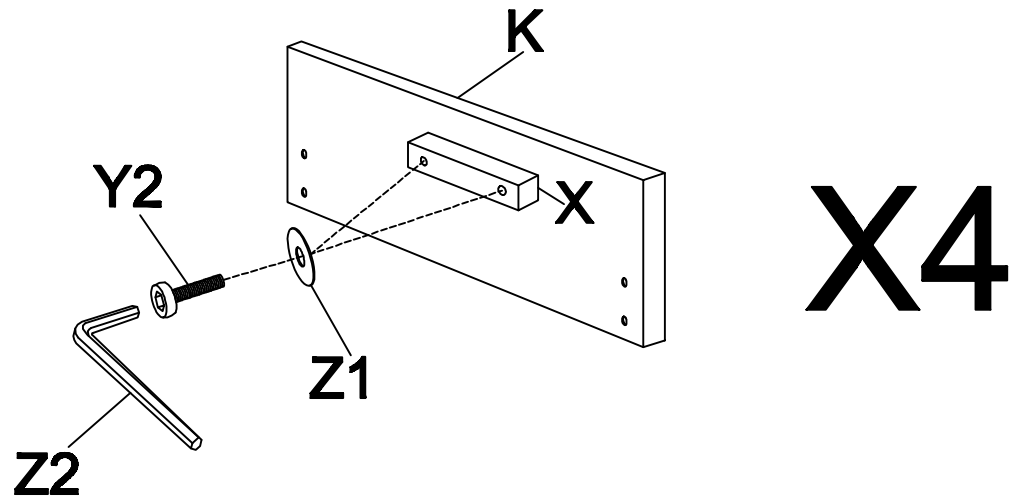

STEP 15

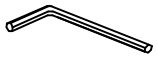

			
Xx4	Y2x8	Z1x8	Z2x1

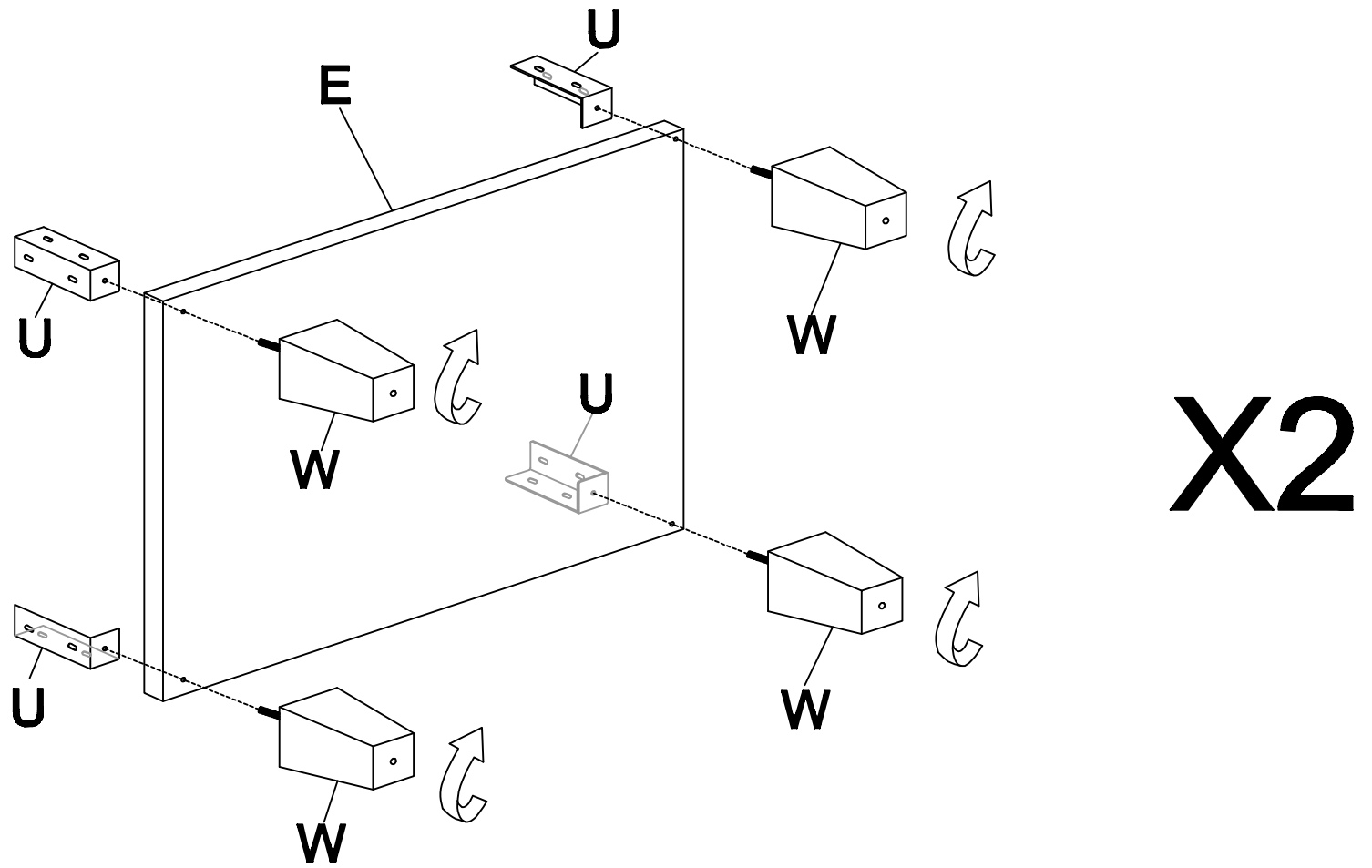

STEP 16

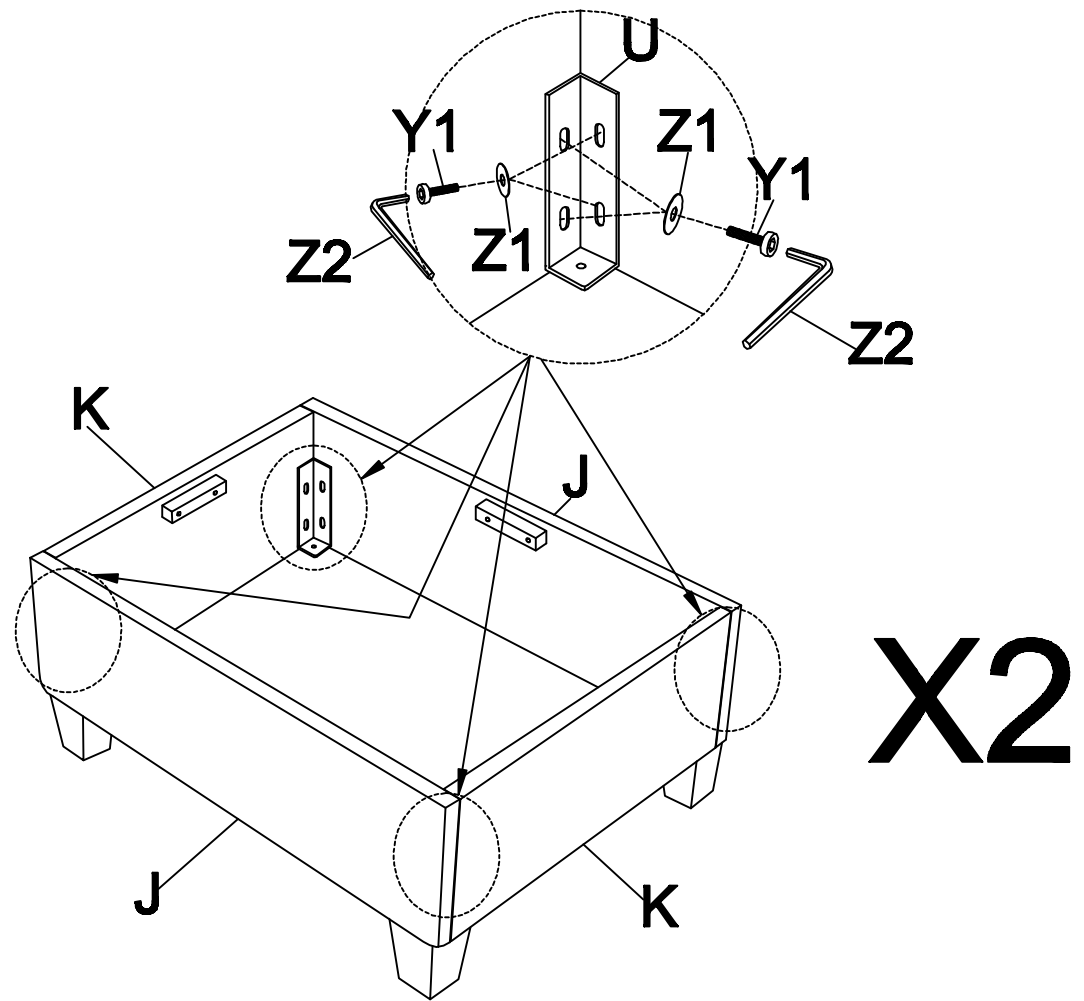

	
Wx8	Ux8

STEP 17

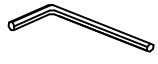

		
Y1x16	Z1x16	Z2x1

STEP 18

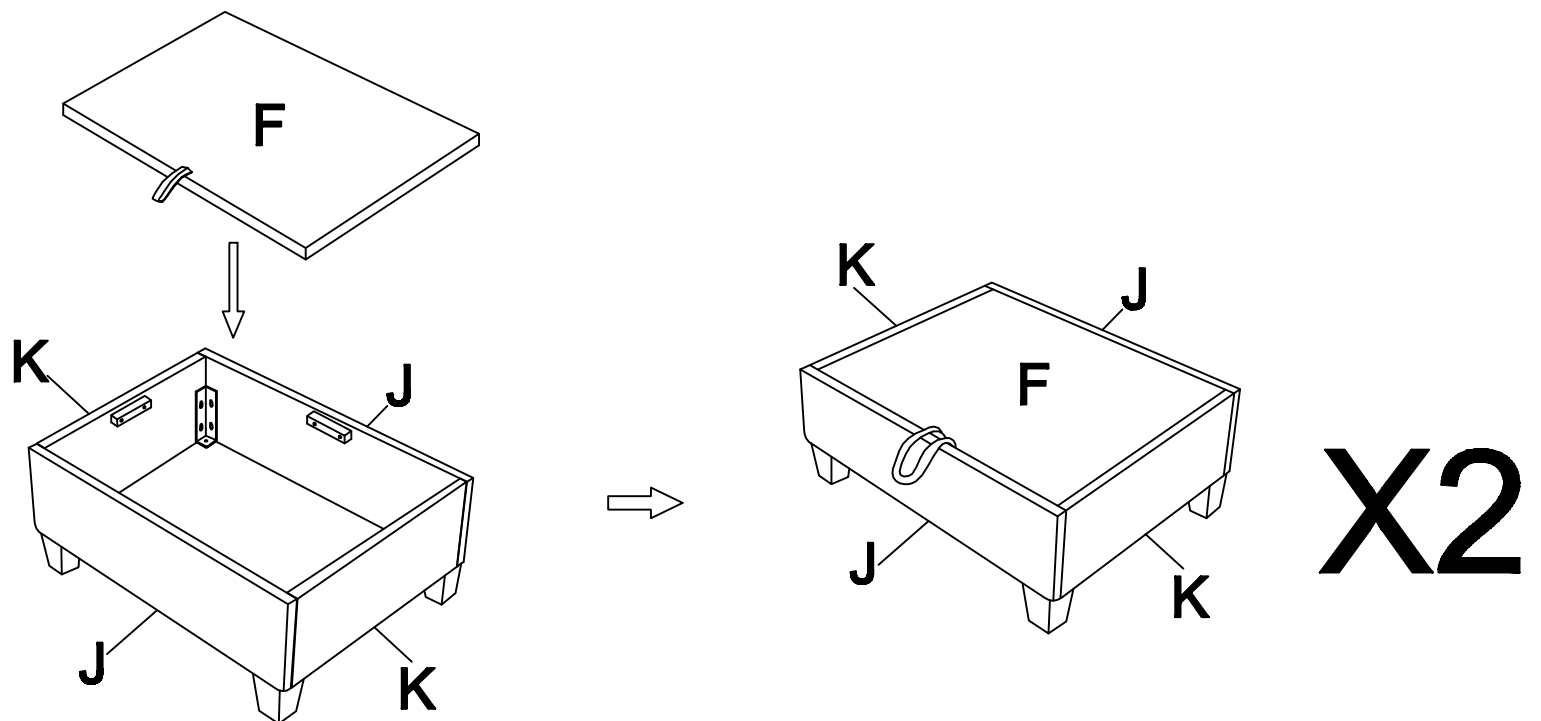

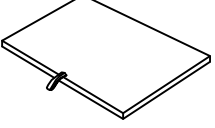

Fx2

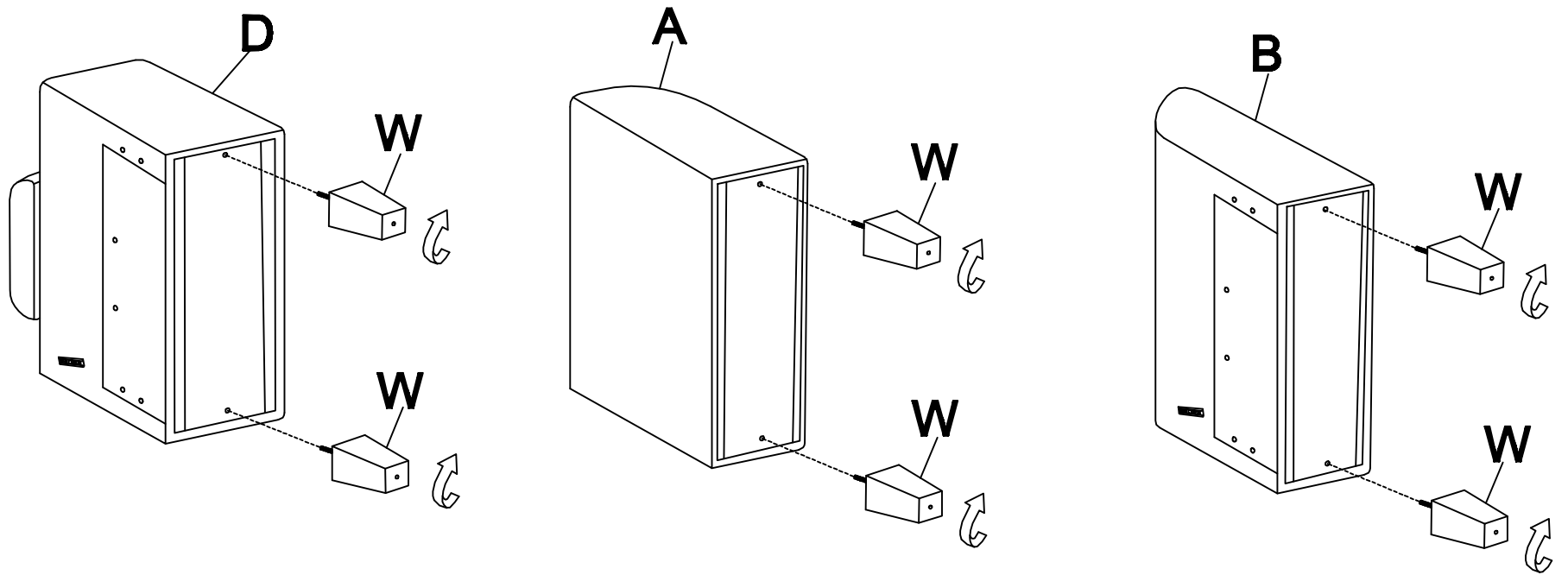
STEP 19

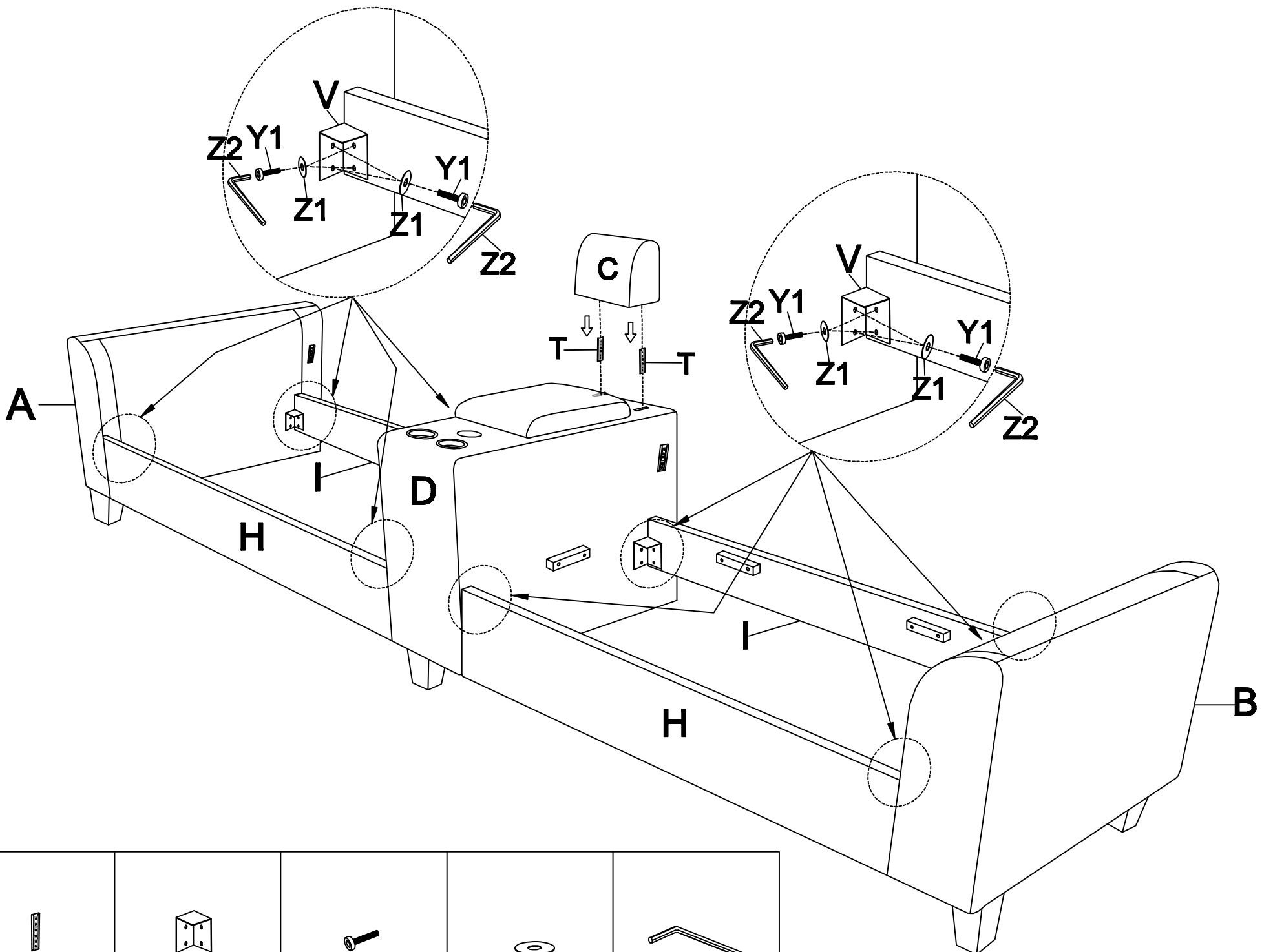

Wx6

STEP 20



Tx2



Vx8



Y1x32



Z1x32

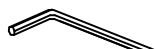

Z2x1

STEP 21

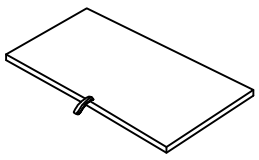
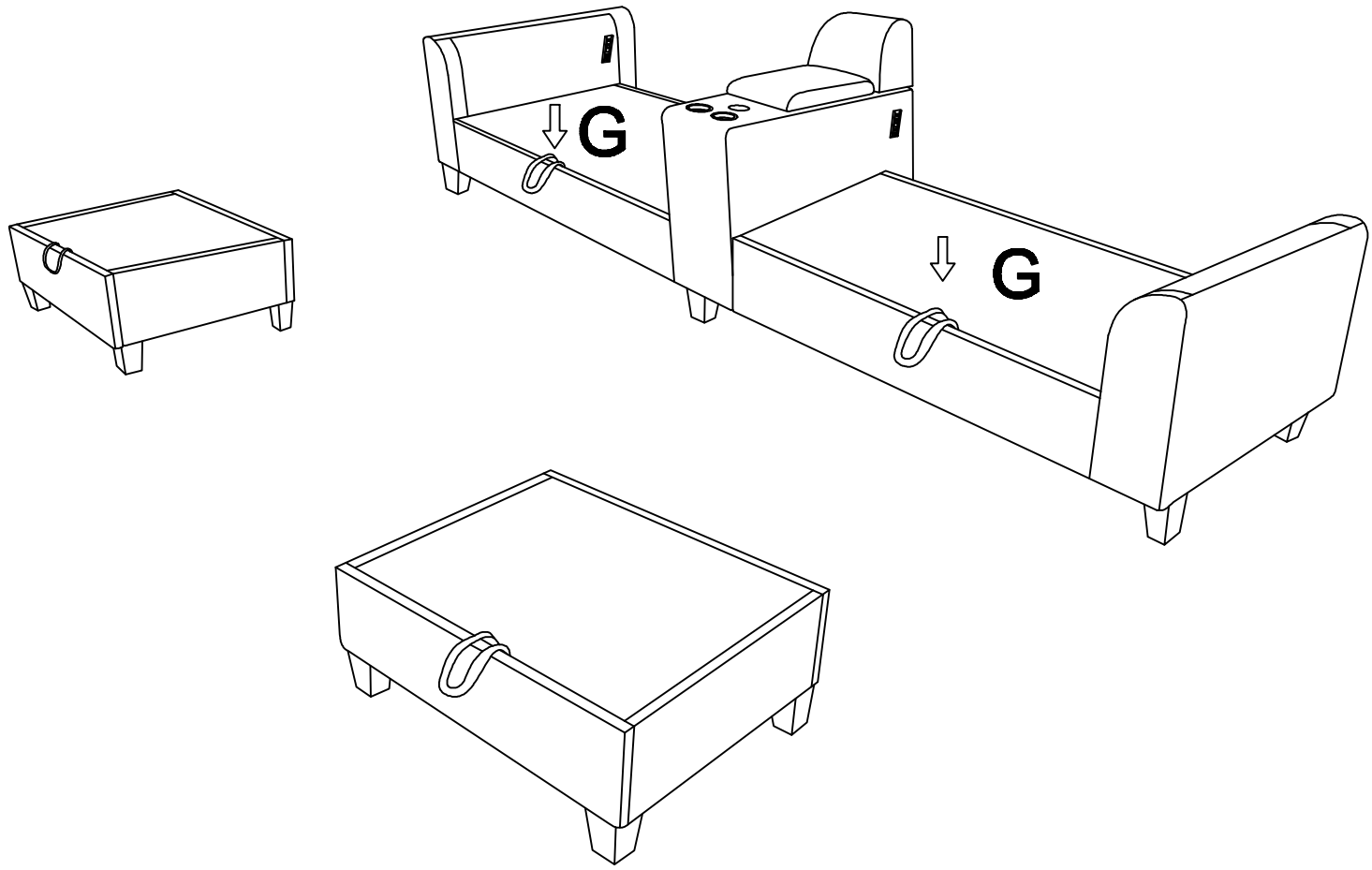

Gx2

STEP 22

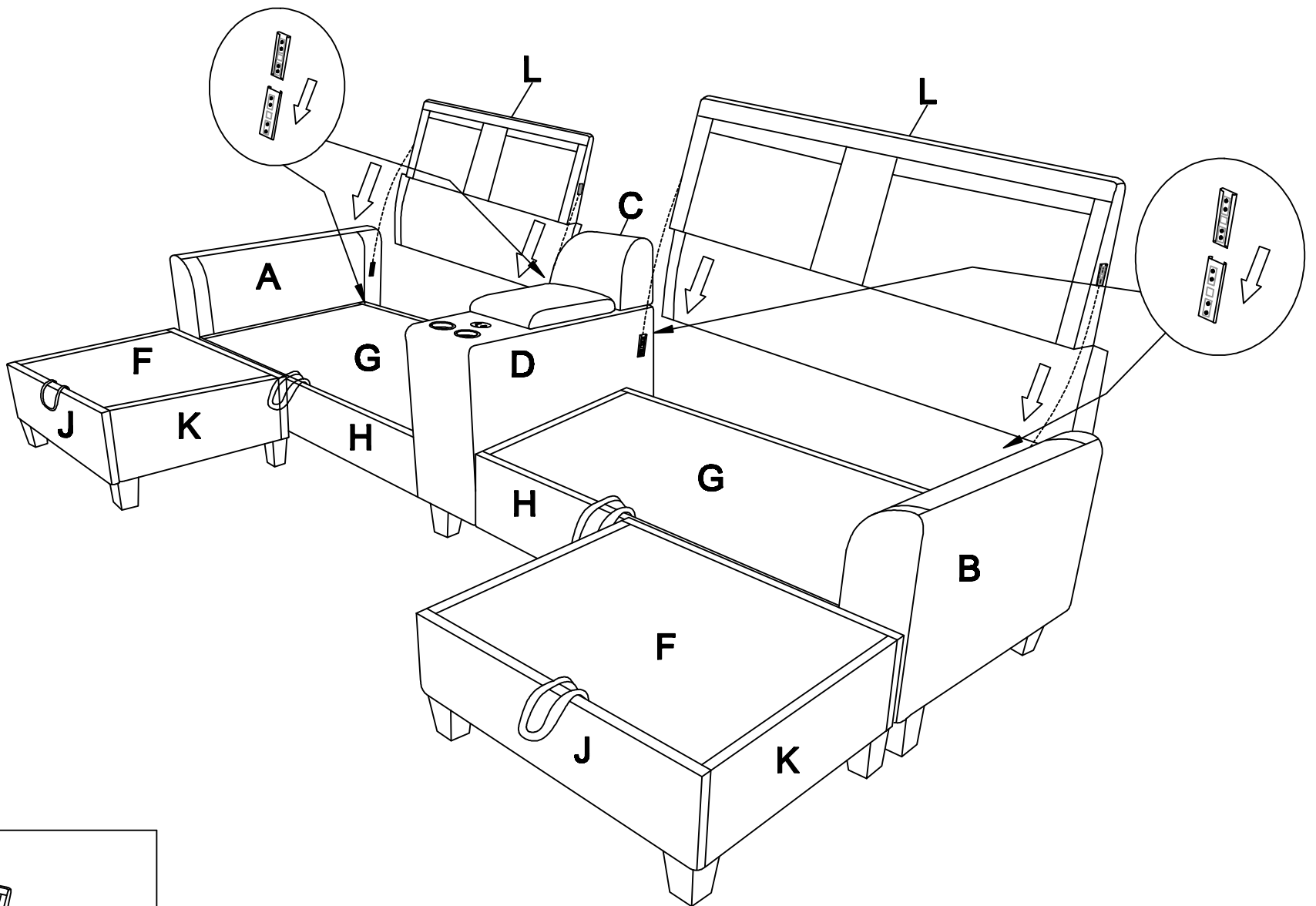

Lx2

STEP 23

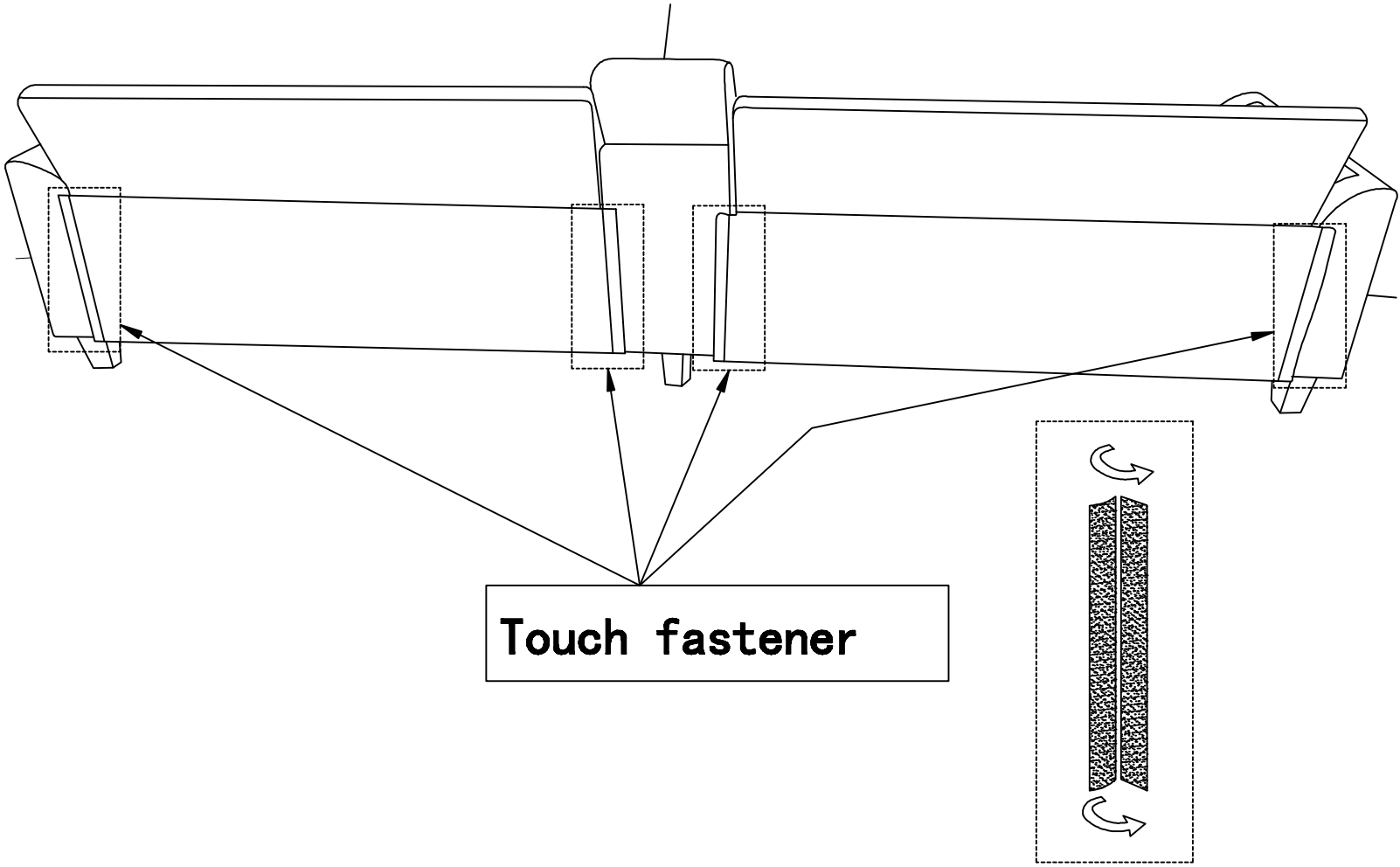

STEP 24

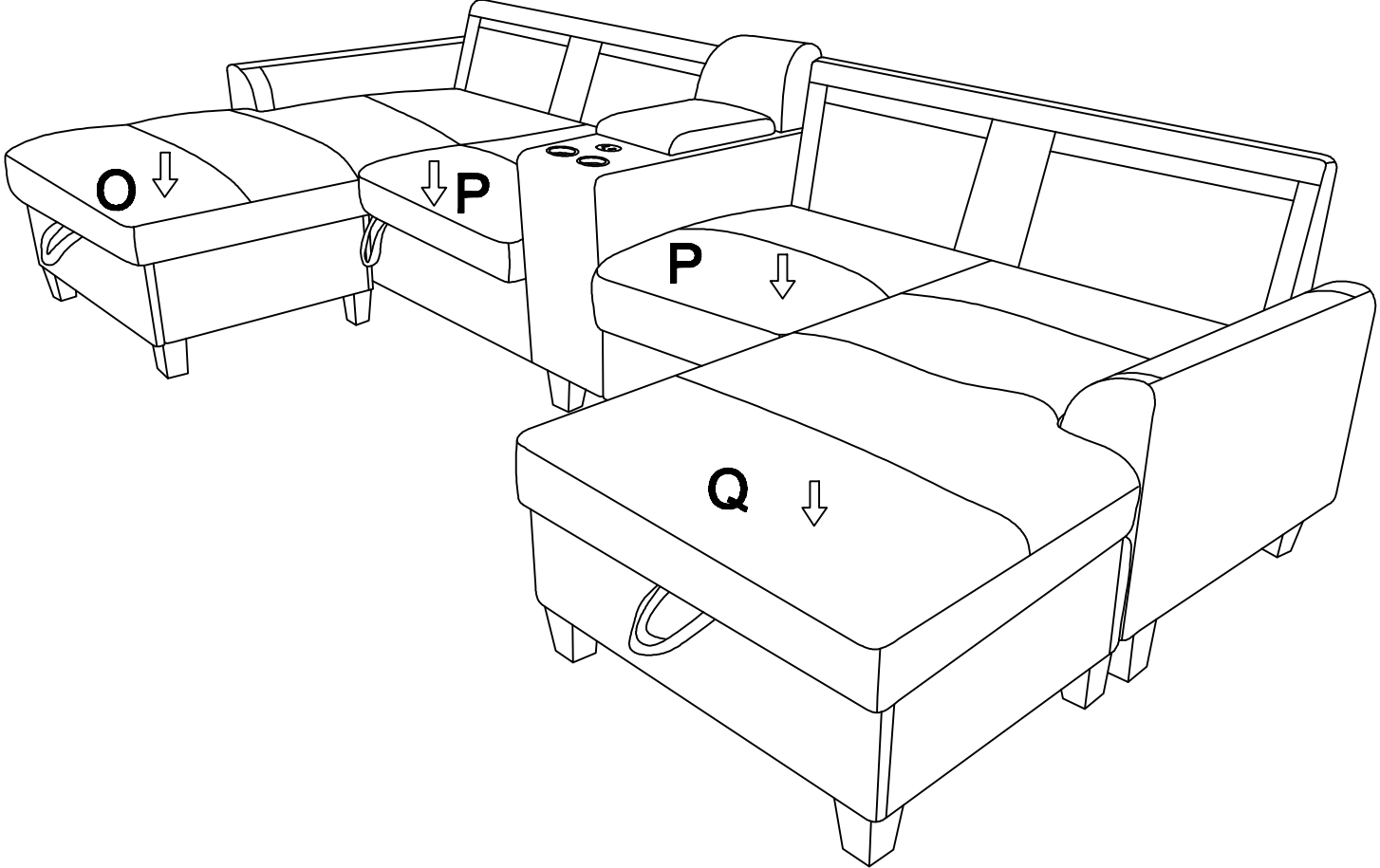

STEP 25

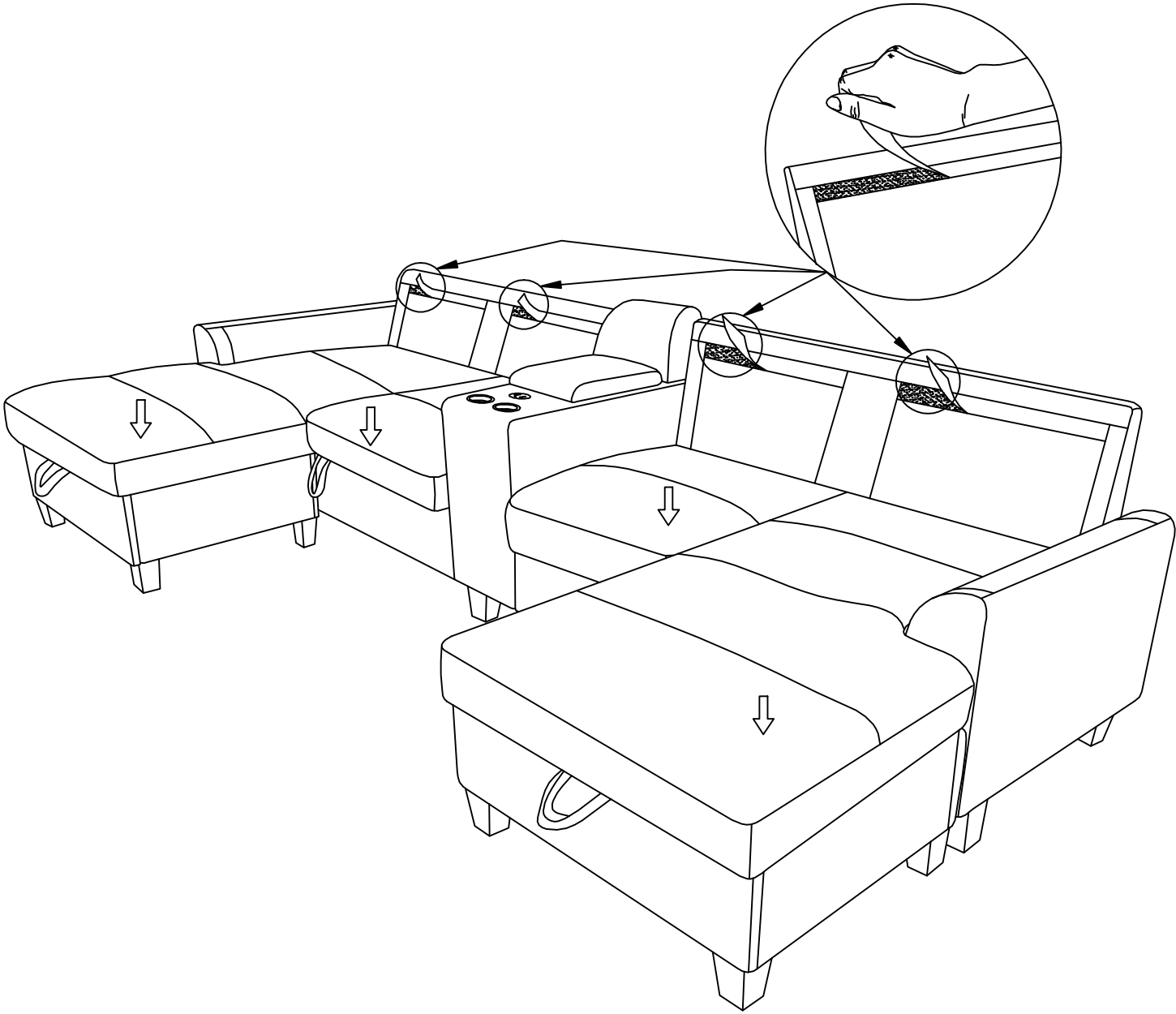

STEP 26

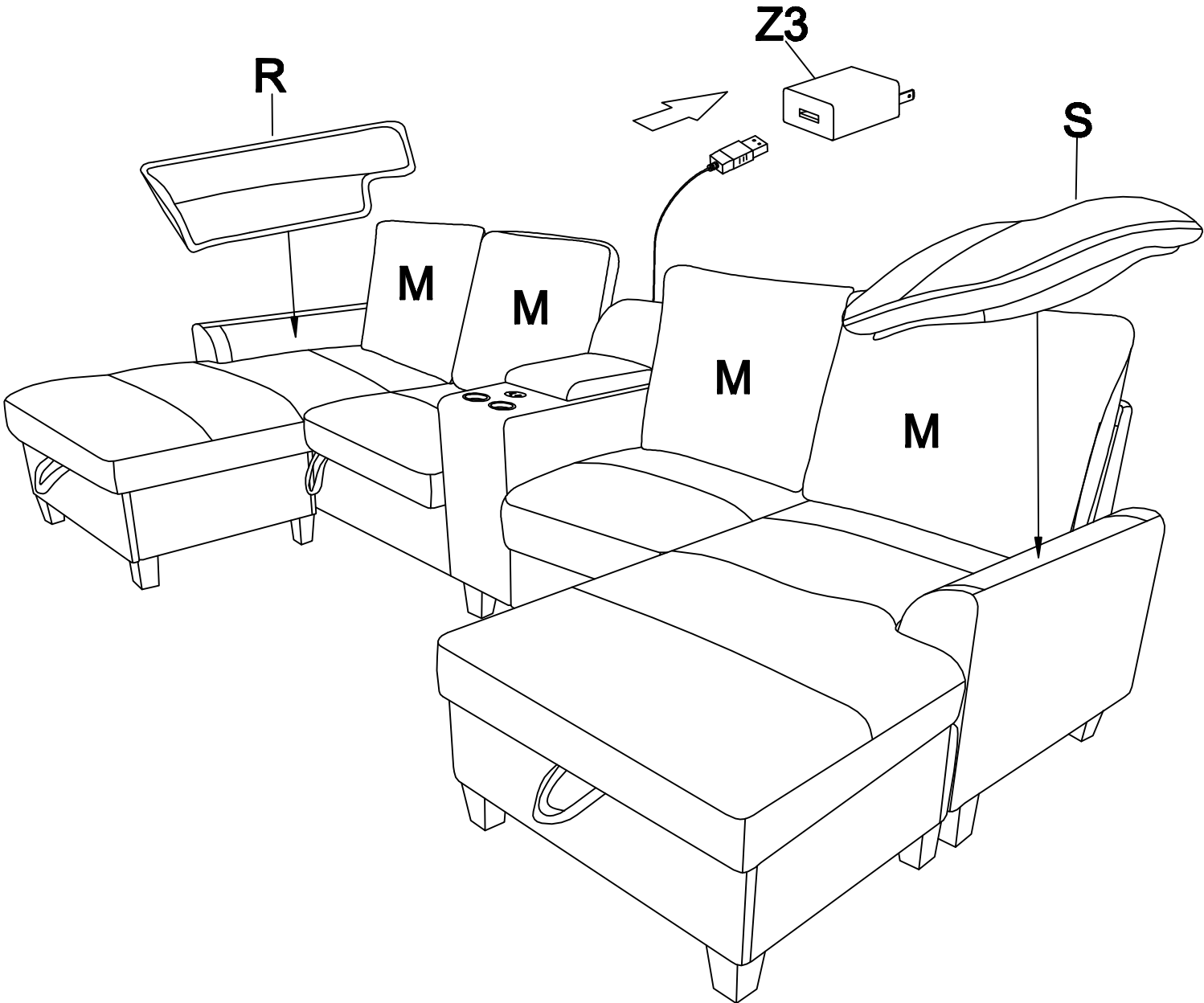

STEP 27

