

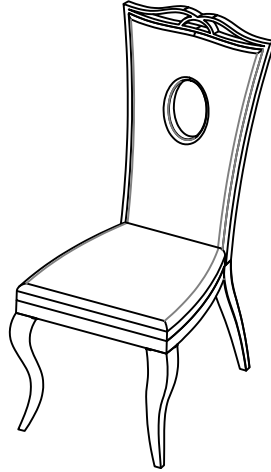



Item NO:DCK98 Dining chair

Assembly Instruction







ASSEMBLY TIME PER UNIT:	20MINUTES
-------------------------	-----------

PARTS IDENTIFICATION

A	BACK		1PC	B	SEATER		1PC
C	LEGS		2PCS				

HARDWARE LIST

NO.	SIZE	DIAGRAM	QTY	NO.	SIZE	DIAGRAM	QTY
1	Allen wrench		1	3	Flat washer		12
2	Bolts M8x25		12	4	Spring Shim		12

Item NO:DCK98 Dining chair

STEP1

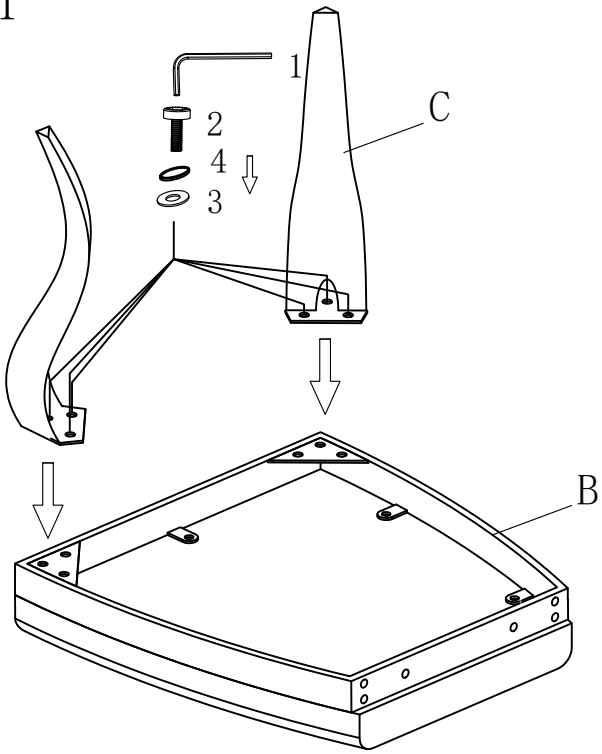

STEP2

