

# Assembly Instructions

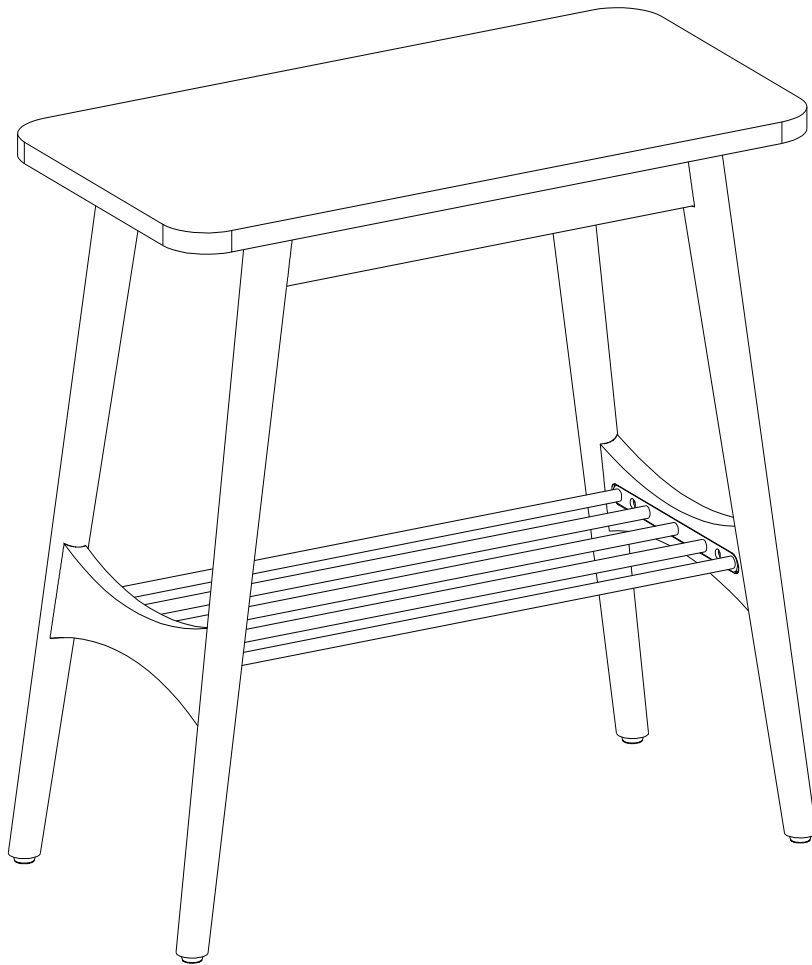

# General Assembly Guidelines

- I. Ensure that all parts and hardware are available before beginning assembly.
- II. Follow each step carefully to ensure the proper assembly of this product.
- III. Two people are recommended for ease in the assembly of this product.
- IV. The three main types of hardware used to assemble this product are : wood dowels , screws and bolts.
- V. The provided glue is to secure wood dowels in place . When first inserting dowels , locate the appropriate hole for the dowel , place a small amount of glue in the hole and insert the dowel . Wipe away excess glue immediatly.

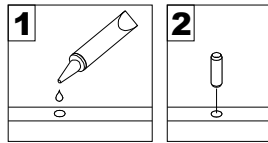

In future assembly steps when dowels are necessary to attach assembly parts together , place a small amount of glue on the end of the dowel before attaching parts together . Wipe away excess glue immediatly.

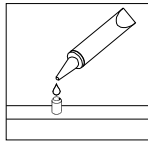

- VI. A Phillips head screwdriver is required for the assembly of this product .

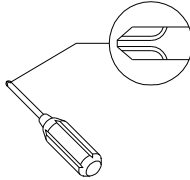



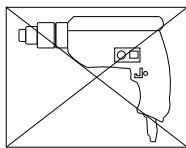



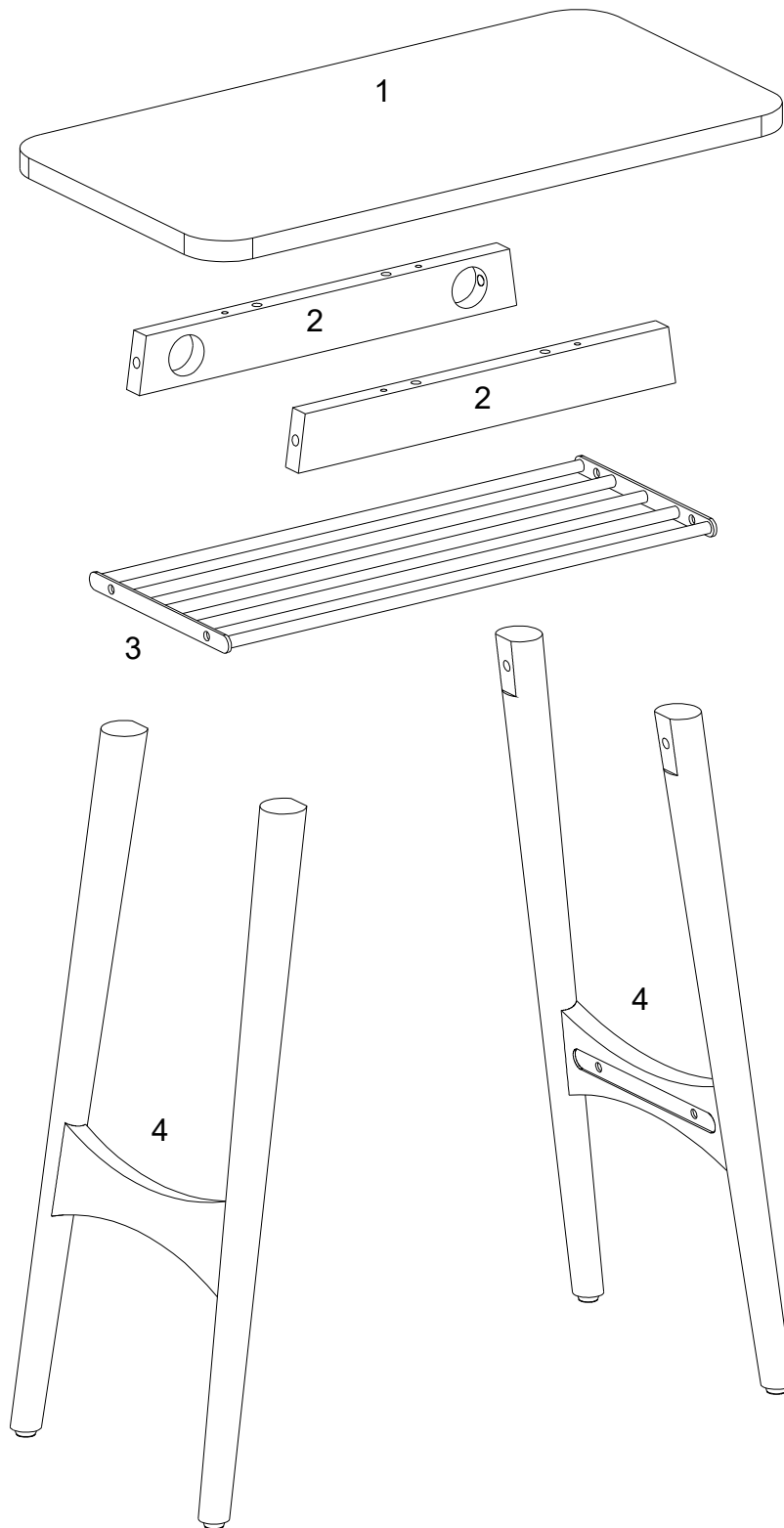

- VII. Power tools should not be used to assemble this product .



# Parts List

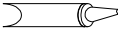

# Hardware List

A		Ø8x30mm	Wooden dowel	4	pcs
B		Ø4x38mm	Flat head	4	pcs
C		Ø6x15mm	Bolt	4	pcs
D		M 4	Hex key	1	pc
E			Glue tube	1	pc
F		Ø8x60mm	Bolt	4	pcs
G		Ø5/16	Washer	4	pcs
H		Ø5/16	Nut	4	pcs
J		Ø5/16	Wrench	1	pc

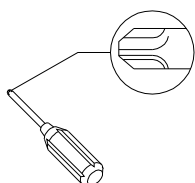

Philips head screwdriver required for assembly  
(not included)

*The hardware quantities listed above are required for proper assembly.  
Some extra hardware may also have been included.*

# Step 1

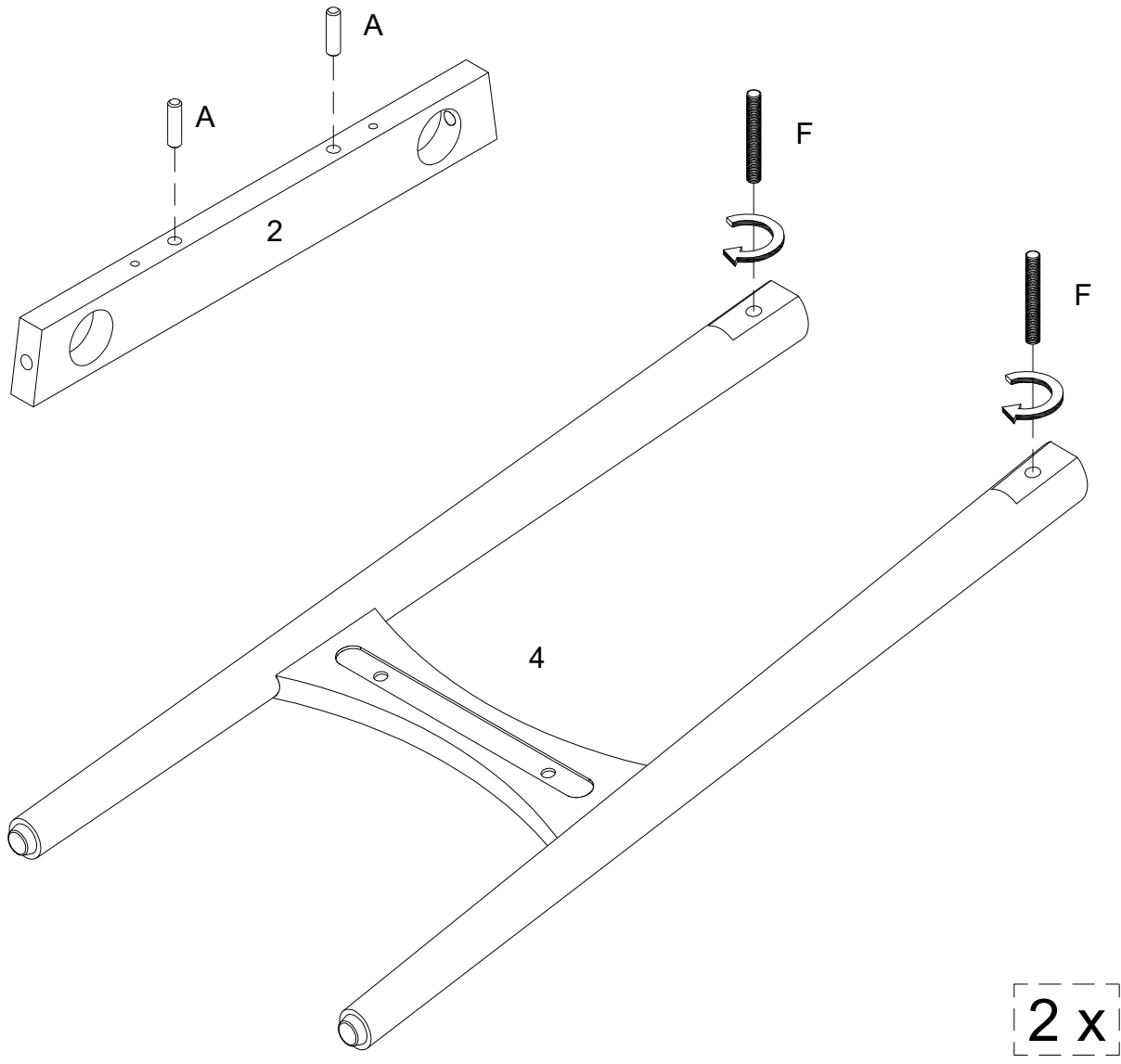

Insert wooden dowel (A) into part (2) and secure bolt (F) into part (4) as per diagram.

# Step 2

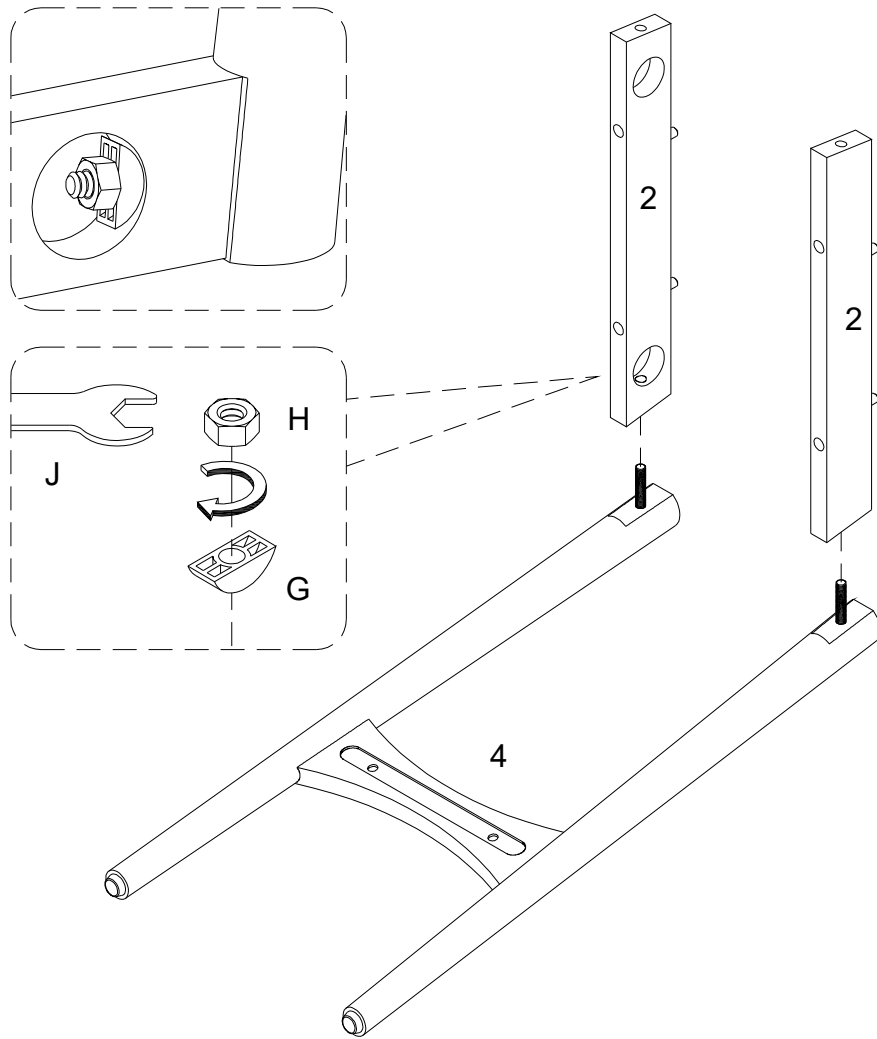

Using washer (G) and Nut (H) secure part (2) into part (4) with Wrench (J) as per diagram.

# Step 3

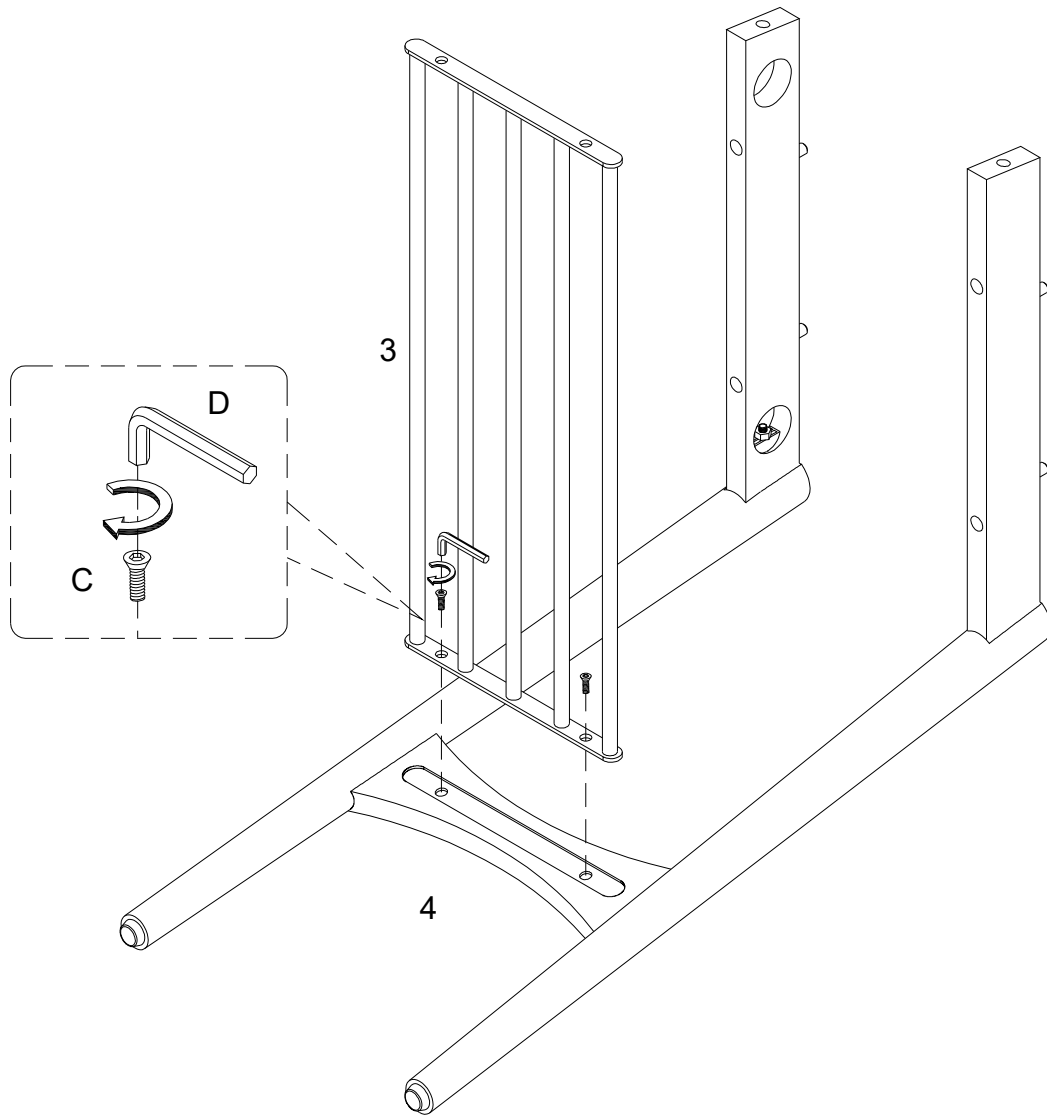

Using bolt (C) attach part (3) to part (4) with Hex key (D) as per diagram.  
Note: Do not fully tighten all bolts.

# Step 4

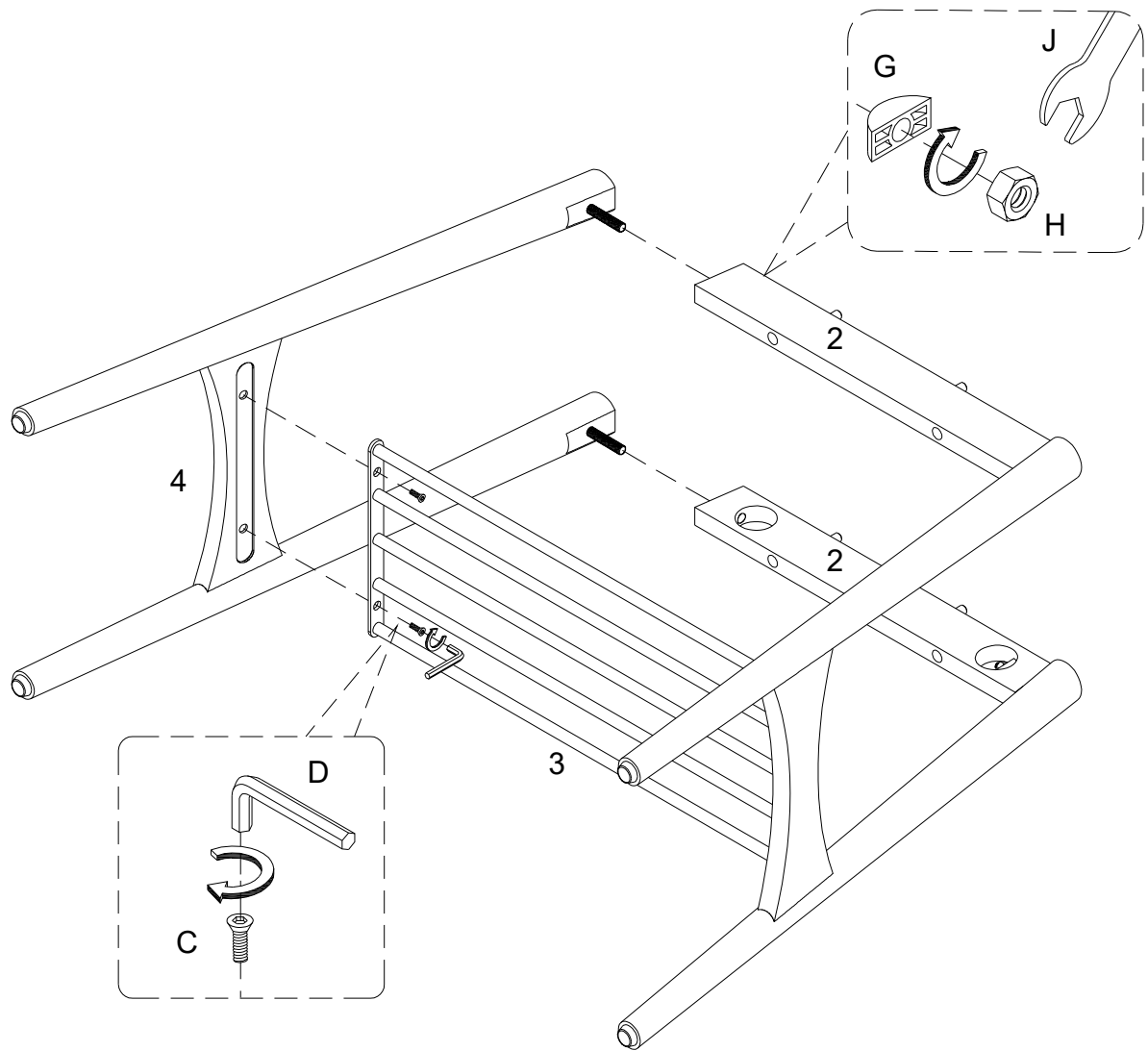

Using washer (G) and Nut (H) secure part (2) into part (4) with Wrench (J) ,then using bolt (C) attach part (3) to part (4) with Hex key (D) as per diagram.

# Step 5

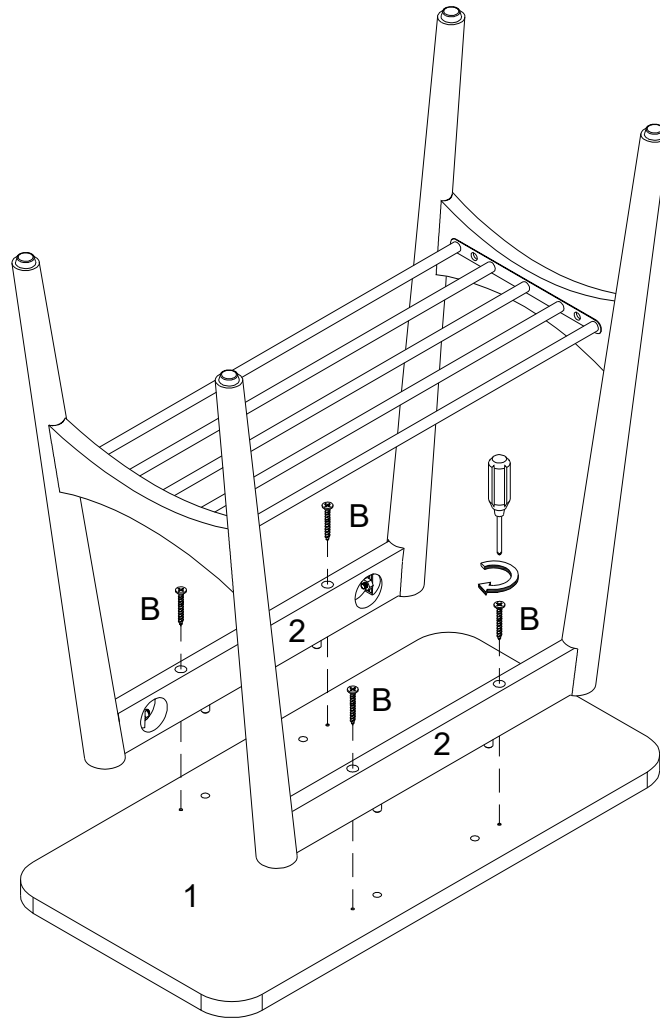

Using Flat head screw(B) secure part (2) to part (1) with Philips head screwdriver as per diagram.  
Note: Fully tighten all bolts.

# Step 6

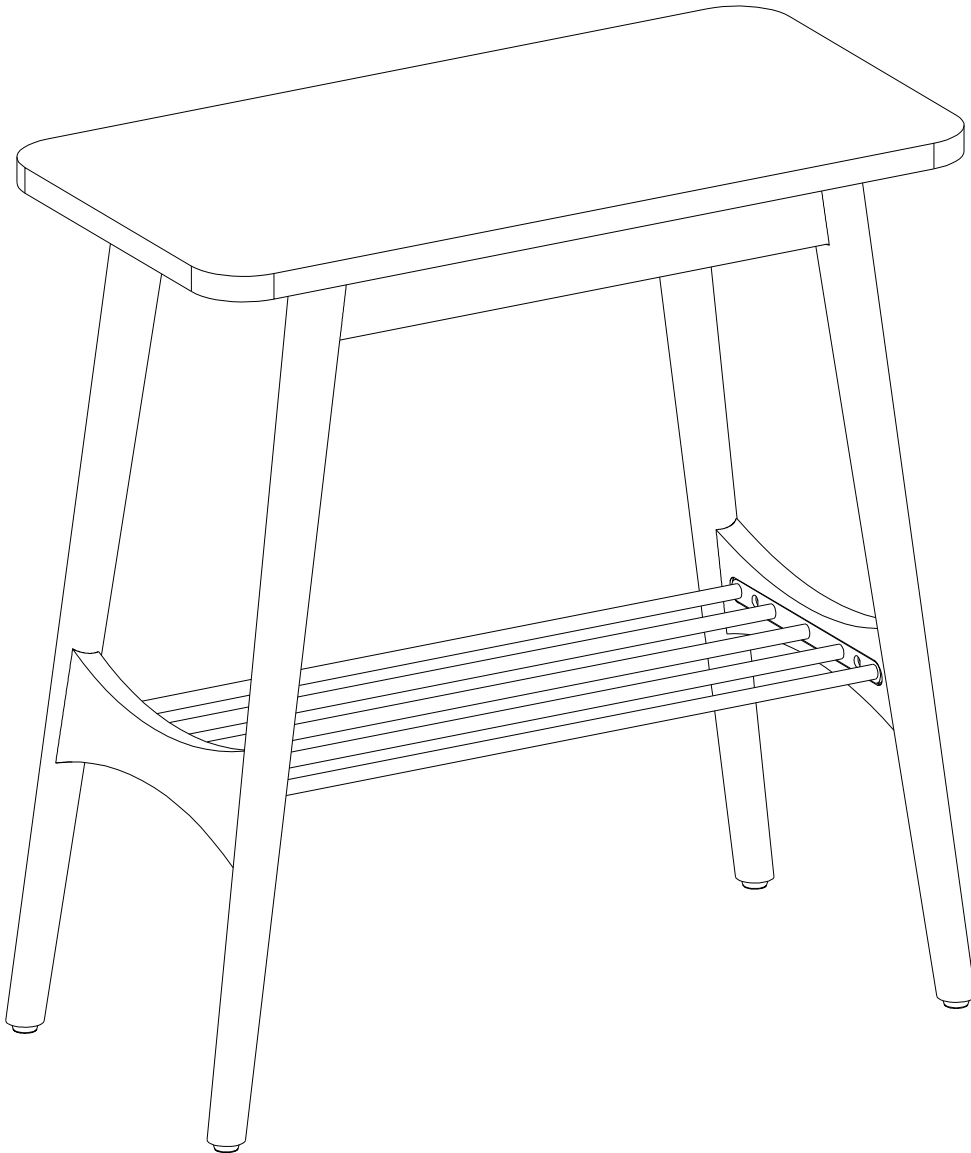

**Final Assembly**