

ASSEMBLY INSTRUCTIONS

DINING TABLE

IMPORTANT NOTE :





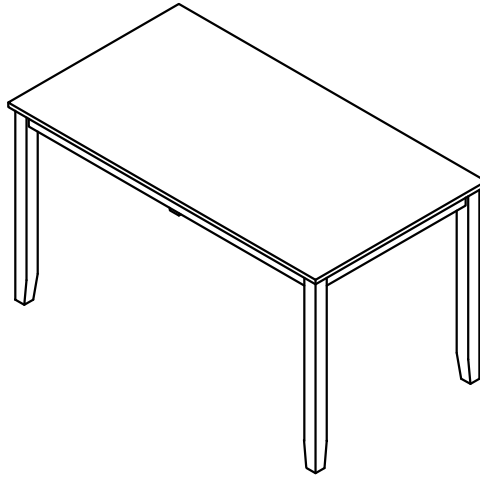

** PLACE ALL PARTS ON A CLEAN AND SMOOTH SURFACE SUCH AS A RUG OR CARPET TO AVOID THE PARTS FROM BEING SCRATCHED.

** BEFORE YOU BEGIN, KINDLY FOLLOW THE ASSEMBLY INSTRUCTIONS STEP BY STEP.

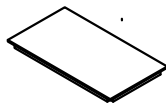
**DO NOT TIGHTEN ALL SCREWS AND BOLTS UNTIL THE TABLE IS FULLY SET-UP.

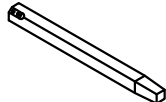

CARTONS ONLY ONE/ CARTONS SEULEMENT UN

| PART LISTS | | | | HARDWARE LISTS | | | |
|------------|-------------|---|-------|----------------|---------------------------------|---|-------|
| NO. | DESCRIPTION | SKETCH | Q'TY | NO. | DESCRIPTION | SKETCH | Q'TY |
| 1 | TABLE TOP |  | 1 PC | A | BOLT Ø5/16" x 60mmL |  | 8 PCS |
| 2 | LEGS |  | 4 PCS | B | SPRING WASHER Ø5/16" x 13mmL |  | 8 PCS |
| | | | | C | FLAT WASHER Ø5/16" x 19mmL |  | 8 PCS |
| | | | | D | ALLEN KEY |  | 1 PC |

ASSEMBLY INSTRUCTIONS

STEP 1:

Remove the corner protectors before assembly leg

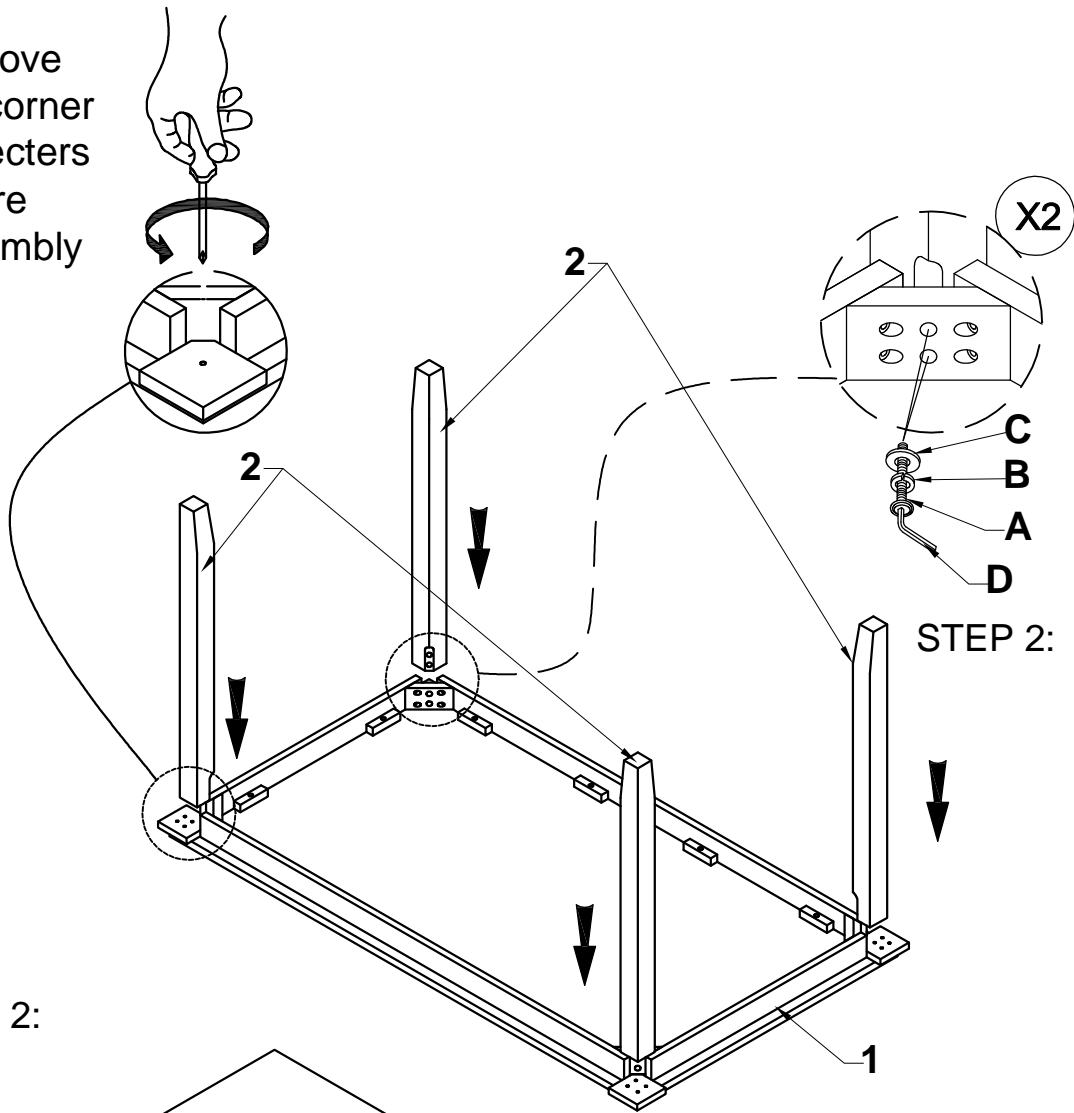

STEP 2:

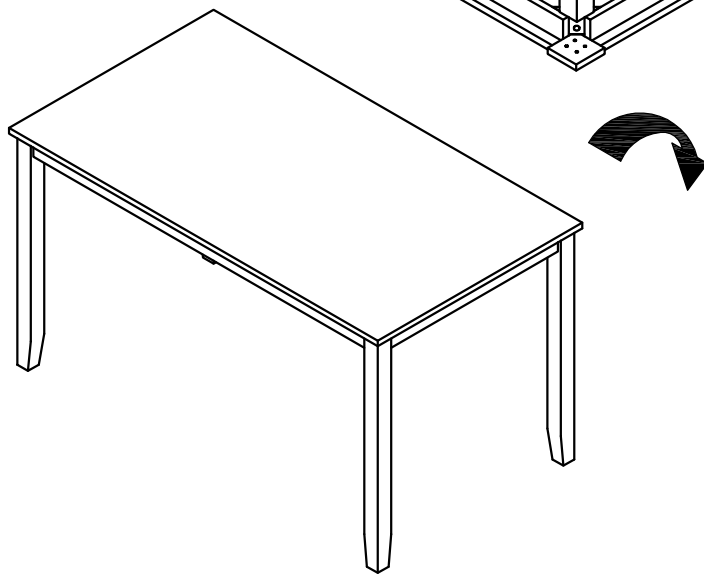

ASSEMBLY INSTRUCTIONS

DINING CHAIR

IMPORTANT NOTE :







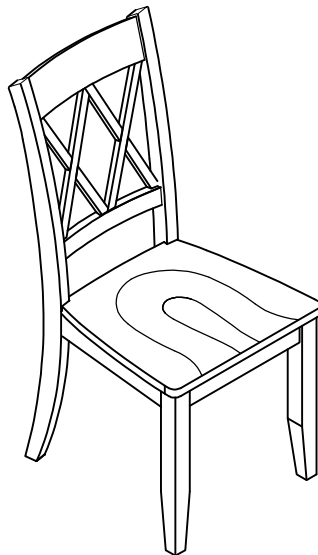

** PLACE ALL PARTS ON A CLEAN AND SMOOTH SURFACE SUCH AS A RUG OR CARPET TO AVOID THE PARTS FROM BEING SCRATCHED.

** BEFORE YOU BEGIN, KINDLY FOLLOW THE ASSEMBLY INSTRUCTIONS STEP BY STEP.

**DO NOT TIGHTEN ALL SCREWS AND BOLTS UNTIL THE CHAIR IS FULLY SET-UP.



CARTONS ONLY ONE/ CARTONS SEULEMENT UN

| PART LISTS | | | | HARDWARE LISTS | | | |
|------------|-------------|---|-------|----------------|--------------------------------|---|-------|
| NO. | DESCRIPTION | SKETCH | Q'TY | NO. | DESCRIPTION | SKETCH | Q'TY |
| 1 | CHAIR BACK |  | 1 PC | A | BOLT Ø1/4" x 75mmL |  | 4PCS |
| 2 | SEAT |  | 1 PC | B | BOLT Ø1/4" x 60mmL |  | 4PCS |
| 3 | FRONT LEGS |  | 2 PCS | C | BOLT Ø1/4" x 38mmL |  | 2PCS |
| | | | | D | SPRING WASHER Ø1/4" x 13mmL |  | 10PCS |
| | | | | E | FLAT WASHER Ø1/4" x 19mmL |  | 10PCS |
| | | | | F | ALLEN KEY |  | 1PC |

ASSEMBLY INSTRUCTIONS

STEP 1:

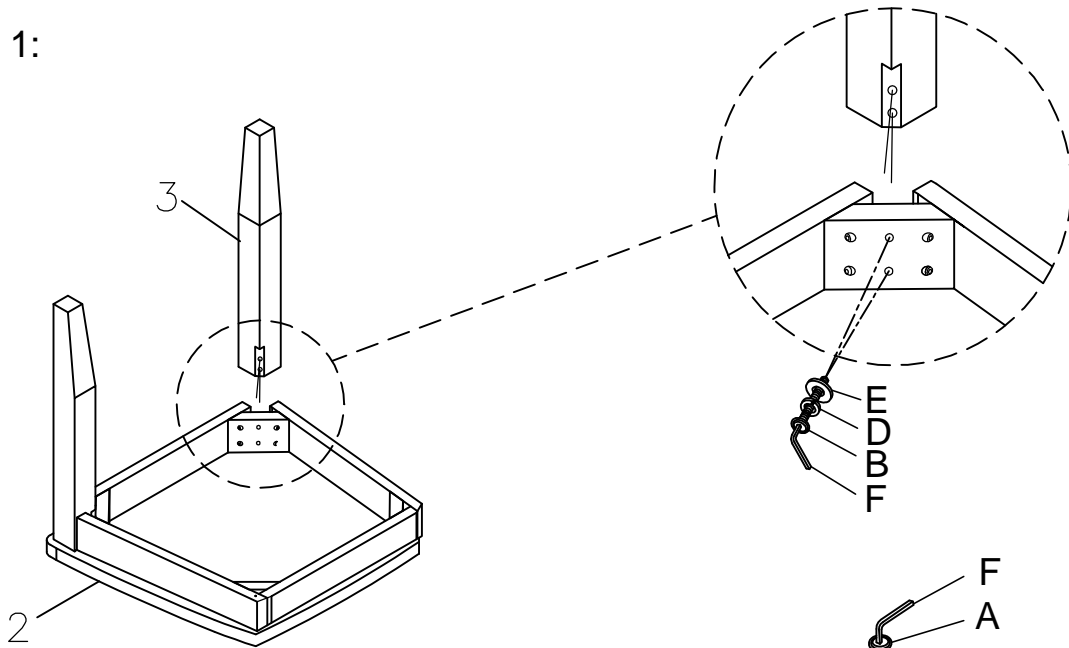

STEP 2:

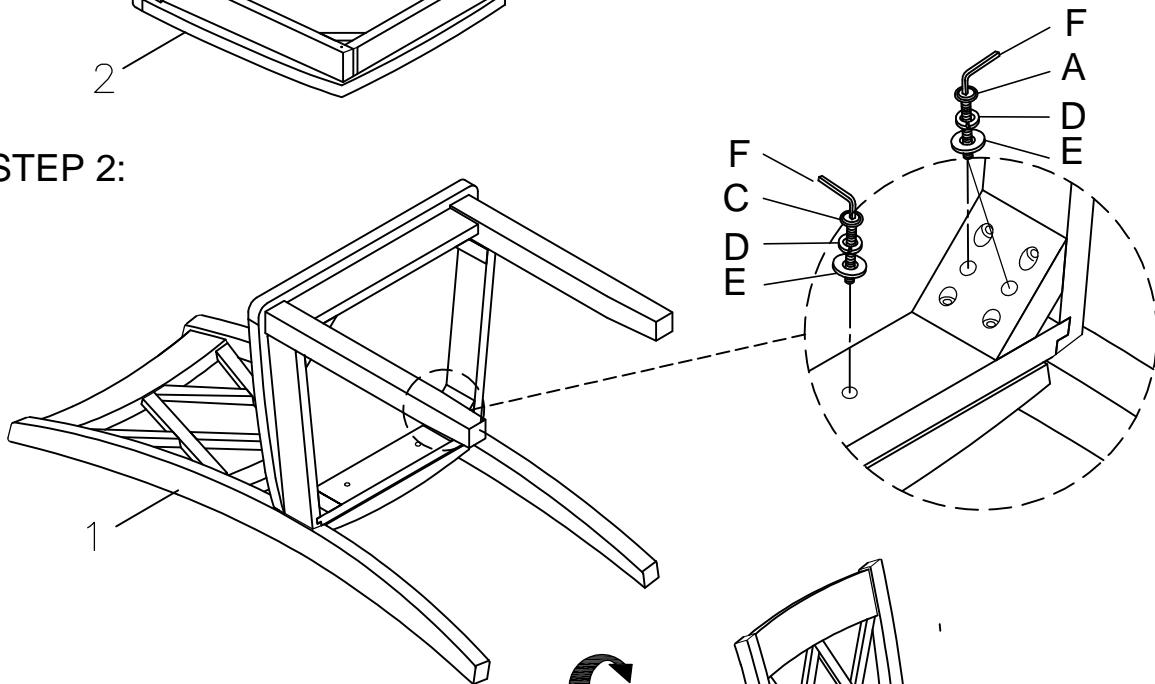

STEP 3:

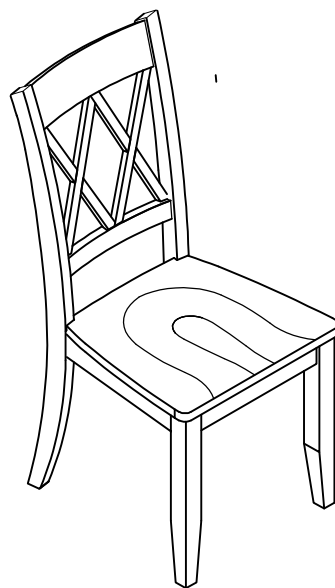

ASSEMBLY INSTRUCTIONS

DINING BENCH

IMPORTANT NOTE :





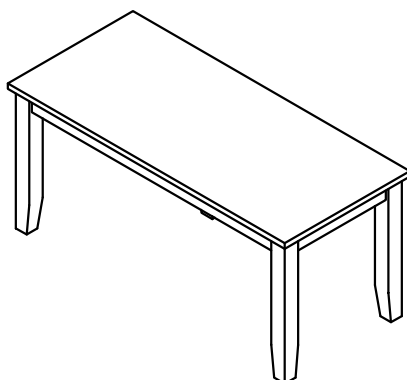

** PLACE ALL PARTS ON A CLEAN AND SMOOTH SURFACE SUCH AS A RUG OR CARPET TO AVOID THE PARTS FROM BEING SCRATCHED.

** BEFORE YOU BEGIN, KINDLY FOLLOW THE ASSEMBLY INSTRUCTIONS STEP BY STEP.

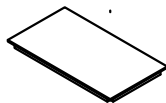
**DO NOT TIGHTEN ALL SCREWS AND BOLTS UNTIL THE TABLE IS FULLY SET-UP.

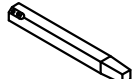

CARTONS ONLY ONE/ CARTONS SEULEMENT UN

| PART LISTS | | | | HARDWARE LISTS | | | |
|------------|-------------|---|-------|----------------|--------------------------------|---|-------|
| NO. | DESCRIPTION | SKETCH | Q'TY | NO. | DESCRIPTION | SKETCH | Q'TY |
| 1 | BENCH TOP |  | 1 PC | A | BOLT Ø1/4" x 60mmL |  | 8 PCS |
| 2 | LEGS |  | 4 PCS | B | SPRING WASHER Ø1/4" x 13mmL |  | 8 PCS |
| | | | | C | FLAT WASHER Ø1/4" x 19mmL |  | 8 PCS |
| | | | | D | ALLEN KEY |  | 1 PC |

ASSEMBLY INSTRUCTIONS

STEP 1:

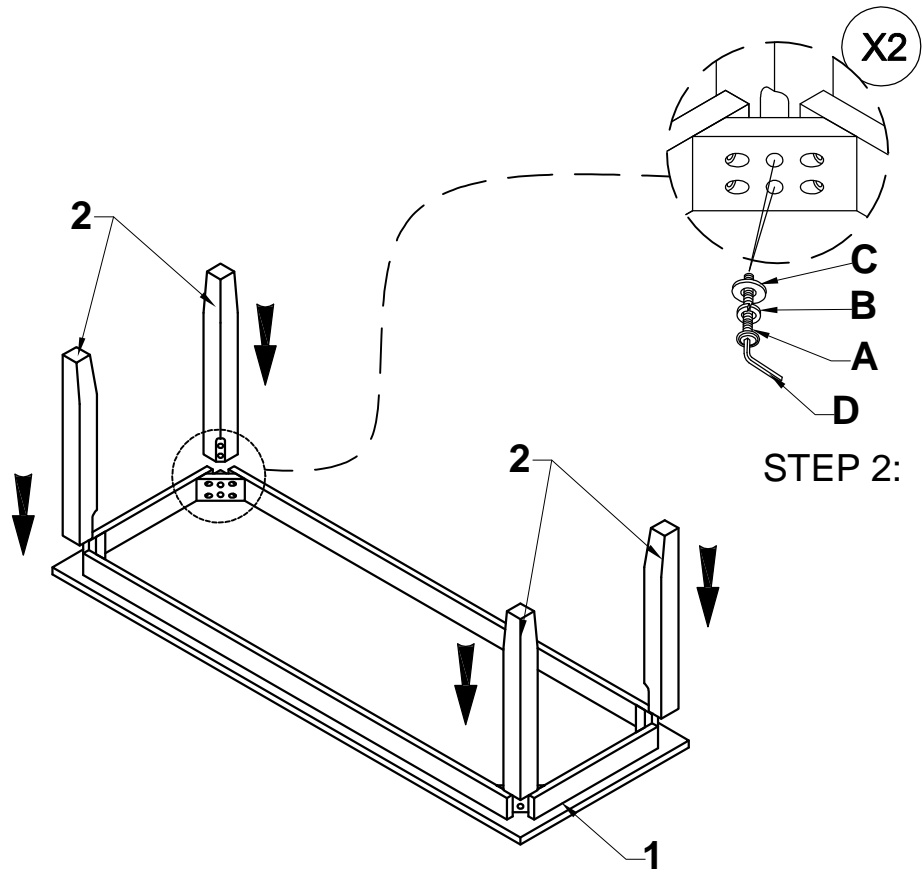

STEP 2:

STEP 2:

