

Swivel Chair

INSTRUCTION MANUAL

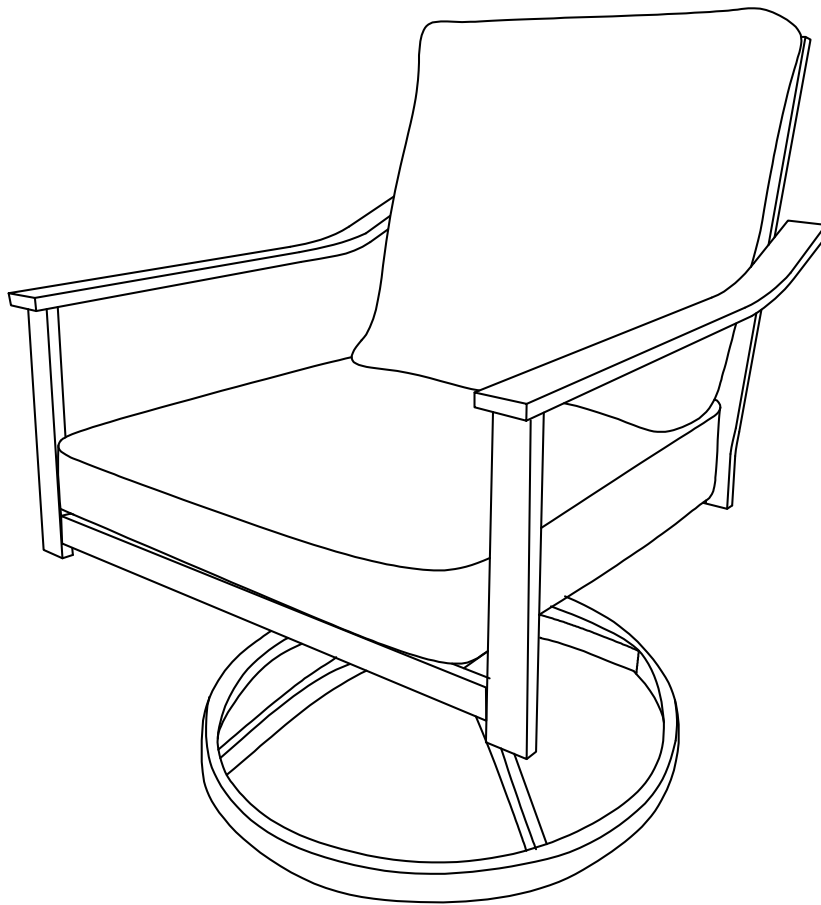

IMPORTANT: READ THIS INSTRUCTION CAREFULLY BEFORE PROCEEDING.

This manual will provide you with clear and detailed instructions on how to safely and correctly assemble and maintain your Swivel Chair, to ensure it brings you enjoyment.

FOLLOW US ON

 @abbapatio

 @abbapatio









 @Abba_Patio

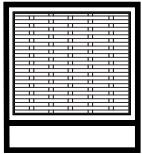
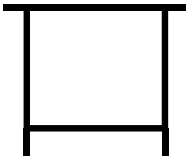

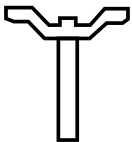
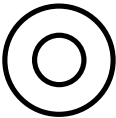



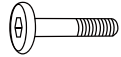
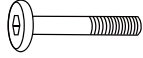
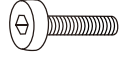

 @abbapatio_official

PARTS LIST

Make sure all parts listed below have been included in your package.

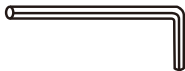

Tool required,
not included 

REF	PART NAME	QTY (PER UNIT)	QTY (PER BOX)
A 	Backrest	1	4
B 	Seat	1	4
C 	Left Armrest	1	4
D 	Right Armrest	1	4
E 	Seat Post	1	4
F 	Decorative Plastic Cover	1	4
G 	Base	1	4
H 	Back Cushion	1	4
I 	Seat Cushion	1	4
J 	Bolt M6x15mm	4	16+2
K 	Bolt M6x20mm	2	8+2

	REF	PART NAME	QTY (PER UNIT)	QTY (PER BOX)
L		Bolt M6x40mm	1	4+1
M		Bolt M6x55mm	2	8+2
N		Bolt M8x30mm	4	16+2
O		Washer d8.5*D17	4	16+2
P		Washer d6.5*D13	8	32+4
Q		Washer d8.5*D12	4	16+2
R		Washer d6.5*D30	1	4+1
S		Jam Nut M8*1.25mm	4	16+2
T		Gasket	2	8
U		Hex Key 4mm	1	1
V		Hex Key 6mm	1	1
W		Hex Wrench 10mm & 13mm	1	1



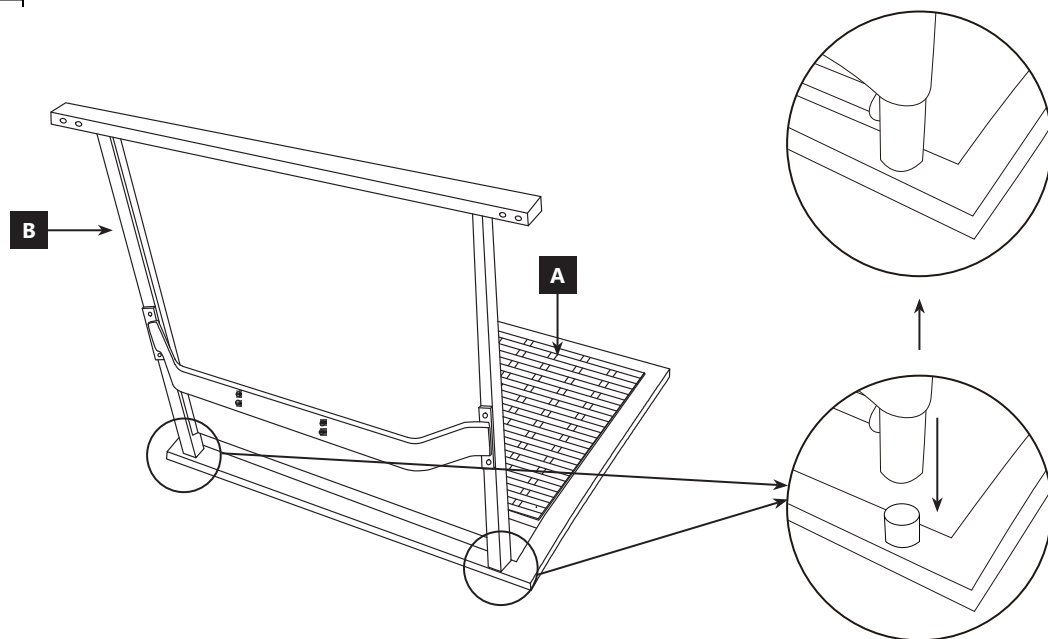

ASSEMBLY

1. Back & seat assembly

- A** x1 
- B** x1 







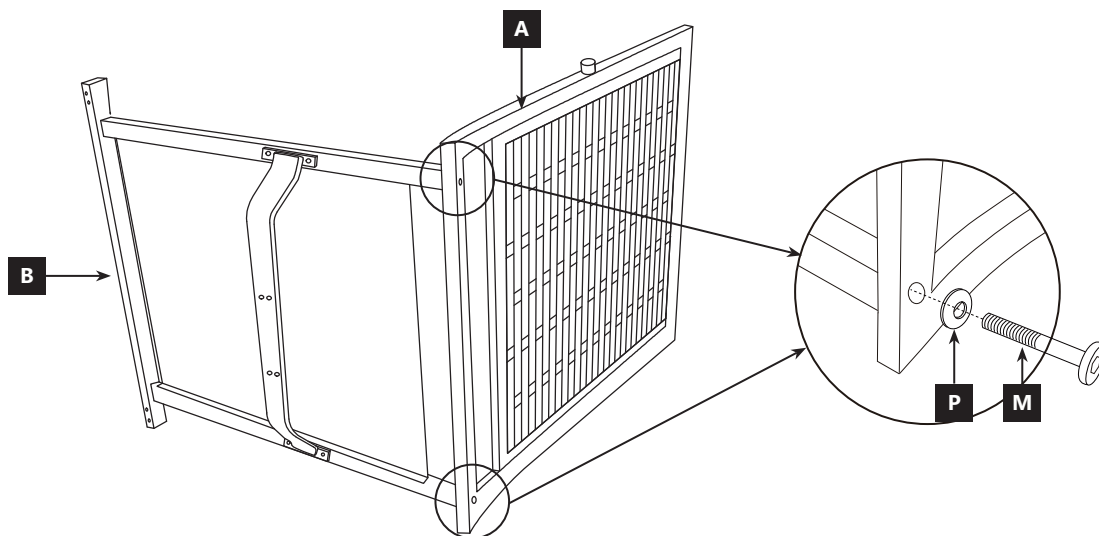

1A) Insert the seat **B** to the backrest **A**.

- U** x1  or 
- M** x2 
- P** x2 



1B) Secure the backrest **A** and the seat **B** with screw **M** and washer **P**.

2. Armrest assembly



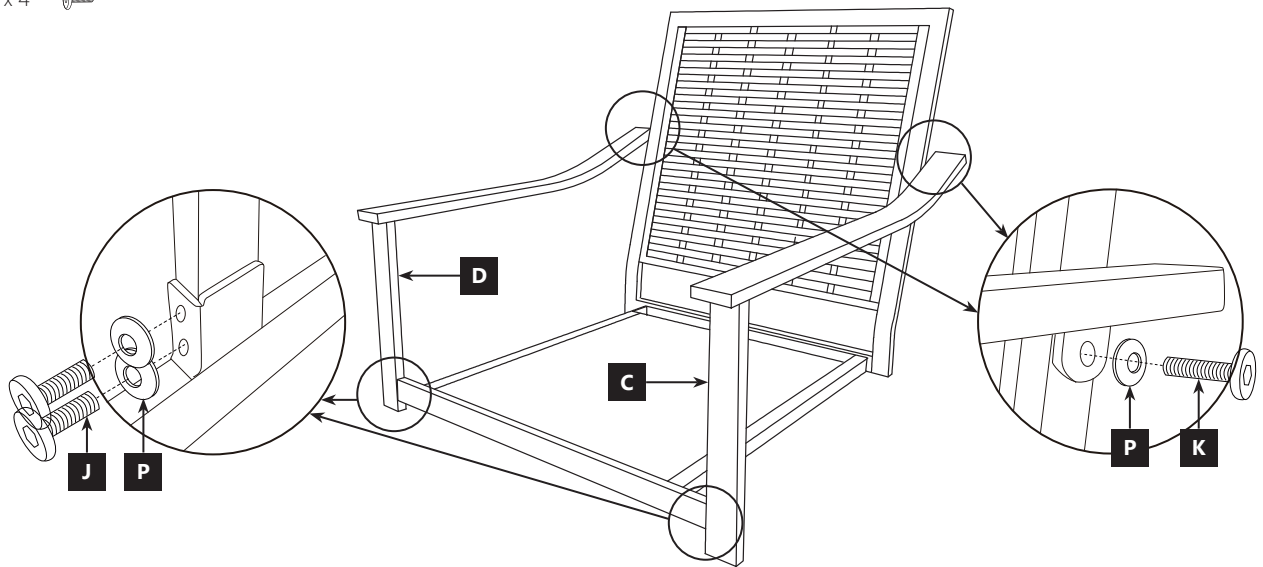





- U** x1  or 
- C** x1  **K** x2 
- D** x1  **P** x6 
- J** x4 



2A) Secure the left armrest **C** and right armrest **D** to the seat **B** with the screw **J** and washer **P**.

2B) Secure the left armrest **C** and right armrest **D** to the backrest **A** with the screw **K** and washer **P**.

3. Seat post assembly

- V** x1  **W** x1  or 
- E** x1  **Q** x4 
- N** x4  **S** x4 
- O** x4  **T** x2 

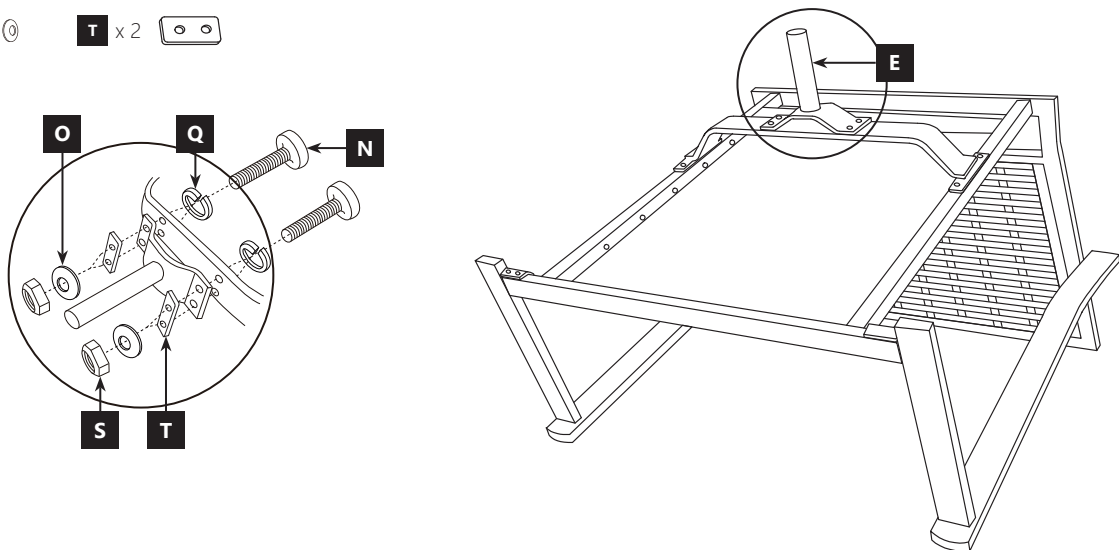



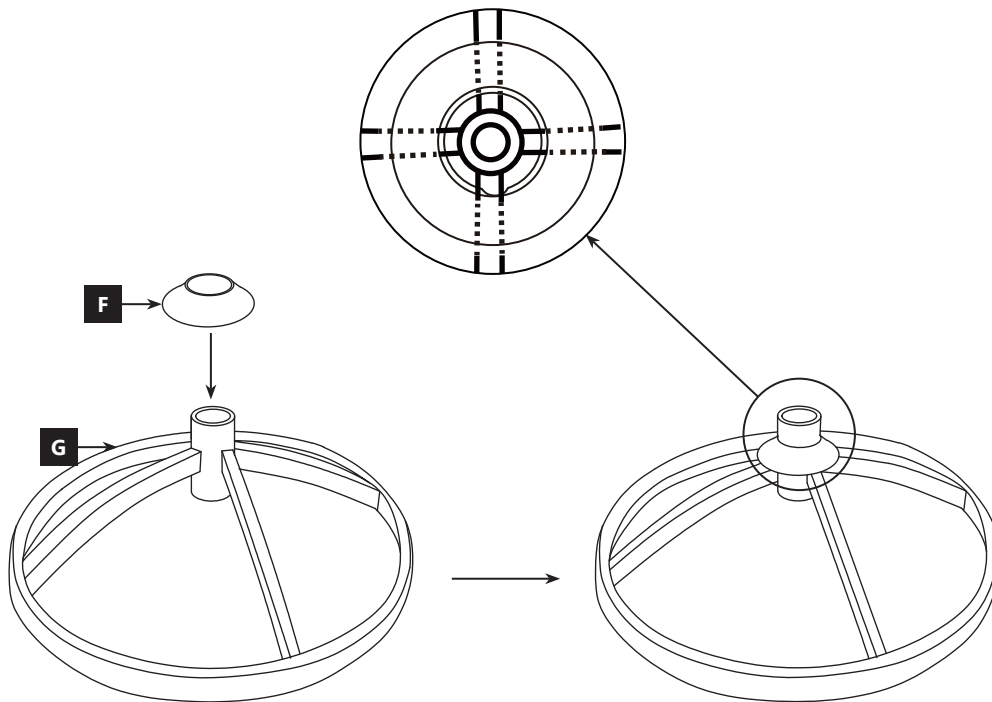

2A) Secure the seat post **E** with screw **N**, washer **O** and **Q**, jam nut **S** and gasket **T**.

4. Base assembly

- F** x1 
- G** x1 



4A) Thread the decorative plastic cover **F** onto shaft of the base **G**.

- U** x1  or 
- L** x1 
- R** x1 

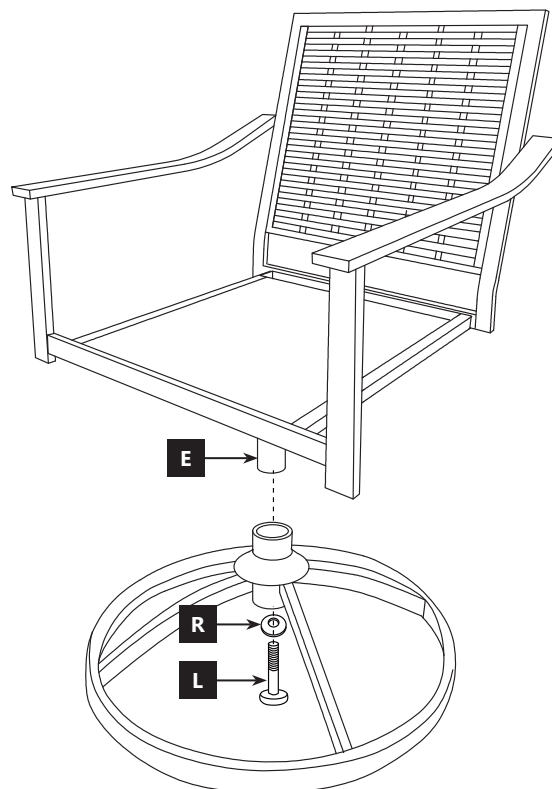

4B) Insert the seat post **E** into the base assembly. Secure them with screw **L** and washer **R**.

6. Put cushion

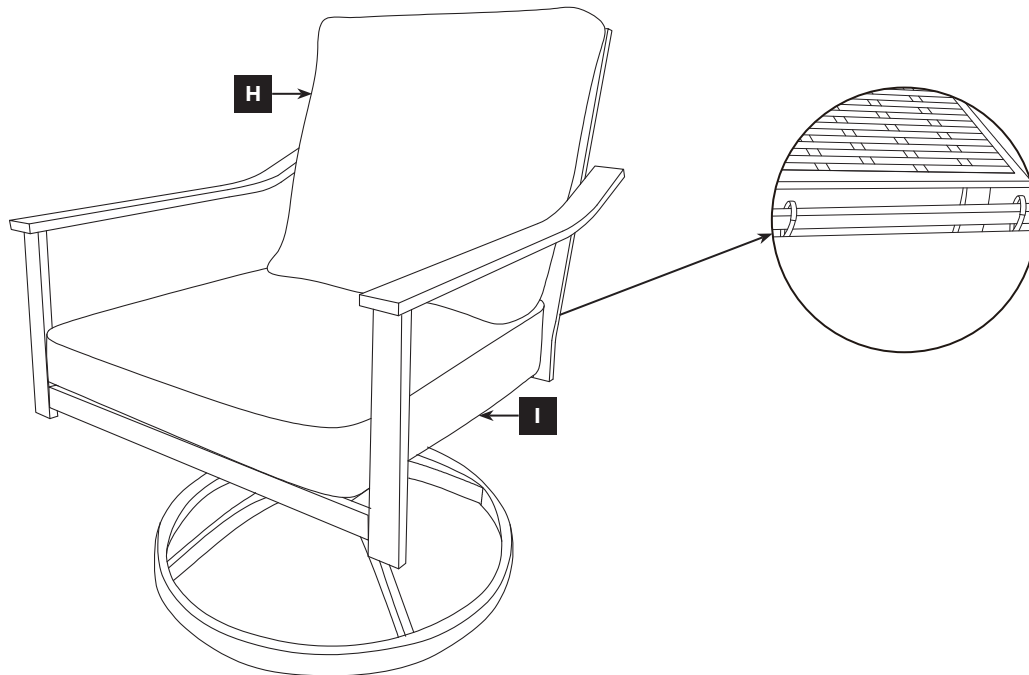
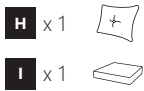

4A) Put the back cushion **H** and the seat cushion **I** on the chair. Secure the seat cushion **I** with touch fastener.

IMPORTANT INFORMATION

IMPORTANT! Read this information before proceeding.

WARNING:

When using the swivel chair products outdoors, basic safety precautions should be followed to reduce unnecessary hazards, including the following:

- Adult assembly required.
- Choking hazard to children under the age of 3 years-contains small parts prior to assembly.
- Do be careful that some parts are heavy and sharp.
- Do not place the swivel chair in environments with flammable or caustic chemicals.
- Keep assembly areas clear of obstacles such as facades, garages, houses, overhanging tree branches, laundry lines, or electrical wires.
- Do not stand on the chair, nor adopt unsafe sitting positions on it.
- When the product is evenly loaded, the swivel chair holds up to 496 lbs (225 kg).
- Do not place items beyond the edge of the product, and prevent items from falling.
- Do not allow children to climb on or play on the product to avoid serious bodily injury caused by the falling.
- Assemble the item on a soft, non-abrasive surface, such as carpet or cardboard to avoid damaging the item.
- Do not attempt to assemble the swivel chair in windy or wet conditions.
- Keep children and pets away from the assembly area until the work is completed.
- Before each use, inspect the swivel chair for any signs of damage. Do not use if any parts are damaged, and replace worn or broken parts immediately.
- Never continue to use a product that is structurally unsound.
- Do not touch moving parts during operation.
- Keep clothing and body parts away from the swivel chair to prevent them from getting caught in the moving parts
- Outdoor furniture is not made to bear low temperature conditions, which are likely to alter its correct operating and its surface condition.
- Please recycle packaging where possible.

CARE & MAINTENANCE

- The swivel chair is guaranteed to be free from any manufacturing defects for a period of 1 year from the date of purchase under normal use and in compliance with the open rating instructions.
- The warranty is valid only in the original country of purchase. Abba Patio® reserves the right to exchange an item for a replacement part. Some parts may be replaced with newer purchase model parts as the product is improved over time.

FRAME:

- Dust and dirt will collect on the swivel chair and will require periodic cleaning.
- Be sure to drain any water accumulated inside the frames. Air dry or wipe with a soft clean cloth.
- Clean surfaces with a dry or damp soft cloth. Do not use abrasive cleaners.
- Protect furniture with anti-rust spray and use regularly.
- When not in use, please store the furniture in a dry place and avoid direct sunlight to prevent material aging and deformation.
- If rust appears, it can be removed with a common product such as white vinegar or citric acid, or a cloth soaked in car polish can also help you remove rust.
- Only Abba Patio® replacement parts should be used. It may be unsafe to use parts supplied by another manufacturer.

FABRIC:

1. Brush off loose dirt with a soft bristle brush.
2. Hose down.
3. Prepare a cleaning solution of water and mild.
4. Use a soft bristle brush to clean.
5. Allow cleaning solution to soak into the fabric.
6. A thorough rinse until all soap residue is removed.
7. Air dry.

CLEANING METHODS FOR DIFFERENT STAINS:

Oil-based spills.

1. Apply an absorbent such as corn starch, then remove with a straight edge.
2. Spray on mild cleaning solution of soap and water.
3. Rinse the fabric thoroughly to remove all soap residue.
4. Air dry.

Mildew.

1. Prepare a solution of 1 cup and 1/4 cup mild soap per gallon of water.
2. Spray on entire area and allow to soak into the fabric for 15 minutes.
3. Clean entire surface area with a sponge, clean towel or very soft bristle brush.
4. Rinse thoroughly to remove all soap residue.
5. Air dry.

CONTACT US FOR HELP

Customer Service: customer@abbapatio.com

Need Assistance? Call +1 (888) 899-5617

Hours of Operation:

Phone Support: Monday - Friday: 6:30 am - 4:30 pm, Saturday – Sunday: 8:30 am – 4:30 pm, PST.

Email Support: We are available 24 hours a day. Please allow up to 24 hours for a response.

Note: Our team is available to assist you during these hours. If you have any inquiries or require support outside of these hours, please leave a voicemail, send an email. We will get back to you promptly during the next available support hours. We thank you for your purchase!