

ASSEMBLY INSTRUCTIONS



Fine Furniture for every stage of life

Dining Table

ASSEMBLY INSTRUCTIONS

ASSEMBLY TIPS:

1. Remove hardware from box and sort by size.
2. Please check to see that all hardware and parts are present prior to start of assembly.
3. Please follow attached instructions in the same sequence as numbered to assure fast & easy assembly.



WARNING!

1. Don't attempt to repair or modify parts that are broken or defective. Please contact the store immediately.
2. This product is for home use only and not intended for commercial establishments.



ASSEMBLY TIME

15 MINUTES

PARTS IDENTIFICATION

AN TOP

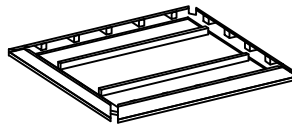

1PC

BN LEG



4PCS

HARDWARE IDENTIFICATION

1 ALLEN WRENCH
(M4 x 59mm - BLK)

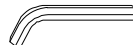

1PC

2 BOLT
(5/16" x 90mm - BLK)

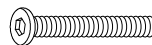

8PCS

3 FLAT WASHER
(5/16" - BLK)



8PCS

4 LOCK WASHER
(5/16" - BLK)



8PCS

ASSEMBLY INSTRUCTIONS

STEP 1

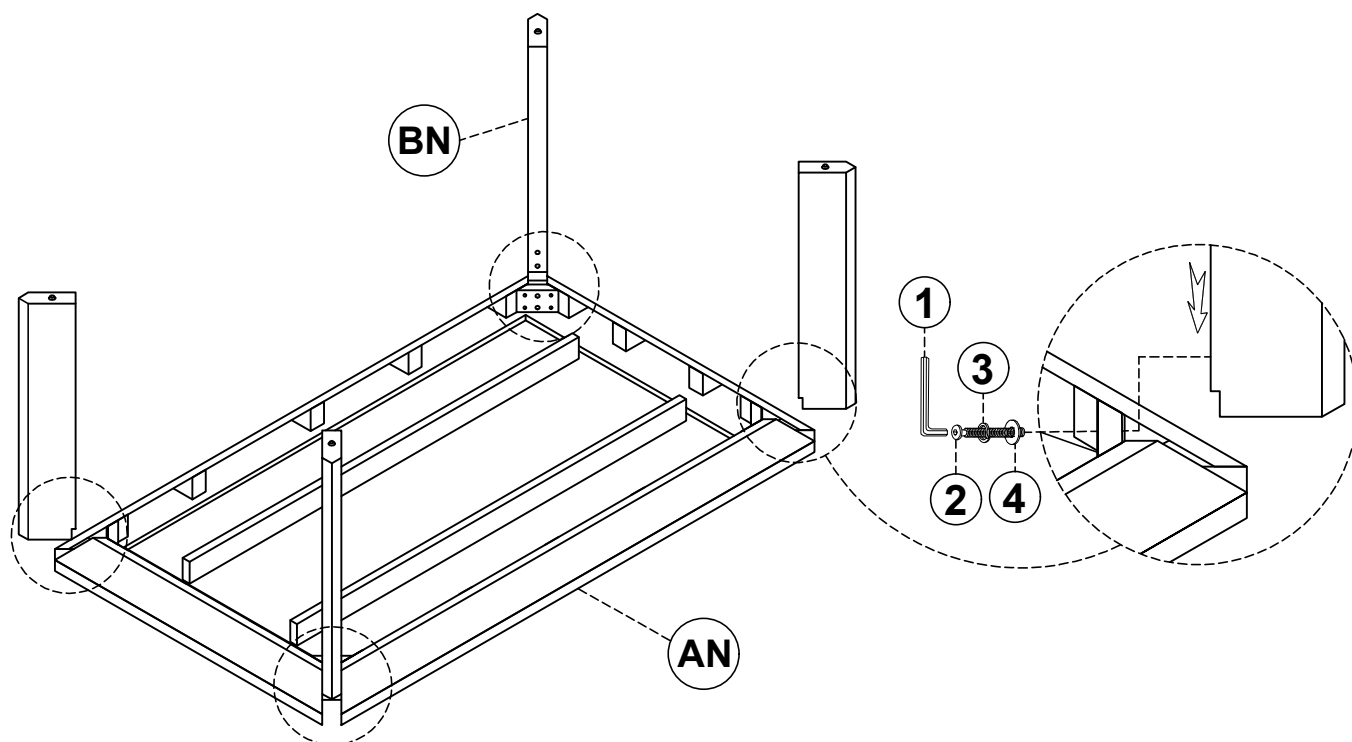

STEP 2 COMPLETE

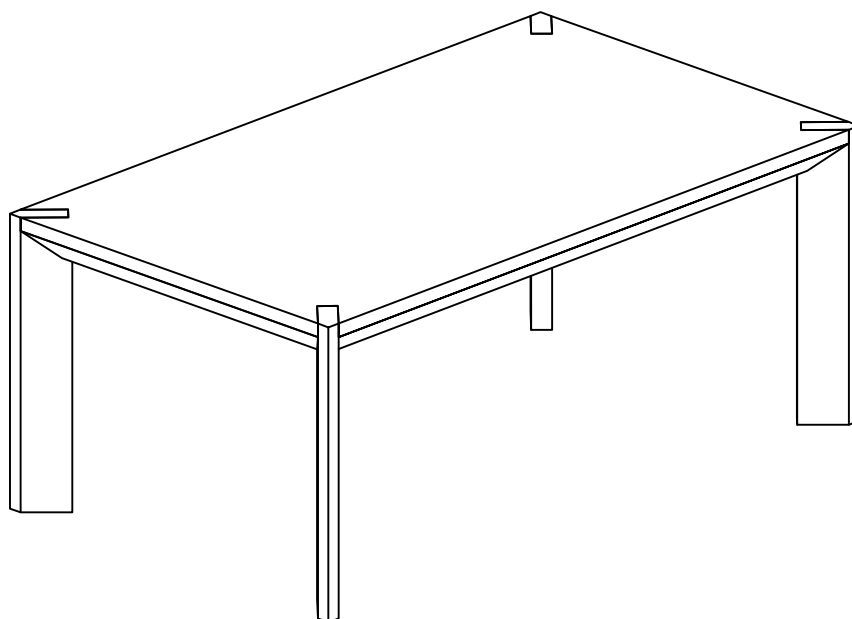

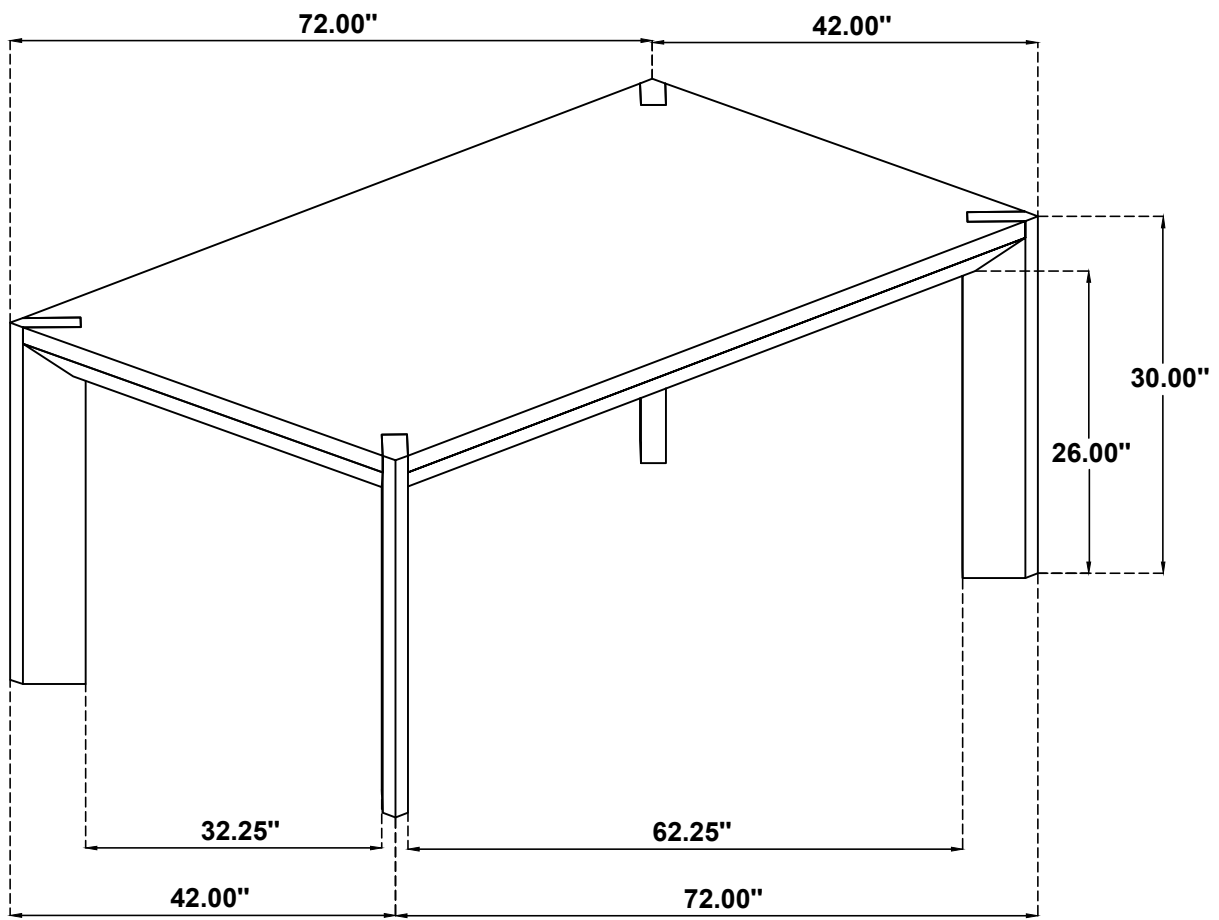

Note: Dimension tolerance $\pm 5\%$

ASSEMBLY INSTRUCTIONS



Fine Furniture for every stage of life

Side Chair

ASSEMBLY INSTRUCTIONS

ASSEMBLY TIPS:

1. Remove hardware from box and sort by size.
2. Please check to see that all hardware and parts are present prior to start of assembly.
3. Please follow attached instructions in the same sequence as numbered to assure fast & easy assembly.



WARNING!



1. Don't attempt to repair or modify parts that are broken or defective. Please contact the store immediately.
2. This product is for home use only and not intended for commercial establishments.







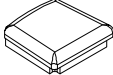

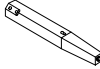
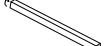
ASSEMBLY TIME

15 MINUTES

PARTS IDENTIFICATION

AN	BACK FRAME		1PC
BN	SEAT CUSHION WITH FRAME		1PC
CN	RIGHT FRONT LEG		1PC
DN	LEFT FRONT LEG		1PC
EN	SIDE STRETCHER		2PCS

HARDWARE IDENTIFICATION

1	ALLEN WRENCH (M4 x 59mm - BLK)		1PC
2	LONG BOLT (5/16" x 75mm - BLK)		4PCS
3	MEDIUM BOLT (5/16" x 63mm - BLK)		4PCS
4	SHORT BOLT (5/16" x 38mm - BLK)		2PCS
5	LOCK WASHER (5/16" - BLK)		10PCS
6	FLAT WASHER (5/16" - BLK)		10PCS
7	PAN HEAD SCREW (#8 x 40mm - BLK)		4PCS

NOTE:

Quantities shown are for one chair.

Phillips head screw driver is required in the assembly process. However, manufacturer does not provide this item.

ASSEMBLY INSTRUCTIONS

STEP 1

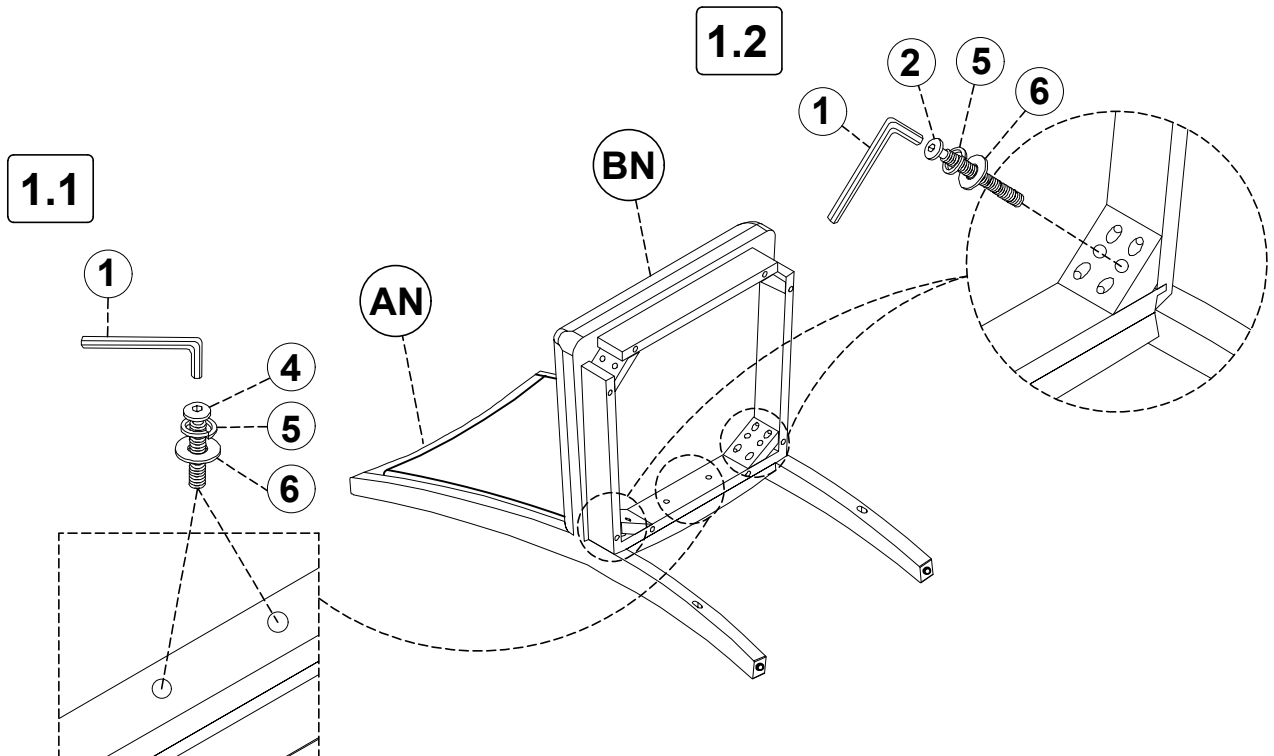

STEP 2

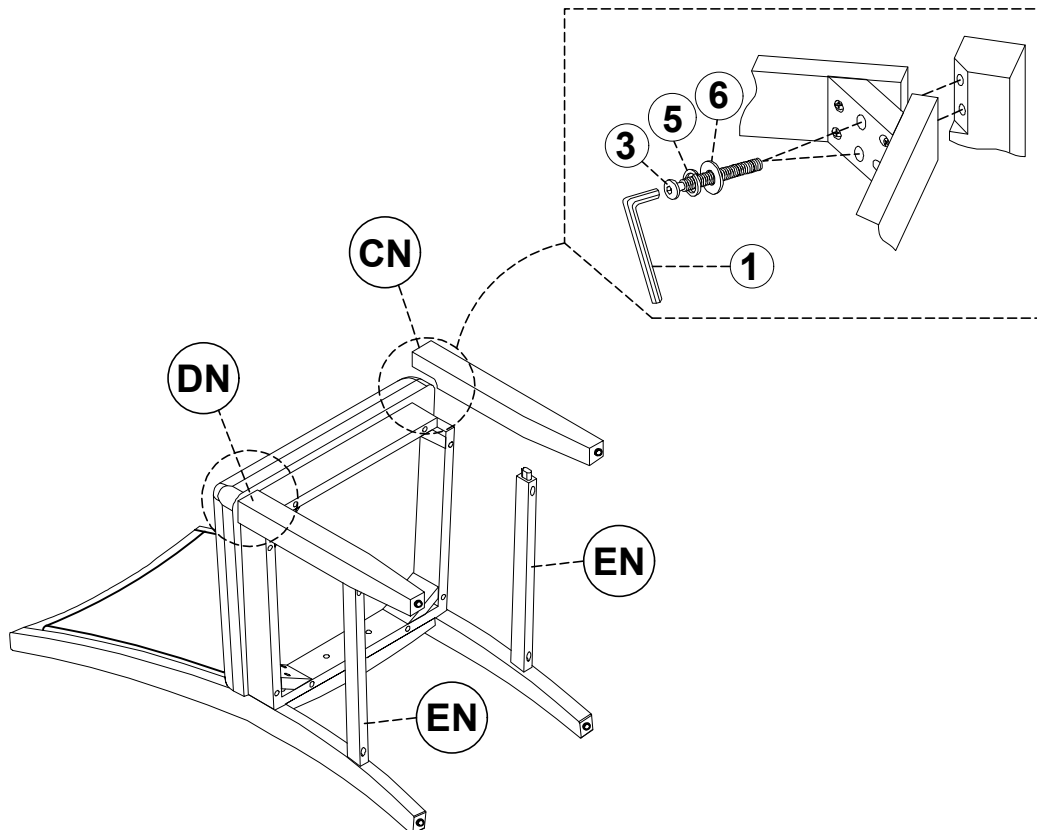

ASSEMBLY INSTRUCTIONS

STEP 3

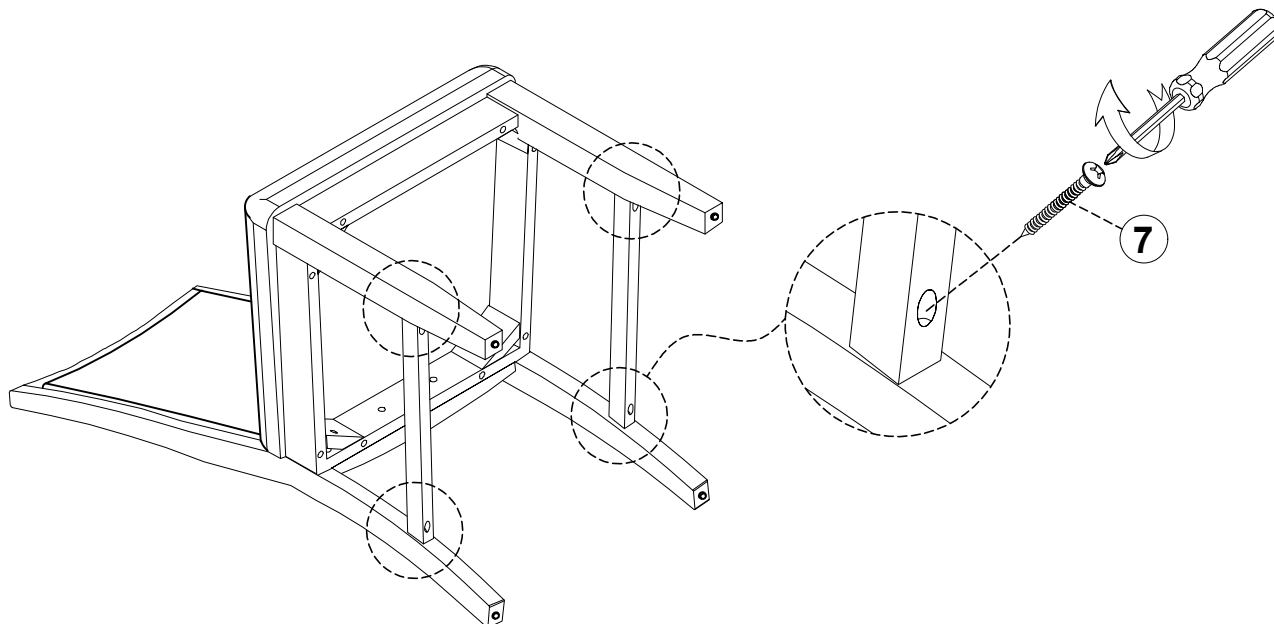

STEP 4 COMPLETE

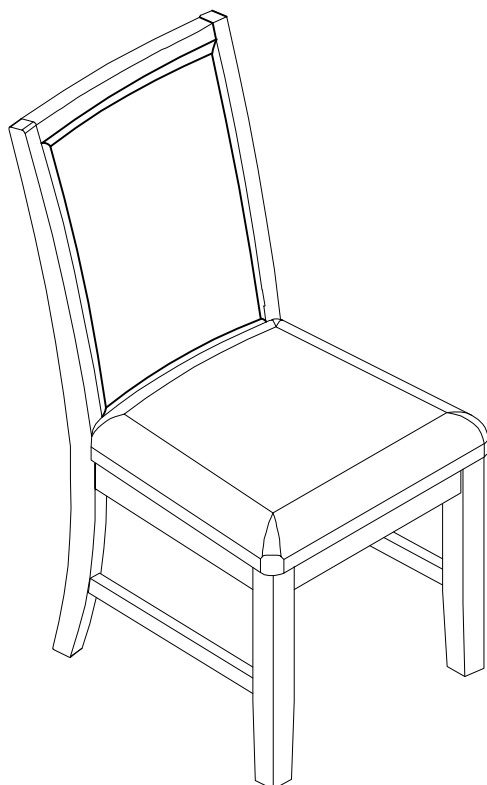

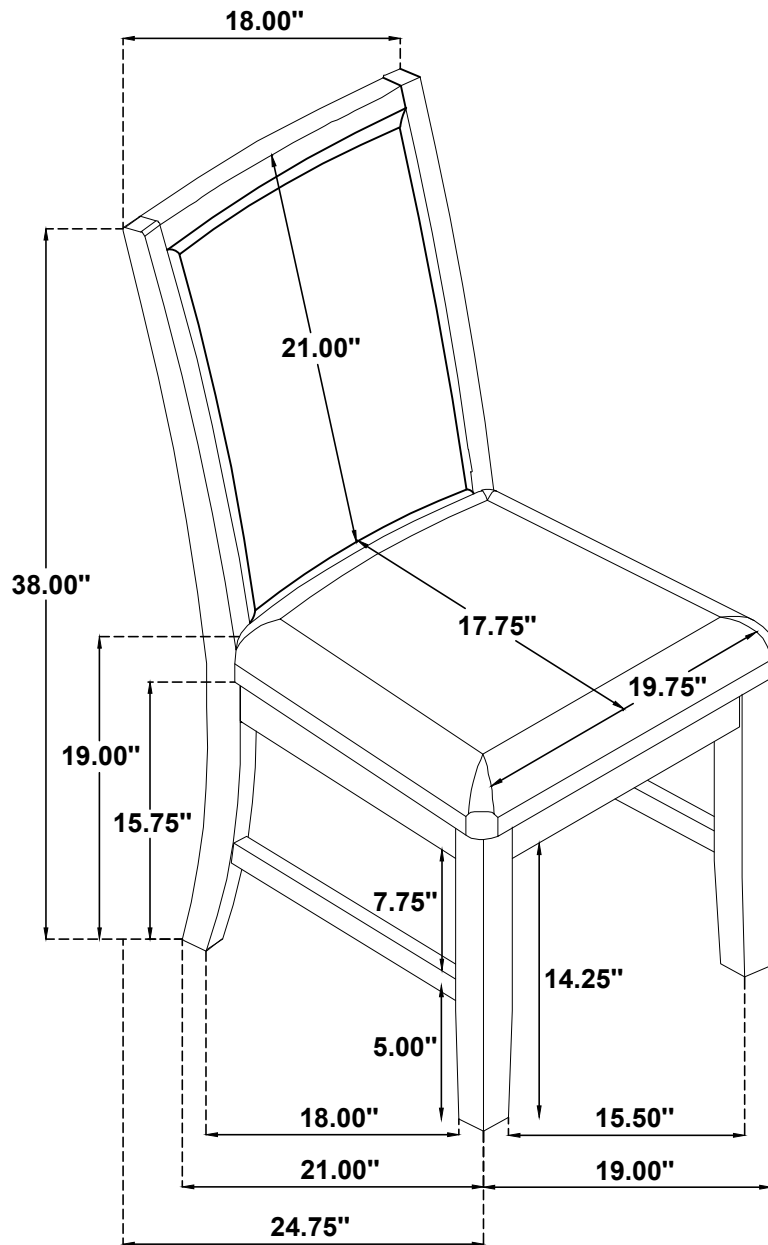

Note: Dimension tolerance $\pm 5\%$