

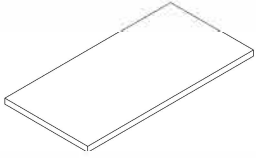

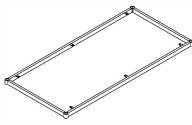

Kitchen Island

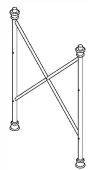
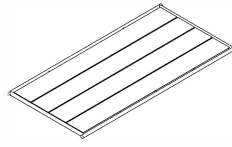
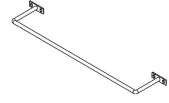

PART LIST

<p>A</p> 	<p>B</p> 	<p>C</p> 	<p>D</p> 	<p>E</p> 
<p>Marble Top 1 PC</p>	<p>Top Frame 1 PC</p>	<p>Side Panel 2 PCS</p>	<p>Shelf Panel 2 PCS</p>	<p>Hand Rail 2 PCS</p>

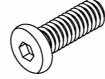
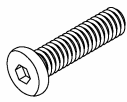
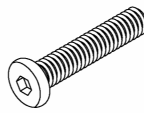
HARDWARE LIST

<p>#1</p> 	<p>#2</p> 	<p>#3</p> 	<p>#4</p> 	<p>#5</p> 
<p>1/4" x 1/2" L Short Bolt 8 PCS (Extra 1)</p>	<p>1/4" x 5/8" L Bolt 6 PCS (Extra 1)</p>	<p>1/4" x 1" L Medium Bolt 4 PCS (Extra 1)</p>	<p>1/4" x 1-1/2" L Long Bolt 8 PCS (Extra 1)</p>	<p>Allen Wrench 1 PC</p>

Step 1. Attach top frame (part B) to side panels (part C) using medium bolts (part #3) and allen wrench (part #5).

Note: Please do not fully tighten bolts at this time.

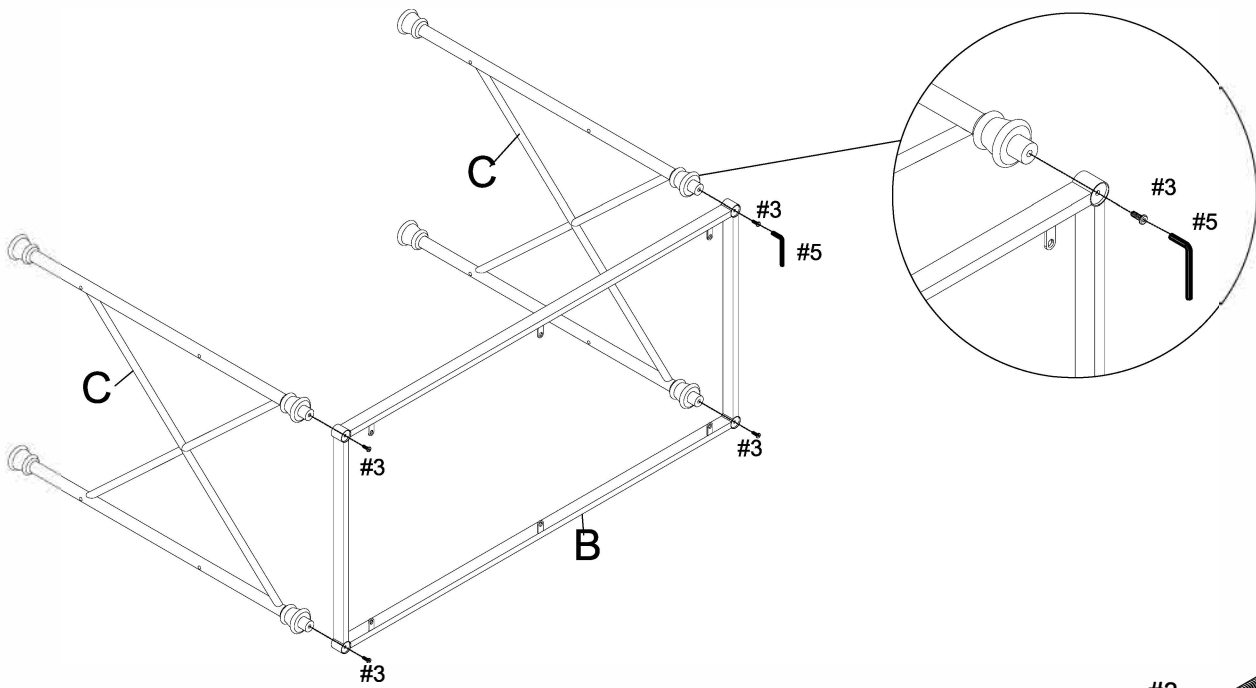

- #3  x 4
- #5  x 1

Step 2. Attach shelf panels (part D) to side panels (part C) using long bolts (part #4) and allen wrench (part #5).

Note: Please fully tighten all bolts at this time.

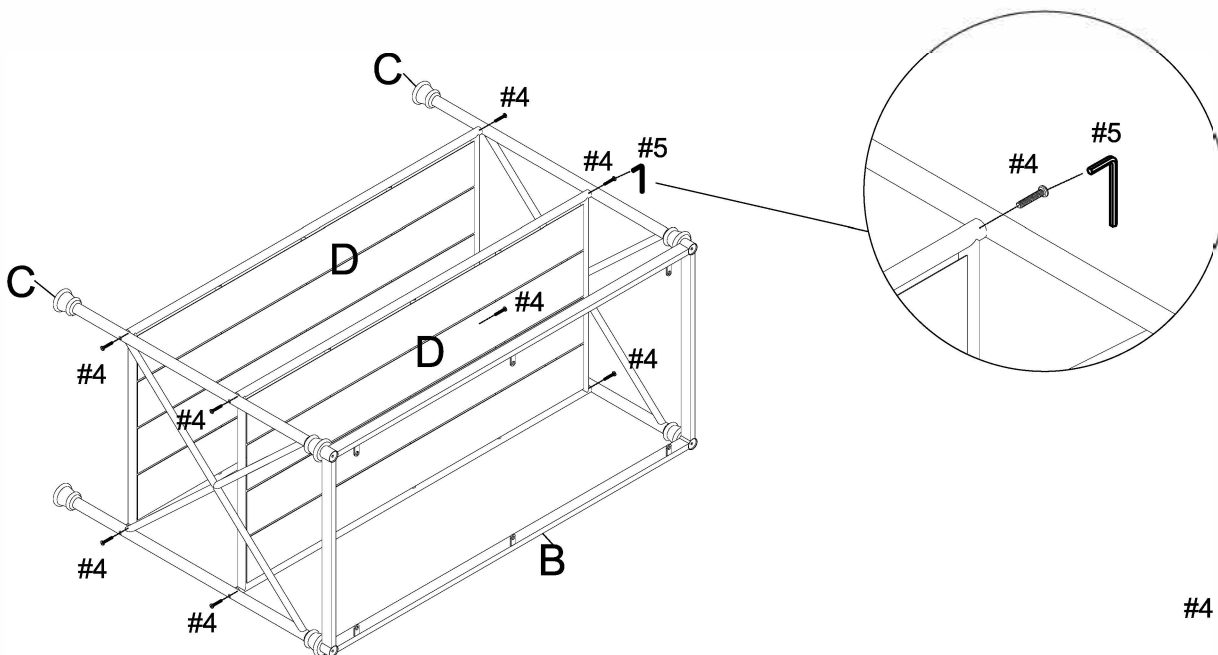

- #4  x 8
- #5  x 1

Step 3. Carefully lay marble top (part A) upside down on a flat, soft surface, such as carpet. Attach assembled unit (parts B, C & D) to marble top (part A) using bolts (part #2) and allen wrench (part #5).

Note: Please fully tighten all bolts at this time.

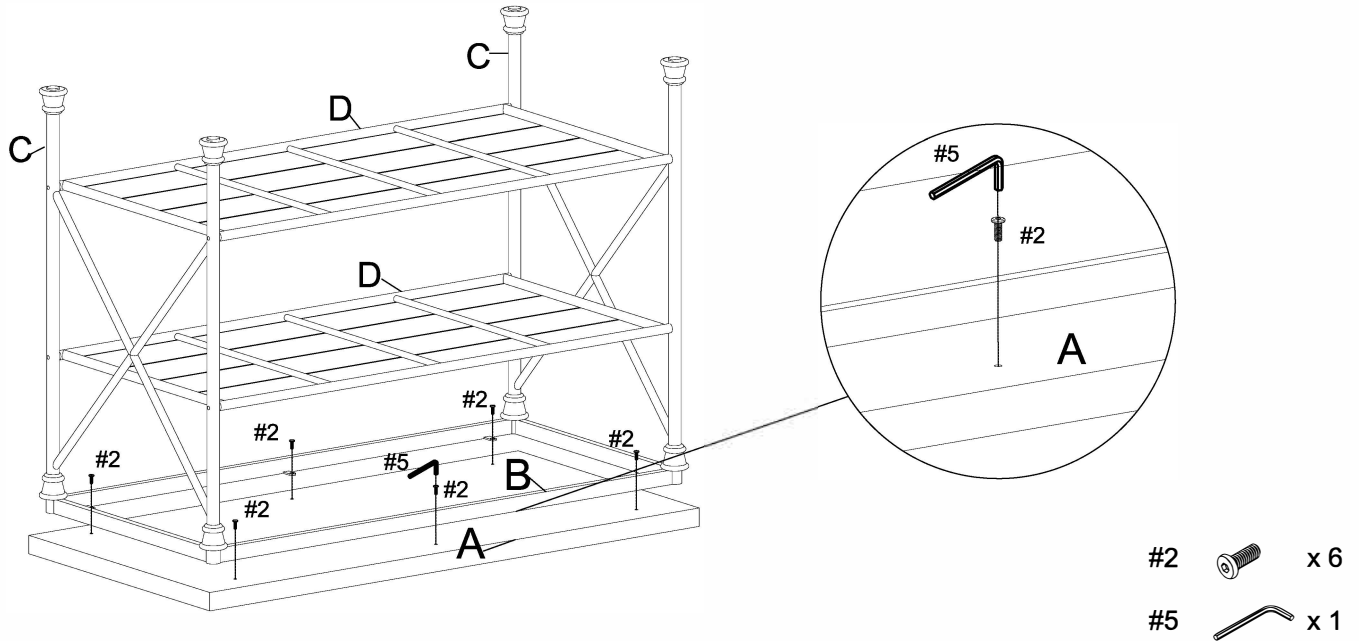

Step 4. Carefully turn unit upright. Attach hand rails (part E) to side panels (part C) using short bolts (part #1) and allen wrench (part #5).

Note: Please fully tighten all bolts at this time.

