

Bettwäsche mit Lichtstreifen Hängebett Linge de maison avec bande lumineuse lit suspendu

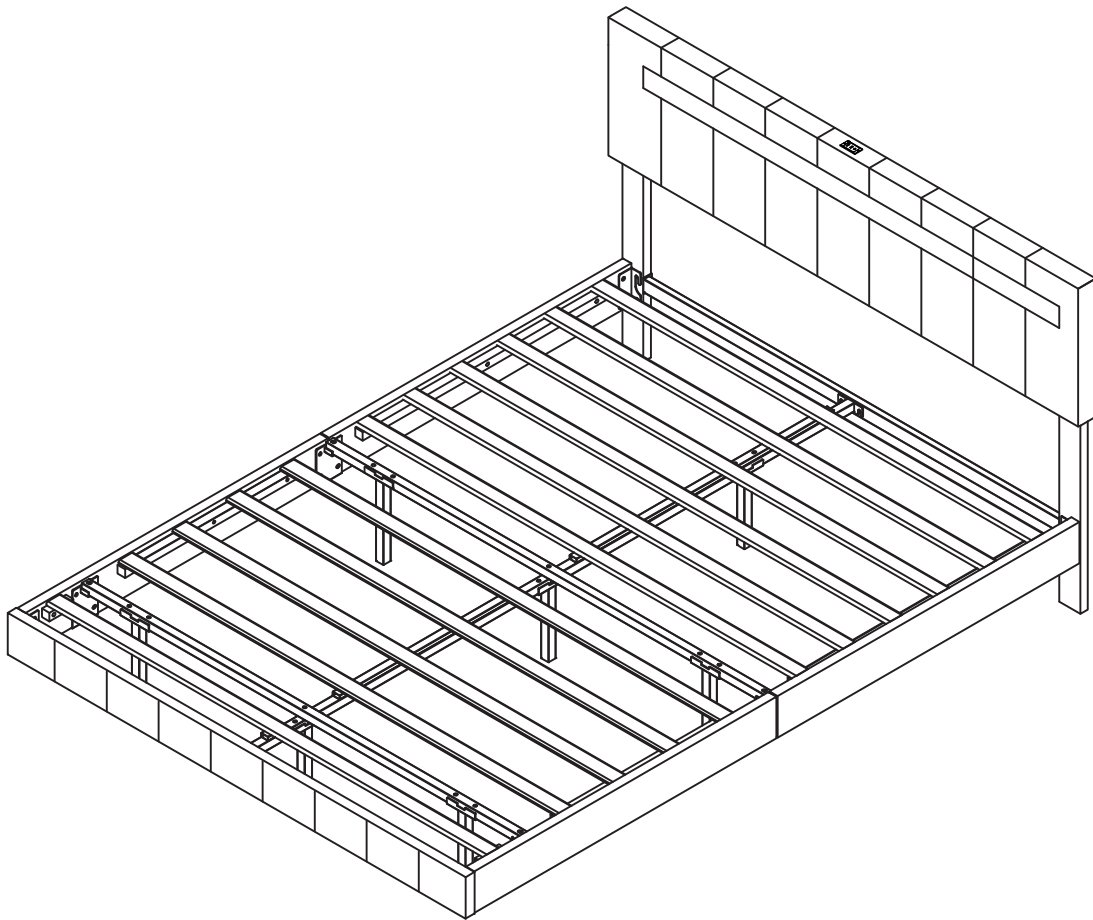

Freundlicher Kundenservice





Zufriedenheitsgarantien: Bei Problemen mit der Montage, der Qualität oder der Rückgabe können Sie sich gerne direkt an uns wenden.

Service client amical

Garanties de satisfaction : si vous rencontrez des problèmes d'assemblage, de qualité ou de retour, n'hésitez pas à nous contacter directement.

IMPORTANT/WICHTIG/ATENCION

IMPORTANT/IMPORTANTE

	<p>EN-We recommend 2 or more people to install. DE-Wir empfehlen, dass die Montage von 2 oder mehreren Personen durchgeführt werden sollte. ES-Recomendamos realizar el ensamble con 2 o más personas. FR -Il est recommandé d'effectuer le montage à 2 personne(s) ou plus. IT -È necessaria la presenza di 2 o più persone per il montaggio di questo prodotto.</p>
	<p>EN-The expected assembly time is 1 h. DE-Die Montagezeit beträgt durchschnittlich 1 h. ES-El tiempo aproximado de ensamble es de 1 h. FR-Le temps nécessaire est estimé à 1 h. IT-Il tempo previsto per il corretto assemblaggio è di 1 h.</p>
	<p>EN-Not intended for use by children. DE-Nicht geeignet für Kinder. ES-Producto no apto para niños. FR -Produit non destiné à être utilisé par des enfants. IT - Questo prodotto non è destinato all'uso da parte dei bambini.</p>
	<p>EN-Keep away from fire or other heat sources. DE-Bitte von Feuer und Hitzequellen fernhalten. ES -Manténgase alejado de las llamas y otras fuentes de calor. FR -Tenir à distance des flammes et autres sources de chaleur. IT -Tenere lontano dal fuoco o da altre fonti di calore.</p>
	<p>EN-We recommend wearing protective gloves.DE-Wirempfehlen das Tragen von Schutzhandschuhen.ES-Recomendamos el uso de guantes de seguridad.FR-Ilest recommandé de porter des gants de protection.IT-Per il processo di assemblaggio, consigliamo fortemente l'utilizzo di guanti protettivi.</p>

EN - Please follow the instruction manuals and use a pad to avoid damage during assembly.

DE - Bitte folgen Sie der Anleitung und verwenden Sie eine Unterlage, um Beschädigungen bei der Montage zu vermeiden.

ES - Por favor, siga las instrucciones del manual y utilice una cubierta o lona para proteger el producto y el suelo durante la instalación.



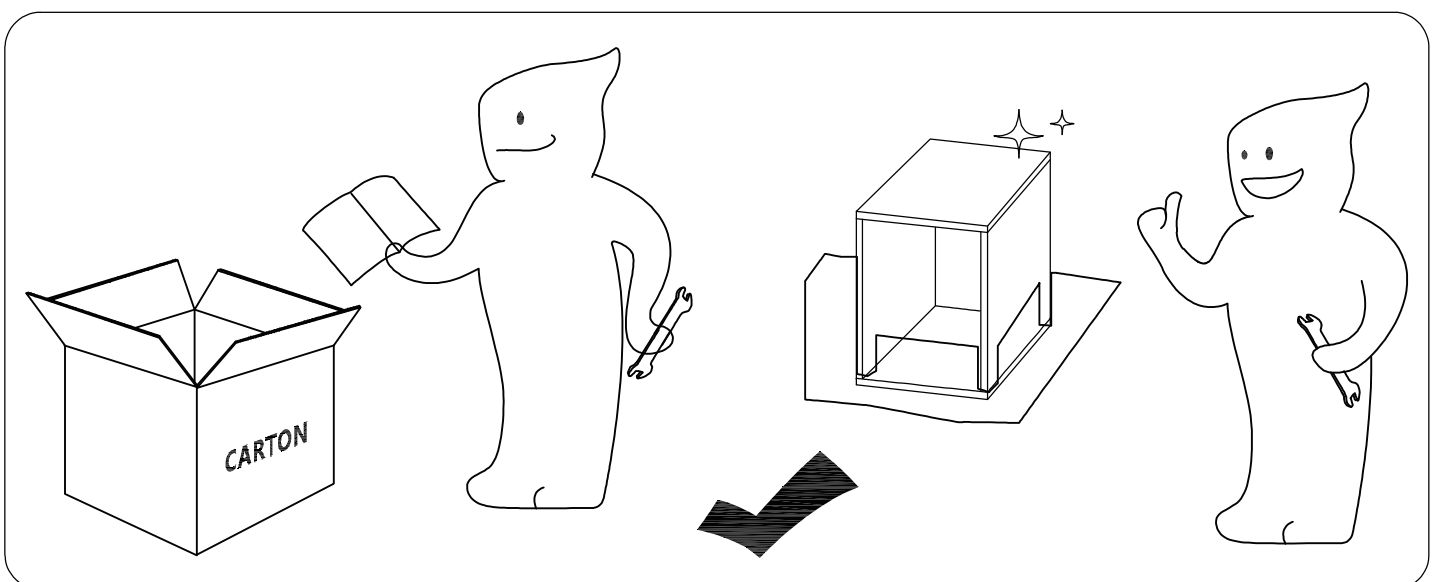
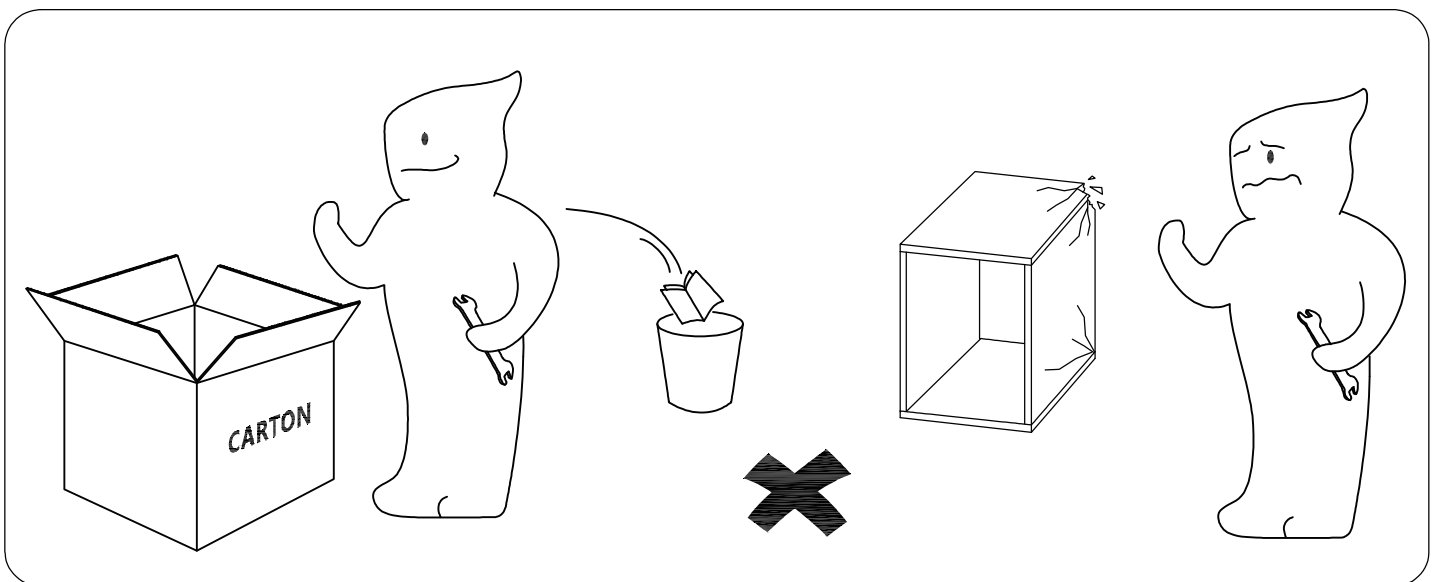

FR - Suivez les instructions de la notice et utilisez une couverture ou une bache pour protéger le produit et les sols pendant le montage.

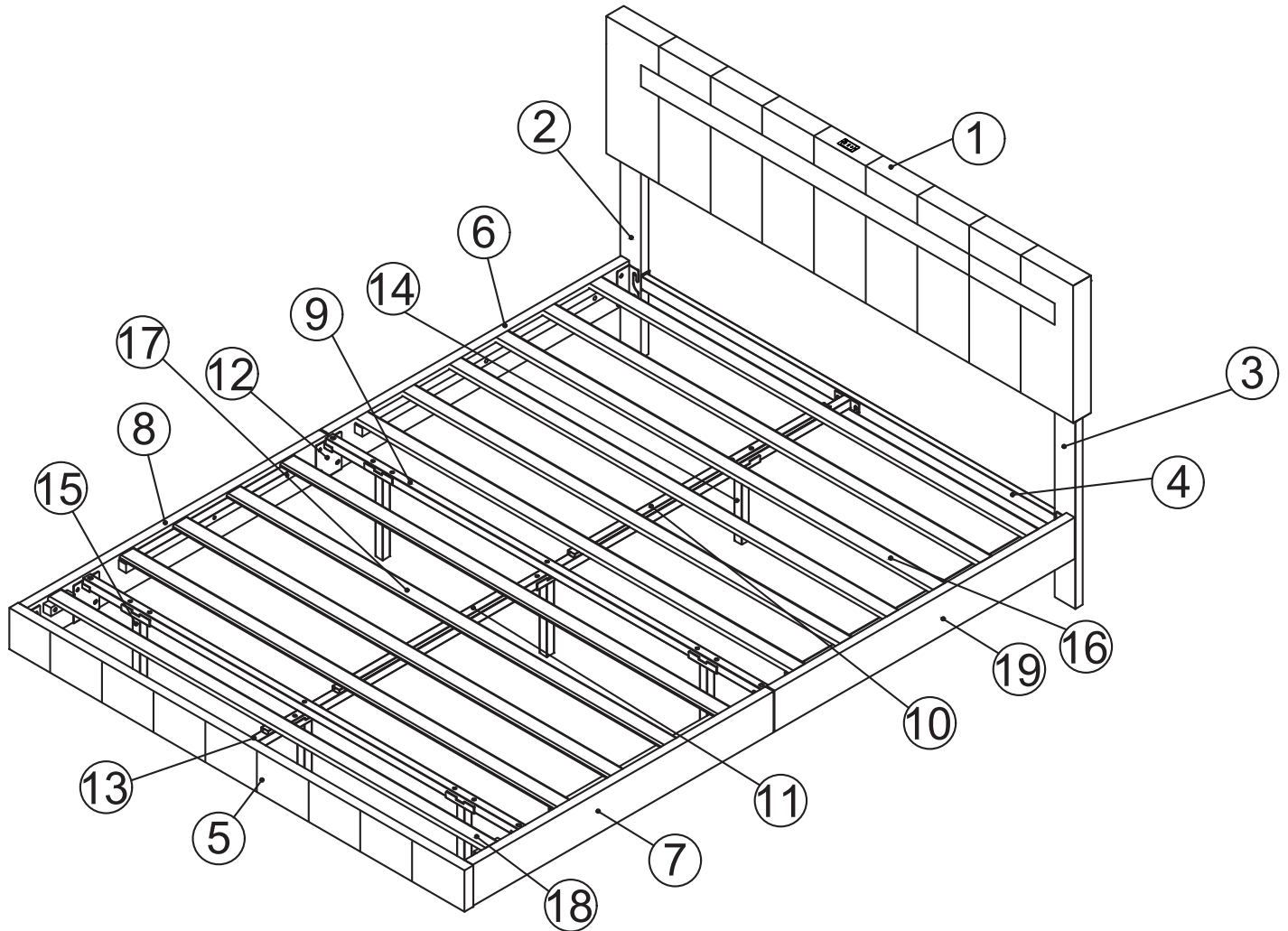
IT - Si prega di consultare il manuale illustrativo durante il montaggio e di utilizzare un cuscinetto per evitare possibili danni.











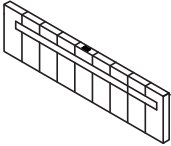

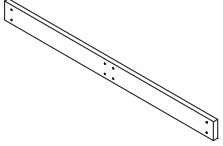
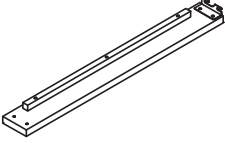
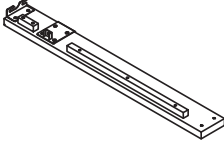
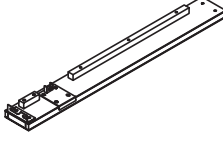
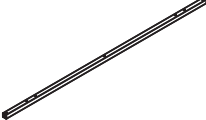
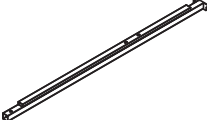
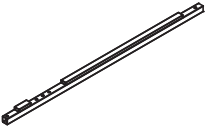
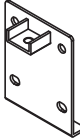

Hardware parts

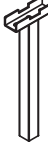
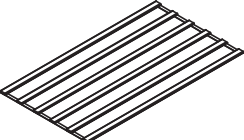
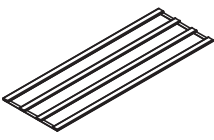
 (A) M8x 20 24pcs	 (B) M8x35 19pcs	 (C) M8x45 6pcs	 (D) M8x60 2pcs	 (E) 4 # 1pc
--	---	--	--	---

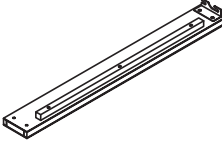
LISTE DER EINZELTEILE
LISTE D'OBJETS

 ① 1 PC	 ② 1 PC	 ③ 1 PC	 ④ 1 PC	 ⑤ 1 PC
 ⑥ 1 PC	 ⑦ 1 PC	 ⑧ 1 PC	 ⑨ 2 PCS	 ⑩ 1 PC
 ⑪ 1 PC	 ⑫ 2 PCS	 ⑬ 1 PC	 ⑭ 3 PCS	 ⑮ 4 PCS
 ⑯ 1 PC	 ⑰ 1 PC	 ⑱ 1 PC	 ⑲ 1 PC	 LED ⑳ 1 PC

1

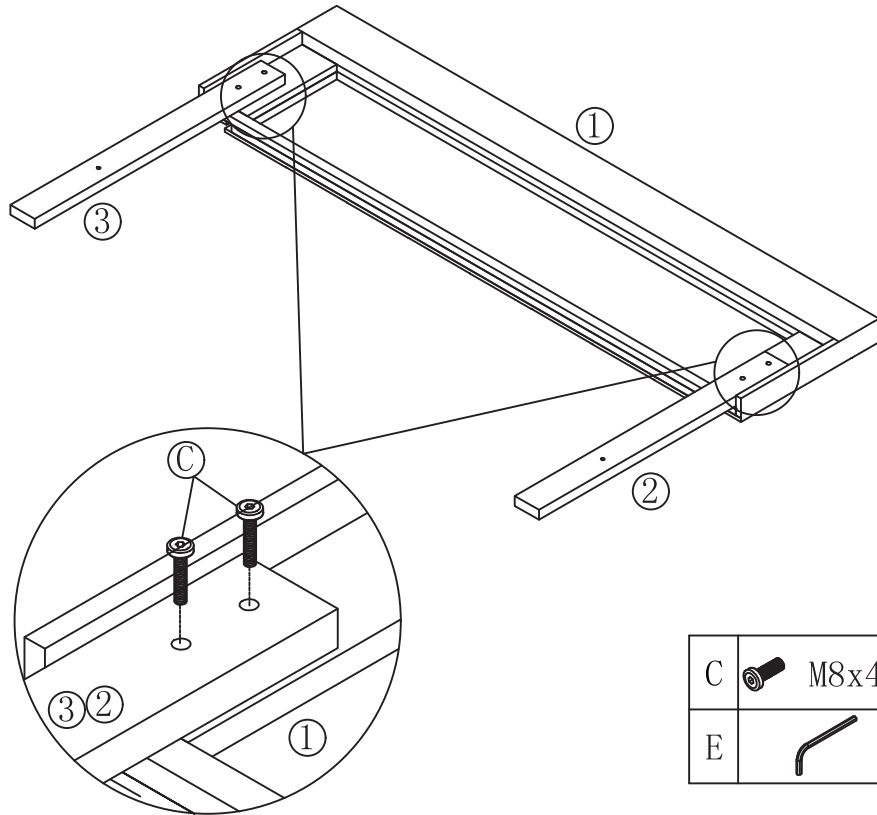

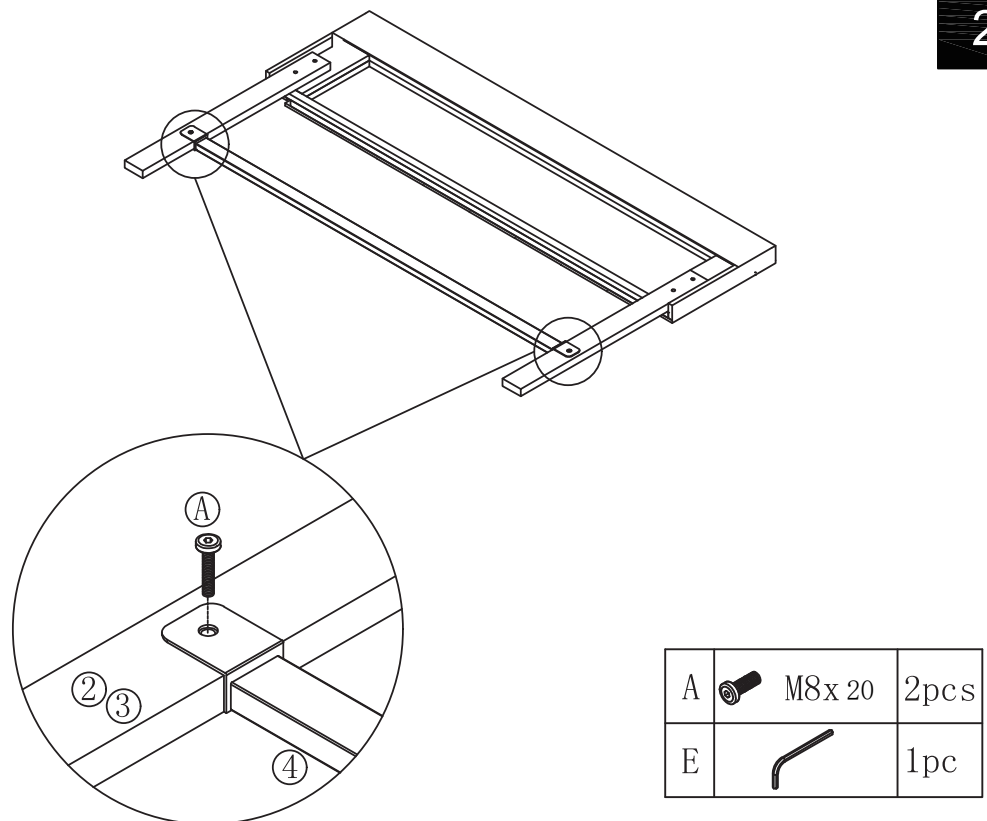

2



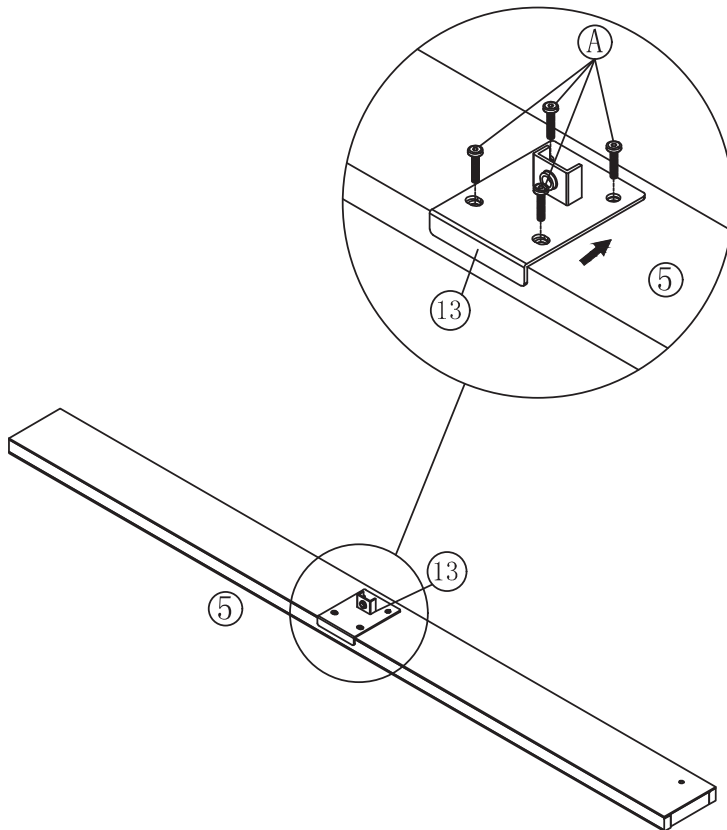

3



A		M8x20	4pcs
E			1pc

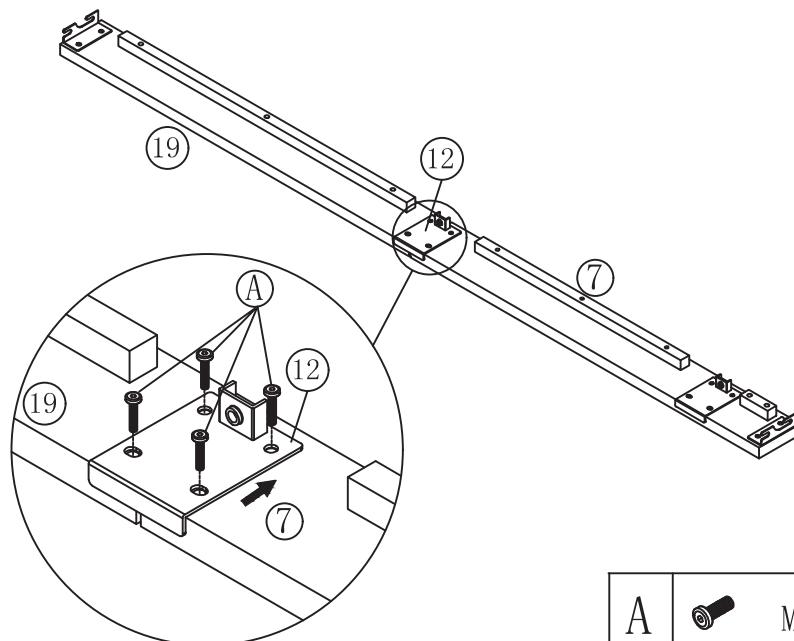

4



A		M8x 20	4pcs
E			1pc

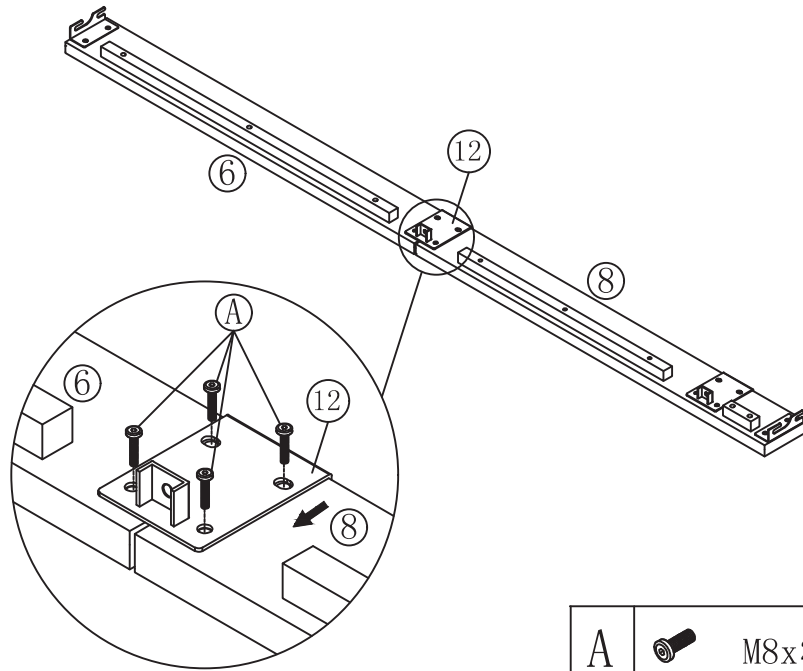

5



A		M8x20	4pcs
E			1pc

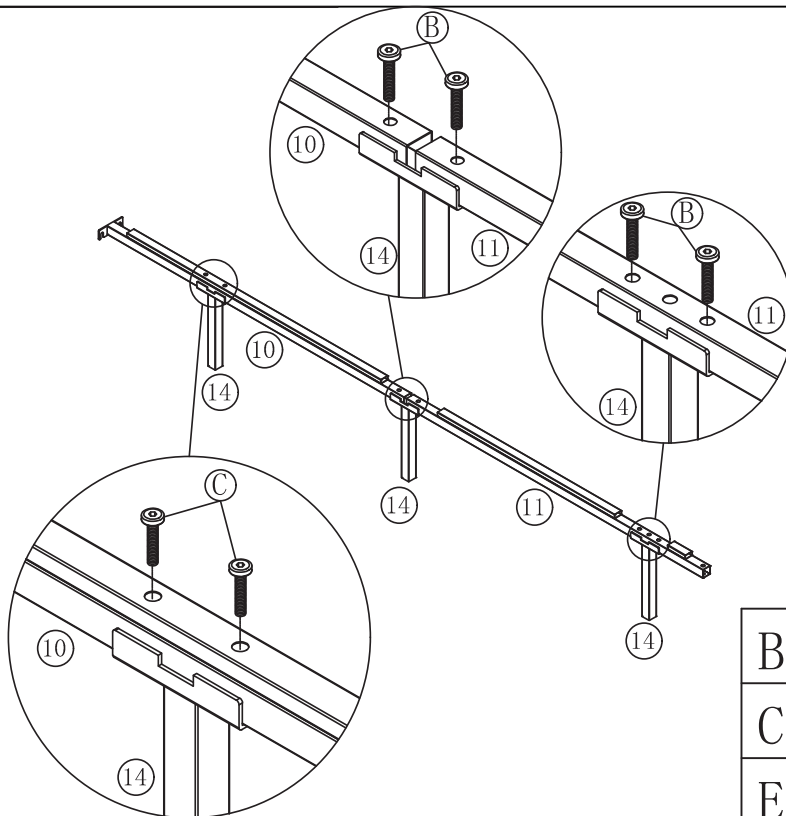

6



B		M8x35	4pcs
C		M8x45	2pcs
E			1pc

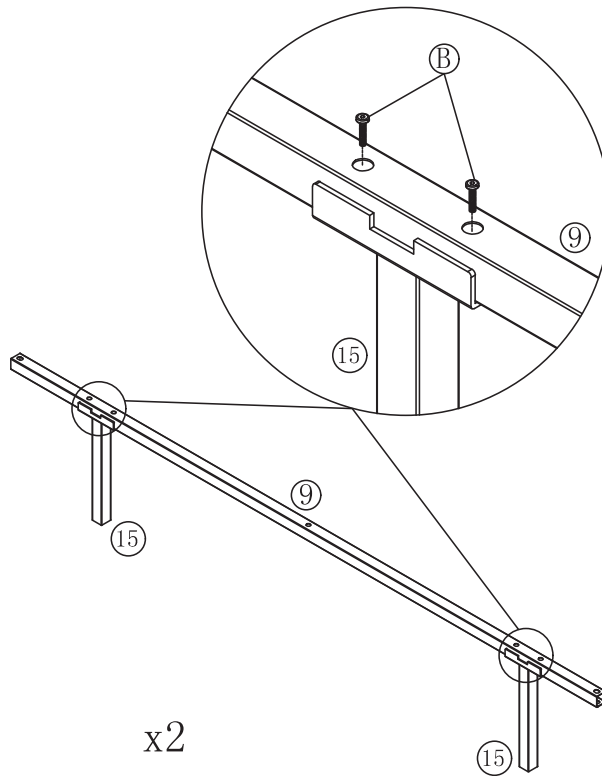

7

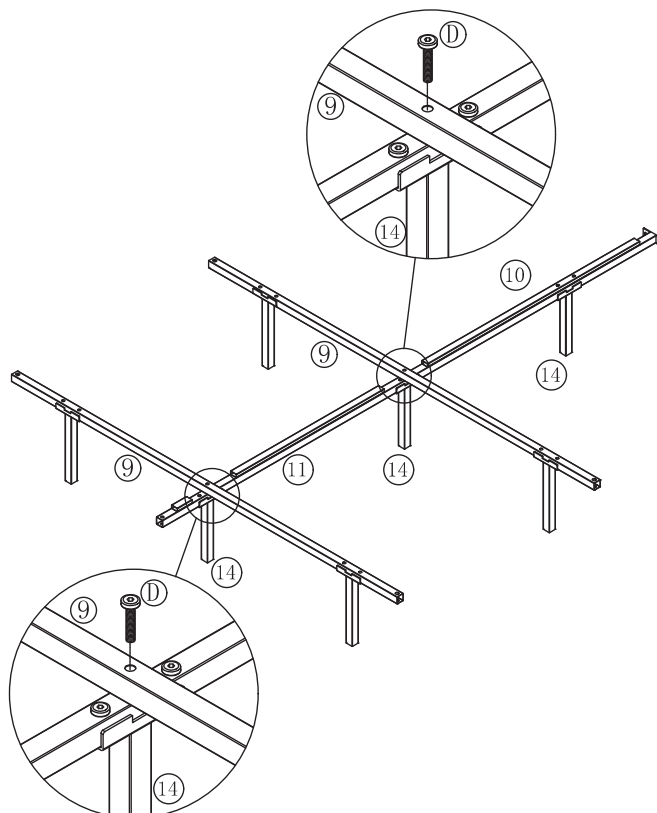

B		M8x35	8pcs
E			1pc

8



D		M8x60	2pcs
E			1pc

9

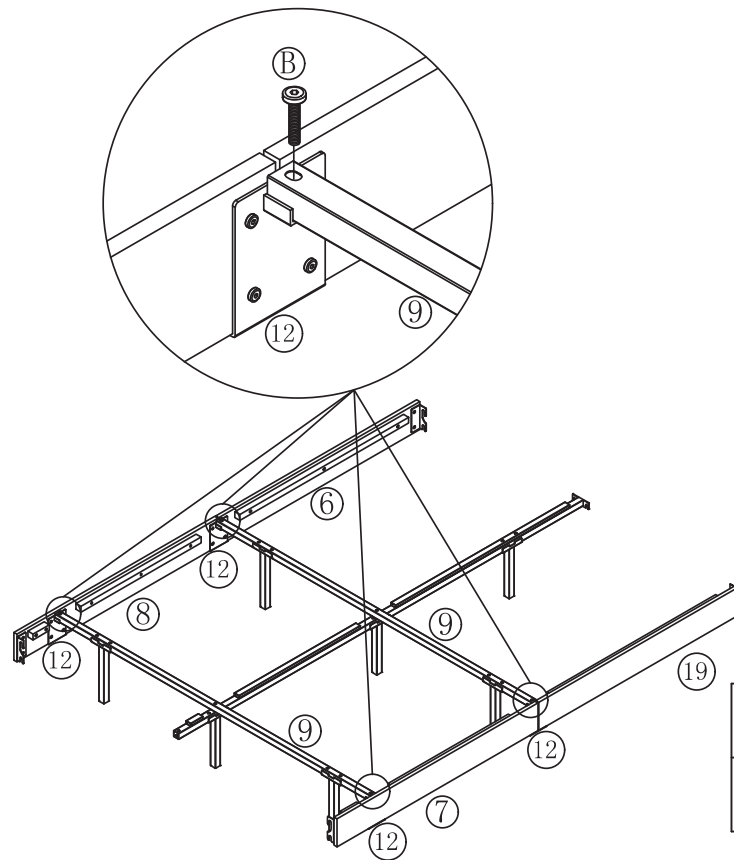

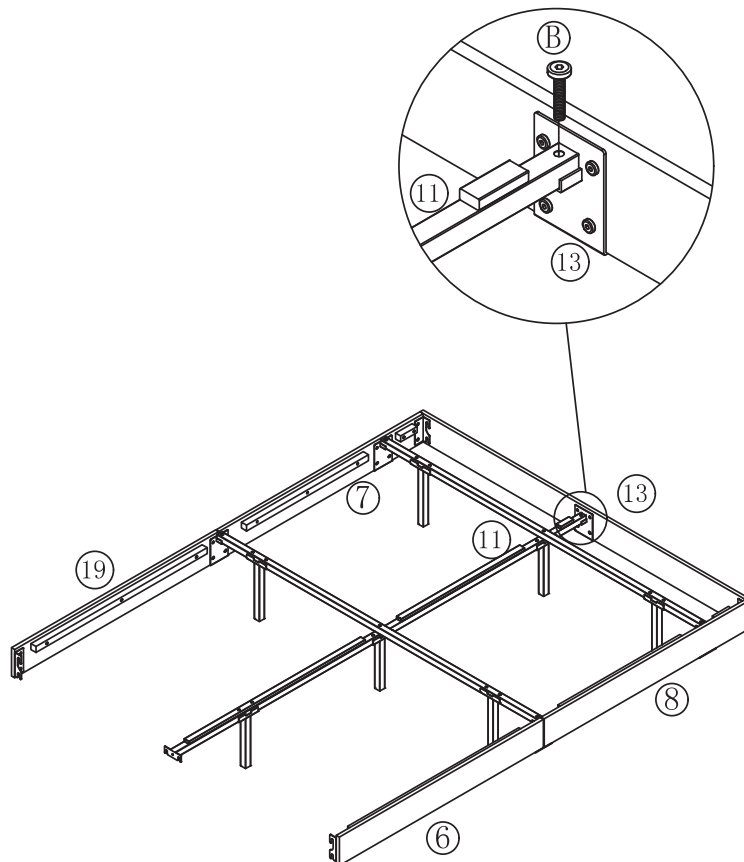

10



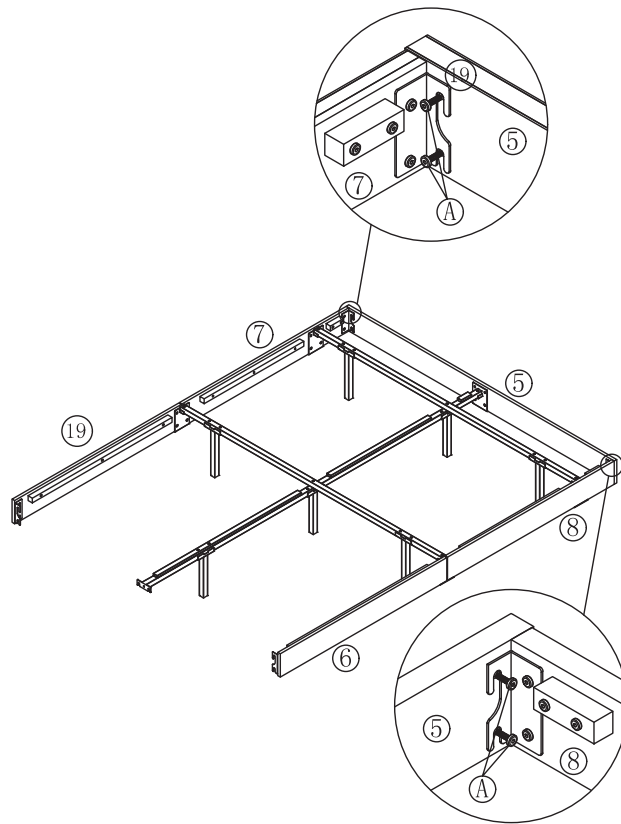

11

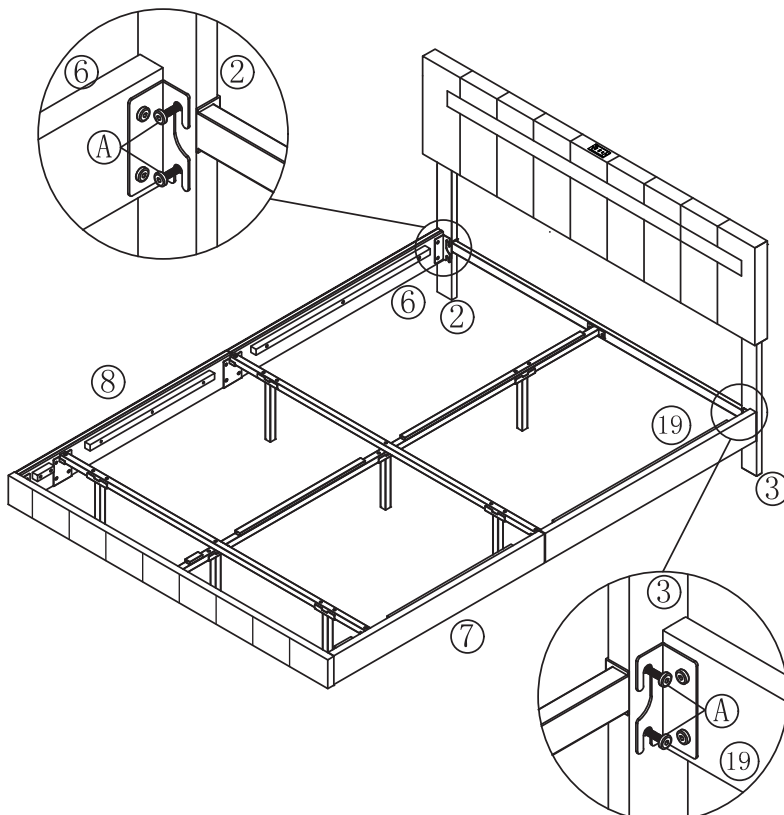

A		M8x20	4pcs
E			1pc

12



A		M8x20	4pcs
E			1pc

13

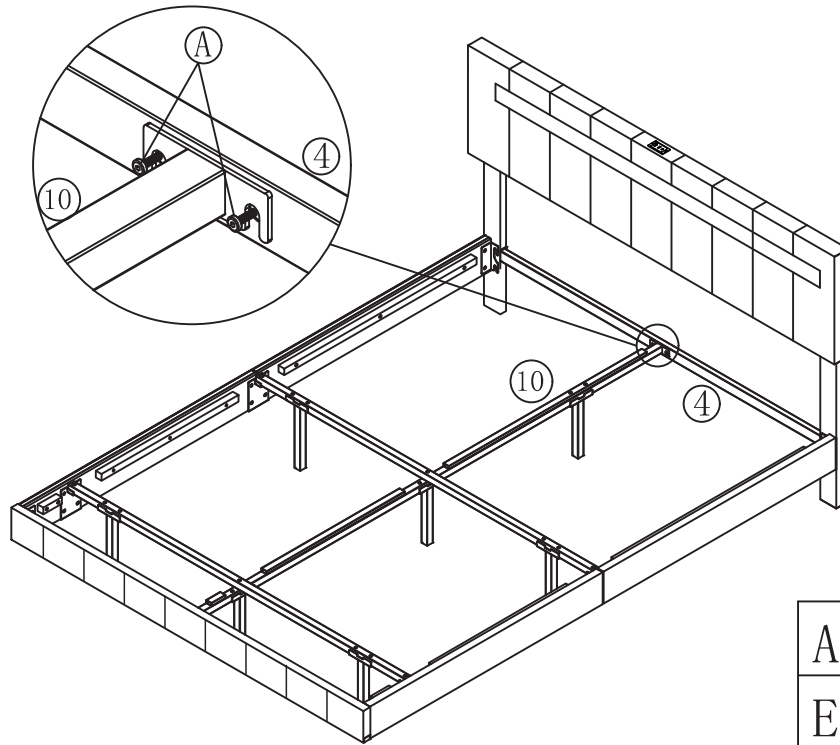

14

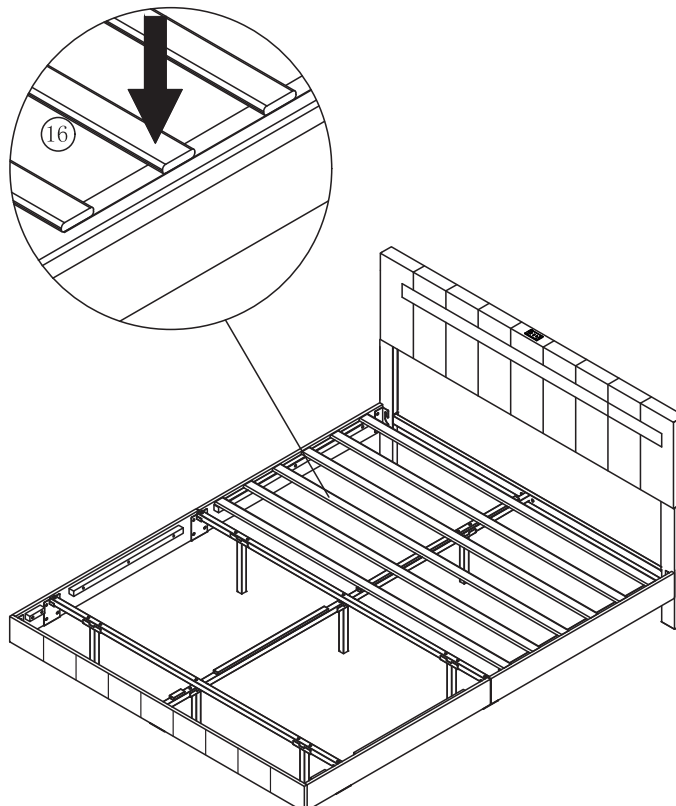

15

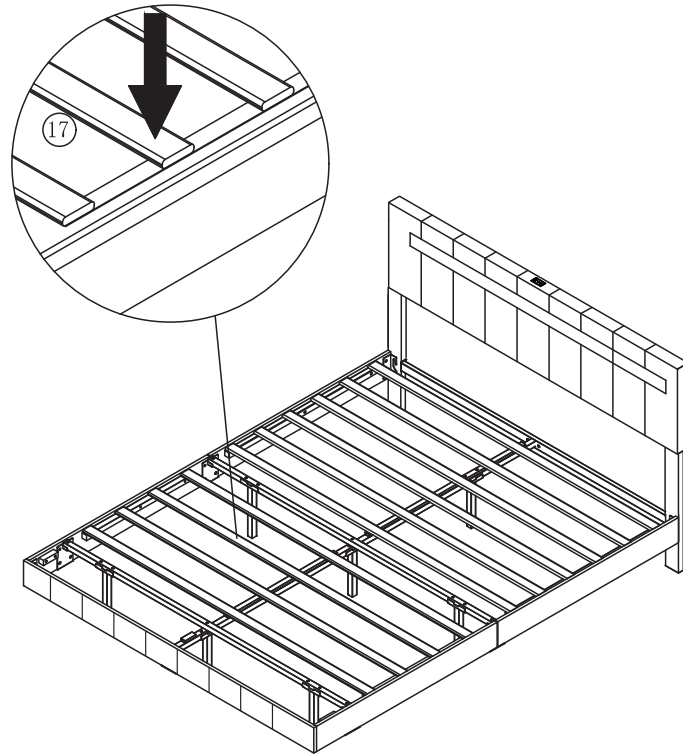

16

