

# ASSEMBLY INSTRUCTION

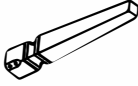



## DESCRIPTION : BENCH

Thank you for purchasing this quality product. Be sure to check all packing material carefully for small parts which may have loose inside the carton during shipment. Identify and count all parts and compare with the parts list below.

### PART LIST#

NO	NAME	PART	QTY
A	Bench		1pc
B	Leg		4pcs

### HARDWARE LIST

NO	NAME	PART	QTY
1	Allen Key		1pc
2	JCBB M8 x 60mm		8pcs
3	M8 " Spring Washer		8pcs
4	5/16" Flat Washer		8pcs

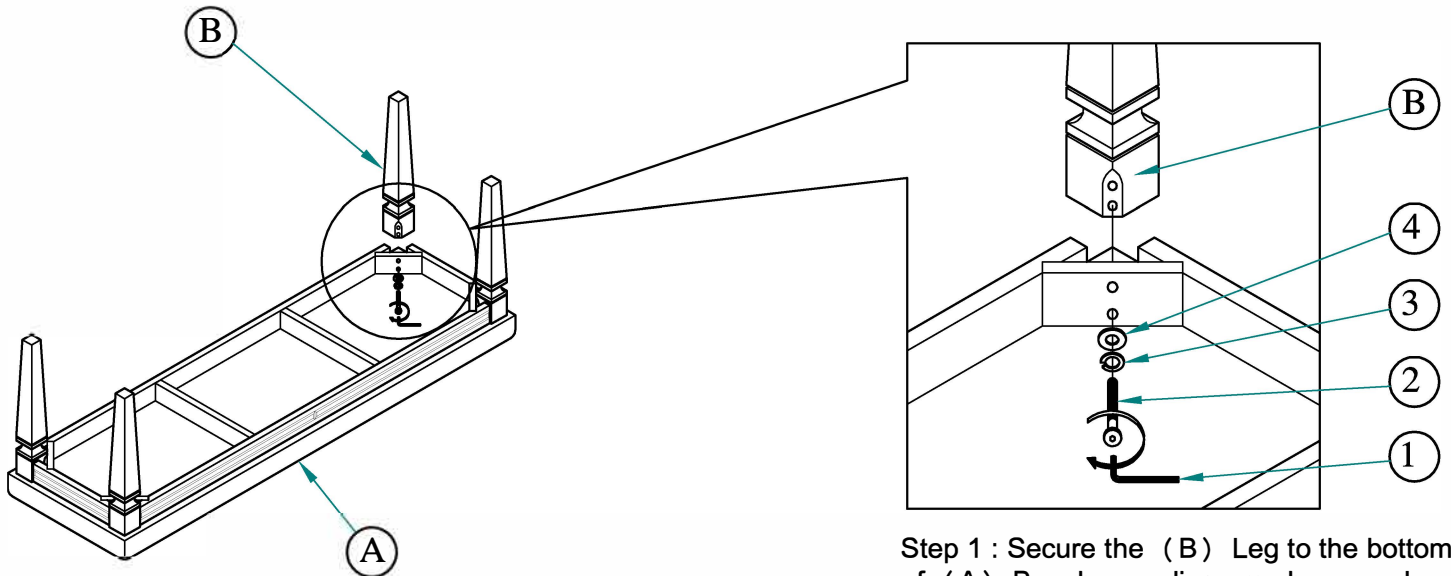

Step 1 : Secure the ( B ) Leg to the bottom of ( A ) Bench as a diagram shown and tighten with ( 2 ) JCBB M8 x 60mm, ( 3 ) M8 Spring Washer & ( 4 ) 5/16" Flat Washer.

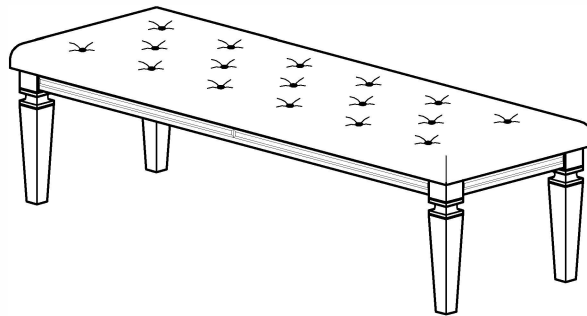

Assembly completed