

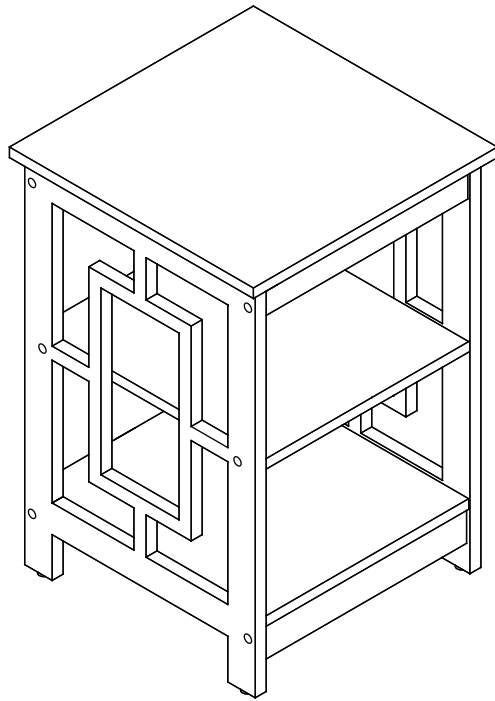



END TABLE

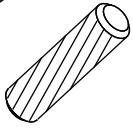
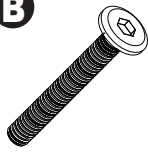

ASSEMBLY INSTRUCTIONS

We have designed our furniture with you , the customer in mind . Our clear , easy to follow , step by step instructions will guide you through the project from start to finish . Feel confident that this will be a fun and rewarding project . The final product will be a quality piece of furniture that will go together smoothly and give years of enjoyment .

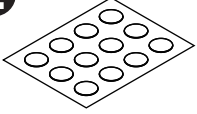
Hardware List

A 	B 	C 	D 	E 
Wood Dowel(12pcs)	Allen Bolt(12pcs)	LOCK Nut(12pcs)	Cam Bolt (8pcs)	Stickers (12pcs)
F 	G 			
Cam Lock (8pc)	Allen Wrench (1pc)			Glue : For securing please apply to wood dowel first before inserting into panel .

Panel List

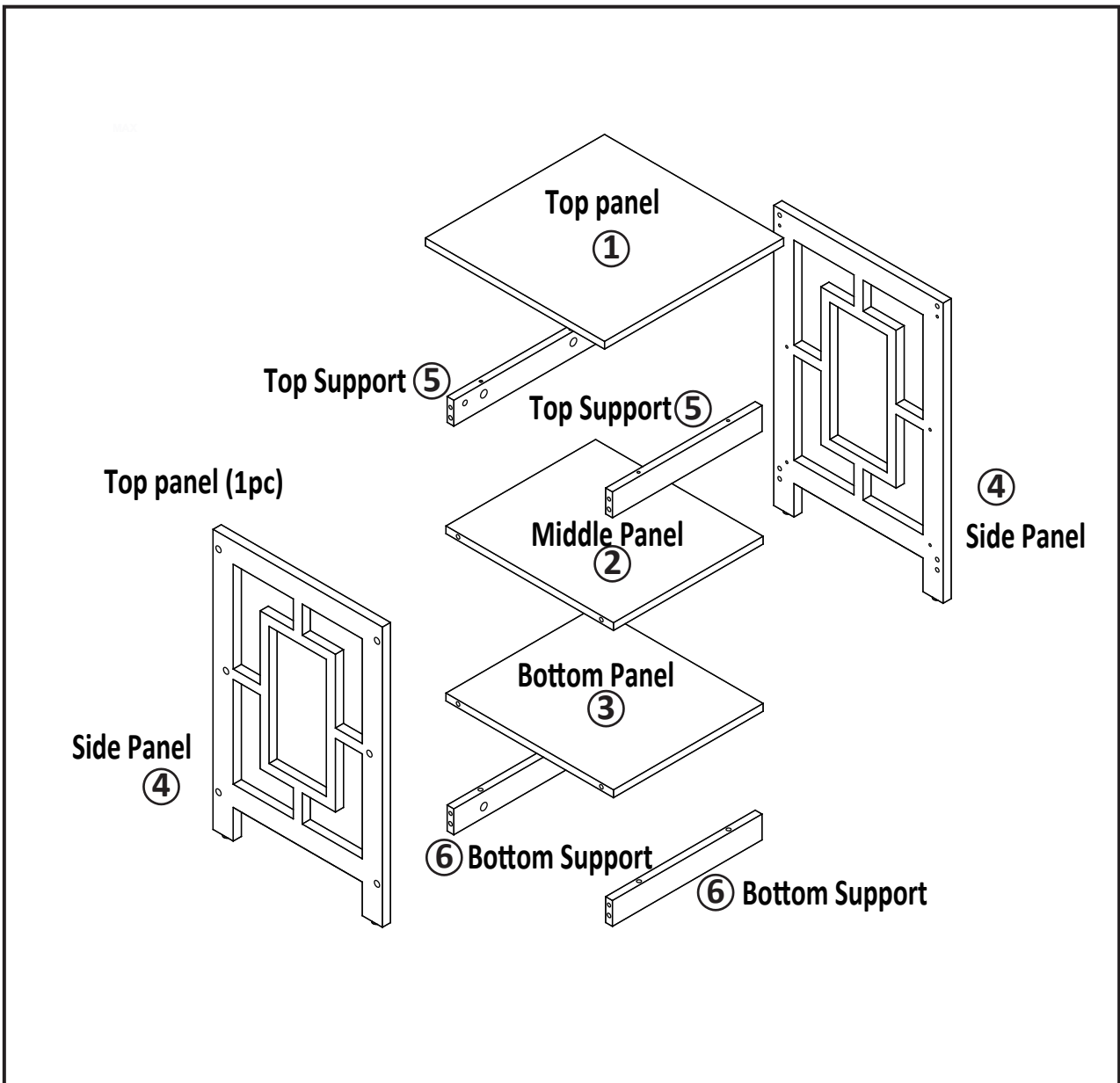

Please count and verify all parts before assembly .

Assembling the unit with camlocks and wood dowels.

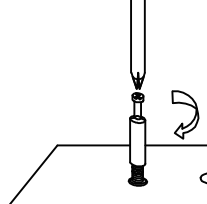
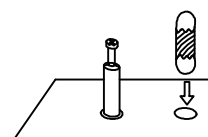
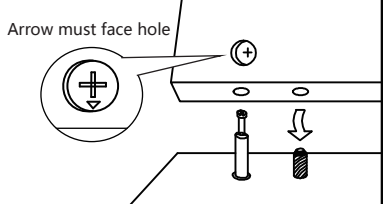
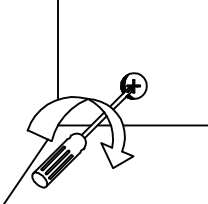
			
<p>Gently screw cambolt into the threaded anchor.</p>	<p>Lightly glue one end of the wood dowel and tap halfway into hole.</p>	<p>Lightly glue wood dowel and connect to second panel by inserting dowels into holes.</p>	<p>Screw the camlock firmly into locked position.</p>

Step 1

1. Screw Cambolts (D) into Top Panel ① and Bottom Panel ③ as shown.
2. Gently tap Wood Dowels (A) into Top Supports ⑤ and Bottom Supports ⑥ .

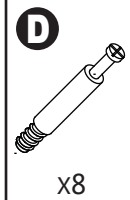
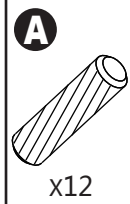
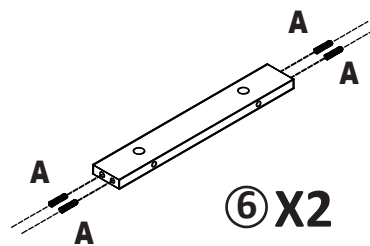
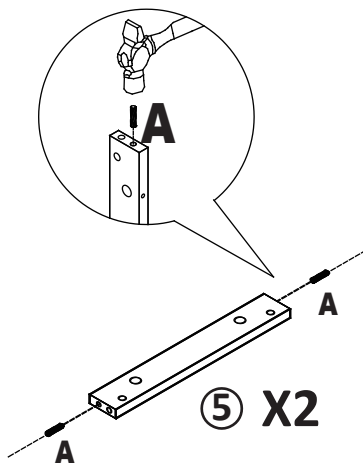
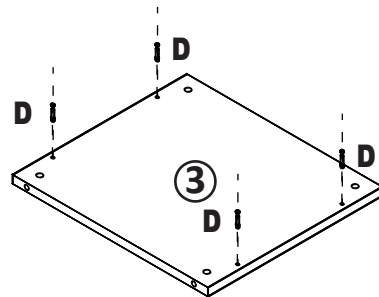
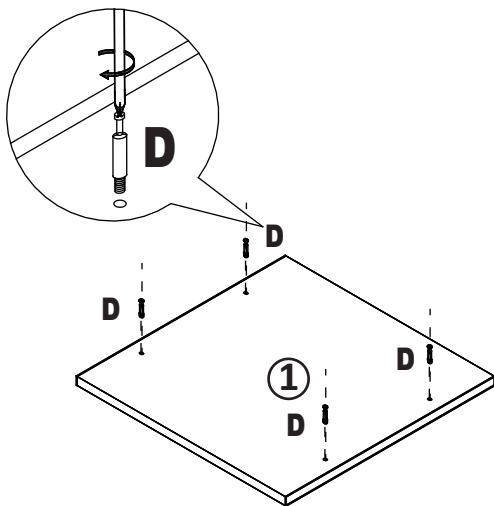

Step 2

*Assemble unit on carpet or flat surface.

1. Insert Cam Locks (F) into Top Support Bars (5).
2. Connect Top Support Bars (5) to Top Panel (1) by gently tightening Cam Locks (F).
3. Insert Cam Locks (F) into Bottom Support Bars (6).
4. Connect Bottom Support Bars (6) to Bottom Panel (3) by gently tightening Cam Locks (F).

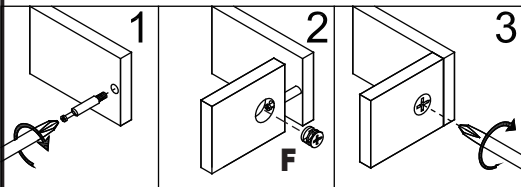
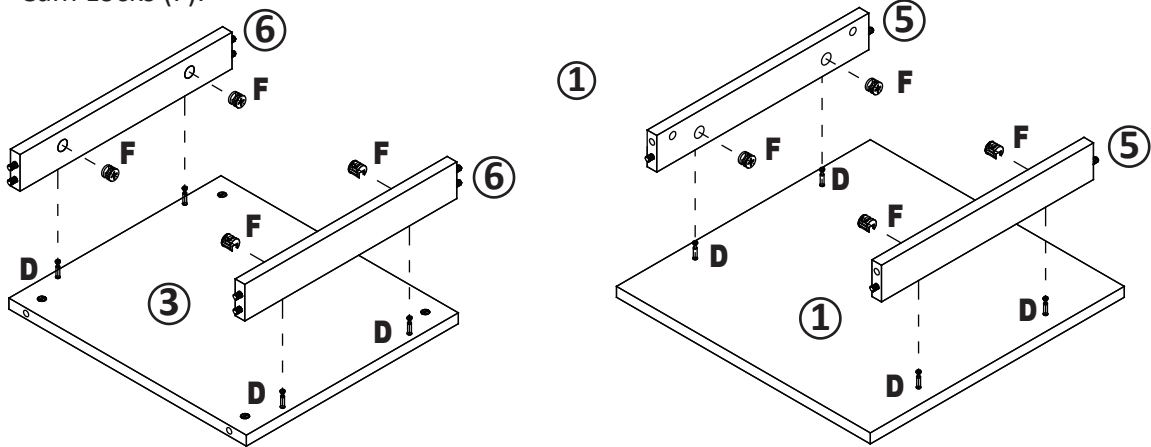

Step 3

1. Carefully connect Side Panel (4) to Top (1), middle (2), and Bottom Panels (3) using Bolts (B) and Lock Nuts (C).

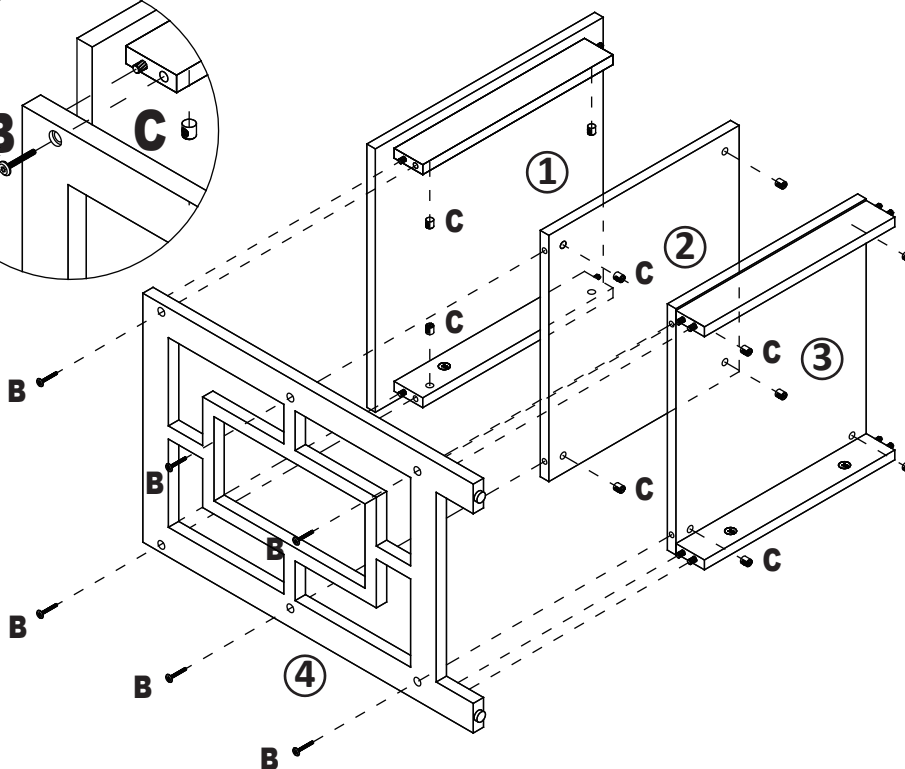
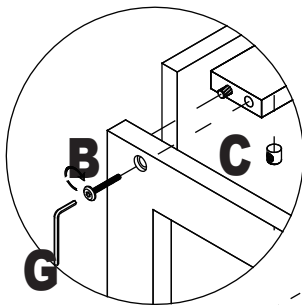

Step 4

1.Repeat Step 3 using Side Panel ④.

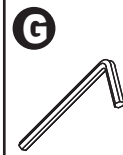
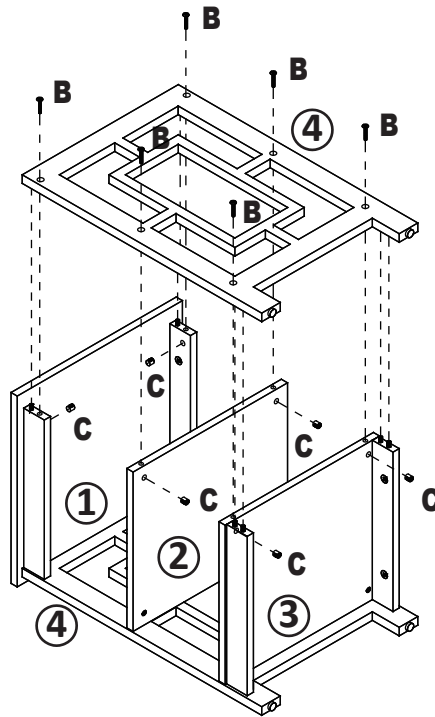
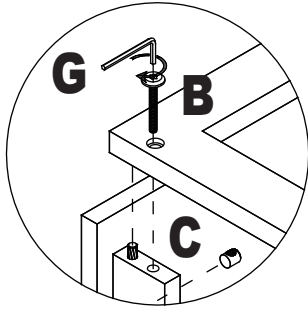

Step 5

- 1.If desired ,place Stickers (E) over screw holes.
- 2.Enjoy.

