

Read this instruction carefully. See hardware and furniture part list for guidance. Be sure all parts are complete, before you assemble. Place all wooden furniture parts on a clean and flat soft surface to prevent from being scratched. Follow the figure to start assembling.

CAUTIONS : 1. Do not FULLY - TIGHTEN the nut or nut bolt until all nut or bolt is ready assembled.
 2. Do not OVER - TIGHTEN the nut or bolt to avoid causing damages to the thread.
 3. Keep all hardware parts out of reach of children.

NOTE : THE LIST AND QUANTITY SHOWN ARE FOR 1 UNIT ASSEMBLY.

Tool needed : Screwdriver (not provider).

PART LIST			
ITEM	DESCRIPTION	BOX	QTY
A	HEADBOARD	1	1 PC
B	HEADBOARD LEG	4	2 PCS
C	FOOTBOARD	2	1 PC
D	FOOTBOARD LEG	4	2 PCS
E	SIDE RAIL	2	2 PCS
F	SIDE RAIL SUPPORT WOOD	2	2 PCS
G	CENTER RAIL	2	1 PC
H	CENTER SUPPORT LEG	2	3 PCS
I	BED SLAT	3	1 SET

HARDWARE LIST (BOX : 2)		
ITEM	DESCRIPTION	QTY
1	JCBC BOLT M6 x 40mm	22 PCS
2	M6 FLAT WASHER	14 PCS
3	M6 SPRING WASHER	14 PCS
4	WOOD SCREW M4 x 38mm	9 PCS
5	WOOD SCREW M4 x 20mm	2 PCS
6	WOOD DOWEL M8 x 30mm	12 PCS
7	M4 ALLEN KEY (BALL SHAPE)	1 PC
8	M5 ALLEN KEY (BALL SHAPE)	1 PC

STEP 1

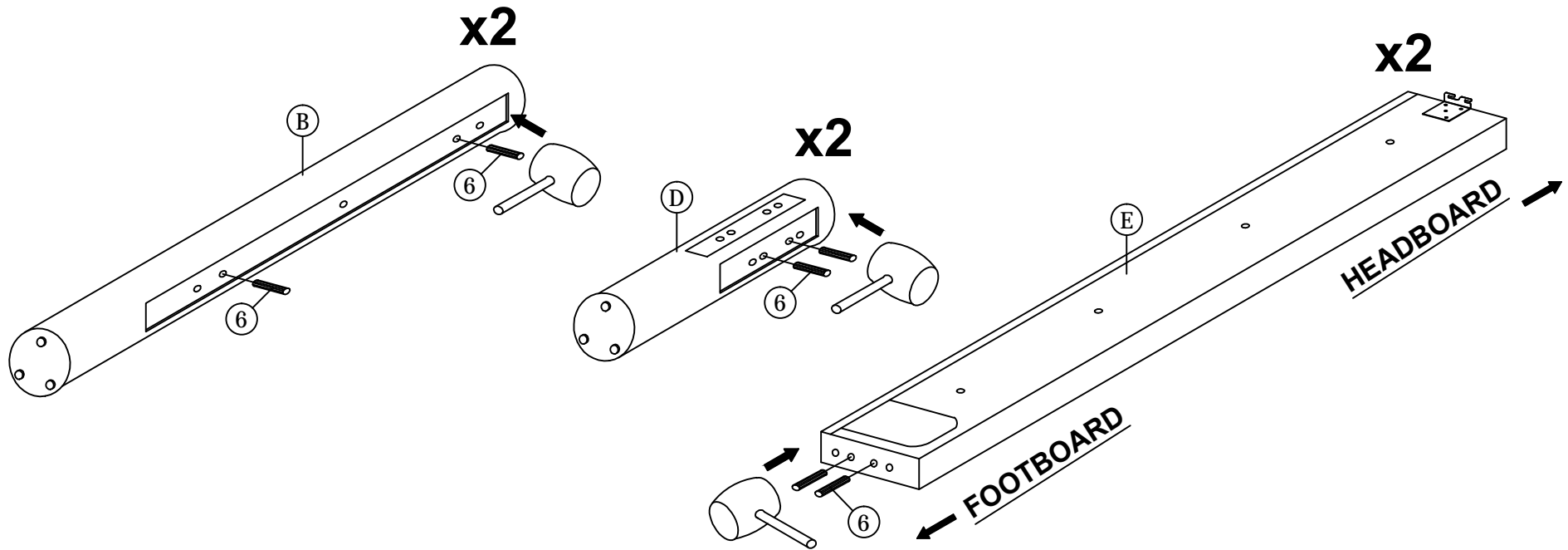

ASSEMBLY INSTRUCTIONS

STEP 2

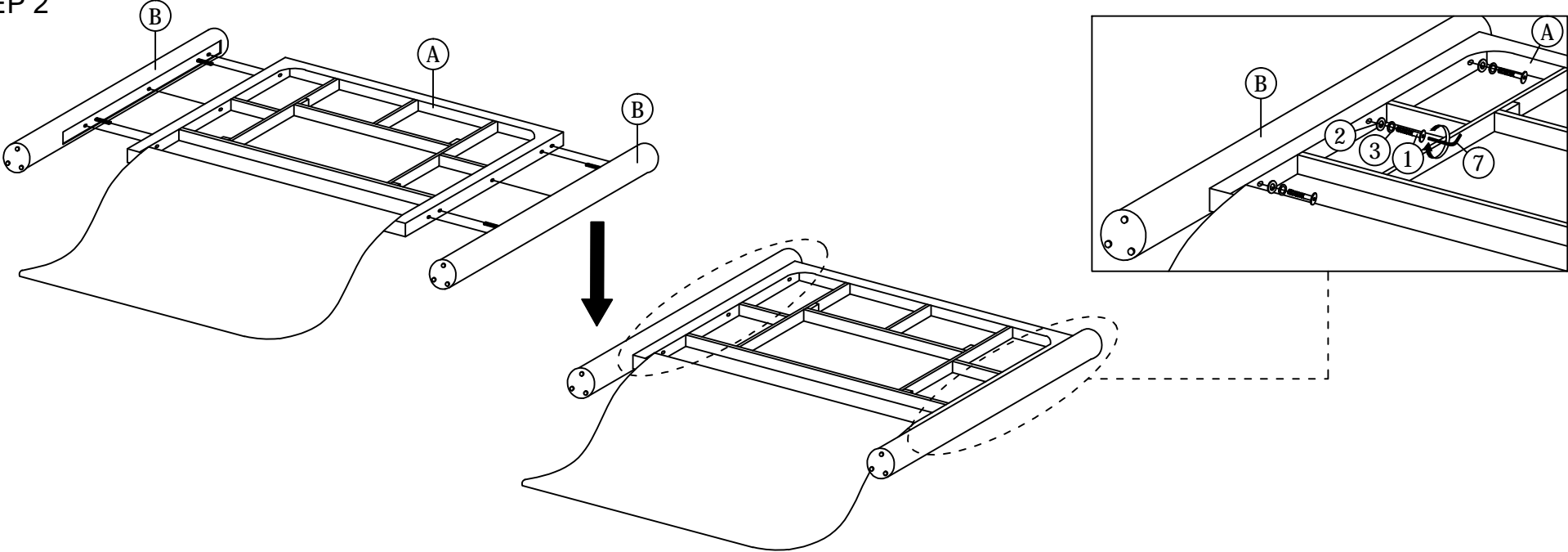

STEP 3

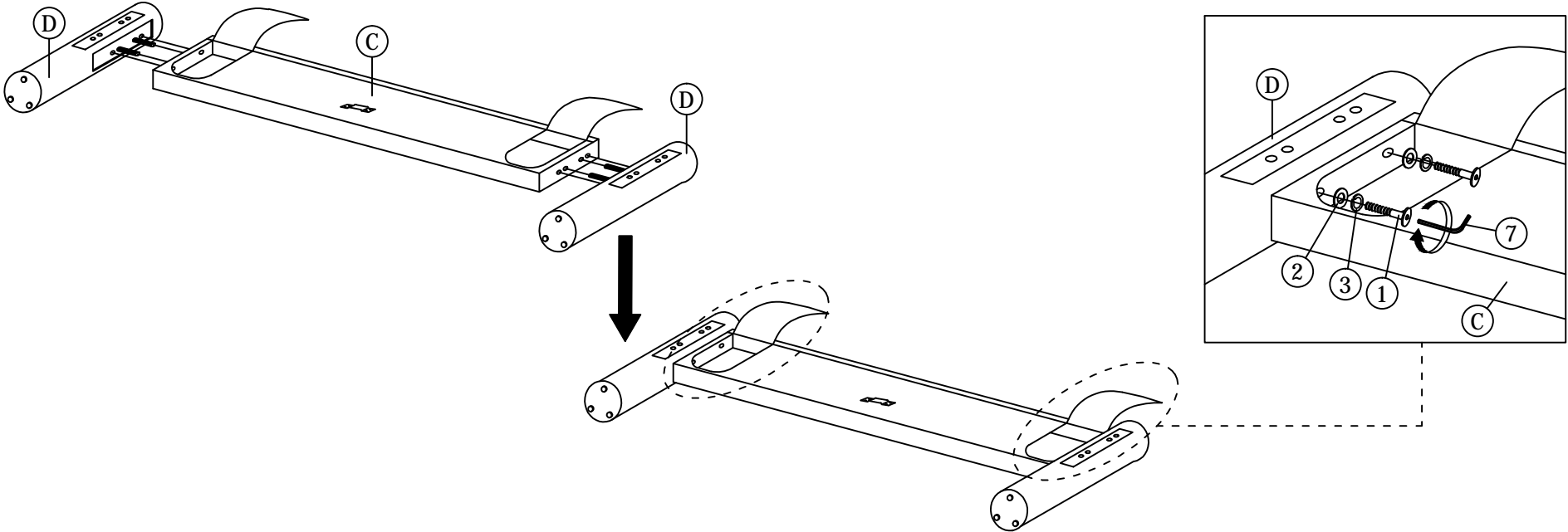

ASSEMBLY INSTRUCTIONS

STEP 4

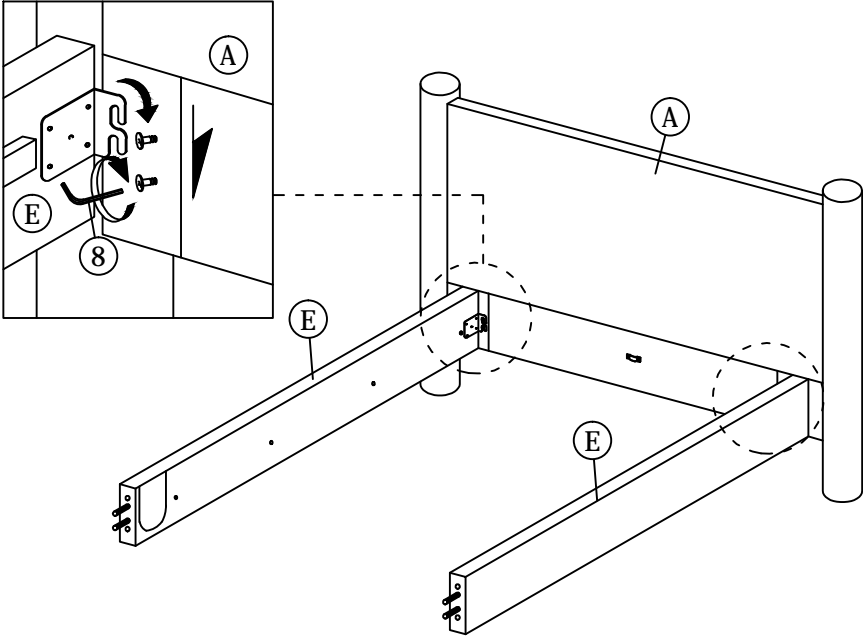

STEP 5

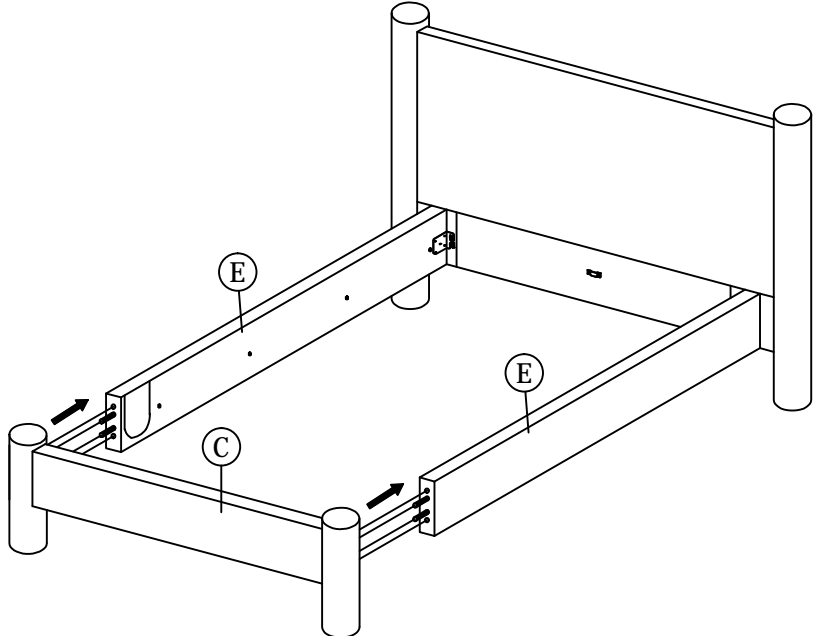

STEP 6

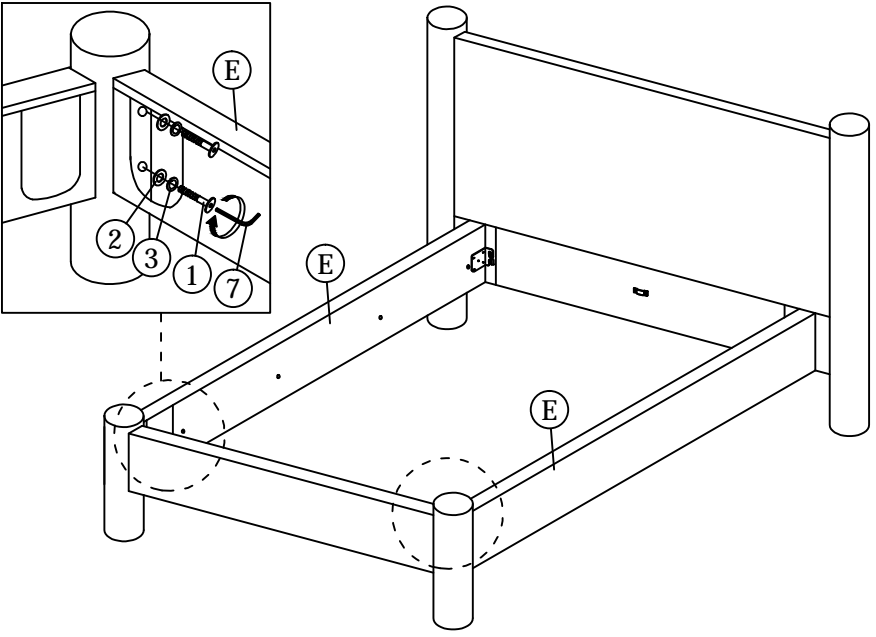

STEP 7

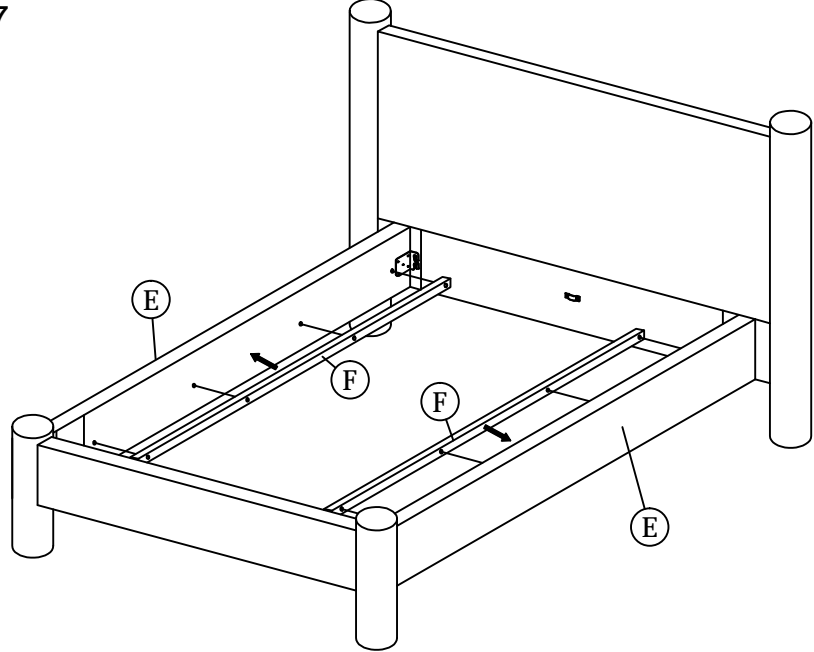

ASSEMBLY INSTRUCTIONS

STEP 8

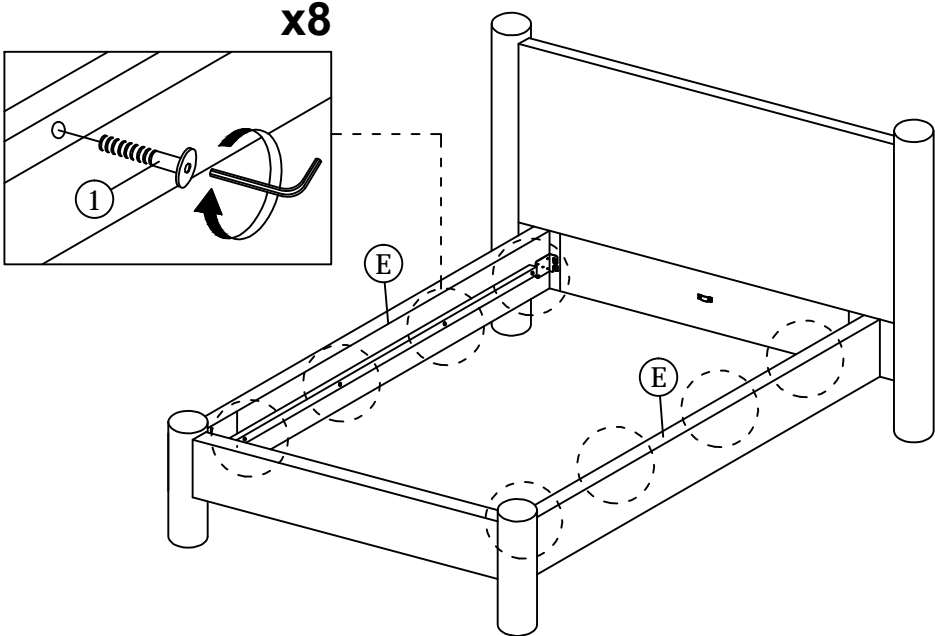

STEP 9

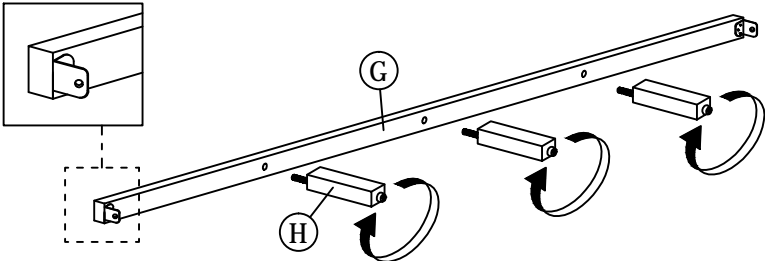

STEP 10

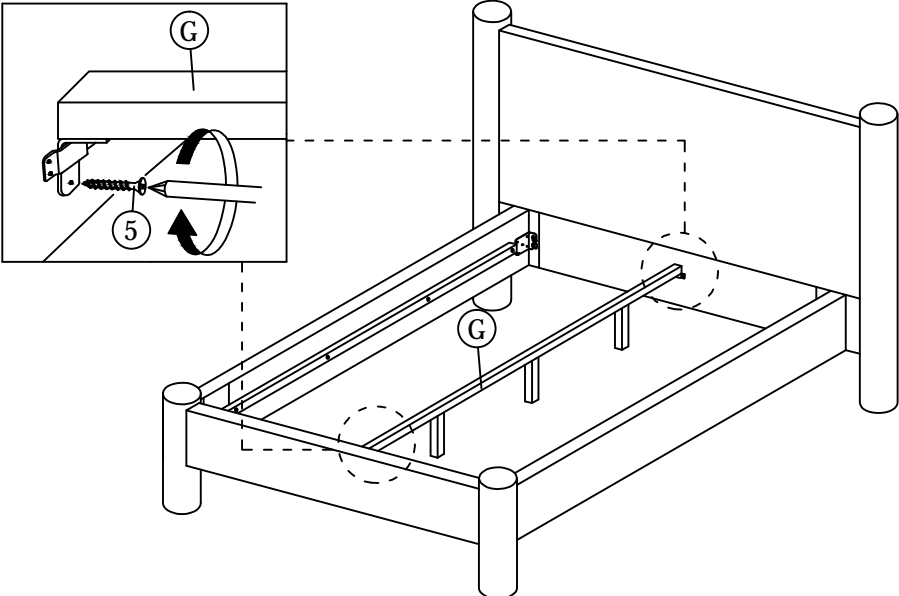

STEP 11

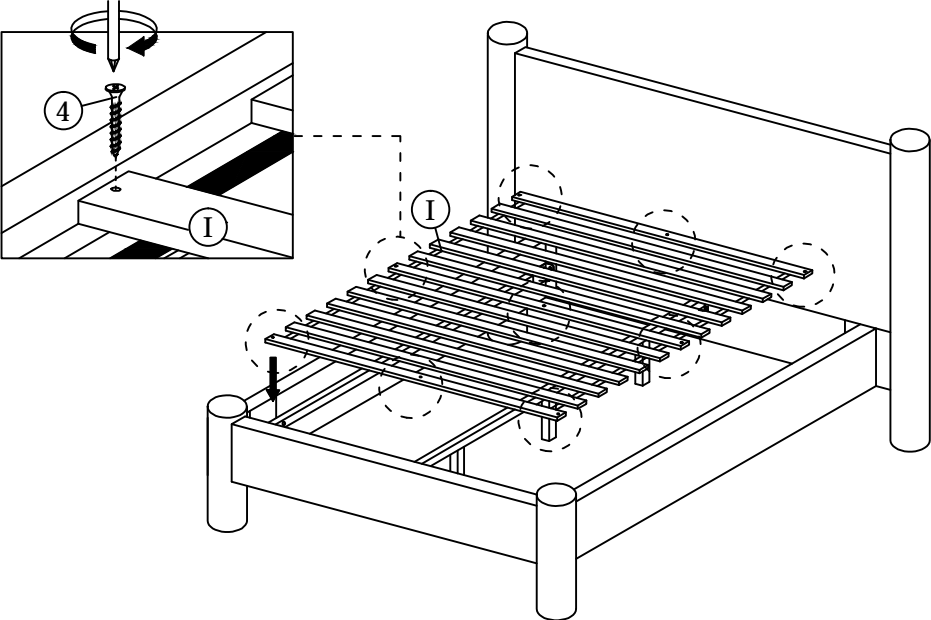

ASSEMBLY INSTRUCTIONS

5 OF 5

STEP 12

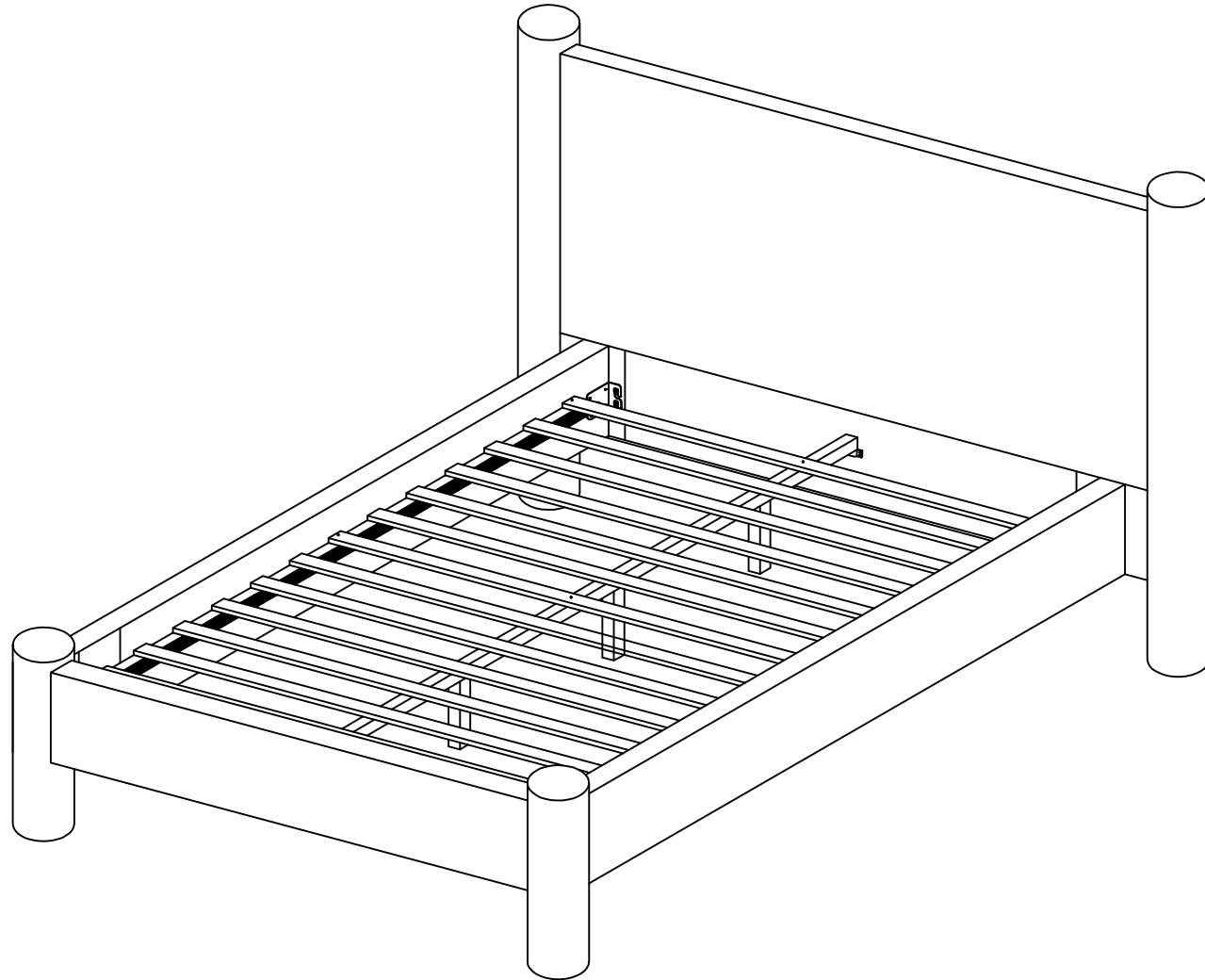

* When moving the bed position, the center support legs must be adjust to be straight to avoid any broken problem.

Read this instruction carefully. See hardware and furniture part list for guidance. Be sure all parts are complete, before you assemble. Place all wooden furniture parts on a clean and flat soft surface to prevent from being scratched. Follow the figure to start assembling.

CAUTIONS : 1. Do not FULLY - TIGHTEN the nut or nut bolt until all nut or bolt is ready assembled.
 2. Do not OVER - TIGHTEN the nut or bolt to avoid causing damages to the thread.
 3. Keep all hardware parts out of reach of children.

NOTE : THE LIST AND QUANTITY SHOWN ARE FOR 1 UNIT ASSEMBLY.
 Tool needed : Screwdriver (not provider).

PART LIST			
ITEM	DESCRIPTION	BOX	QTY
A	BODY	1	1 PC
B	HANDLE	1	2 PCS
C	HANDLE SCREW	1	4 PCS
D	FLAT WASHER	1	4 PCS
E	DRAWER	1	2 PCS

HARDWARE LIST (BOX : -)		
ITEM	DESCRIPTION	QTY
-	-	-

STEP 1

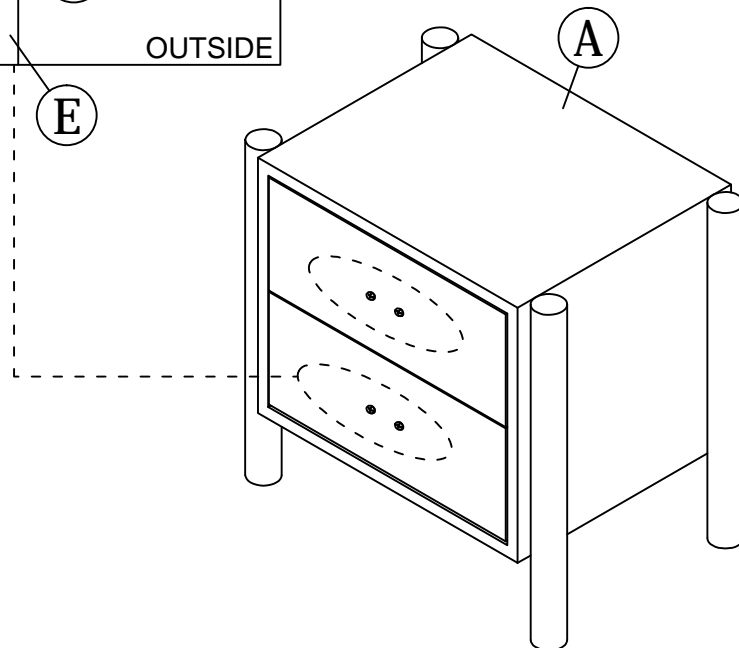
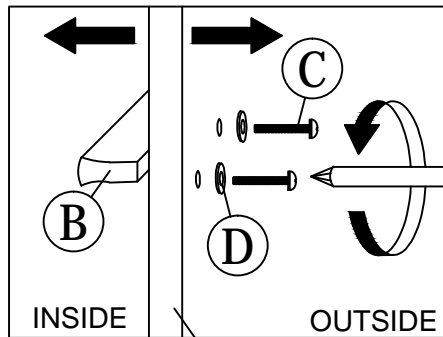

STEP 2

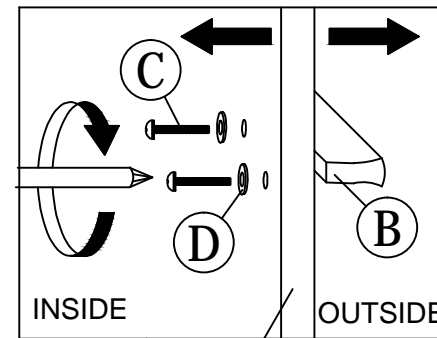

Note :
 Hold the handle flat and then tighten the screws

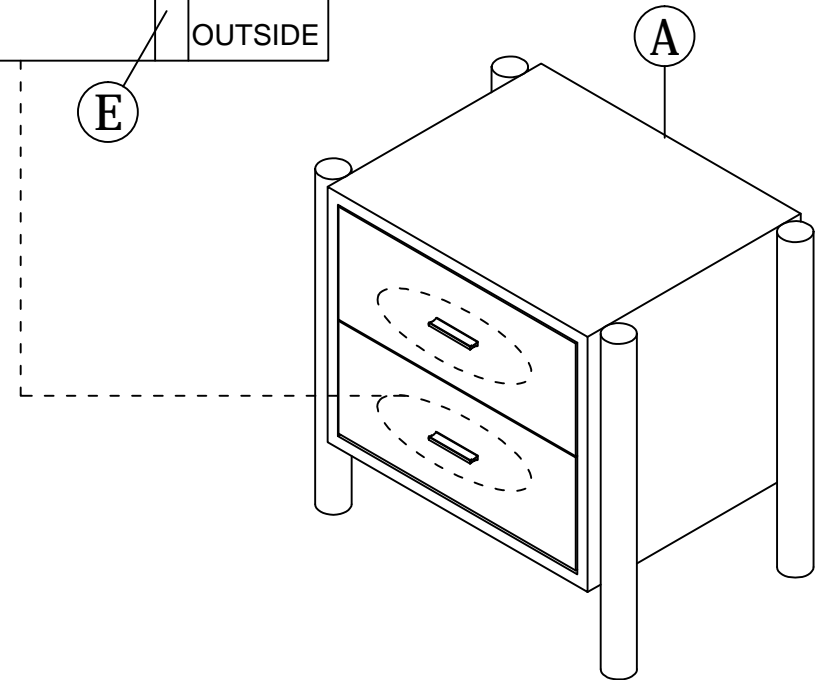

STEP 3

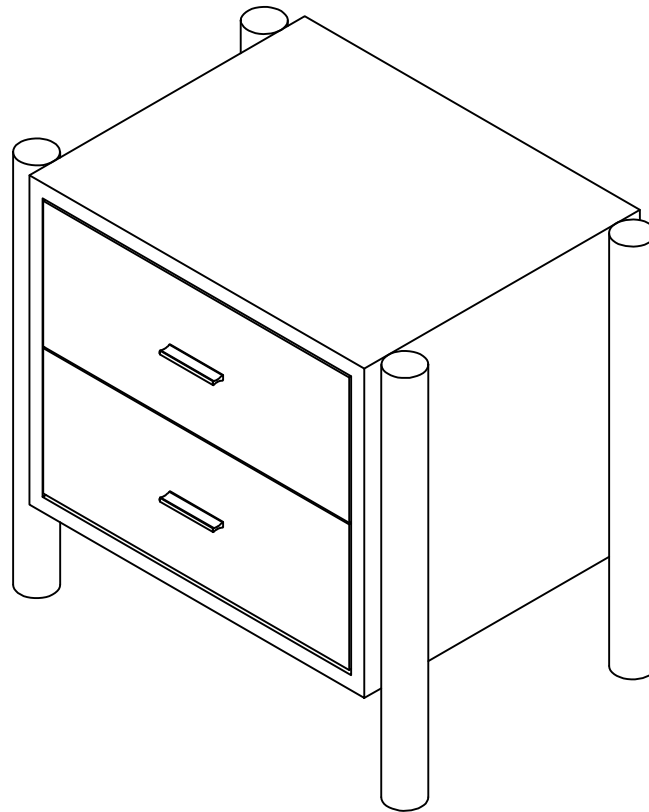

Read this instruction carefully. See hardware and furniture part list for guidance. Be sure all parts are complete, before you assemble. Place all wooden furniture parts on a clean and flat soft surface to prevent from being scratched. Follow the figure to start assembling.

CAUTIONS : 1. Do not FULLY - TIGHTEN the nut or nut bolt until all nut or bolt is ready assembled.
2. Do not OVER - TIGHTEN the nut or bolt to avoid causing damages to the thread.
3. Keep all hardware parts out of reach of children.

NOTE : THE LIST AND QUANTITY SHOWN ARE FOR 1 UNIT ASSEMBLY.
Tool needed : Screwdriver (not provider).

PART LIST			
ITEM	DESCRIPTION	BOX	QTY
A	BODY	1	1 PC
B	HANDLE	1	6 PCS
C	HANDLE SCREW	1	12 PCS
D	FLAT WASHER	1	12 PCS
E	DRAWER	1	6 PCS

HARDWARE LIST		
ITEM	DESCRIPTION	QTY
-	-	-

STEP 1

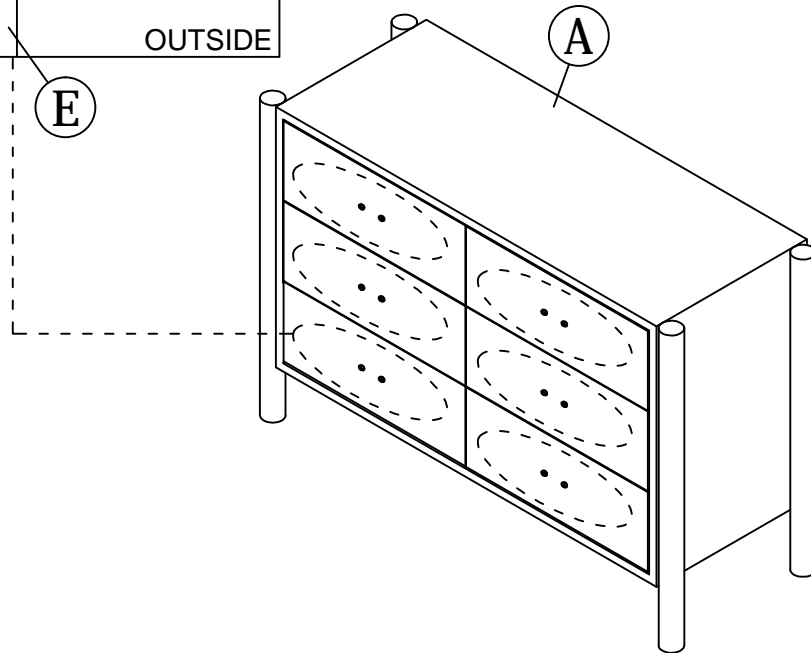
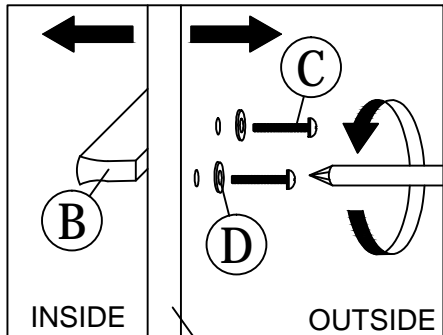

STEP 2

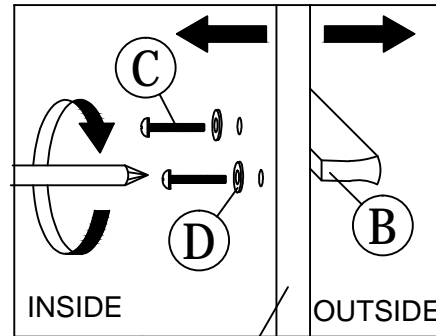

Note :
Hold the handle flat and then tighten the screws

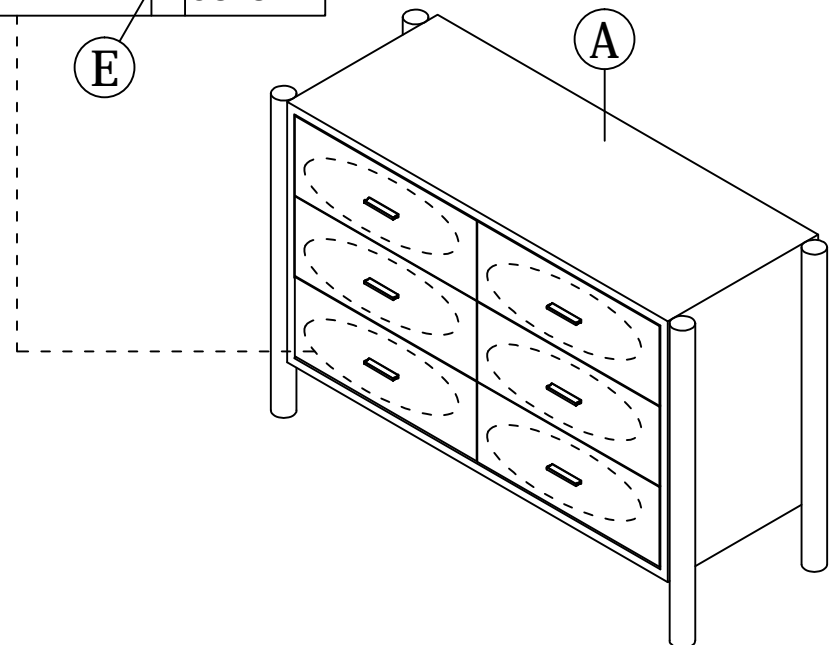

ASSEMBLY INSTRUCTIONS

STEP 3

