

# Assembly Instructions

**Caution: You must read this before you proceed**

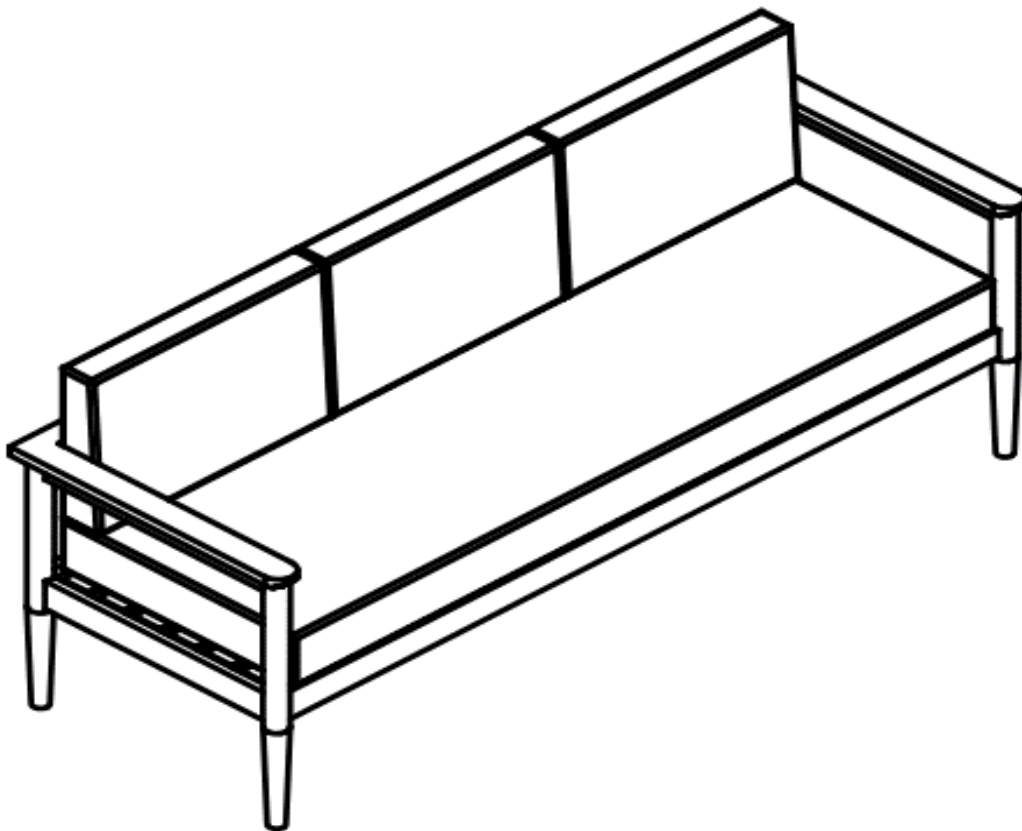



**Please look in the Leg for hardware packs**

## **3 SEATER**



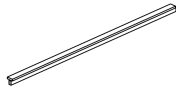

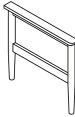
**CAUTION:** This 3 Seater is NOT a TOY.  
Keep your child / children at bay during the assembly process.  
Whenever lifting or moving the 3 Seater and to prevent damage to the 3 Seater, two adults may be needed to execute these actions.

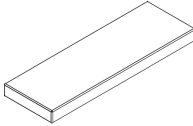
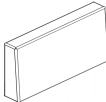
## Parts List

Label	Picture	Description	QTY
A		Backrest Panel	1
B		Seat Panel	1
C		Right Arm with Leg	1
D		Left Arm with Leg	1
E		Suport	1
F		Support Leg	1
G		Seat Cushion	1
H		Back Cushion	3

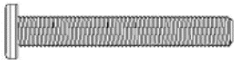
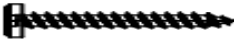
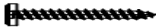
## Hardware

Label	Picture	Description	QTY
①		Bolt (M6 X 45mm)	5
②		Screw (M6 X 55mm)	3
③		Screw (M6 X 35mm)	5
④		Allen Key	2

## Assembly Preparation

Before Beginning Assembly:

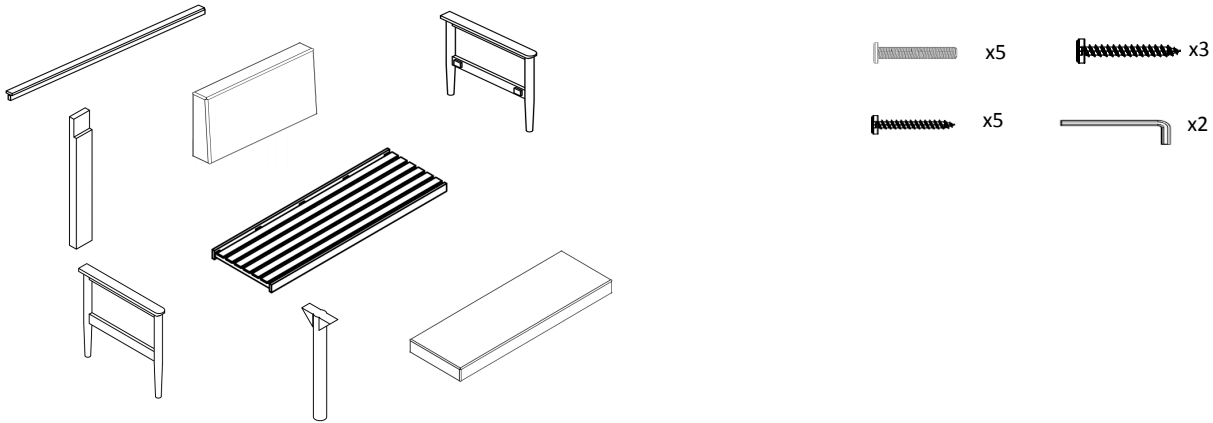

- Read instructions, cover to cover-



- Have 2 adults on hand for assembly-



- Do not assemble on flooring or carpet-



- Assemble on a clean non-marring surface (packing foam)-



- Save all packaging until finished-

## Assembly Steps

### Overview

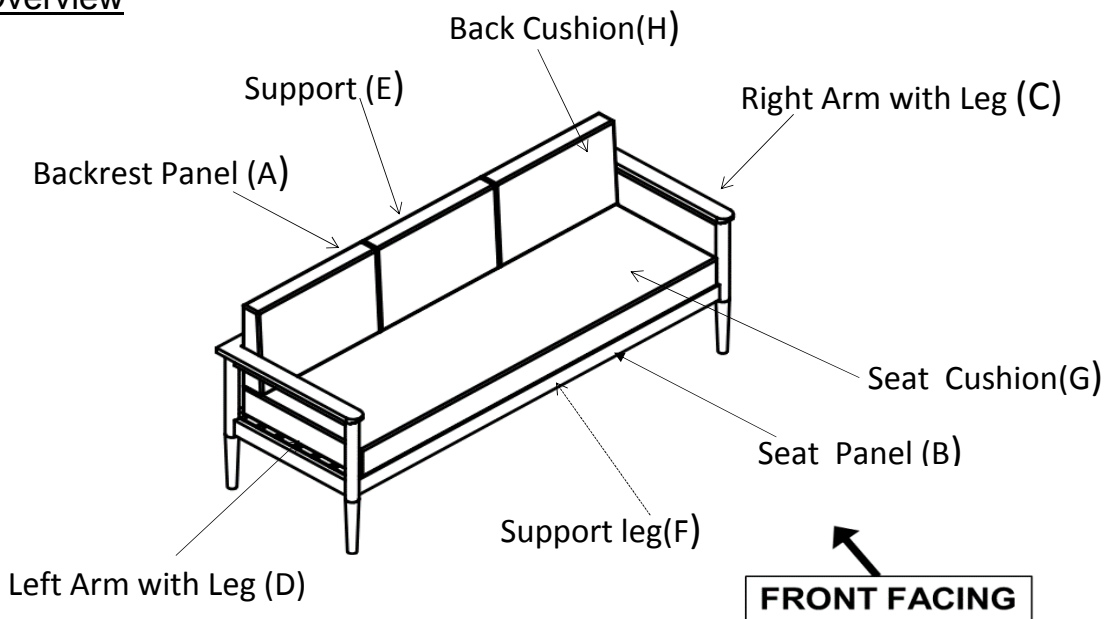

This Seater has multiple parts and may require up to 30 minutes to assemble. To give you an overview of the Seater, the above picture is to help you put the various parts into perspective. Please read through the instructions below to familiarise yourself with the parts and steps before assembly.

### Step 1

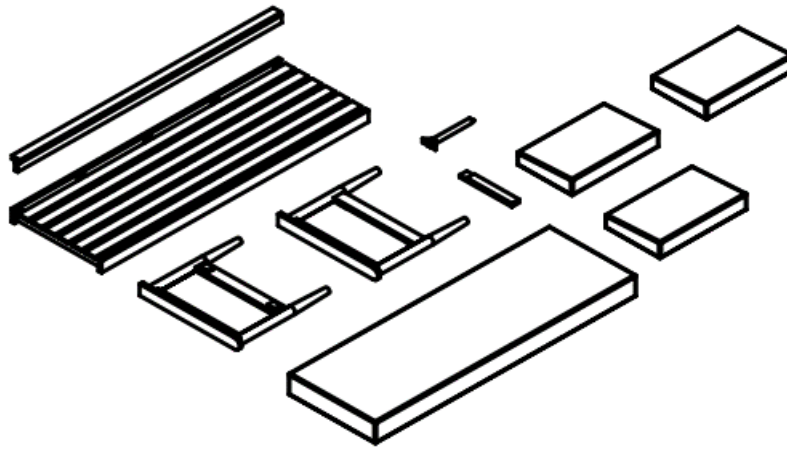

Unpack and place all parts on a clean, non-marring surface.

### Step 2

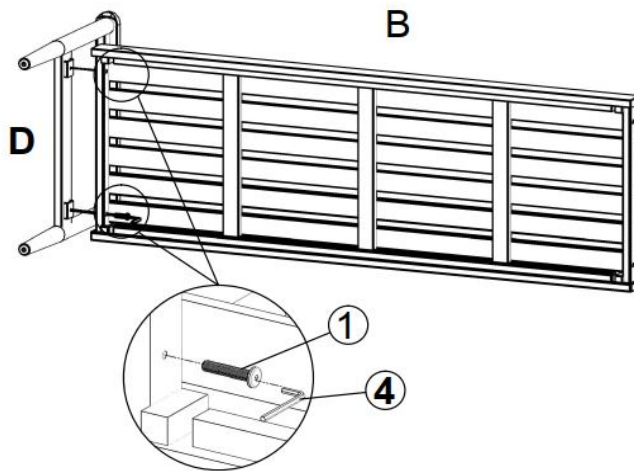

With the help of your adult partner, attach the Left Arm with Leg (D ) to Seat Panel (B) by using Bolt (1) and Allen Key (4) as shown above

Repeat the same process with Right Arm with Leg (C)

**Do not fully tighten the Bolts**

### Step 3

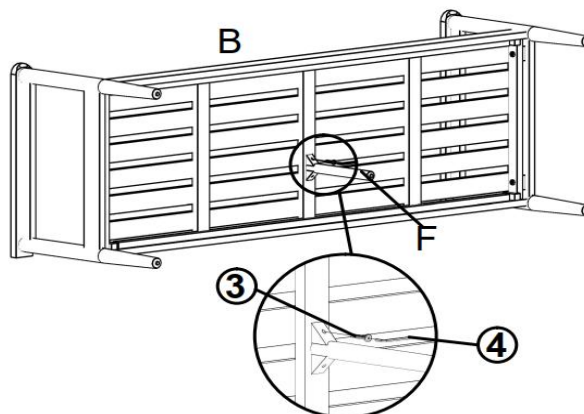

Attach Support Leg (F) into the Seat Panel (B) of the assembled part in Step 2, using Screw (3) and Allen Key (4)

**Do not fully tighten the Screws**

### Step 4

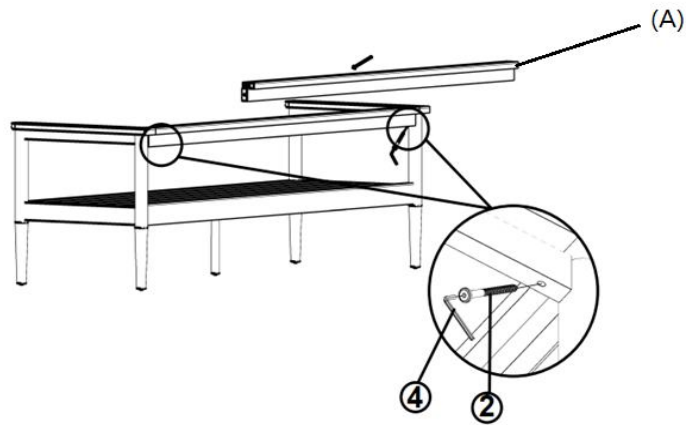

With the help of your adult partner, turn the assembled part in step 3 right side up. Attach Backrest Panel (A) into the Right Arm with Leg (C), Left Arm with Leg (D) using Screw (2) and Allen Key (4)

**Do not fully tighten the Screws**

### Step 5

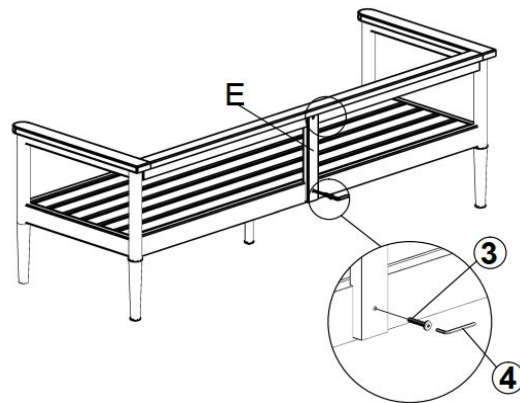

Attach Support (E) into the Seat Panel (B) and Backrest Panel (A) as shown above, using Screw (3) and Allen Key (4)

**Do not fully tighten the Screws**

### Step 6

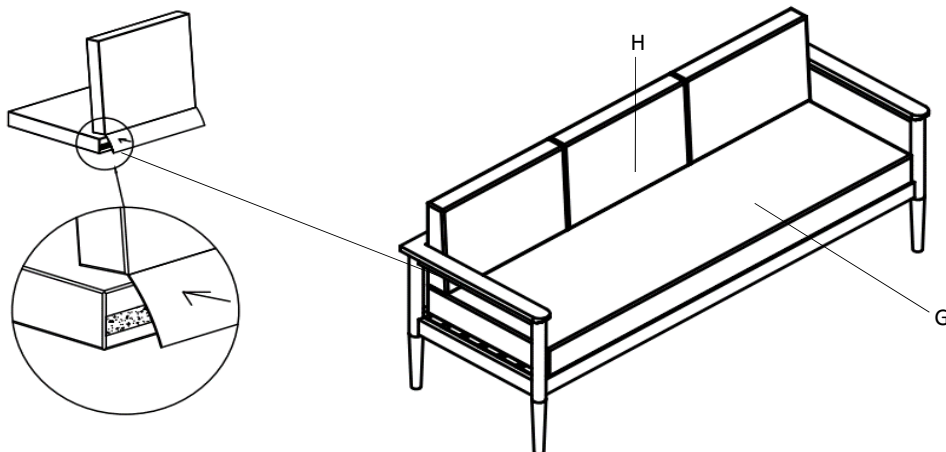

Place Seat Cushion (G), Back Cushion (H) onto the Seater then position Back Cushion (H) with the Seat Cushion (G) as show above

## Step 7:

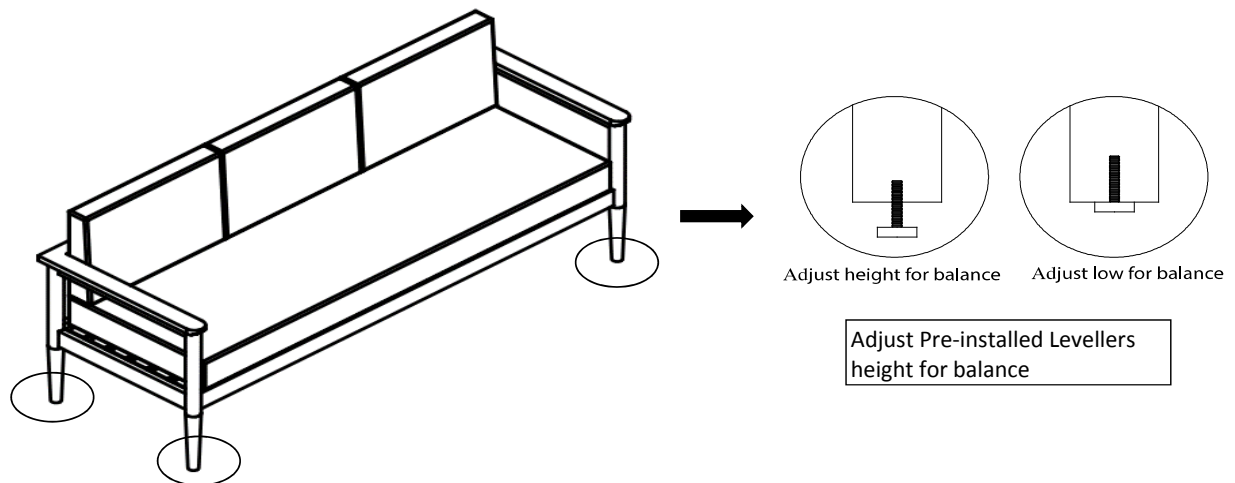

Place the Seater on a LEVEL SURFACE.  
Inspect it and make sure all parts are adequately connected.  
Gently and gracefully, sit into to the Seater.  
This will help align all the parts at all joint areas.  
Then get off the Seater and proceed to tighten the Bolts in a sequential manner.  
When tightening the Bolts tighten sequentially.  
DO NOT tighten any Bolt and Screw fully and then move on towards the next one.  
If there are any wobbles after tightening, loosen the Bolts/Screws and execute this same process.

Adjust the Levellers until the Seater is level with the ground.  
To adjust the Levellers, get assistance from an adult partner to lift/lean and hold the Seater while you are working.

**Your Seater is ready to be used.**

**This Seater can only be used on a flat, level surface.**

## Care & Maintenance

- ⊗ ☕ ● Do not put hot items directly on furniture surface.
- ⊗ 🧼 ● Do not clean furniture with harsh cleansers or polish.
- ✓ ☀ ● To obtain the longest lifespan of your outdoor products, minimizing exposure to direct sunlight is recommended.
- ⊗ 🧒 ● Children should not climb or jump on the furniture.
- ⊗ ✍ ● Do not write on furniture without a padded barrier to protect the surface.
- ✓ ☁ ● To obtain the longest lifespan of your outdoor products, avoid extended and lengthy exposure to rain, snow, and direct sunshine. Whenever possible cover the product and /or place under patio or awnings.
- ⊗ 🏢 ● Not for commercial use. For residential use only.
- ⊗ 🧴 ● Stains may be removed with mild soap solution and damp cloth.
- ✓ 🧻 ● Dust and pick-up spills using a clean, non-colored, lint-free cloth .