

VEVOR[®]

TOUGH TOOLS, HALF PRICE

Technical Support and E-Warranty Certificate www.vevor.com/support

HEAT PRESS MACHINE

We continue to be committed to provide you tools with competitive price.

"Save Half", "Half Price" or any other similar expressions used by us only represents an estimate of savings you might benefit from buying certain tools with us compared to the major top brands and does not necessarily mean to cover all categories of tools offered by us. You are kindly reminded to verify carefully when you are placing an order with us if you are actually saving half in comparison with the top major brands.

VEVOR[®]

TOUGH TOOLS, HALF PRICE

HEAT PRESS MACHINE

MODEL: SJY-H15151P/SJY-H12151P





NEED HELP? CONTACT US!

Have product questions? Need technical support? Please feel free to contact us:

Technical Support and E-Warranty Certificate
www.vevor.com/support

This is the original instruction, please read all manual instructions carefully before operating. VEVOR reserves a clear interpretation of our user manual. The appearance of the product shall be subject to the product you received. Please forgive us that we won't inform you again if there are any technology or software updates on our product.

Symbol	Symbol Description
	<p>Warning: To reduce the risk of injury, the user must read the instructions manual carefully.</p>
	<p>This symbol, placed before a safety comment, indicates a kind of precaution, warning, or danger. Ignoring this warning may lead to an accident. To reduce the risk of injury, fire, or electrocution, please always follow the recommendations shown below.</p>
	<p>CORRECT DISPOSAL: This product is subject to the provision of European Directive 2012/ 19/EC. The symbol showing a wheeled bin crossed through indicates that the product requires separate refuse collection in the European Union. This applies to the product and all accessories marked with this symbol. Products marked as such may not be discarded with normal domestic waste, but must be taken to a collection point for recycling electrical and electronic devices.</p>

WARNING

1. Warnings must be followed carefully to avoid body injury, improper use may result in electric shock, fire, personal injury and other damage.

- 1) Keep unplug when moving the machine.
- 2) Keep unplug when installing accessories.
- 3) Place on a flat and stable platform and operate under ventilated conditions.
- 4) Wear special protective equipment when operating the machine.
- 5) Do not use this machine in a hazardous-location.
- 6) Do not use when the machine is not working properly.
- 7) Do not disassemble and repair this machine.
- 8) Do not use an unsuitable AC Outlet.
- 9) Do not touch the heating plate when the machine is heating .
- 10) Do not use in humid environment or contact with water. Do not infiltrate liquid in the machine to prevent fire or electric shock caused by short circuit.

11) Do not use the power supply that does not meet the rated voltage. The power supply that does not meet the specified voltage may cause fire or electric shock.

12) Ensure that the machine is grounded so as not to cause harm to body.

13) Do not touch the rotating rod or bearing part with your fingers during use in case of injuries.

14) If the machine is not in use for a long time, please unplug the power cord from the socket.

15) Do not use the machine during thunderstorms or lightning to avoid damage to the machine.

16) Place the machine smoothly on the flame-retardant table and keep away from flammable and explosive items.

17) Please stop using it if the machine smokes, emits a peculiar smell, or becomes noisy and in other abnormal conditions.

18) This appliance can be used by children aged from 8 years and above and persons with reduced physical, sensory or mental capabilities or lack of experience and knowledge if they have been given supervision or instruction concerning use of the appliance in a safe way and understand the hazards involved. Children shall not play with the appliance. Cleaning and user maintenance shall not be made by children without supervision

19) Type X attachment: If the supply cord is damaged, it must be replaced by a special cord or assembly available from the manufacturer or its service agent.

20) In order to avoid a hazard due to inadvertent resetting of the thermal cutout, this appliance must not be supplied through an external switching device, such as a timer, or connected to a circuit that is regularly switched on and off by the utility.



Warning

Please turn off the power when plug or unplug the connector



FCC INFORMATION

CAUTION: Changes or modifications not expressly approved by the party responsible for compliance could void the user's authority to operate the equipment!

This device complies with Part 15 of the FCC Rules. Operation is subject to the following two conditions:

- 1) This product may cause harmful interference.
- 2) This product must accept any interference received, including interference that may cause undesired operation.

WARNING: Changes or modifications to this product not expressly approved by the party responsible for compliance could void the user's authority to operate the product.

Note: This product has been tested and found to comply with the limits for a Class B digital device pursuant to Part 15 of the FCC Rules. These limits are designed to provide reasonable protection against harmful interference in a residential installation.

This product generates, uses and can radiate radio frequency energy, and if not installed and used in accordance with the instructions, may cause harmful interference to radio communications. However, there is no guarantee that interference will not occur in a particular installation. If this product does cause harmful interference to radio or television reception, which can be determined by turning the product off and on, the user is encouraged to try to correct the interference by one or more of the following measures.

- Reorient or relocate the receiving antenna.
- Increase the distance between the product and receiver.
- Connect the product to an outlet on a circuit different from that to which the receiver is connected.
- Consult the dealer or an experienced radio/TV technician for assistance.

Contents

1. SPECIFICATION.....	6
2. MACHINE STRUCTURE PRESENTATION.....	7
3. PART LIST.....	8
4. CUP BAKING MACHINE PACKING LIST.....	9
5. INSTALLATION STEPS FOR CUP BAKING MACHINE.....	10
6. OPERATION.....	12
7. CONTROL PANEL.....	13
8. PARAMETER SETTING.....	14
9. REPLACE BAKING TRAY MAT.....	16
10. REPLACE BAKING CAP MAT.....	17
11. REPLACE BAKING COASTER.....	19
12. RECOMMENDED PARAMETER.....	21
13. TROUBLE SHOOTING.....	22

1. SPECIFICATION

Model	SJY-H15151P		SJY-H12151P	
Heat Size	15x15inch		12x15inch	
Temperature Range	32-480°F(0-250℃)		32-480°F(0-250℃)	
Product				
Product Size	18.1x15.3x13.4in (46x39x34cm)		16.5x15.3x13.4in (42x39x34cm)	
Time Range	0-999 Seconds		0-999 Seconds	
Voltage	120V~ 60Hz	220-240V~ 50Hz	120V~ 60Hz	220-240V~ 50Hz
Power	1400W	1350W	950W	900W

2. MACHINE STRUCTURE PRESENTATION

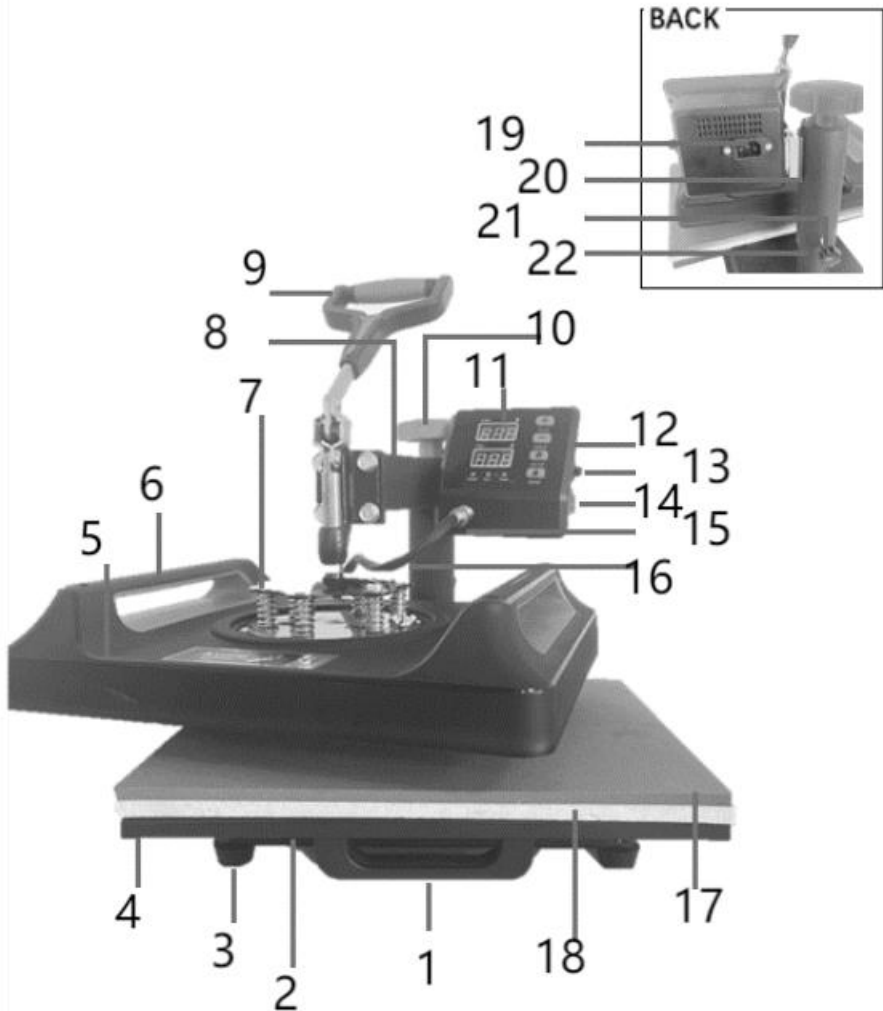

Number	Part name	Number	Part name
1	Slide Handle	2	Bottom Board
3	Footpad	4	Flat Platen

5	Flat Platen	6	Swing Handle
7	Pressure Plate	8	Support Arm
9	Lift handle	10	Pressure Adjustment Knob
11	Control Panel	12	Control box
13	Reset coin	14	Power Switch
15	Signal Port	16	Signal Cable
17	Silicone Mat	18	Foam mat
19	Power Inlet	20	Upper Column
21	Locking Knob	22	Lower Column

3. PARTS LIST

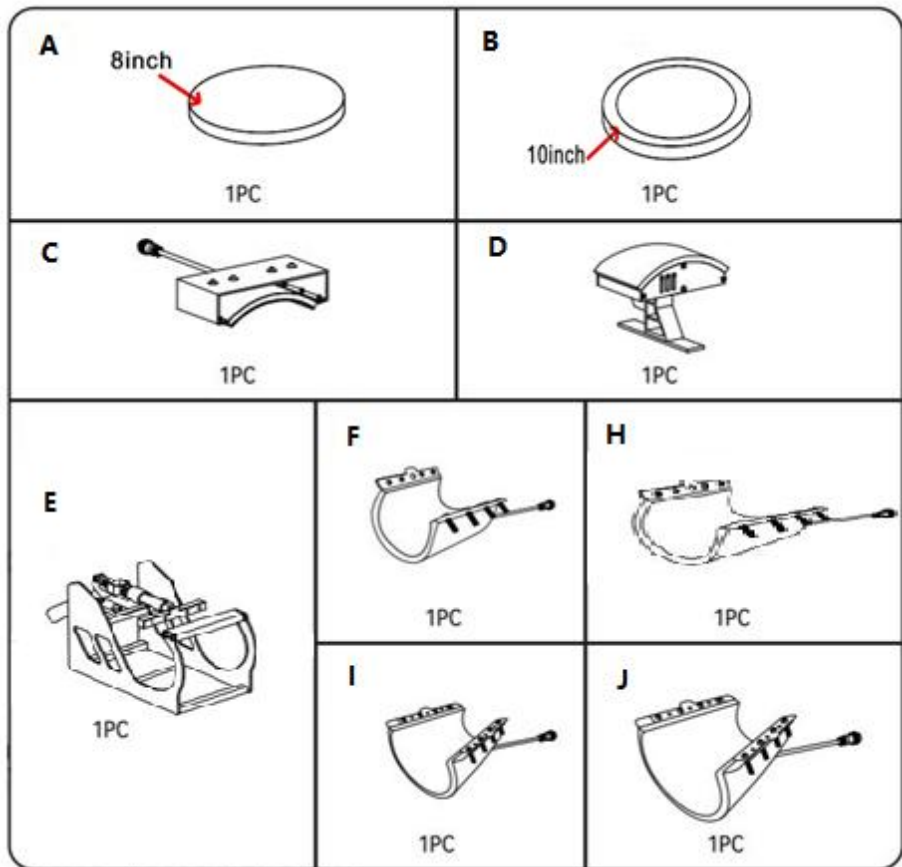









A: 8inch Plate Press Attachment	B: 10in Plate Press Attachment	C: Arched Press Plate
D: Curved Base	E: Mug Press Frame	F: 6oz Mug Press Attachment

H: 30oz Mug Press Attachment	I: 12oz Mug Press Attachment	J: 17oz Mug Press Attachment
K: Power cord		

	Part A	Part B	Part C	Part D	Part E	Part F	Part H	Part I	Part J
5in1	√	√	√	√	√		√		
8in1	√	√	√	√	√	√	√	√	√

4. CUP BAKING MACHINE PACKING LIST

No.	Picture	Component	Quantity
①		5*6mm round head screws	18
②		Round tube	3
③		side panel	2
④		four-hole billiards	1
⑤		straight handle	1
⑥		Heating elements for cups	1

⑦		8*12mm Yuan machine screws	4
⑧		Adjustment knob	1
⑨		plane strip	1

5. INSTALLATION STEPS FOR THE MUG HEAT PRESS

1. Installation steps

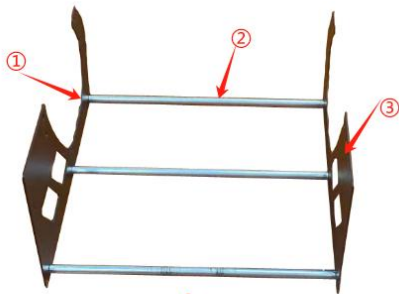

A
Combine ①②③



B Combine A④⑨



C
Combine ⑤⑧



D
Secure B and C with ⑦

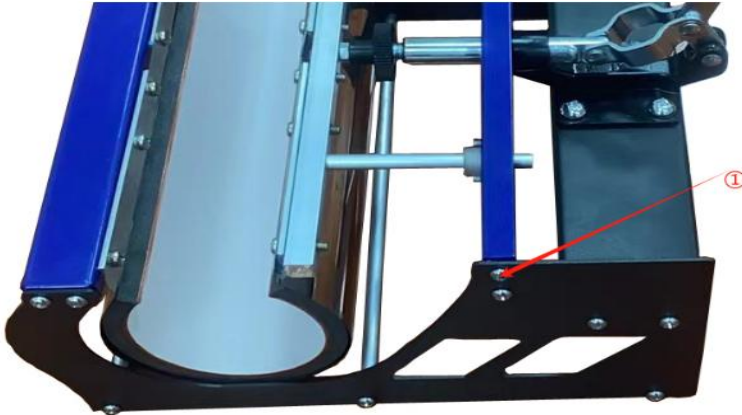

E Fix the left and right sides with ①

Installation
complete

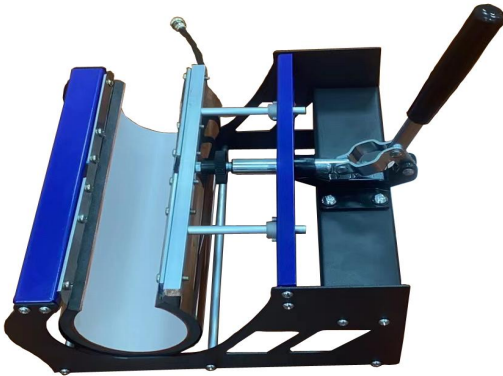
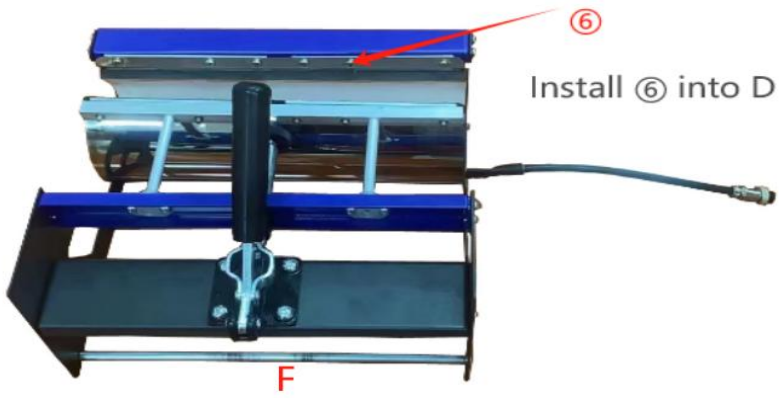

6. OPERATION

1

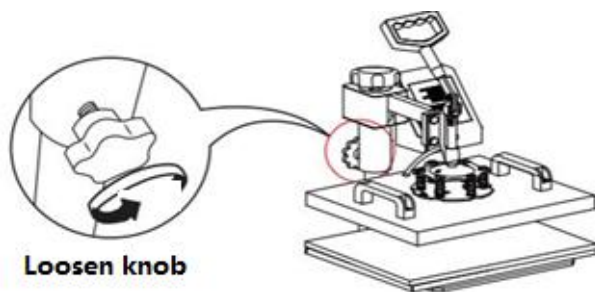

2

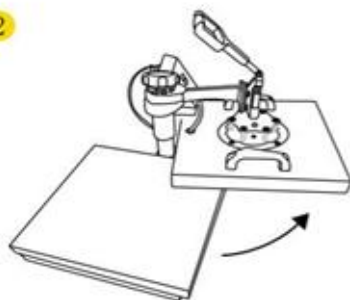

Rotate the heat transfer board to the side

3

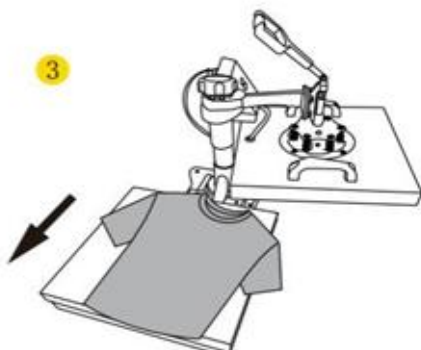

Pull out the mat below, place the clothes flat on the mat and place the pattern on the clothes

4



Turn this knob to adjust the pressure
Clockwise to add pressure
Anticlockwise to reduce pressure

5

Tighten knob

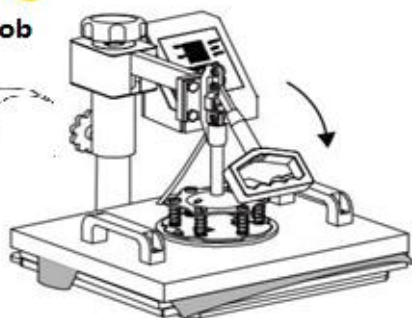

7. CONTROL PANEL

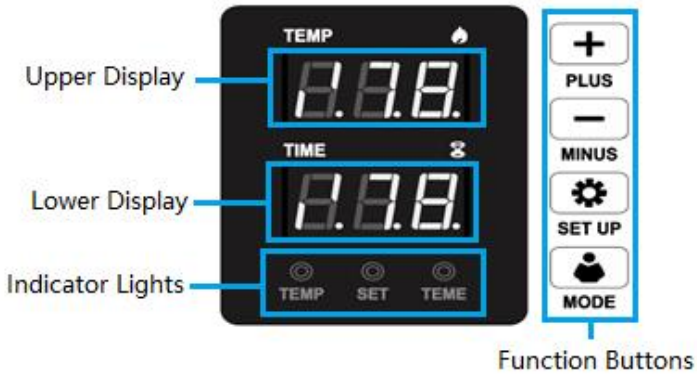

Display Areas	Upper	Displays temperature values or parameter names.
	Lower	Displays timer values or parameter settings.
Indicator Lights	Temp	Indicates heating is operating.
	Set	Indicates setting is operating.
	Time	Indicates countdown time is operating.
Function Buttons	+ PLUS	Increases values or converts settings in parameter menus.
	- MINUS	Decreases values or converts settings in parameter menus
	SET UP	Enters/Exits primary parameter menus or confirms settings when pressed.
	MODE	Change temperature unit (°C or °F) Starts/Stops/Resets countdown

8. PARAMETER SETTING



1.HOW TO TURN ON/OFF AND HOW TO START?



Press the switch button on the side of the digital box to start the machine.

After setting temperature, press "MODE" button once to count down, and press again to reset.

2.HOW TO SET THE TEMPERATURE/TIME?



Press once to set the temperature, press twice to set the time, press three times to change temperature unit and press again to exit.

3.HOW TO SET THE TEMPERATURE/TIME TO INCREASE OR DECREASE?

+ Set the time/temperature increase

— Set the time/temperature decrease

4.HOW TO CHANGE THE TEMPERATURE UNIT FROM F AND C?

Press "SET UP" button 3 times, the display will showing C-F, please press "+" or "-" to adjust C(Celsius) or F(Fahrenheit) according to your demands.

5.HOW TO DO TEMPERATURE CORRECTION?

Press and hold for 5 seconds to enter the temperature correction setting.

(Range+30°C or-30°C, initial value is 0)

HOW TO HEAT PRESSING?(FOR EXAMPLE,T-SHIRT PRINTING)

- 1.Make sure the wire is well connected, and the power plug is well connected to the wall socket, then press the power switch to turn on.
 - 2.Rotate the pressure knob to get the right pressure required.
 - 3.Set the temperature and the time you want.
 - 4.The buzzer will sound when the temperature reaches the setting temperature. Then place the object (e.g. a T-shirt) on press bed, and let the transfer paper with images facing down the object (e.g. a T-shirt)(PS: It is suggested to put a white cloth upon the transfer paper to avoid unnecessary mark when the temperature is too high.)
 - 5.Press down the handle (meantime the sound will stop), then press the "MODE" button to count down and machine will start to transfer.
 - 6.The buzzer will sound again when the scheduled time is up, then lift up the handle (meantime the sound will stop), the transfer work is finished.
- PS: If the flat base sliding become lagging, you can add some lubricating oil on the slide guide

HOW TO CALIBRATE YOUR HEAT PRESS MACHINE

1. Turn the pressure knob counterclockwise a few times to lower pressure on the platens.
- 2.Place a piece of paper onto bottom of the platen.
- 3.Close the revolve press using the handle.
- 4.Pull on the paper.
- 5.If the paper moves at all, turn the knob clockwise and try again.
- 6.Try again and repeat until the paper doesn't move at all. This is your "Medium" pressure. From the "Medium" setting, high pressure will be clockwise one to two turns. Low pressure will be counterclockwise one to two turns. (The number of turns will depend on the thickness of the garment.

SLIDE HANDLE ASSEMBLY METHOD



Use Phillips screwdriver assembly the slide handle (M5*20 screw and nuts)

9. REPLACE BAKING TRAY MAT

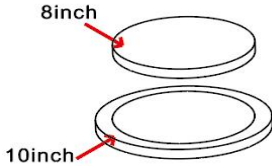

1. Use high-temperature tape to fix the pattern on the tray, and then cover it with a silicone mat of suitable size (8in or 10in).

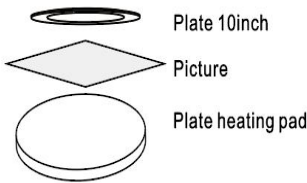

2. When reaching the set temperature, put the tray on the press bed. (Silicone mat opposite to bottom, tray bottom opposite to heating plate). It is suggested to set the countdown time around 15min (900s).

Ps. Refer to 'operation example'

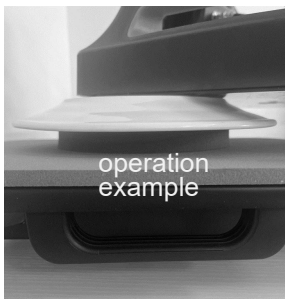

3. Remove the heating plate and place it on the plate, keeping the side without silica gel pad facing upward.



200°C 900S

Recommended parameter

Set Temp: 200°C

Count time: 900S

10. REPLACE BAKING CAP MAT

1



Screw the ball-head Phillips bolts back to the flat platen.

Note: Partially tighten them.

2



Firmly grasp the swing handles, lifting the platen up to the lower pressure plate and placing the bolts in the large slots as shown.

3

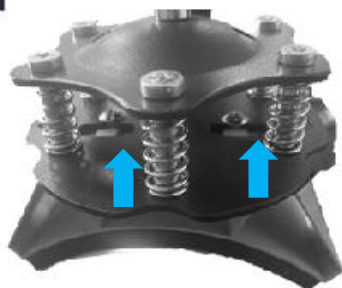

- Slide the bolts into the small slots.
- Tighten them **FULLY** to relock the platen.

4

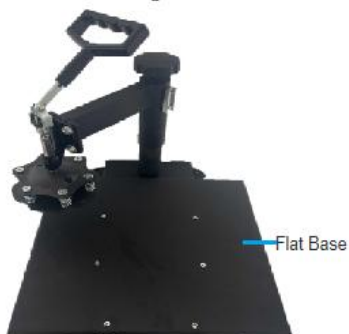

Turn the support arm to either side and remove the heat-resistant mats from the flat base.

5

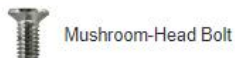

Unscrew the four mushroom-head bolts using a Phillips screwdriver (**not included**).

6

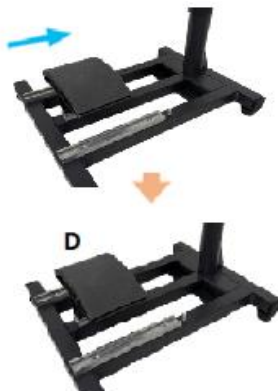

Slide the curved base (**D**) onto the rail as shown.

7



Push the press plate up to the lower pressure plate, placing the bolts in the large slots as shown.

- Slide the bolts into the small slots.
- Tighten them **FULLY** using a Phillips screwdriver (**not included**).

8



Turn back the support arm, placing the press plate above the curved base (**D**).

Note: If the press plate is not high enough to be positioned above the base, turn the pressure adjustment knob counterclockwise to raise the support arm and the plate.

11. REPLACE BAKING COASTER

1

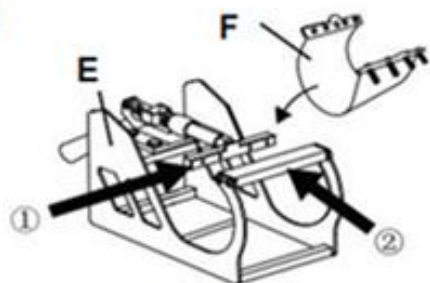

Install F to Part E
Direct put Part F in Part E,
ensure the screw tube through
in correct holes on both side.

Select the appropriate size
baking coaster (Part F or H) Put
the Cup in Part E

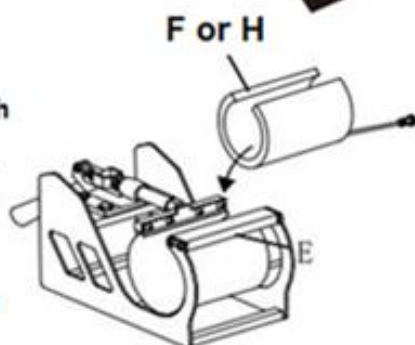
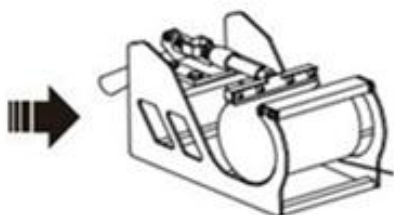

2

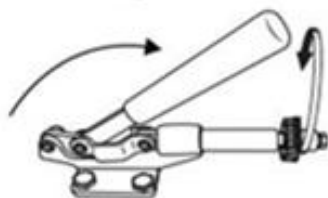

Adjust the tightness



Shaped Cup

1

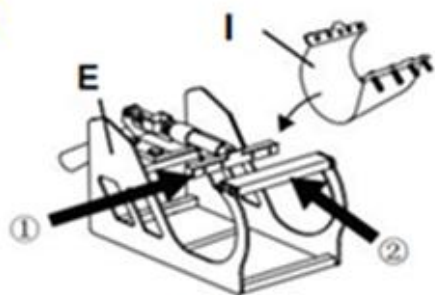

Instal I to Part E
Direct put Part I to Part E
ensure the screw tube through
in correct holes on both side.

Select the appropriate size
baking coaster (Part I or J) Put
the Cup in Part E



I or J

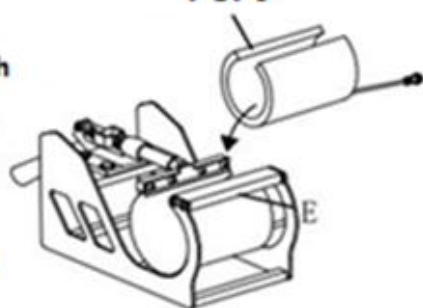

2

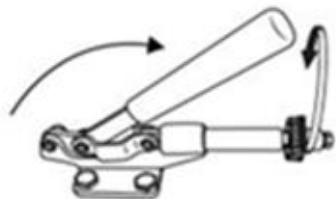

Adjust the tightness



Shaped Cup

12. RECOMMENDED PARAMETER

		
T-shirt (Non-cotton)	T-shirt (PU flex film)	Aluminum plate
392°F (200°C) 60s	338°F (170°C) 25s	338°F (170°C) 100s
		
Pillow	Mouse pad	Cloth bag
392°F (200°C) 60s	365°F (185°C) 50s	356°F (180°C) 60s

Material		Temperature		Time	Pressure
Aluminum Sheet		340–355°F	170–180°C	80–90 sec.	M
Aluminum Alloy Coating		355–390°F	180–200°C	45–60 sec.	M
Ceramics	Porcelain Cups	340–355°F	170–180°C	60–90 sec.	XL
	Color-Changing Cups	320–340°F	160–170°C	60–90 sec.	XL
	Plates or Dishes	320–355°F	160–180°C	60–90 sec.	XL
	Tiles	355°F	180°C	80–90 sec.	XL
Chemical Fibers or Fibres		320°F	160°C	20 sec.	M
Cotton (T-Shirts &c.)	PU Flex Film	340°F	170°C	25 sec.	H
	Sublimation	390°F	200°C	60 sec.	H
	Vinyl	320°F	160°C	15 sec.	M
Cotton Poly Blends		350°F	175°C	10 sec.	H
Crystal Photo Block		375°F	190°C	180 sec.	M
Glass Frames		320–340°F	160–170°C	60–90 sec.	XXL
Mousepads		355°F	180°C	60 sec.	M
Pillowcases & Linens		355°F	180°C	60 sec.	H
Polyester		270°F	130°C	10 sec.	H
Rhinstone Transfers		320°F	160°C	15 sec.	M
Slate Rock Photo		355°F	180°C	420 sec.	M
Wood		375°F	190°C	50 sec.	M
Stainless Steel Sports Bottle		320–340°F	160–170°C	60–90 sec.	M
Paperboard Pieces		355°F	180°C	60 sec.	M

Pressure Levels: XXL<XL<M<H

13. TROUBLE SHOOTING

1.The temperature is out of control: set temperature 180°C(356°F), but the actual temperature is above 200°C (392°F).

Wait for a while and check. If the emperature keeps an error beyond 20°F , contact us and we will change a new digital controller for you.

2.Temperature drops when the machine starts transferring.

It's normal if the machine drops within 10C, as the printed item is considerably cold. Part of the heat is transferred from machine to the printed item, especially when transferring patterns on mugs and plates.

3.Printed effect: print color is a pale or faded image.

The pressure is not high enough, the temperature is too low, or the pressing time is too short. Please adjust the pressure/temperature or increase the heating time.

4.Printed effect: print color is too darkened, deep or blurred

Reason 1: The temperature is too high /or the pressing time is too long. Please adjust the temperature or reduce the heating time.

Reason 2: Pressing time is too short/using poor quality transfer paper. Please increase the heating time or use high quality transfer paper.

5. Display screen does not turn on or display screen is working but temperature is not heating up.

6. Flat base pull or push action is lagging: Please add some lubricating oil on the slide guide.

Pls kindly send us your problems. Our staffs will give instructions according to your specific problems with patience. We will resend you the related spare parts to help solve the problems asap.

Ps. Pattern material always uses heat transfer paper and DTF film

Please check the DTF film suggested removing time to avoid that the remove time is incorrect cause failure.

Tutorial Video



Temperature controller operation method

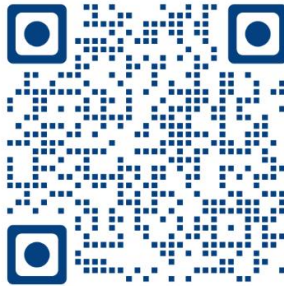

Temperature sensor replace tutorial

Manufacturer:Shanghaimuxinmuyeyouxiangongsi

Address: Shuangchenglu 803nong11hao1602A-1609shi, baoshanqu, shanghai 200000 CN.

Imported to AUS: SIHAO PTY LTD. 1 ROKEVA STREETEASTWOOD NSW 2122 Australia

Imported to USA: Sanven Technology Ltd. Suite 250, 9166 Anaheim Place, Rancho Cucamonga, CA 91730

EC	REP
-----------	------------

E-CrossStu GmbH

Mainzer Landstr.69, 60329 Frankfurt am Main.

UK	REP
-----------	------------

YH CONSULTING LIMITED.

C/O YH Consulting Limited Office 147, Centurion House,
London Road, Staines-upon-Thames, Surrey, TW18 4AX

VEVOR[®]
TOUGH TOOLS, HALF PRICE

Technical Support and E-Warranty Certificate
www.vevor.com/support