

Read this instruction carefully. See hardware and furniture part list for guidance. Be sure all parts are complete, before you assemble. Place all wooden furniture parts on a clean and flat soft surface to prevent from being scratched. Follow the figure to start assembling.

- CAUTIONS :**
1. Do not FULLY - TIGHTEN the nut or nut bolt until all nut or bolt is ready assembled.
 2. Do not OVER - TIGHTEN the nut or bolt to avoid causing damages to the thread.
 3. Keep all hardware parts out of reach of children.

NOTE : THE LIST AND QUANTITY SHOWN ARE FOR 1 UNIT ASSEMBLY.

PARTS LIST		
ITEM	DESCRIPTION	QTY
A	HEADBOARD	1 PC
B	FOOTBOARD	1 PC
C	SIDE RAIL	2 PCS
D	CENTER RAIL	1 PC
E	CENTER SUPPORT LEG	3 PCS
F	SLAT	1 SET
G	BED LEG	4 PCS

HARDWARE LIST		
ITEM	DESCRIPTION	QTY
1	JCBB BOLT M6 x 20mm	8 PCS
2	JCBB BOLT M8 x 16mm	4 PCS
3	JCBB BOLT M8 x 30mm	4 PCS
4	M6 FLAT WASHER	8 PCS
5	M6 SPRING WASHER	8 PCS
6	WOOD SCREW M4 x 38mm	9 PCS
7	M4 ALLEN KEY (BALL SHAPE)	1 PC
8	M5 ALLEN KEY (BALL SHAPE)	1 PC
9	201 LEG BRACKET	4 PCS
10	WOOD SCREW M4 x 20mm	16 PCS
11	M8 FLAT WASHER	4 PCS
12	M8 SPRING WASHER	4 PCS
13	5/16" HEX NUT	4 PCS
14	SPANNER 13mm	1 PC

STEP 1

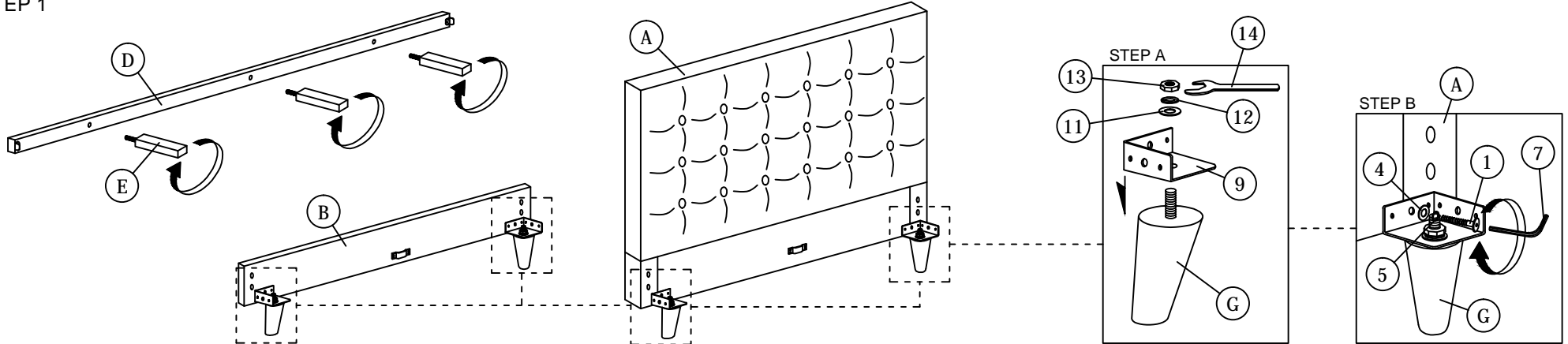

STEP 2

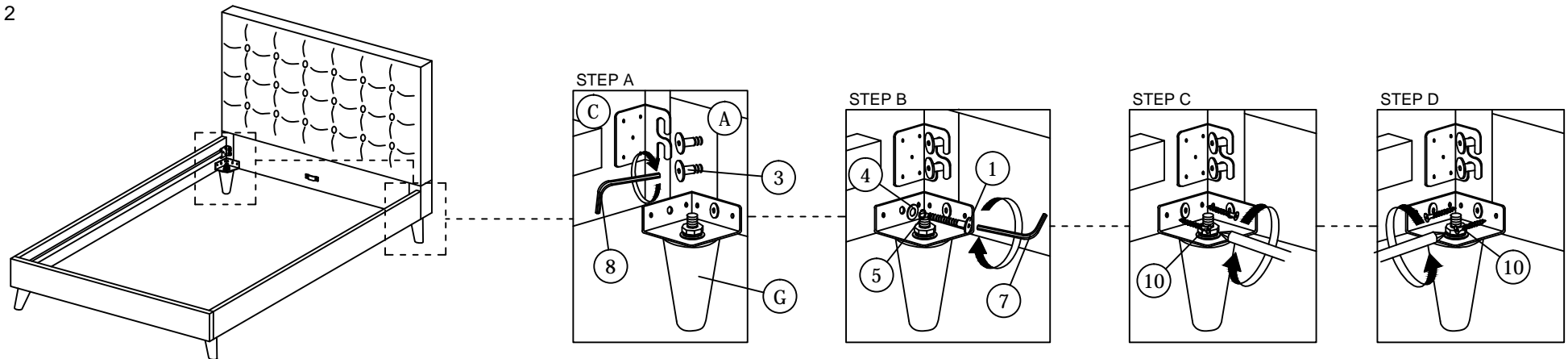

ASSEMBLY INSTRUCTIONS

STEP 3

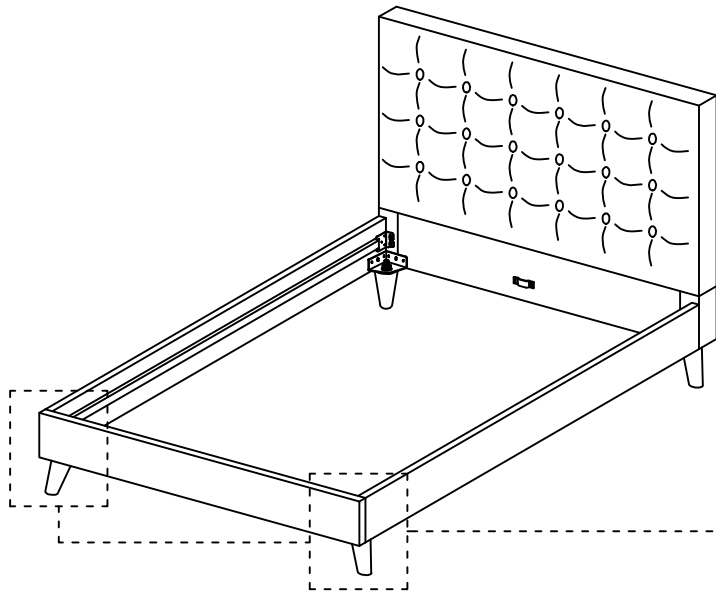

STEP A

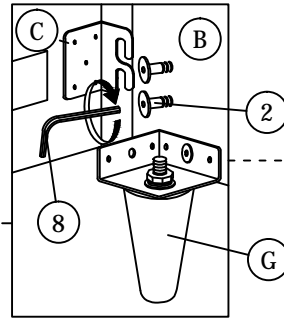

STEP B

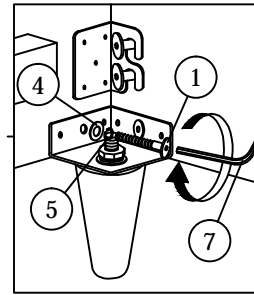

STEP C

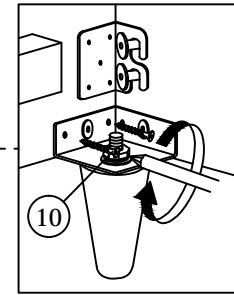

STEP D

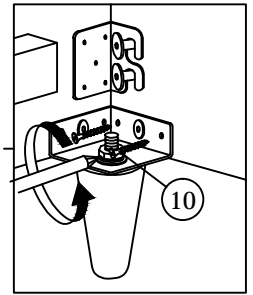

STEP 4

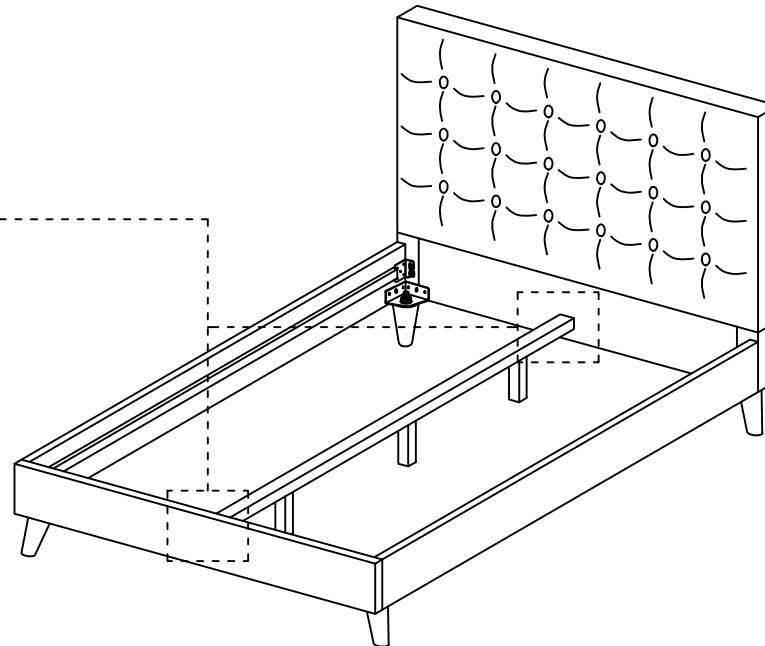
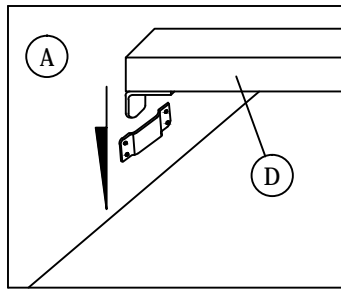

ASSEMBLY INSTRUCTIONS

STEP 5

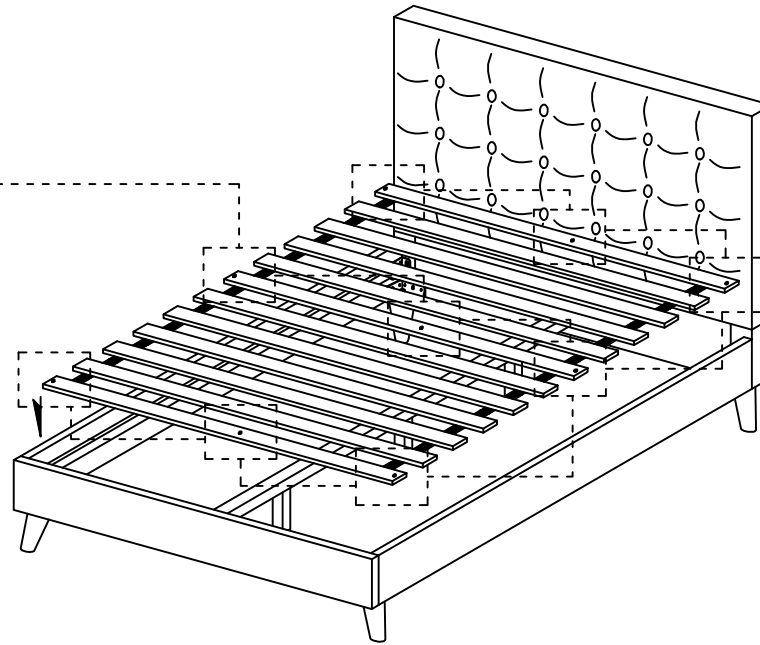
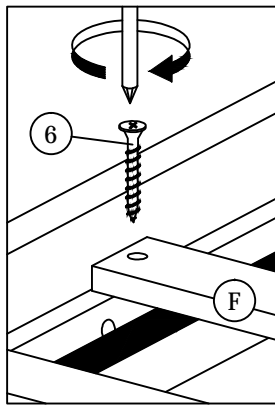

STEP 6

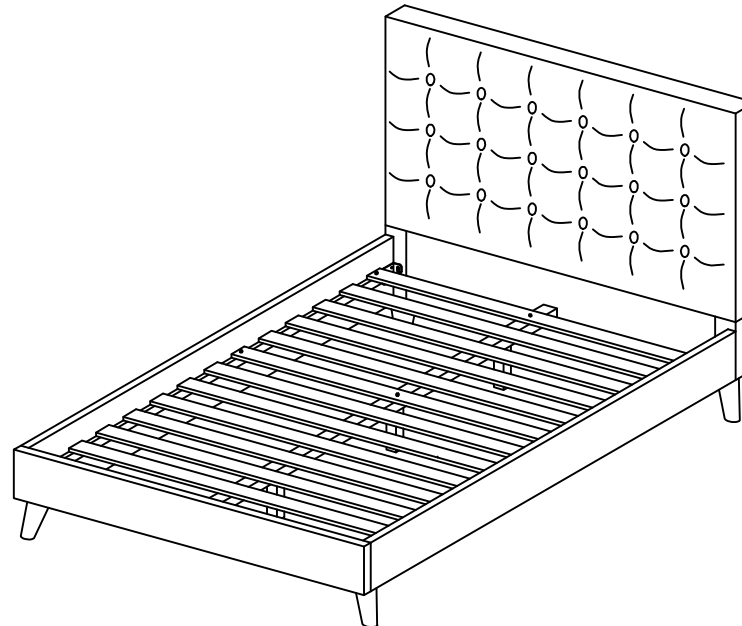

* When moving the bed position, the center support legs must be adjust to be straight to avoid any broken problem.