

ASSEMBLY INSTRUCTIONS

TWIN OVER FULL WITH DRAWERS AND STORAGE STAIRCASE

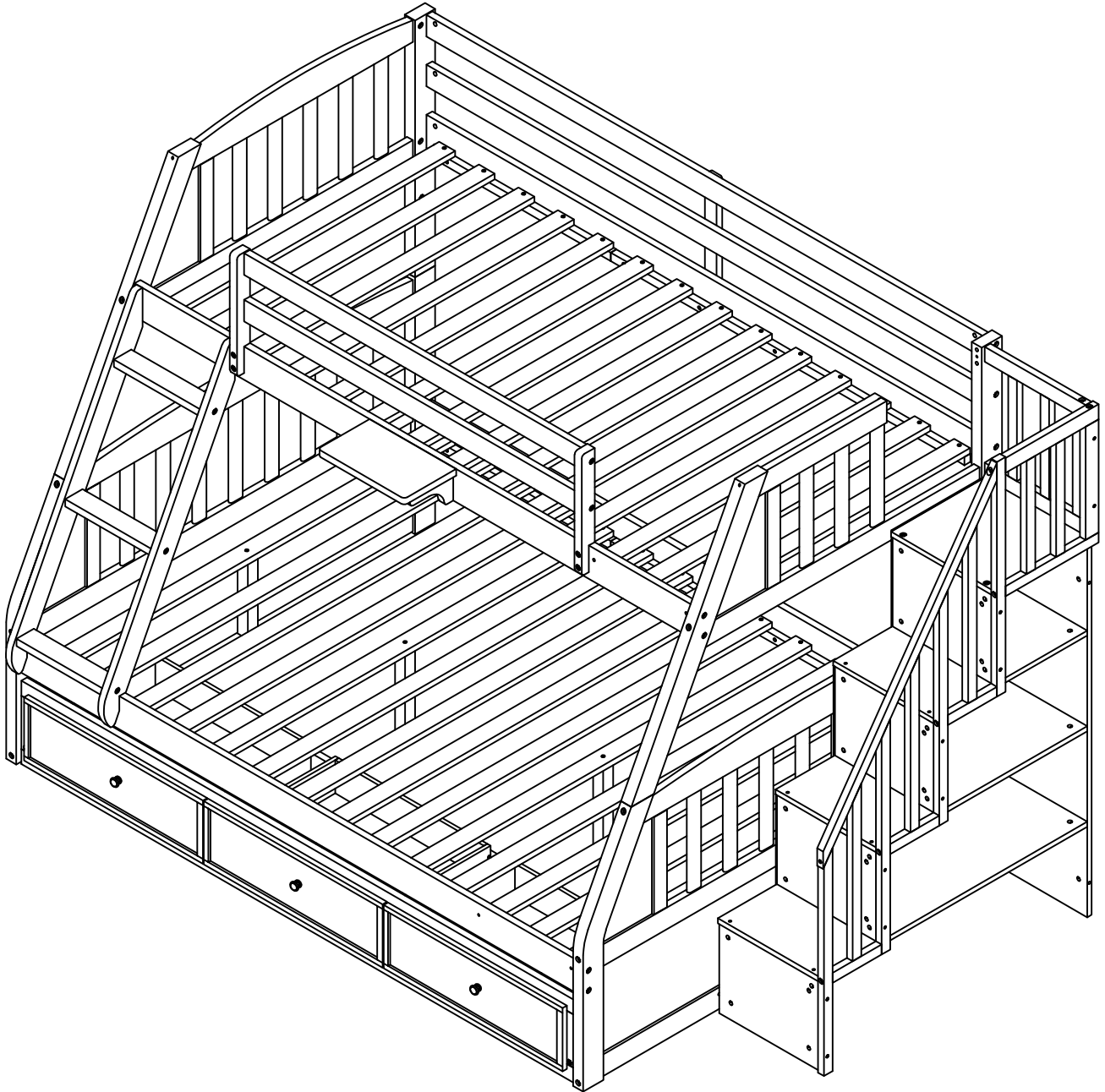

SAFETY WARNING

1. This bed is designed for use only mattress(es) meeting the following specifications on the upper bunk, and lower bunk:

Upper bunk

Bed Type	Length	Width	Thickness
Twin Standard	74" - 75"	38 1/2"	6"

Lower bunk







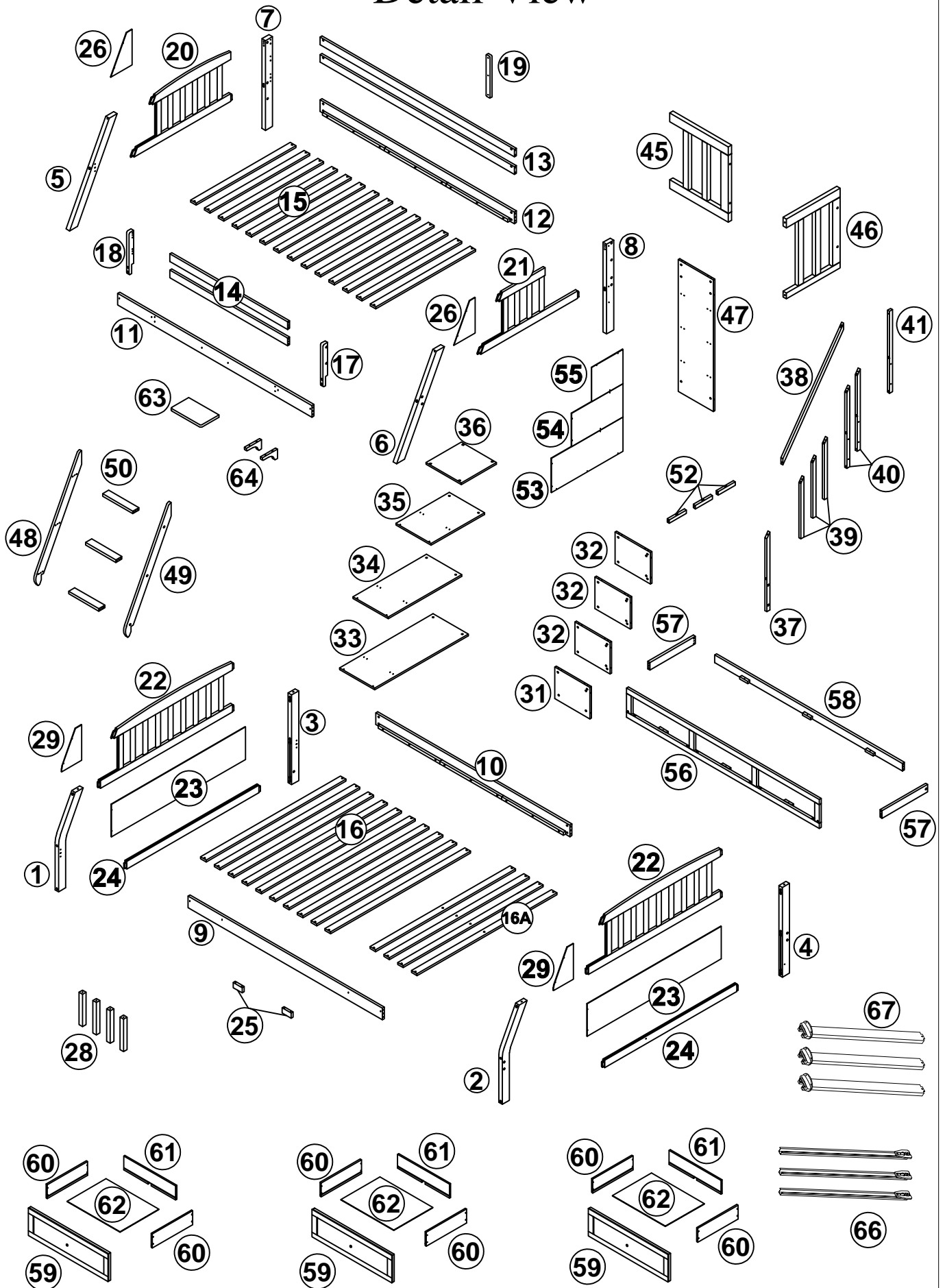



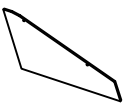

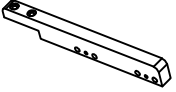
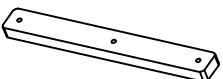
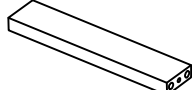

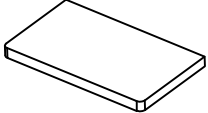
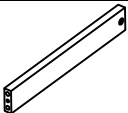

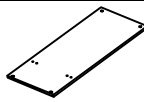
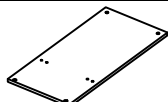
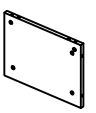
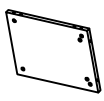
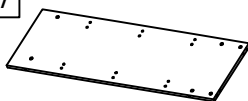
Bed Type	Length	Width	Thickness
Full Standard	74" - 75"	53 1/2"	6"

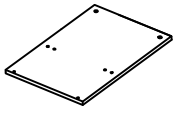
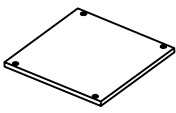
2. Replacement parts, including additional guardrails, may be obtained from any of our dealers.
3. Follow the information on the warnings appearing on the upper bunk bed end structure and on the carton. Do not remove warning label from bed.
4. Always use the recommended size mattresses or mattress supports, or both, to help prevent the likelihood of entrapment or falls.
5. Surface of the mattress must be at least 5 in. (127 mm) below the upper edge of guardrails.
6. Do not allow children under 6 years of age to use the upper bunk.
7. Periodically check and ensure that the guardrail, ladder, and other components are in their proper position, free from damage, and that all connectors are tight.
8. Do not allow horseplay on or under the bed and prohibit jumping on the bed
9. Always use the ladder for entering and leaving the upper bunk.
10. Do not use substitute parts. Contact the manufacturer or dealer for replacement parts.
11. Use of a night light may provided added safety precaution for a child using the upper bunk.
12. Always use guardrails on both long sides of the upper bunk. If the bunk bed will be placed next to the wall, the guardrail that runs the full length of the bed should be placed against the wall to prevent entrapment between the bed and wall.
13. The use of water or sleep flotation mattresses is prohibited.
14. **STRANGULATION HAZARD** – Never attach or hang items to any part of the bunk bed that are not designed for use with the bed; for example, but not limited to, hook, belts and jump ropes.
15. Keep these instructions for future reference
16. We recommend assembling your bunk bed on a shipping carton to protect your floor or carpet
17. Be certain all staples are out of the box before beginning assembly on the shipping carton
18. Prohibit more than one person on upper bunk

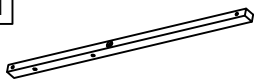

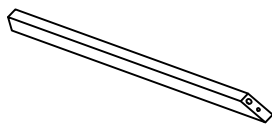
Detail View

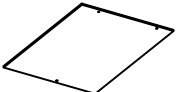
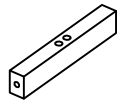

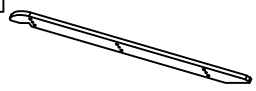
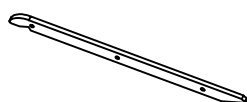



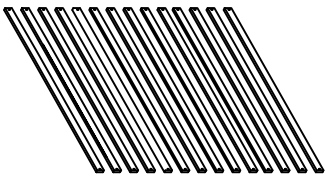
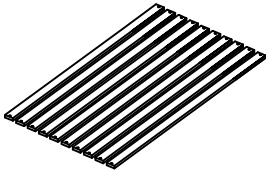

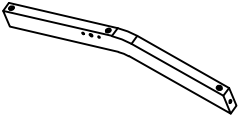
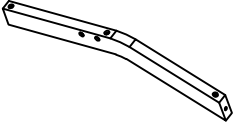
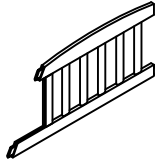
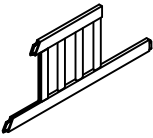
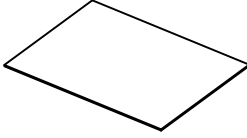
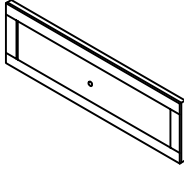
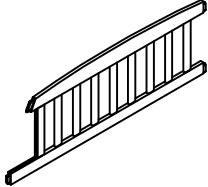
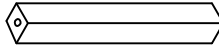
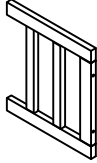
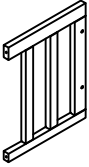
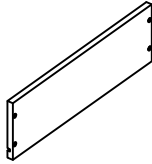
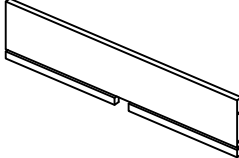
PART LISTS

26  Upper panel - (2pcs)	29  Bottom panel - (2pcs)	17  Guardrail front posts (Right) - (1pc)	18  Guardrail front posts (Left) - (1pc)
19  Back Guardrail reinforce bar - (1pc)	50  Ladder steps - (3pcs)	64  Support shelf - (2pcs)	63  Shelf - (1pc)
57  Drawer blocking hip - (2pcs)	25  Wood block - (2pcs)	33  Lower horizontal plank - (1pc)	34  Horizontal midboard - (1pc)
31  Bottom plank - (1pc)	32  Middle plank - (3pcs)	47  Plank standing behind - (1pc)	37  Bottom bar - (1pc)
35  Upper middle plank - (1pc)	36  Top plank - (1pc)	40  Upper bar - (2pcs)	41  Top bar - (1pc)
38  Handrail - (1pc)	39  Middle bar - (3pcs)	54  Middle panel (1pc)	55  Top panel - (1pc)
52  Balustrade - (3pcs)	53  Bottom panel - (1pc)	48  Ladder rail Left - (1pc)	49  Ladder rail Right - (1pc)

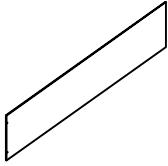
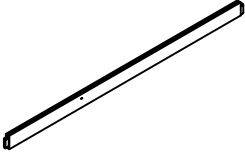

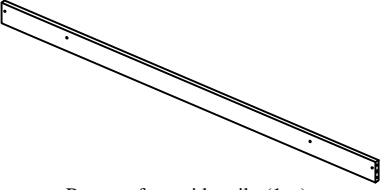
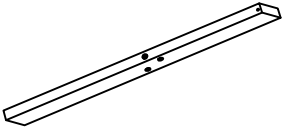
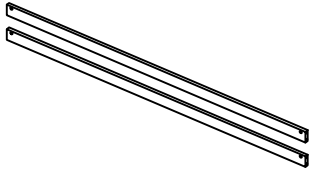

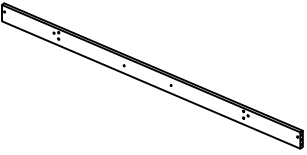
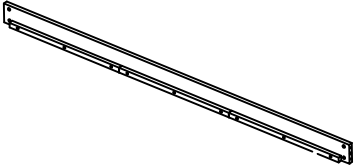
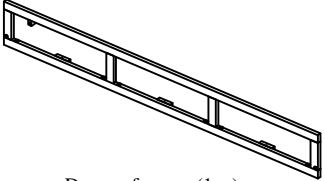
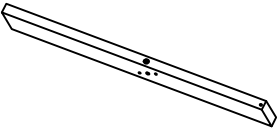

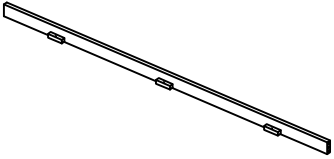
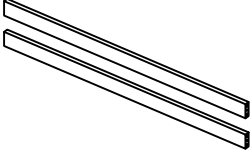
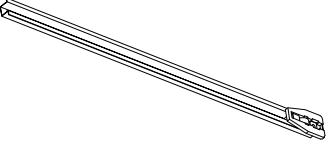
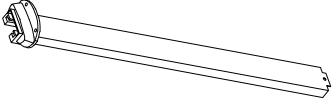

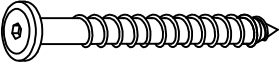
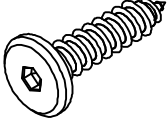

PART LISTS

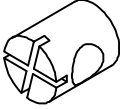
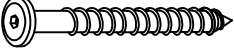
<p>15</p>  <p>Upper slats - (14pcs)</p>	<p>16</p>  <p>Bottom slats - (10pcs)</p>	<p>16A</p>  <p>Bottom 3 holes slats - (4pcs)</p>
<p>1</p>  <p>Bottom front leg (Left) - (1pc)</p>	<p>2</p>  <p>Bottom front leg (Right) - (1pc)</p>	<p>20</p>  <p>Upper Frame left- 1pc</p>
<p>21</p>  <p>Upper Frame Right- 1pc</p>	<p>62</p>  <p>Bottom drawer - (3pcs)</p>	<p>59</p>  <p>Drawer front - (3pcs)</p>
<p>22</p>  <p>Bottom Frame - (2pcs)</p>	<p>28</p>  <p>Center support leg - (4pcs)</p>	<p>45</p>  <p>Stair frame (back) (1pc)</p>
<p>46</p>  <p>Stair frame (right) (1pc)</p>	<p>60</p>  <p>Drawer side panels - (6pcs)</p>	<p>61</p>  <p>Drawer Back panels - (3pcs)</p>

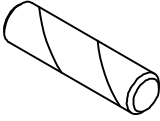
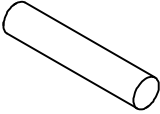
PART LISTS

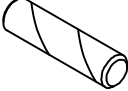
<p>23</p>  <p>Bottom panel - (2pcs)</p>	<p>24</p>  <p>Bottom rail - (2pcs)</p>	<p>4</p>  <p>Bottom back leg (Right) - (1pc)</p>
<p>10</p>  <p>Bottom back side rail - (1pc)</p>	<p>9</p>  <p>Bottom front side rail - (1pc)</p>	<p>6</p>  <p>Upper front leg (Left) - (1pc)</p>
<p>13</p>  <p>Back upper side rail - (2pcs)</p>	<p>3</p>  <p>Bottom back leg (Left) - (1pc)</p>	<p>7</p>  <p>Upper front leg (Right) - (1pc)</p>
<p>11</p>  <p>Front upper side rail - (1pc)</p>	<p>12</p>  <p>Back upper side rail - (1pc)</p>	<p>56</p>  <p>Drawer frame - (1pc)</p>
<p>5</p>  <p>Upper front leg (Right) - (1pc)</p>	<p>8</p>  <p>Upper back leg (Left) - (1pc)</p>	<p>58</p>  <p>Drawer stop bar - (1pc)</p>
<p>14</p>  <p>Front upper side rails - (2pcs)</p>	<p>66</p>  <p>Kenlin glide (+) - (3pcs)</p>	<p>67</p>  <p>Kenlin glide (-) - (3pcs)</p>

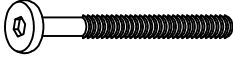
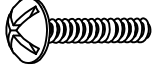
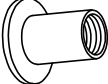
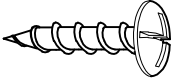
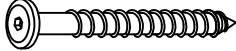
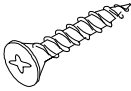
HARDWARE LISTS

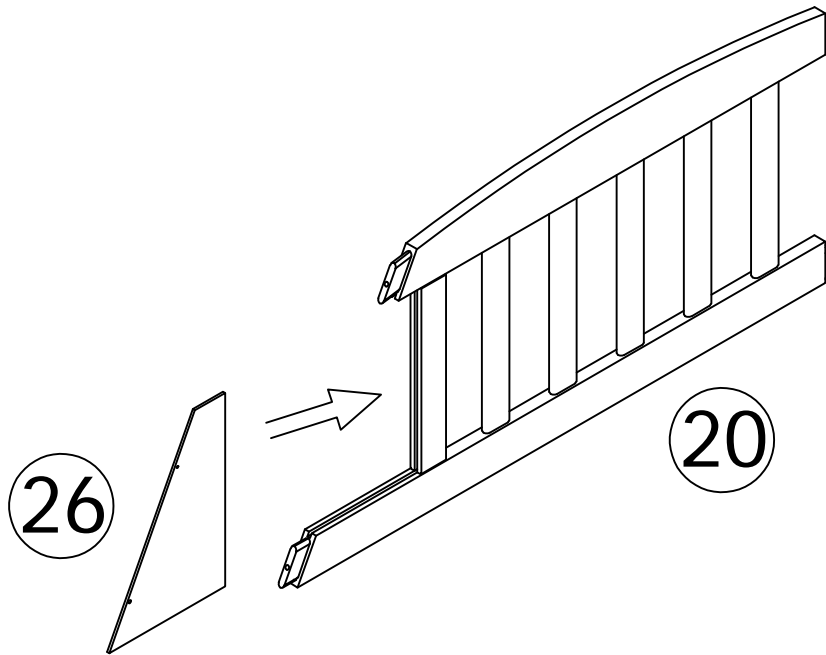

<p>A</p>  <p>Hex-Head bolt: Ø1/4**65mm - (5pcs)</p>	<p>B</p>  <p>Hex-Head bolt: Ø6**100mm - (19pcs)</p>	<p>C</p>  <p>Hex-Head bolt: Ø6**30mm - (5pcs)</p>
<p>D</p>  <p>Hex-Head bolt: Ø6**85mm - (1pc)</p>	<p>E</p>  <p>Hole bolt: Ø1/4**9.5*12mm - (57pcs)</p>	<p>F</p>  <p>Hex-Head bolt: Ø6**50mm - (18pcs)</p>
<p>G</p>  <p>Allen key - (1pc)</p>	<p>H</p>  <p>Wood dower: Ø10*30 - (44pcs)</p>	<p>J</p>  <p>Metal dower: Ø10*90mm - (4pcs)</p>
<p>K</p>  <p>Screw: Ø4*30mm (87pcs)</p>	<p>R</p>  <p>Wood dower: Ø8*30 - (34pcs)</p>	<p>P</p>  <p>Hex-Head bolt: Ø1/4**30mm - (8pcs)</p>
<p>V</p>  <p>Holder - (3pcs)</p>	<p>Z</p>  <p>Hex-Head bolt: Ø1/4**85mm - (22pcs)</p>	<p>Y</p>  <p>Bolts: 5/32**25mm - (3pcs)</p>
<p>Q</p>  <p>Knot: Ø1/4" - (4pcs)</p>	<p>O</p>  <p>Umbrella head screw: Ø3.5*15mm - (25pcs)</p>	<p>X</p>  <p>Hex-Head bolt: Ø6**70mm - (9pcs)</p>
<p>W</p>  <p>Screw: Ø4*25mm - (6pcs)</p>	<p>N</p>  <p>Hex-Head bolt: Ø1/4**50mm - (22pcs)</p>	<p>L</p>  <p>Hex-Head bolt: Ø1/4**70mm - (8pcs)</p>

Step 1

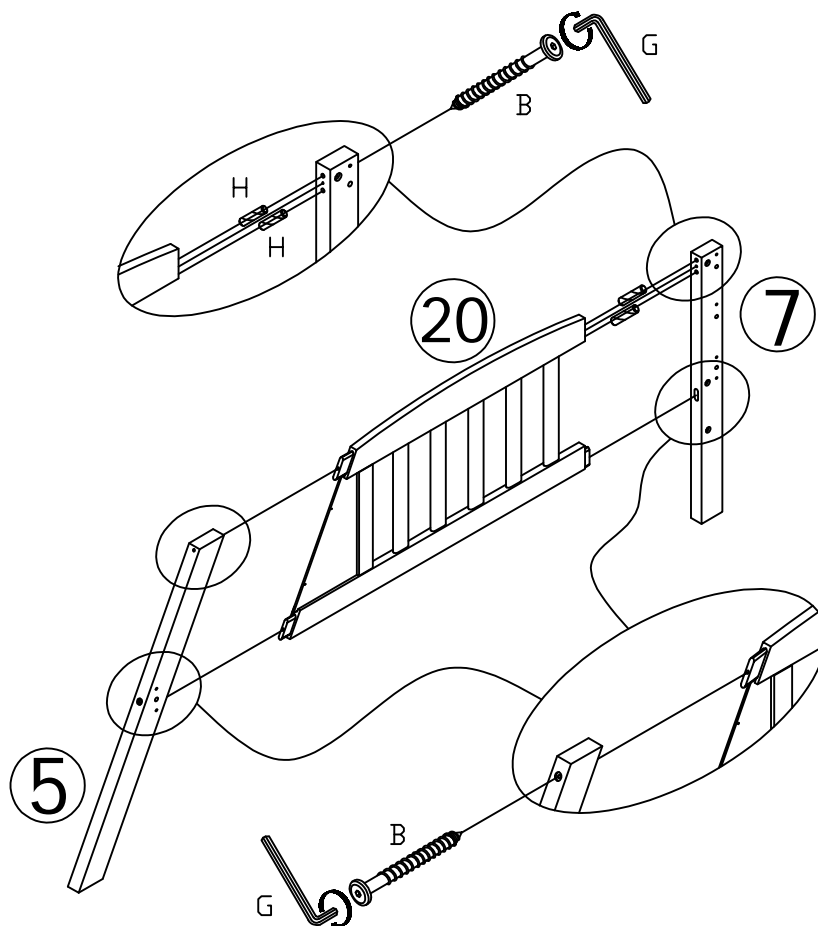

Step 2



H	B
	
2pcs	4pcs

Step 3

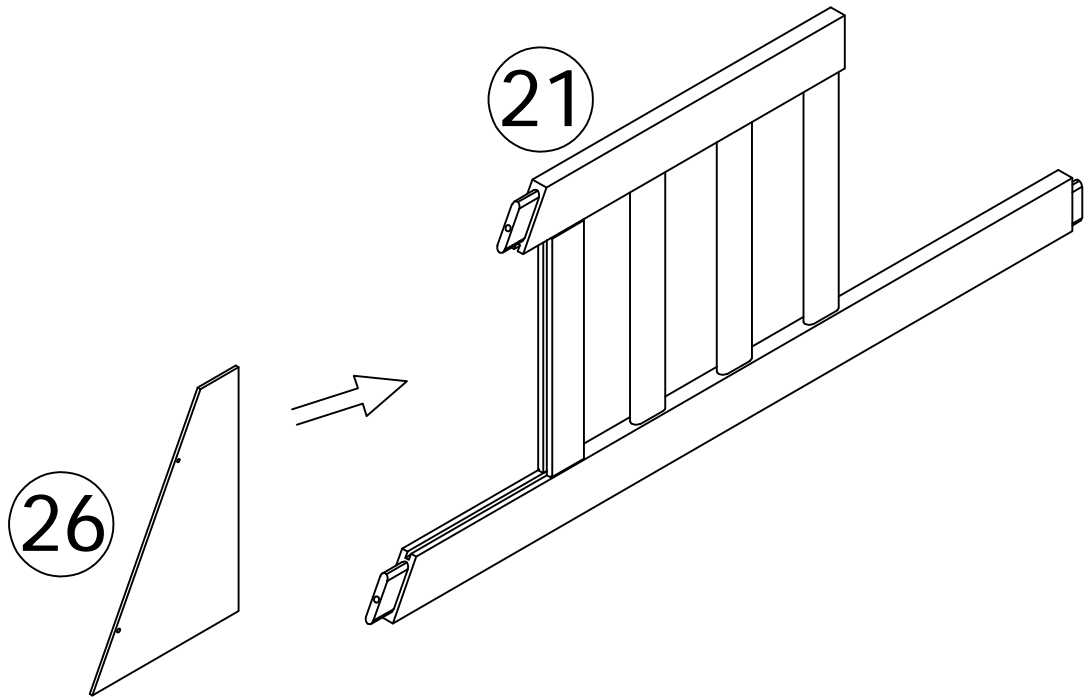

Step 4

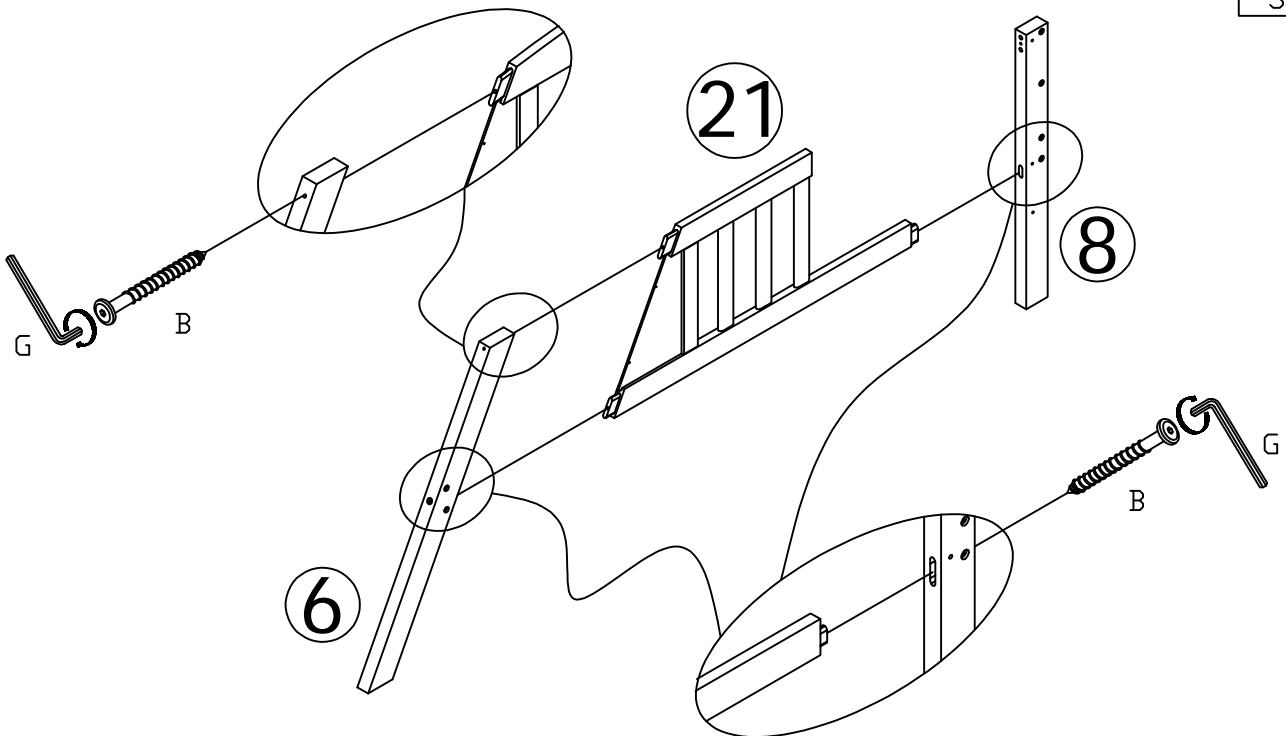
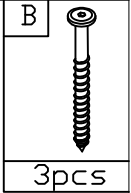

Step 5

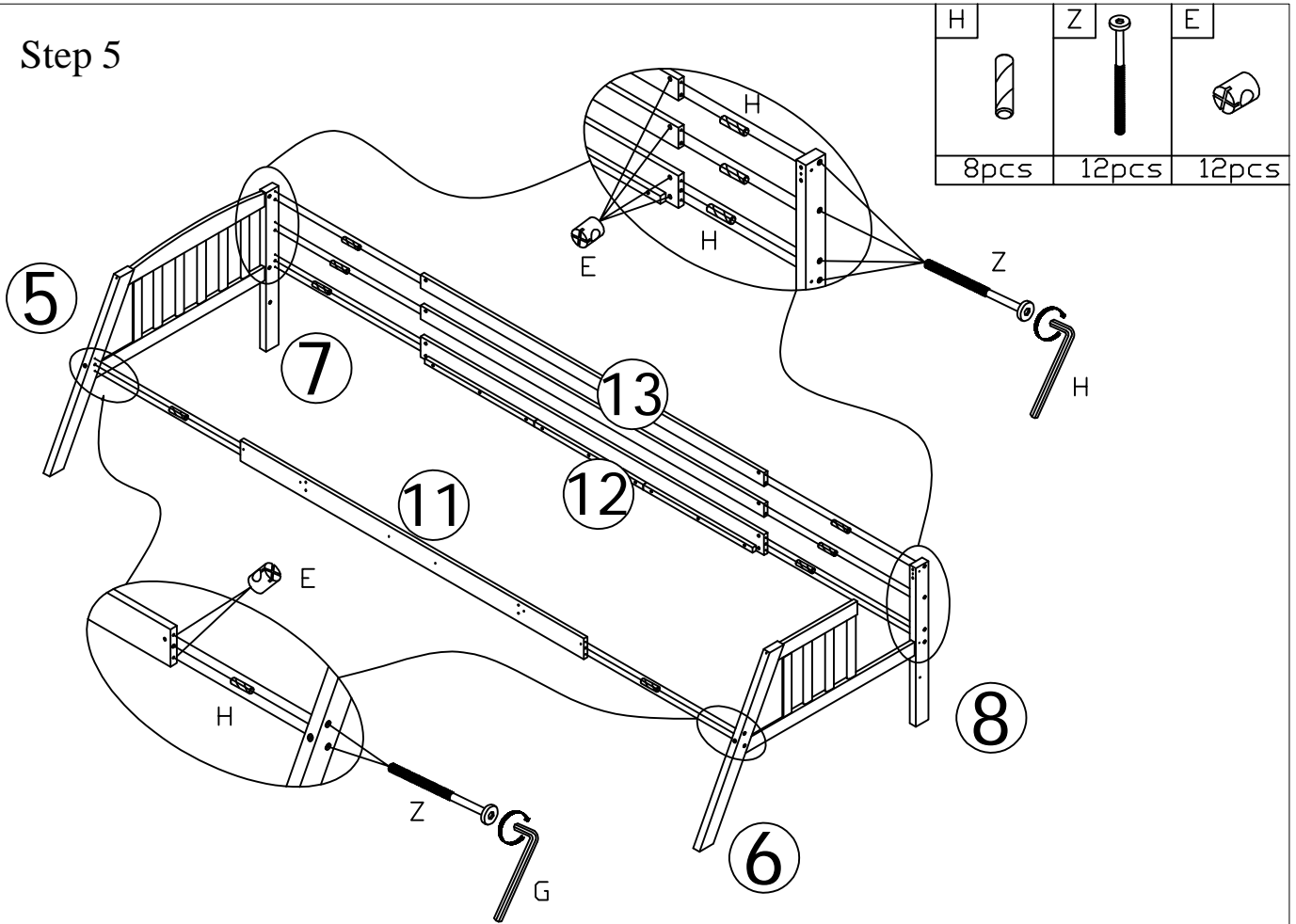

Step 6

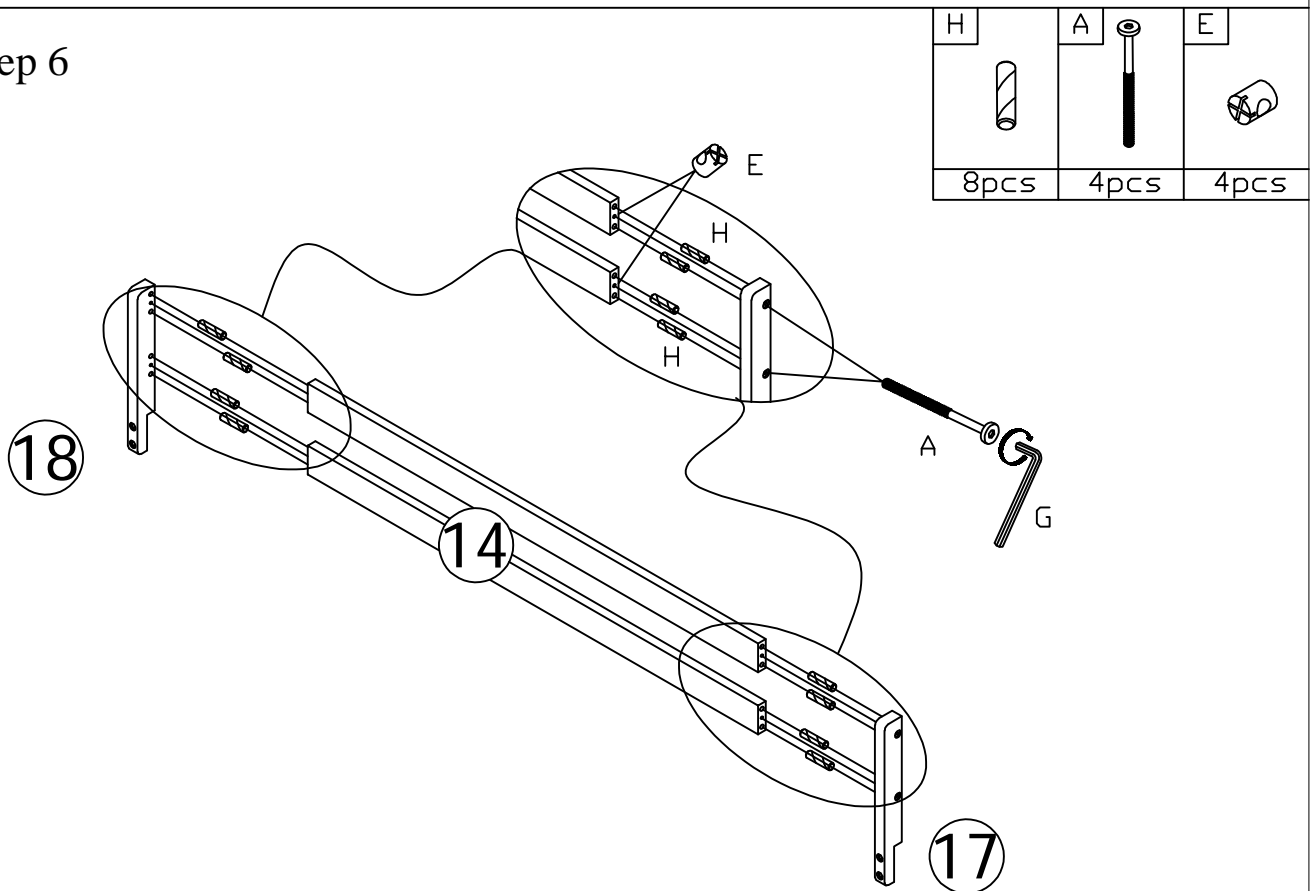

Step 7

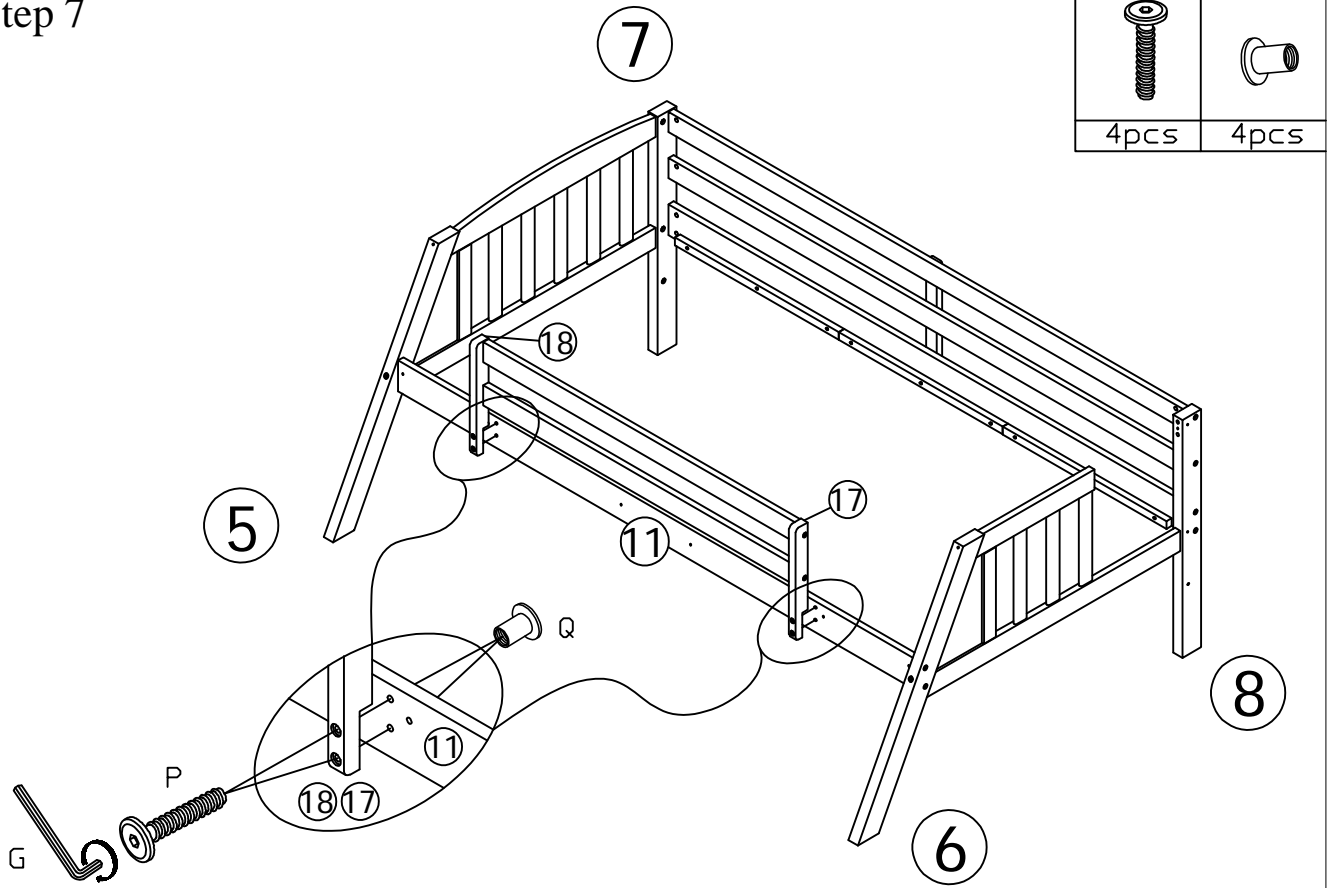

Step 8

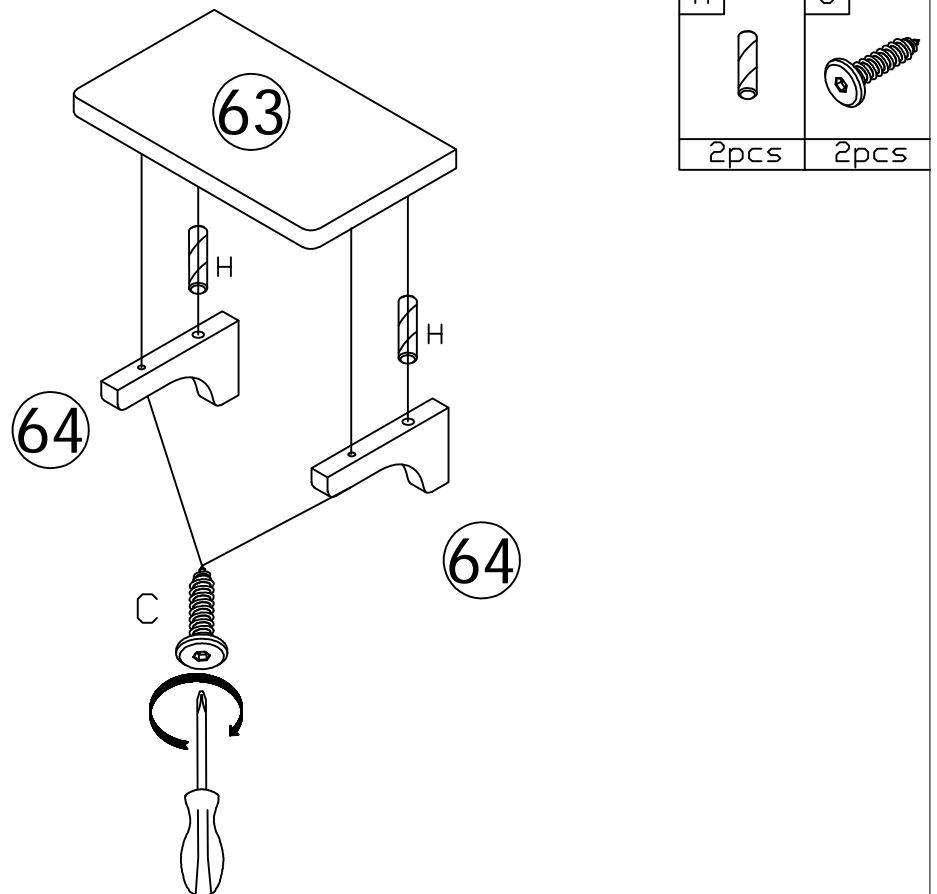

Step 9

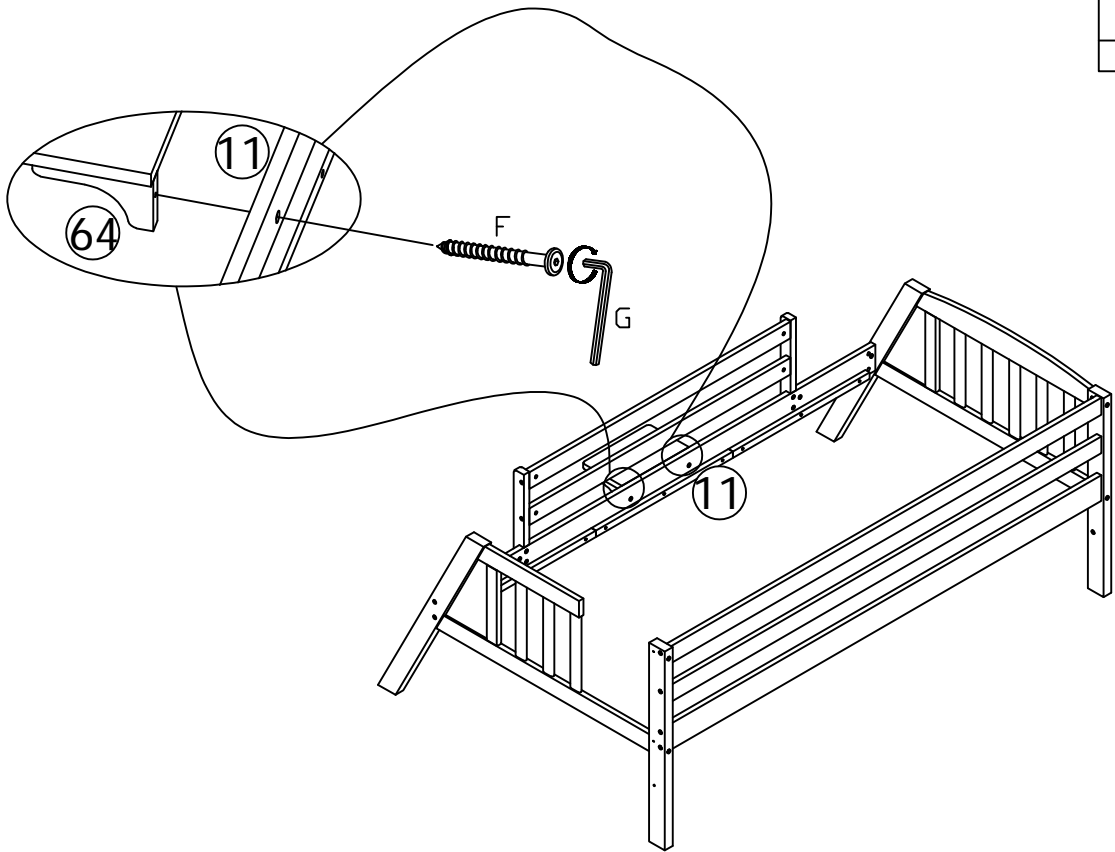
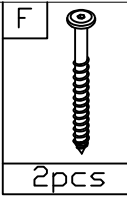

Step 10

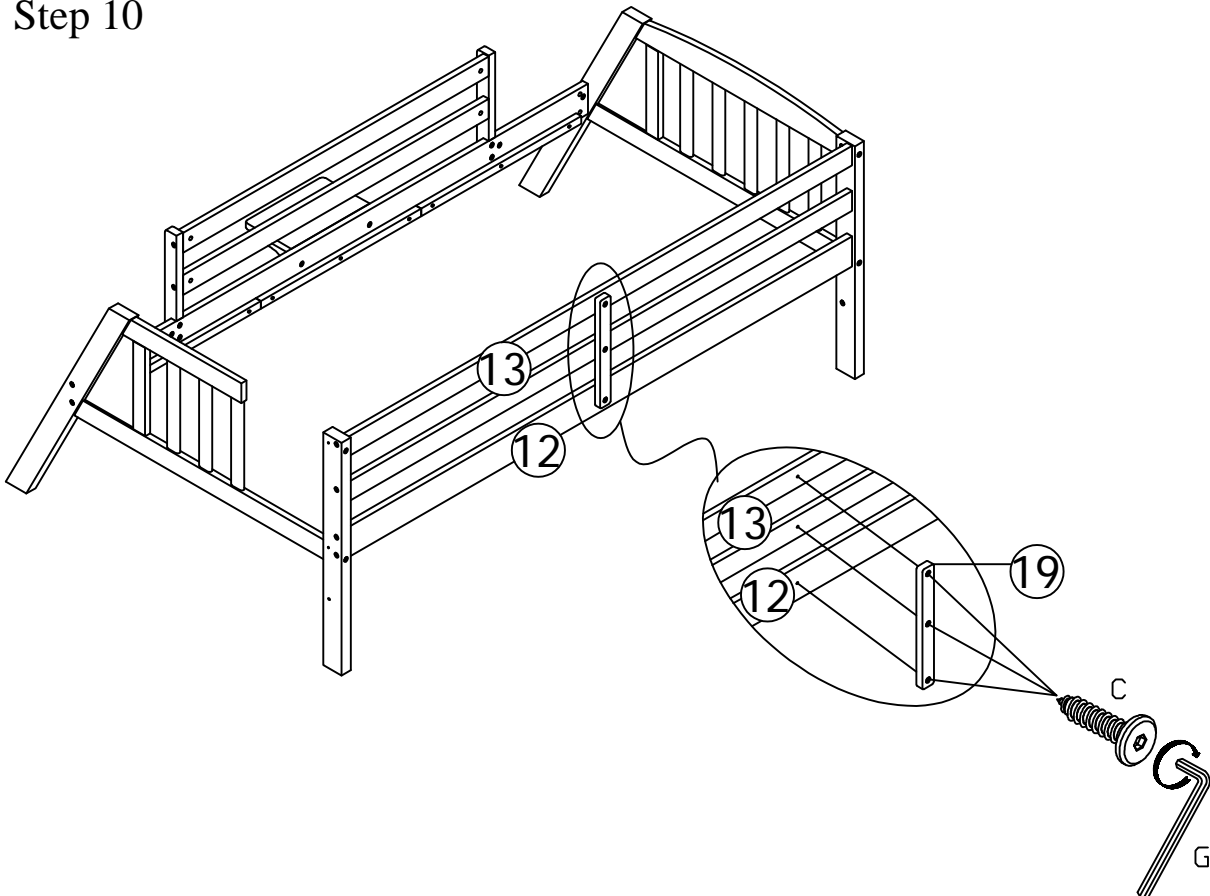
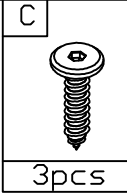

Step 11

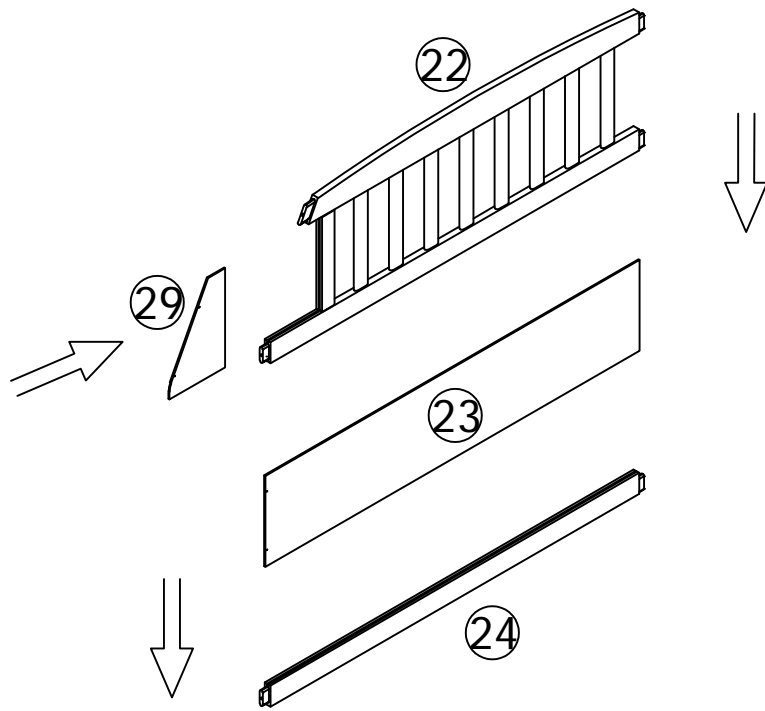

Step 12

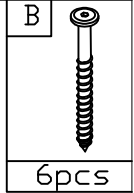
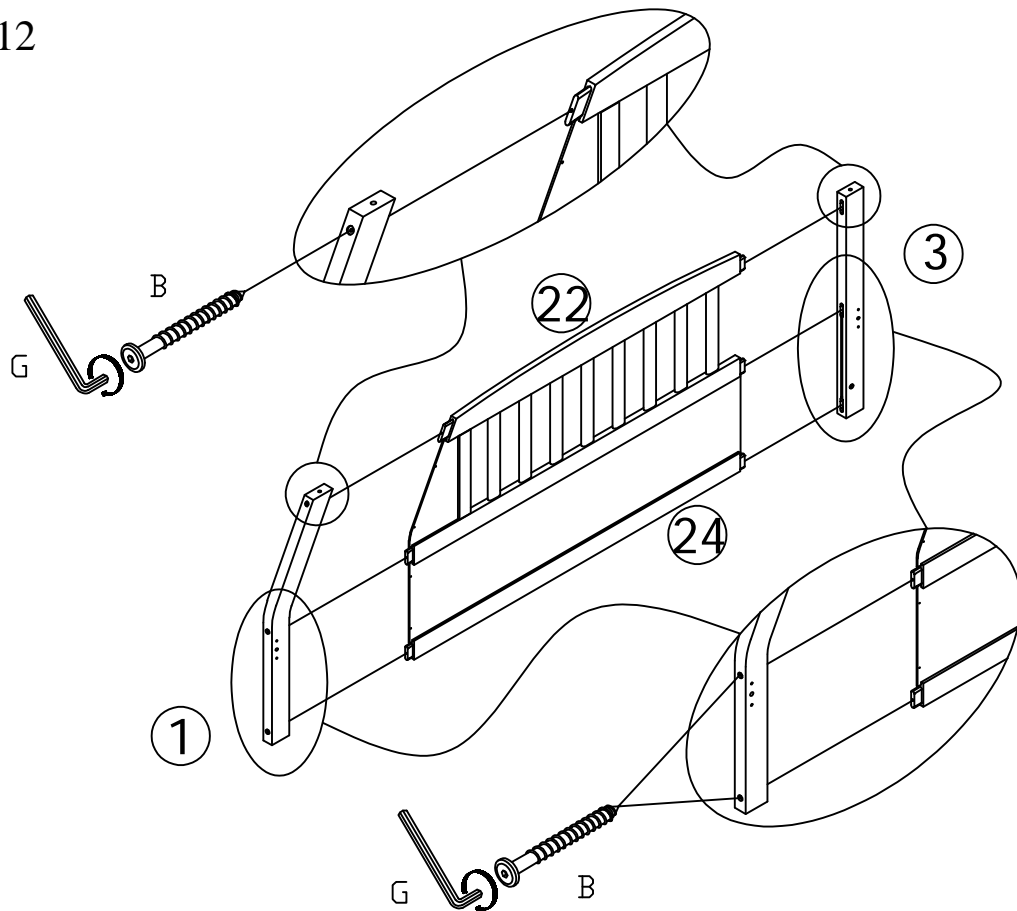

Step 13

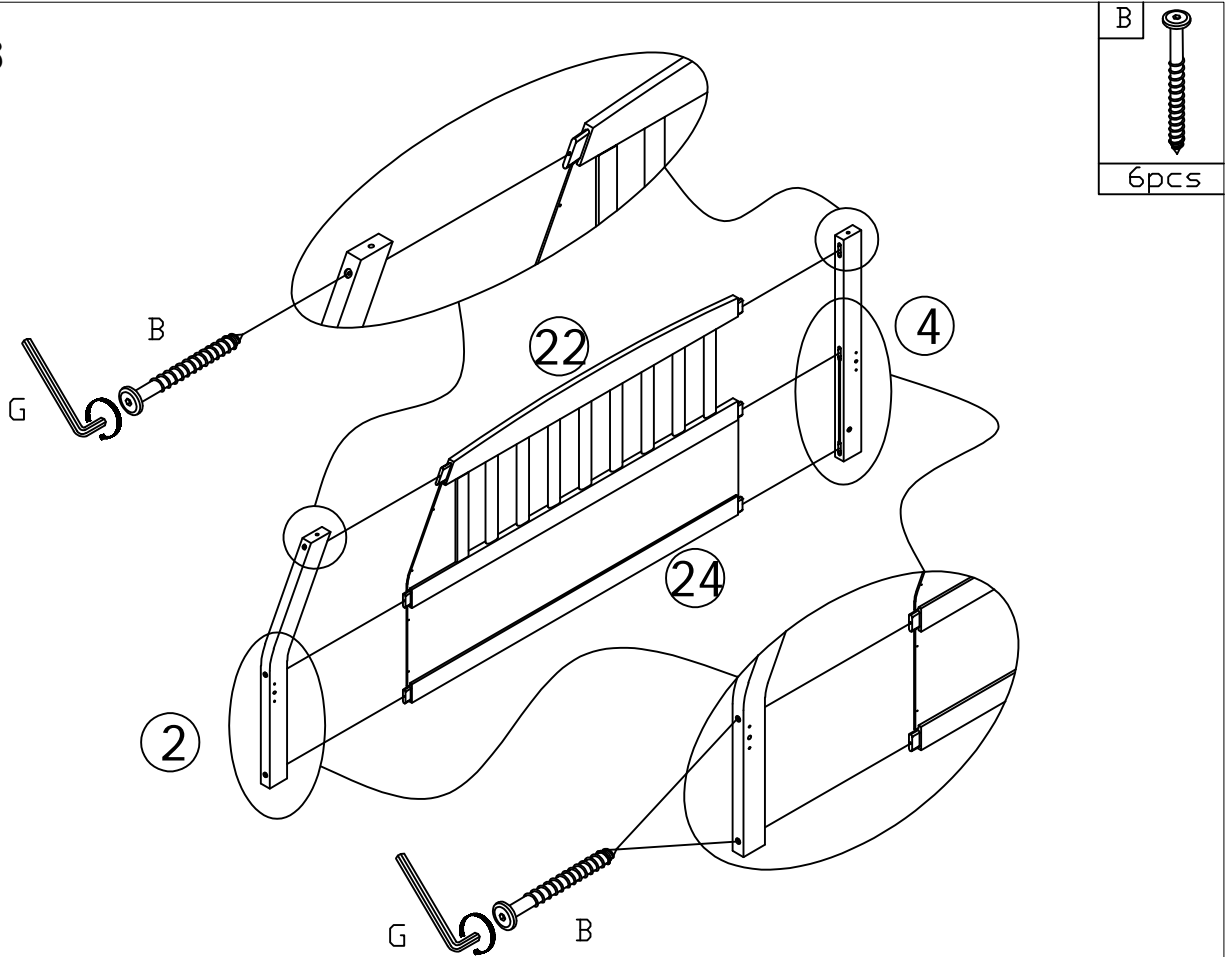

Step 14

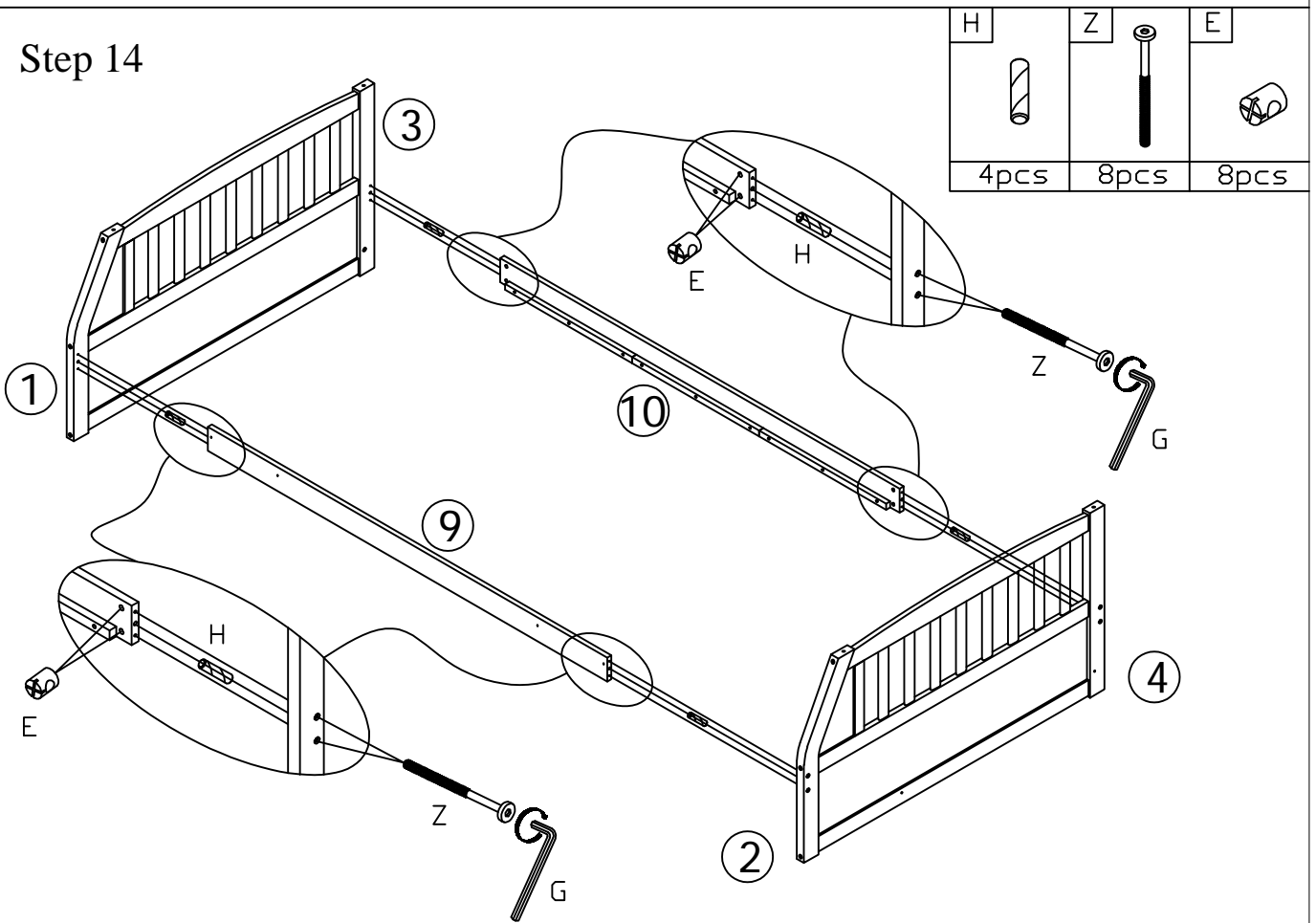

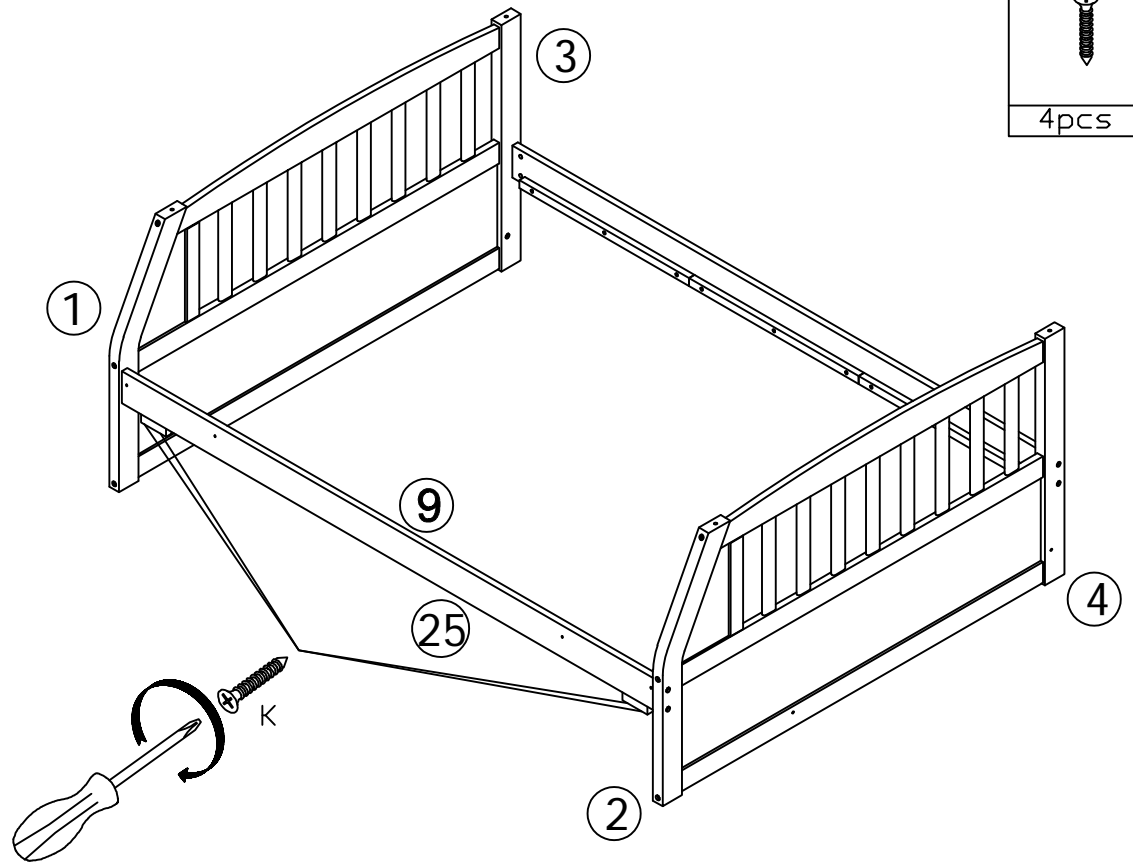

Step 15

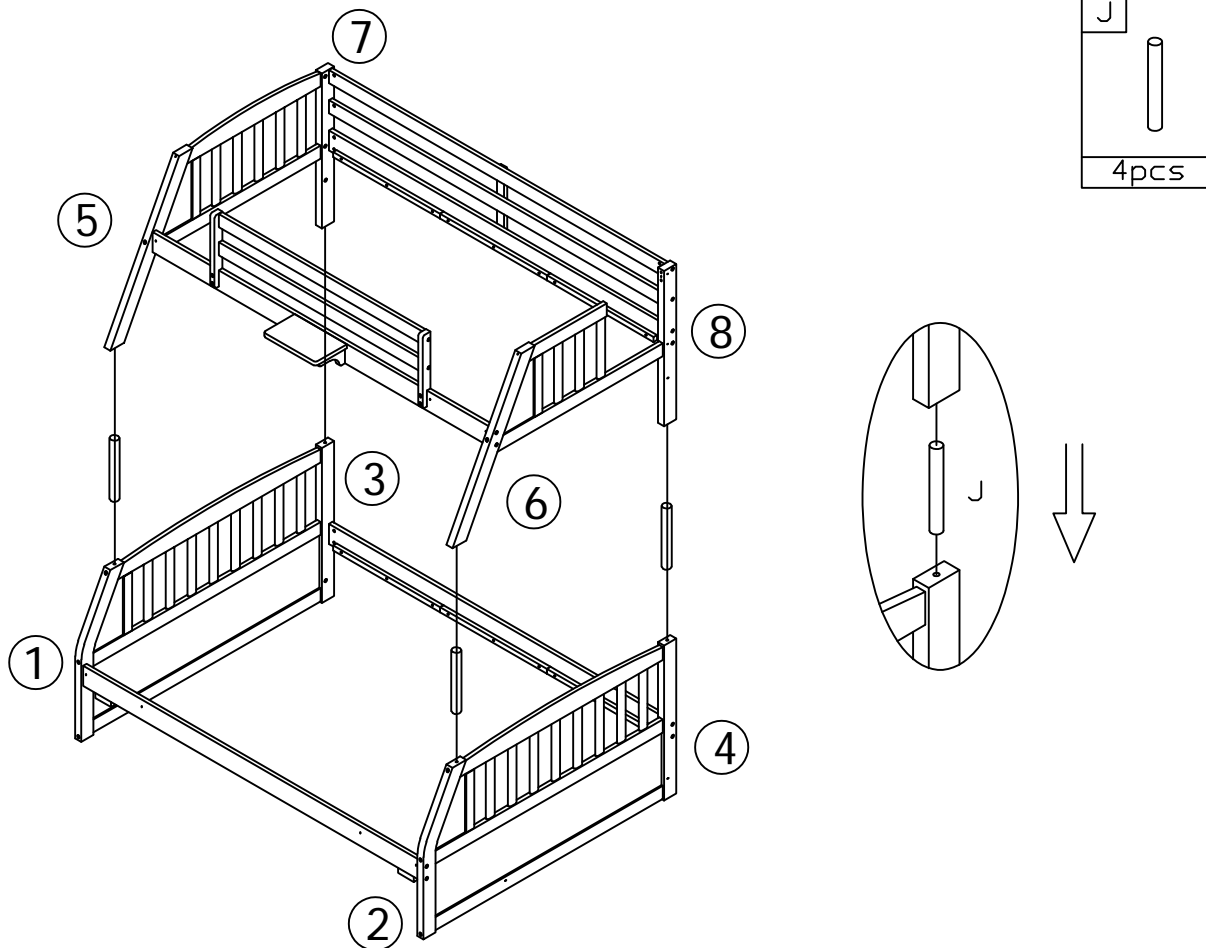

Step 16



Step 17

H	F
	
12pcs	6pcs

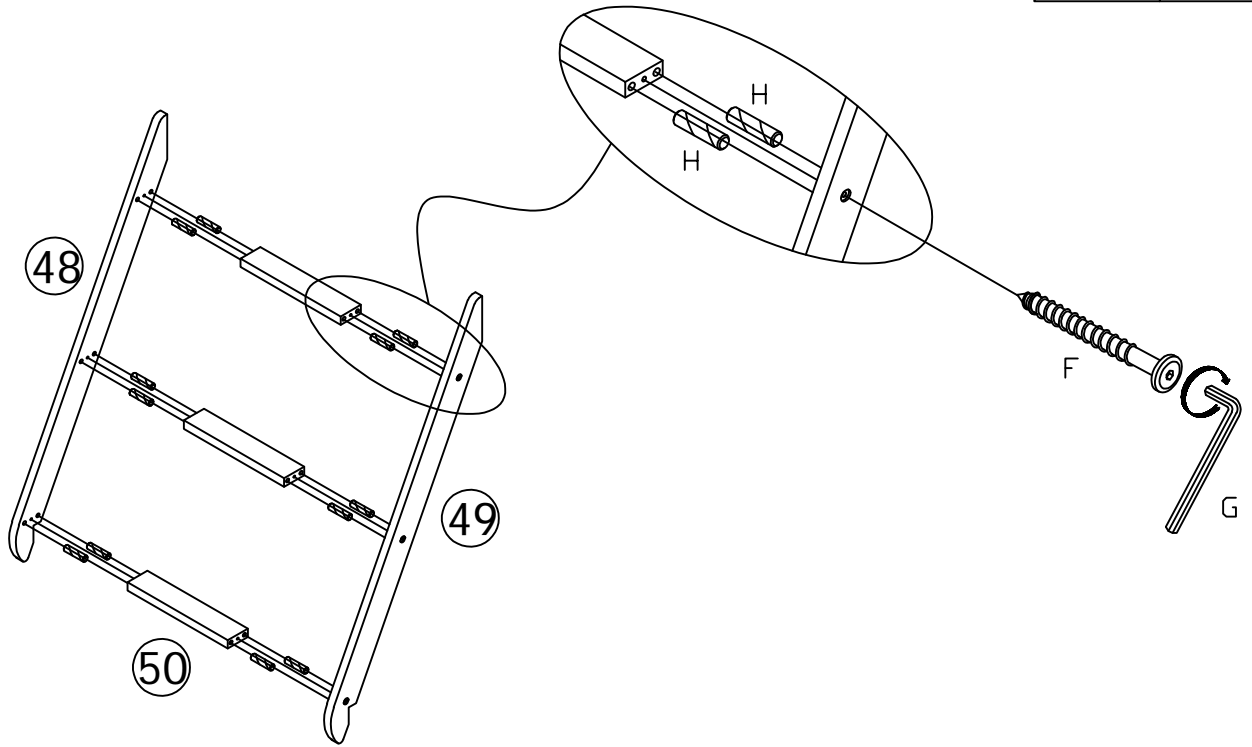

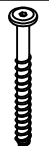

Step 18

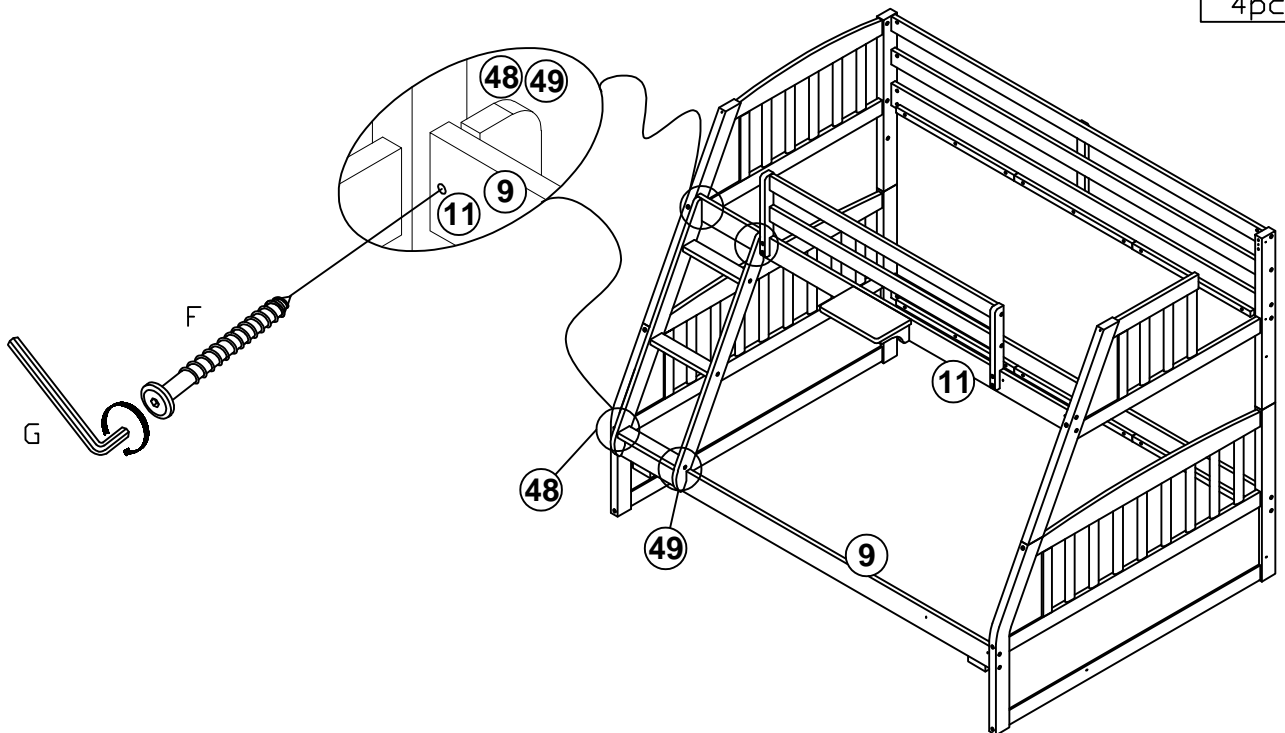
F

4pcs



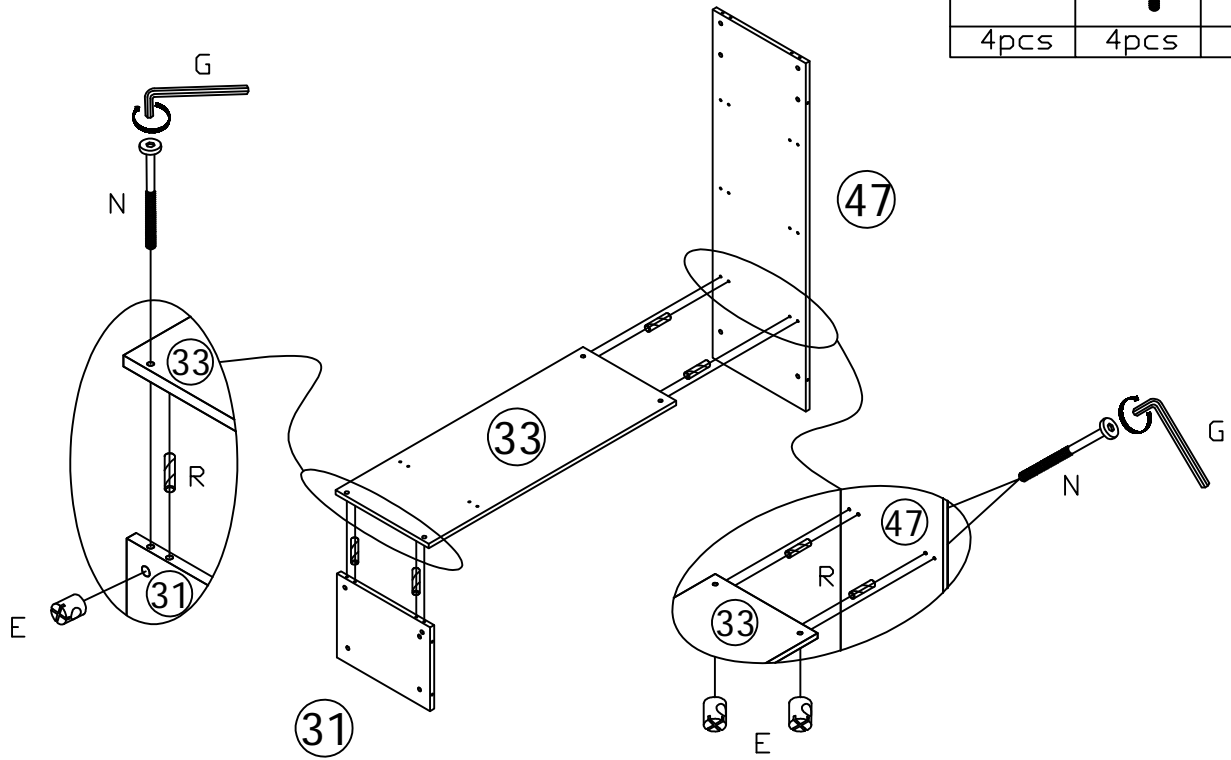

Step 19

R	N	E
		
4pcs	4pcs	4pcs





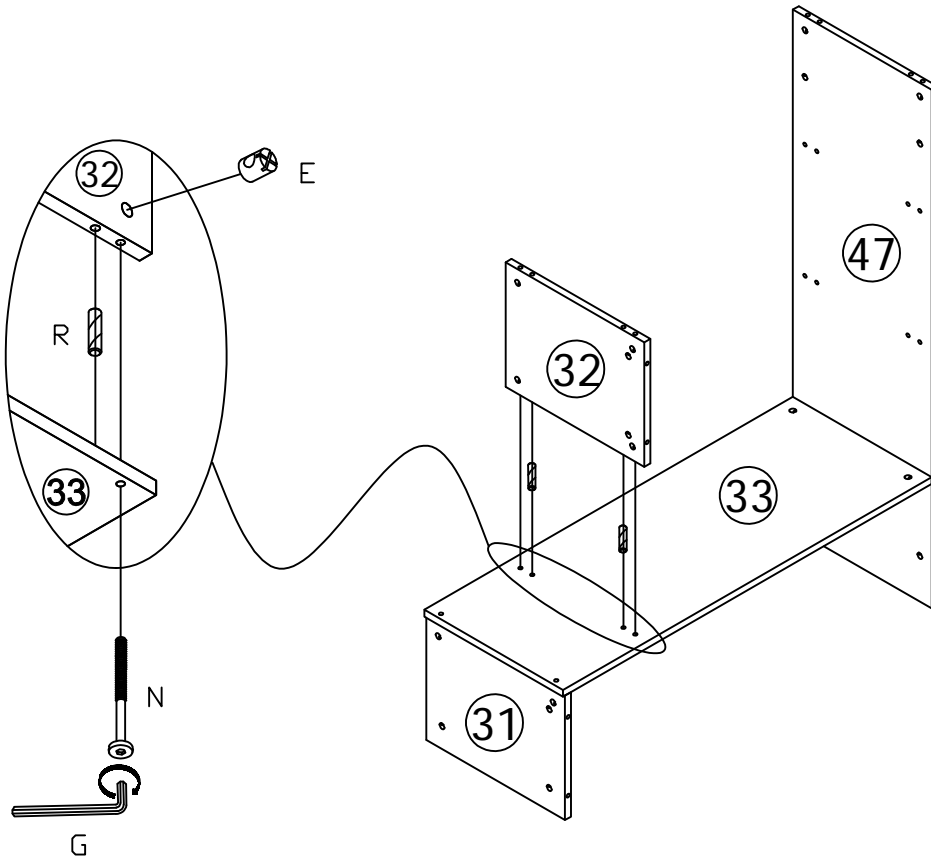

Step 20

R	N	E
		
2pcs	2pcs	2pcs

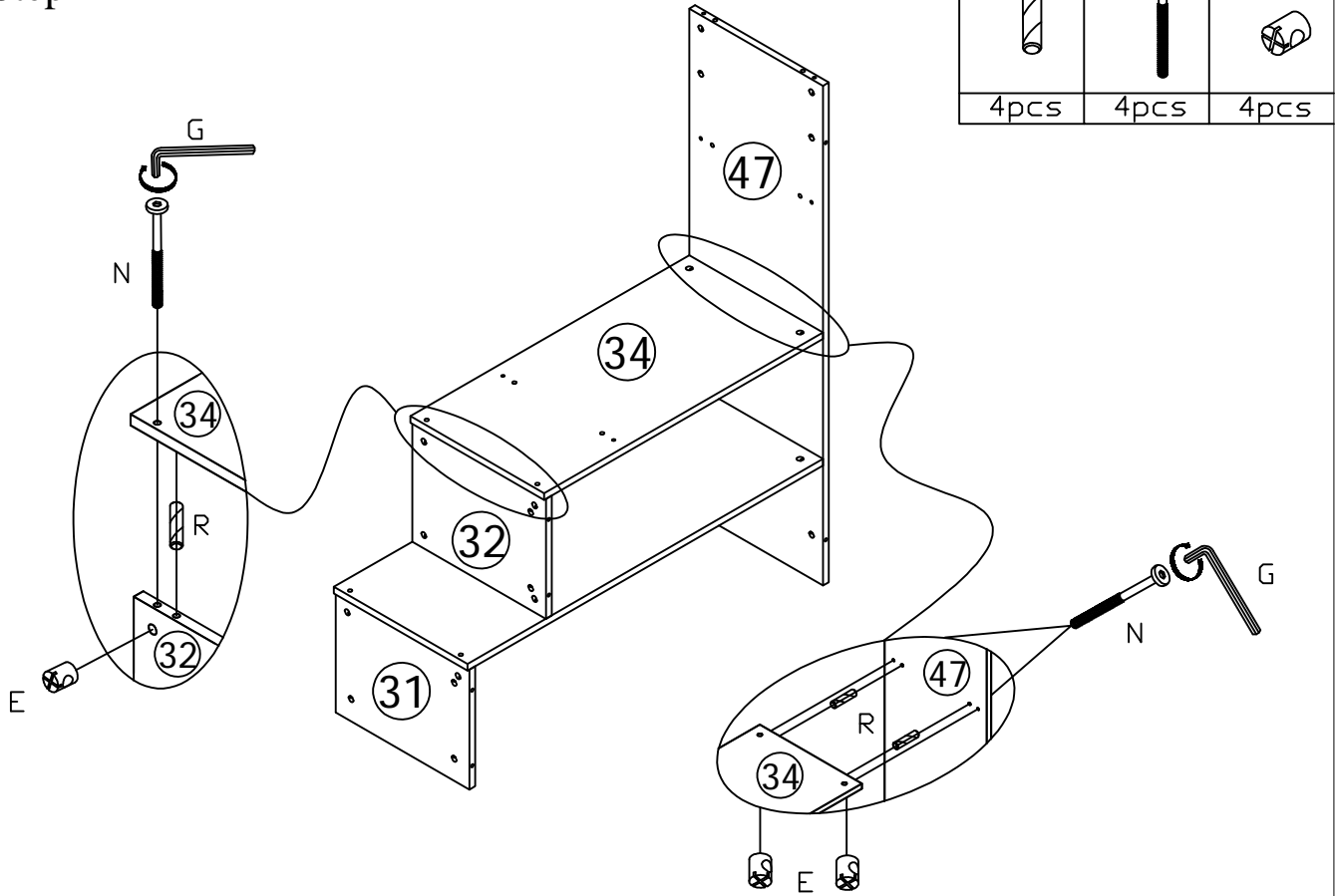





Step 21

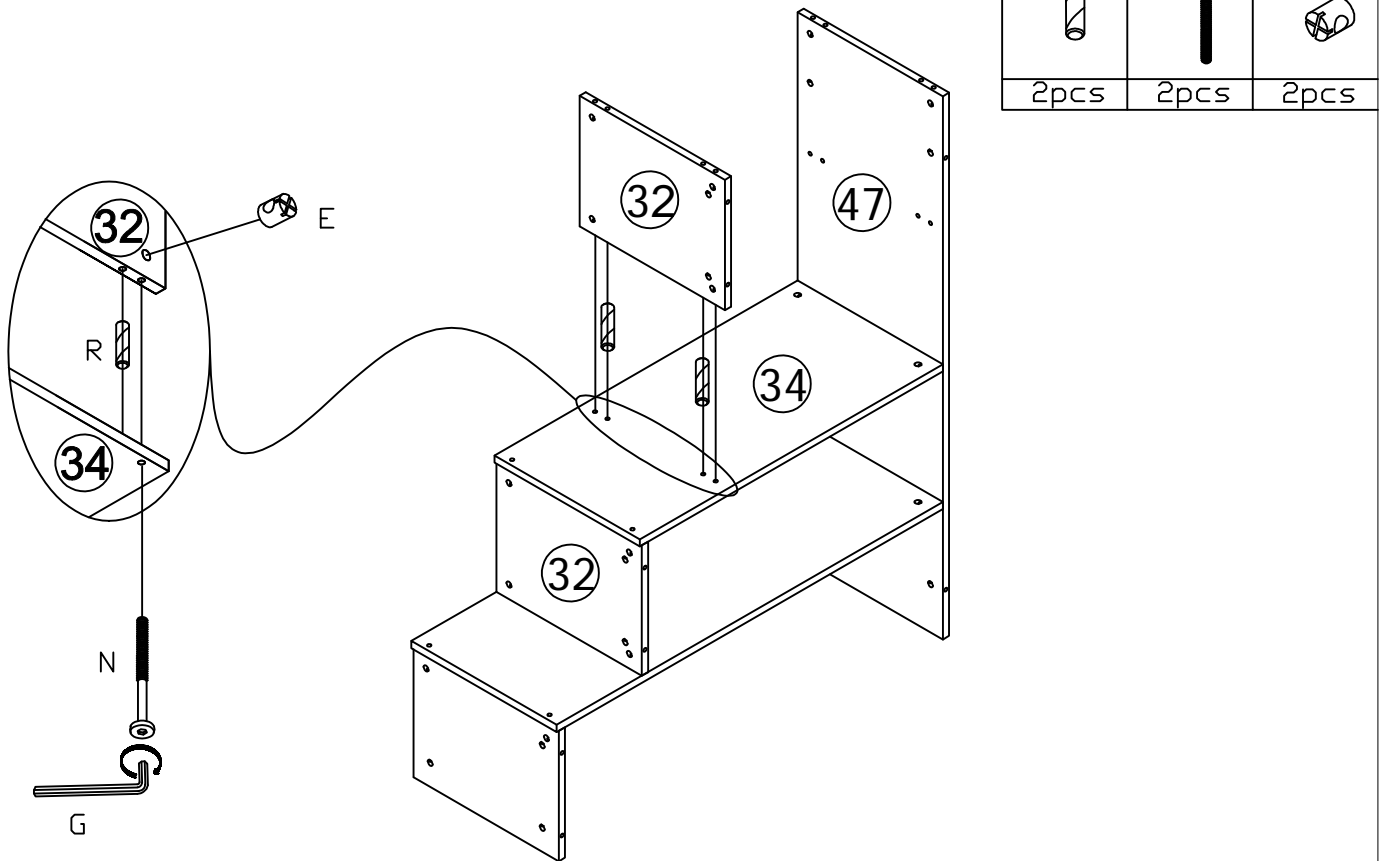

R	N	E
		
4pcs	4pcs	4pcs



Step 22

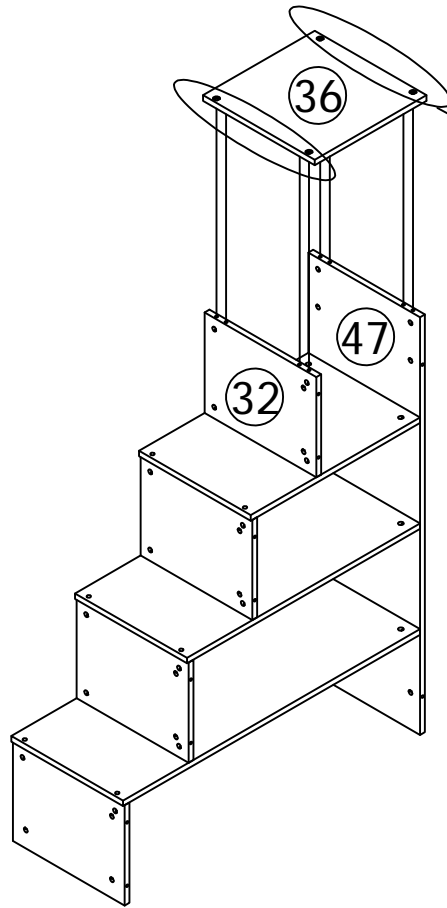

R	N	E
		
2pcs	2pcs	2pcs

Step 25



R	N	E
		
4pcs	4pcs	4pcs

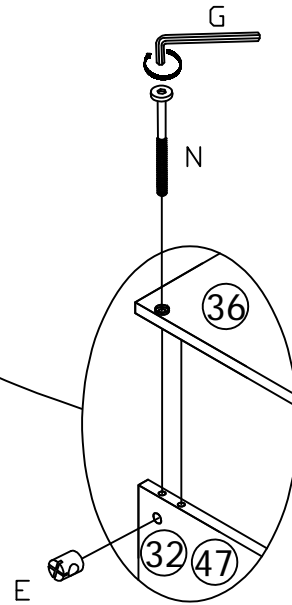

Step 26

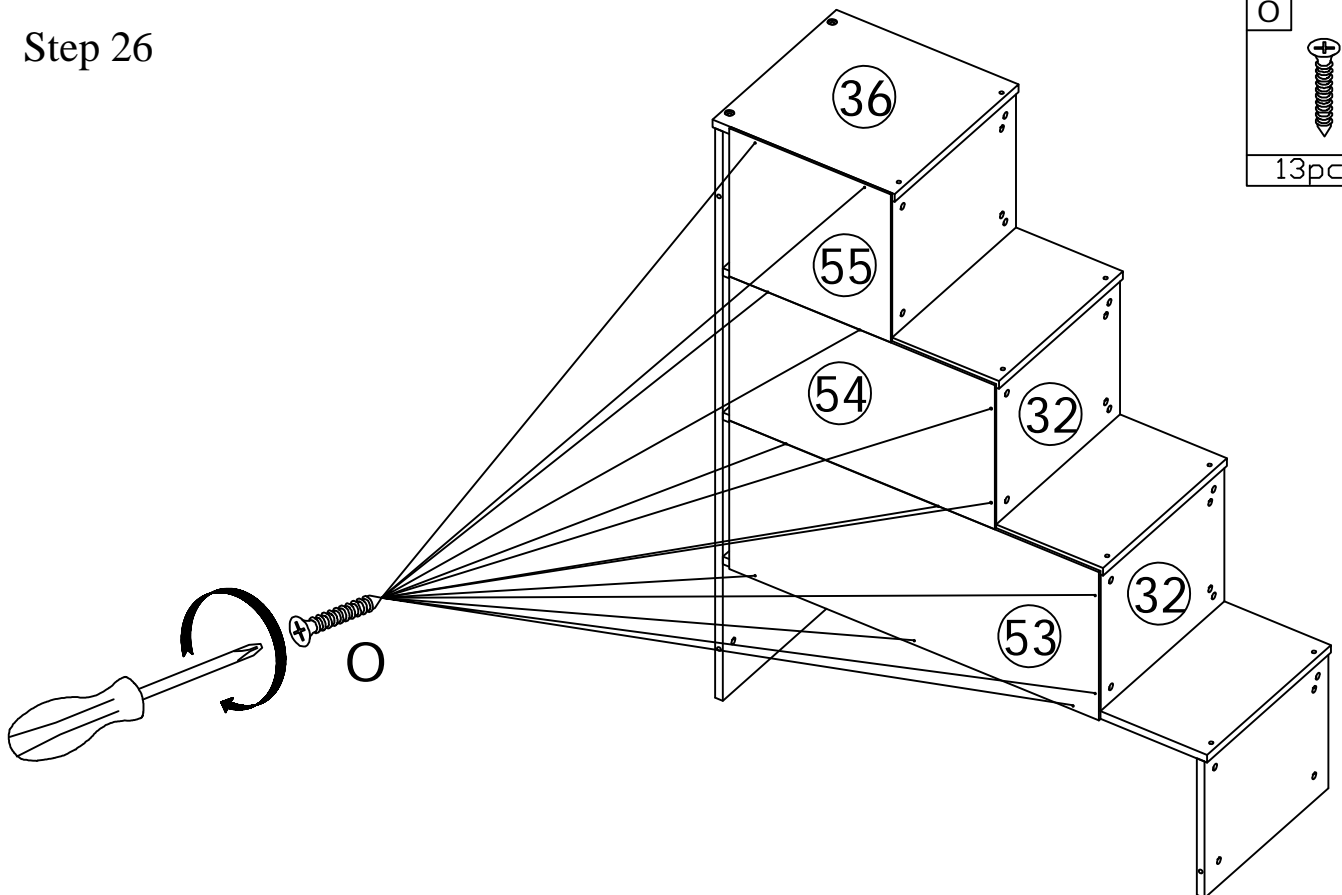

O

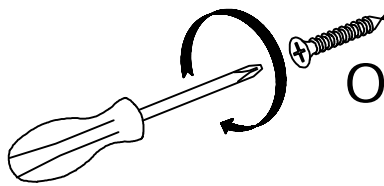
13pcs

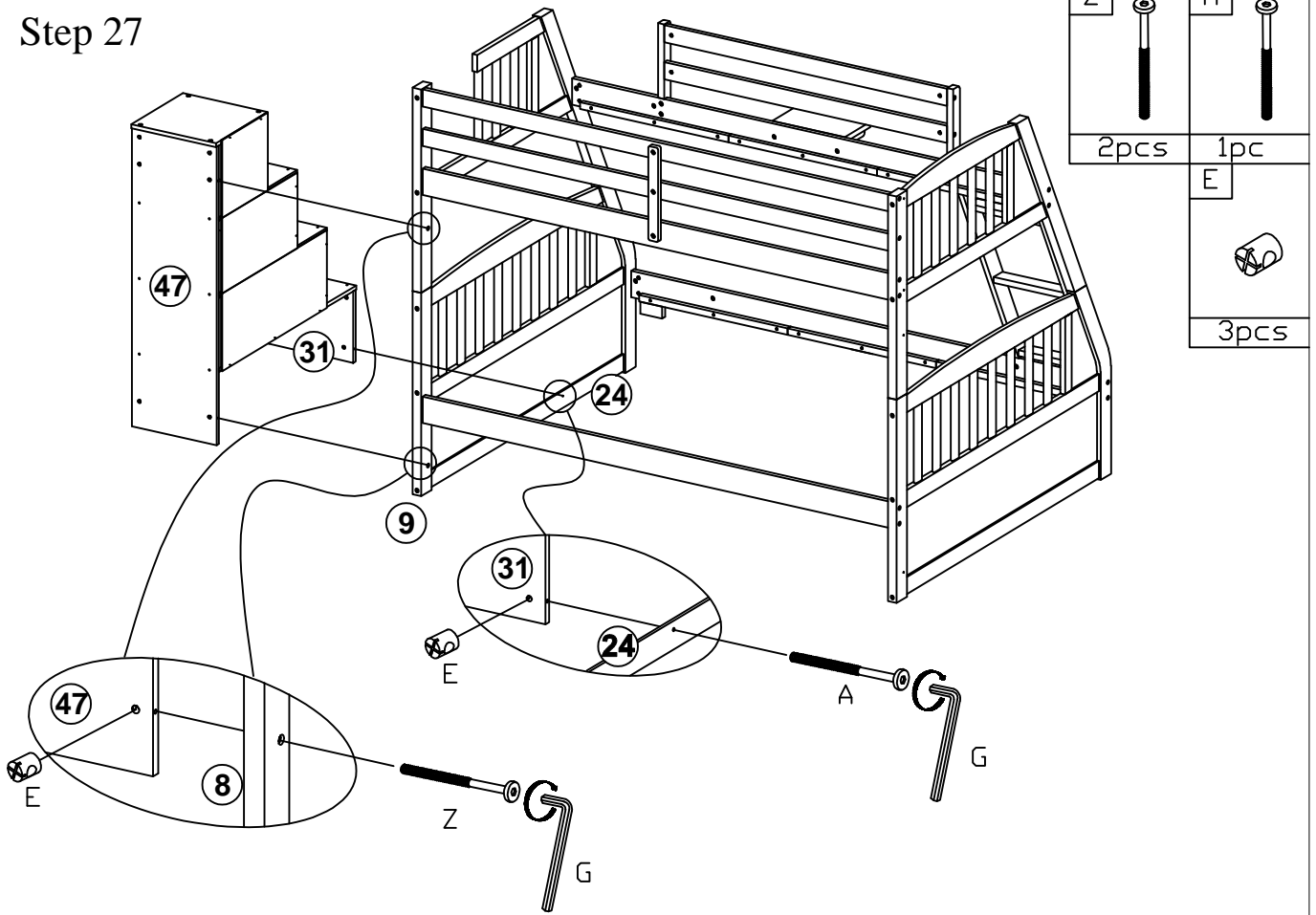

Step 27

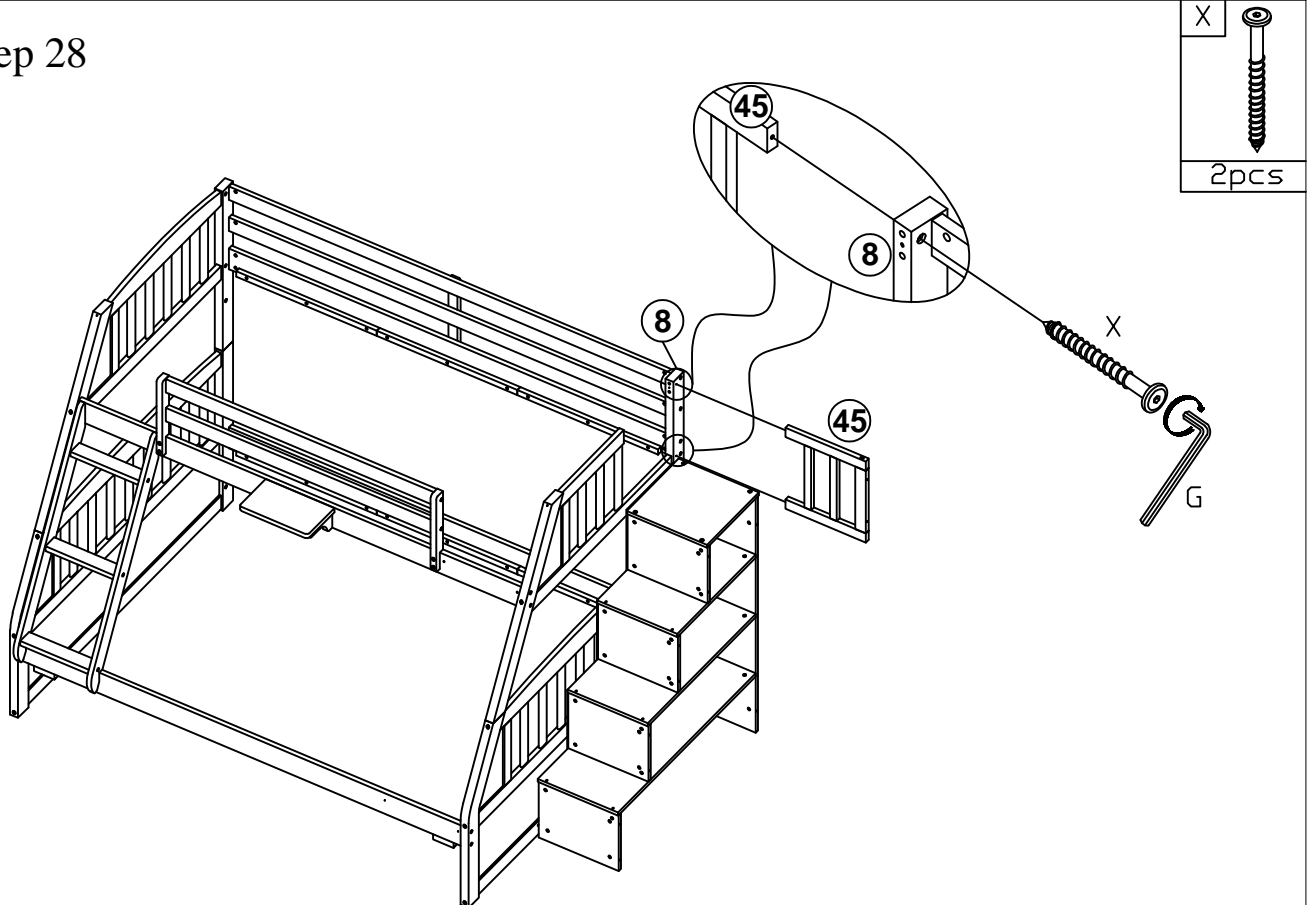

Step 28



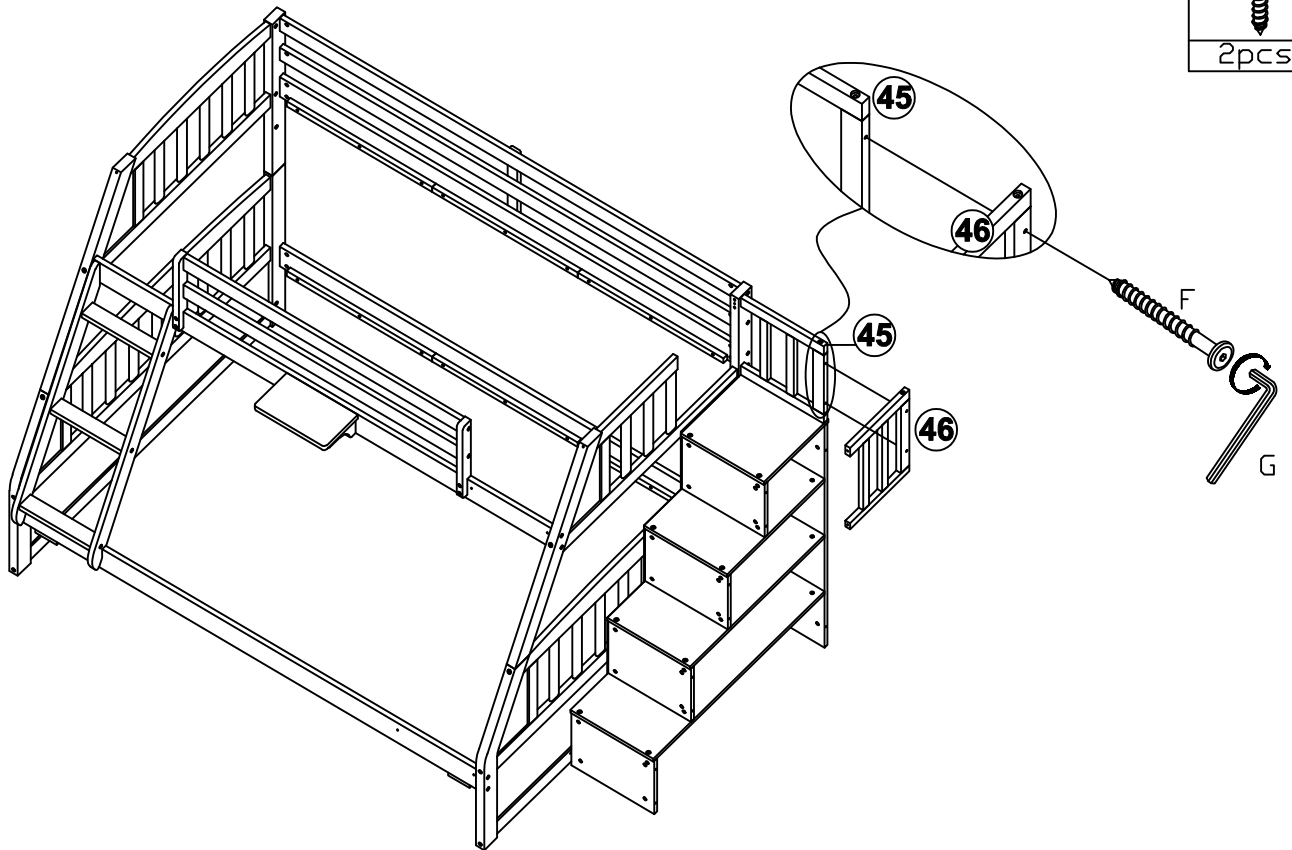

Step 29

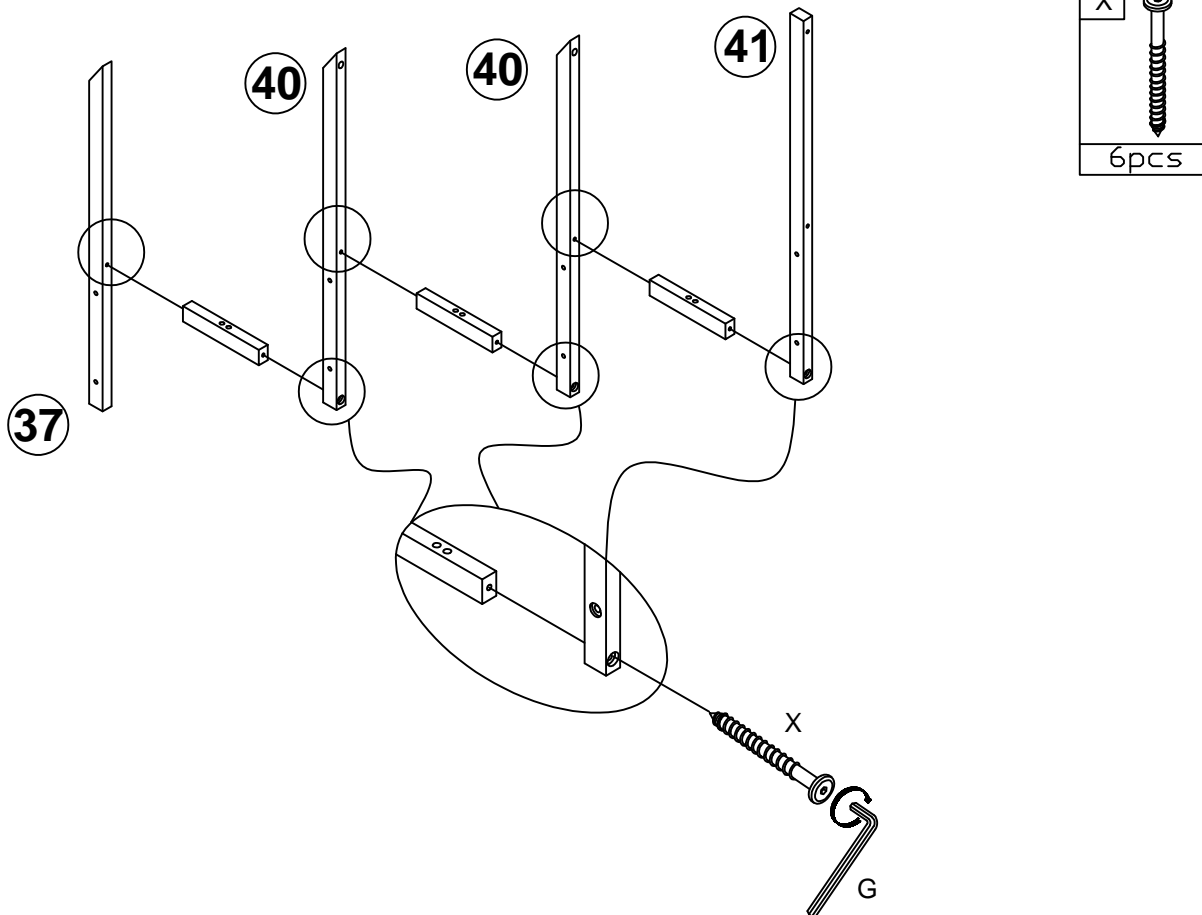

Step 30



Step 31

E	L
	
8pcs	8pcs

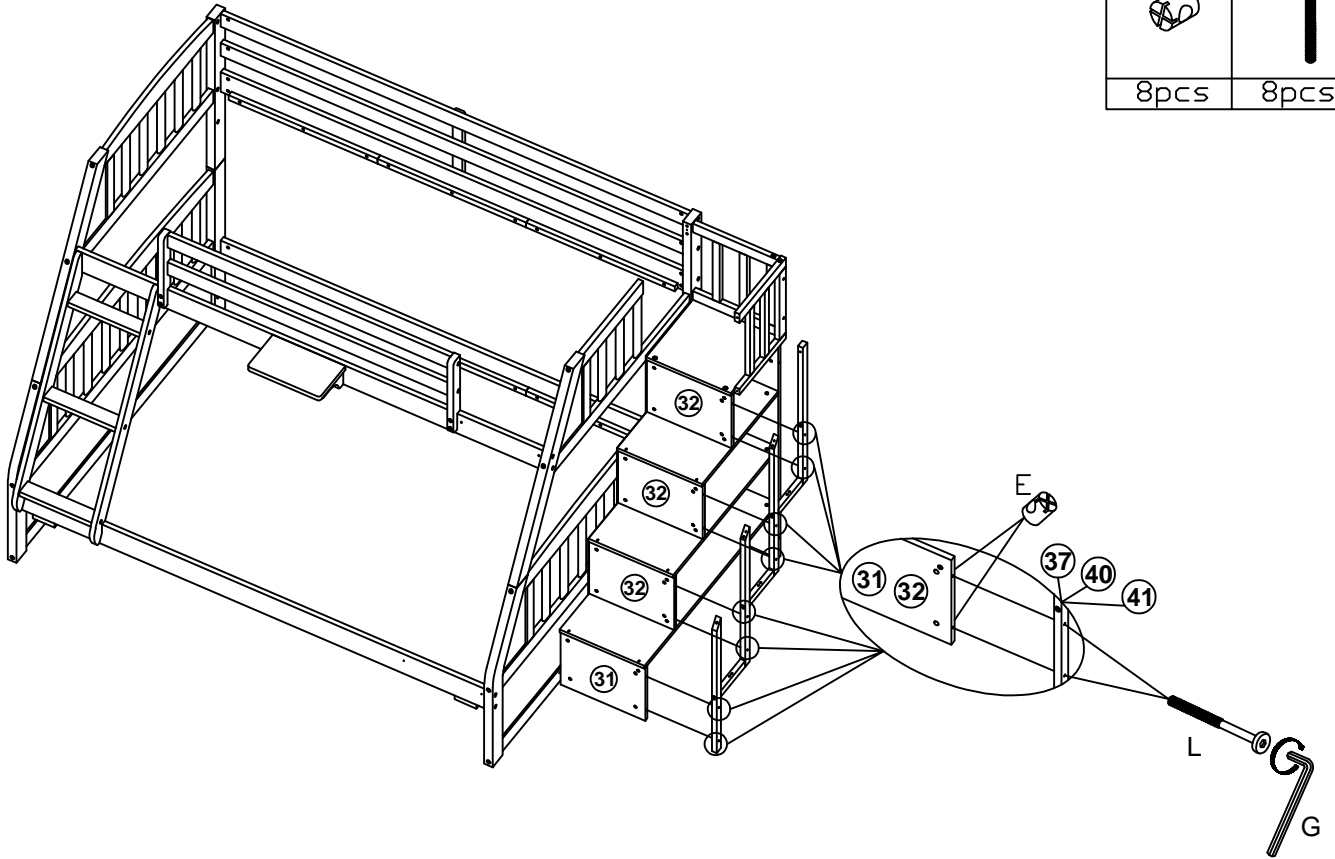

Step 32

X

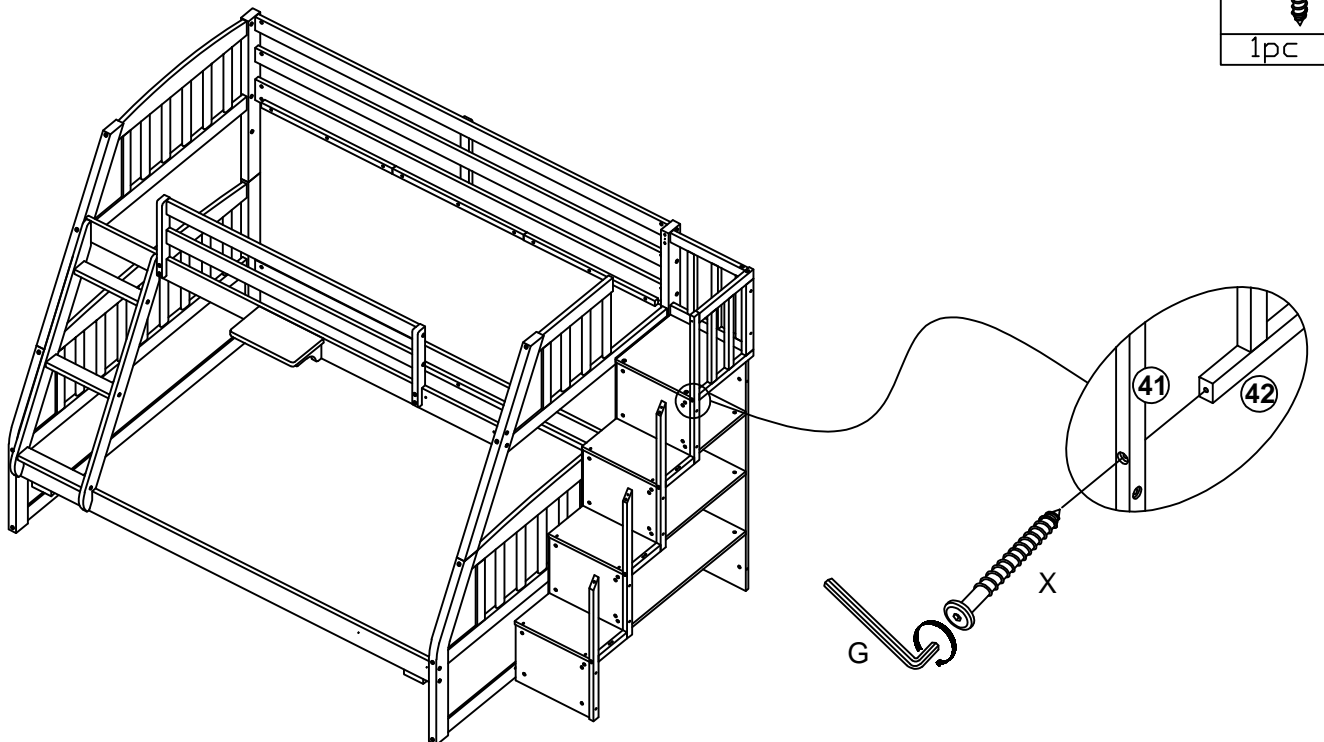
1pc





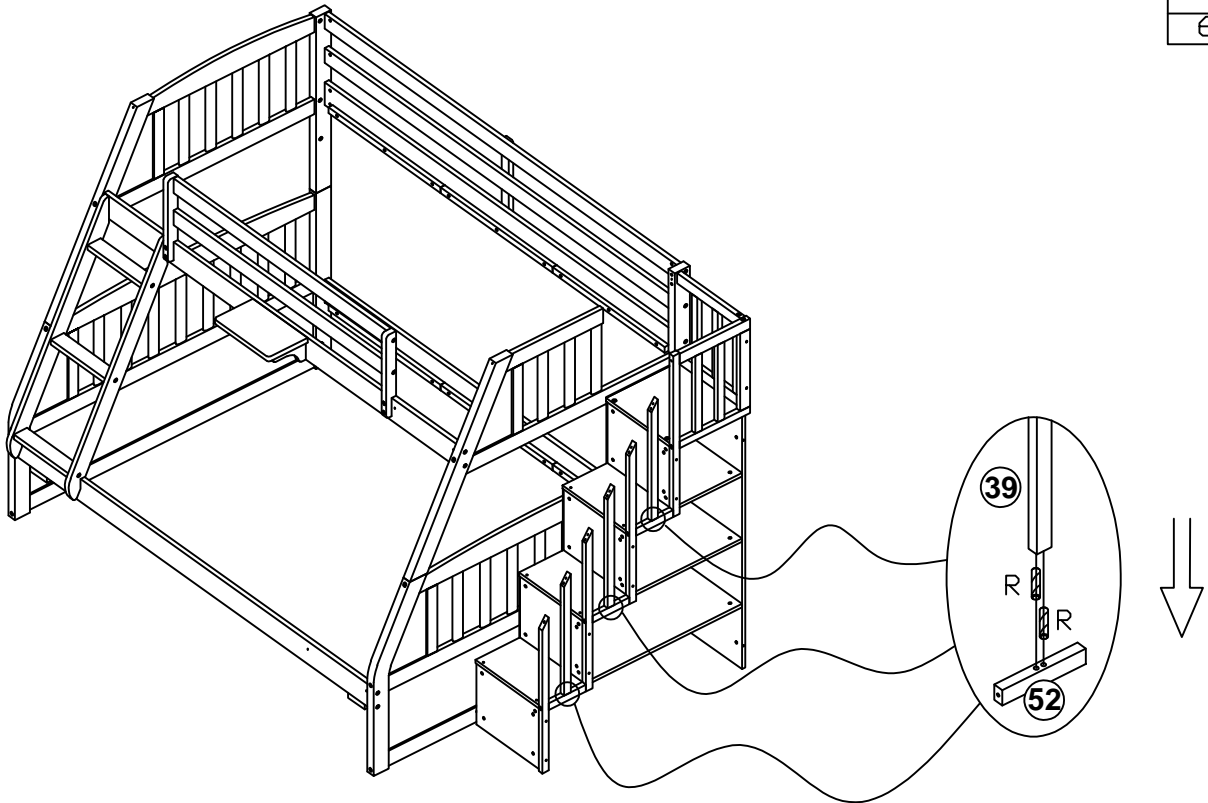

Step 33

R	
6pcs	



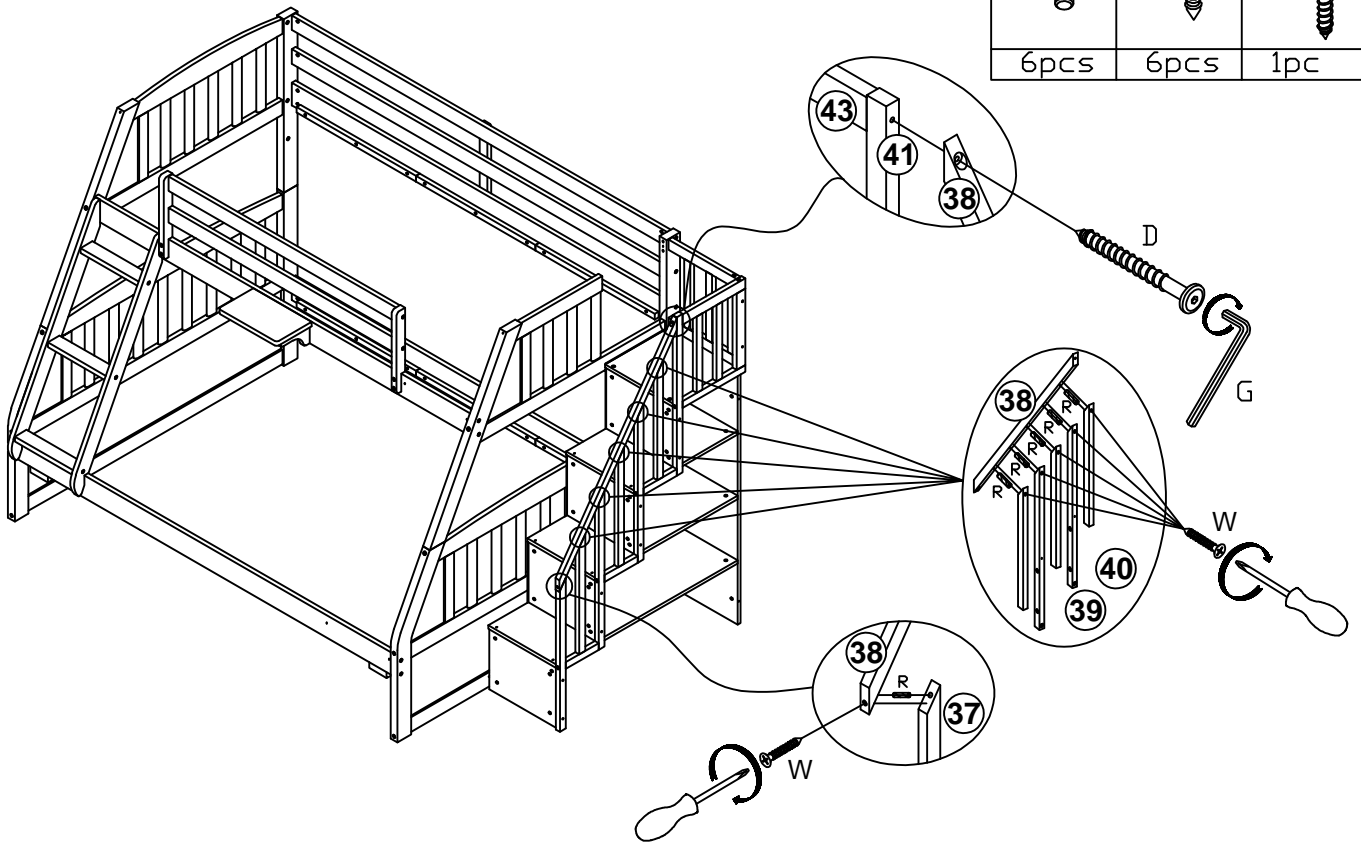

Step 34

R	W	D	
			
6pcs	6pcs	1pc	



Step 35

K	
	56pcs
P	
	4pcs

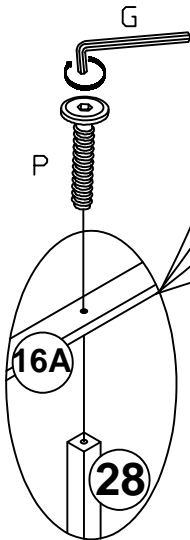
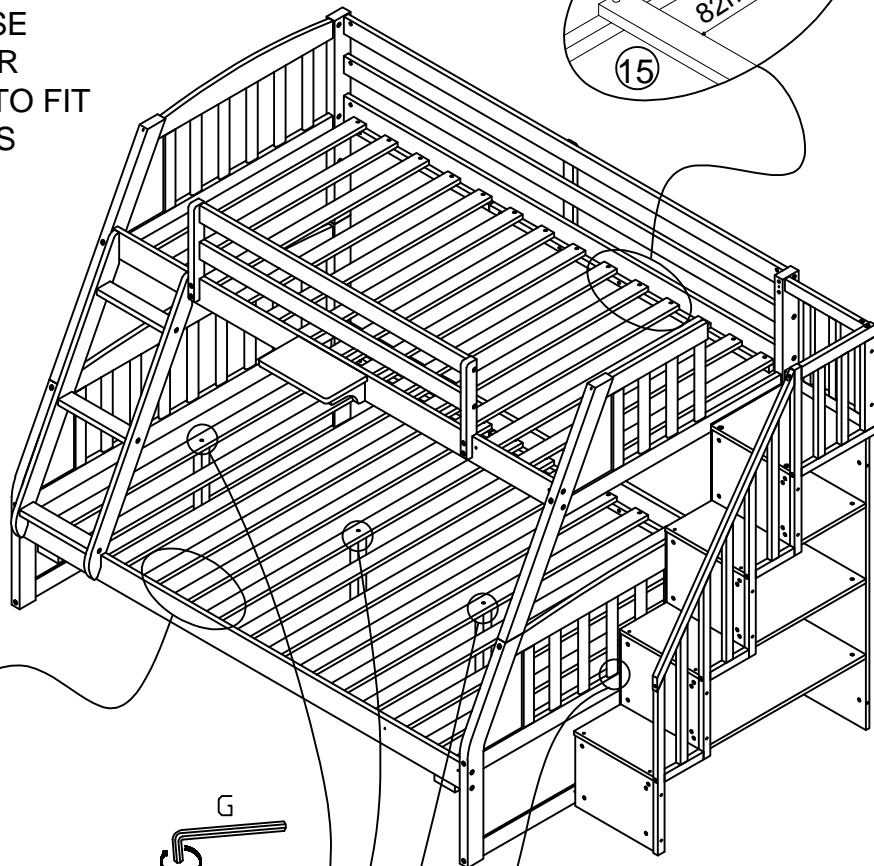
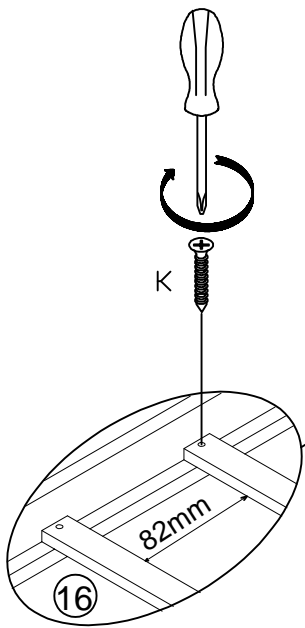
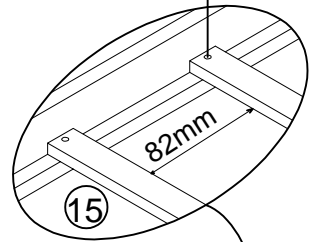
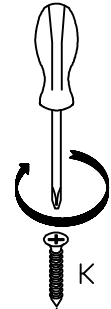

STEP 1: PULL SIDE RAIL CLOSE TOGETHER ENOUGH TO FIT THE SLATS

STEP 2: SCREW ALL SLATS





STEP 3: TIGHTEN 100% ALL HEXAGON BOLTS

Step 36

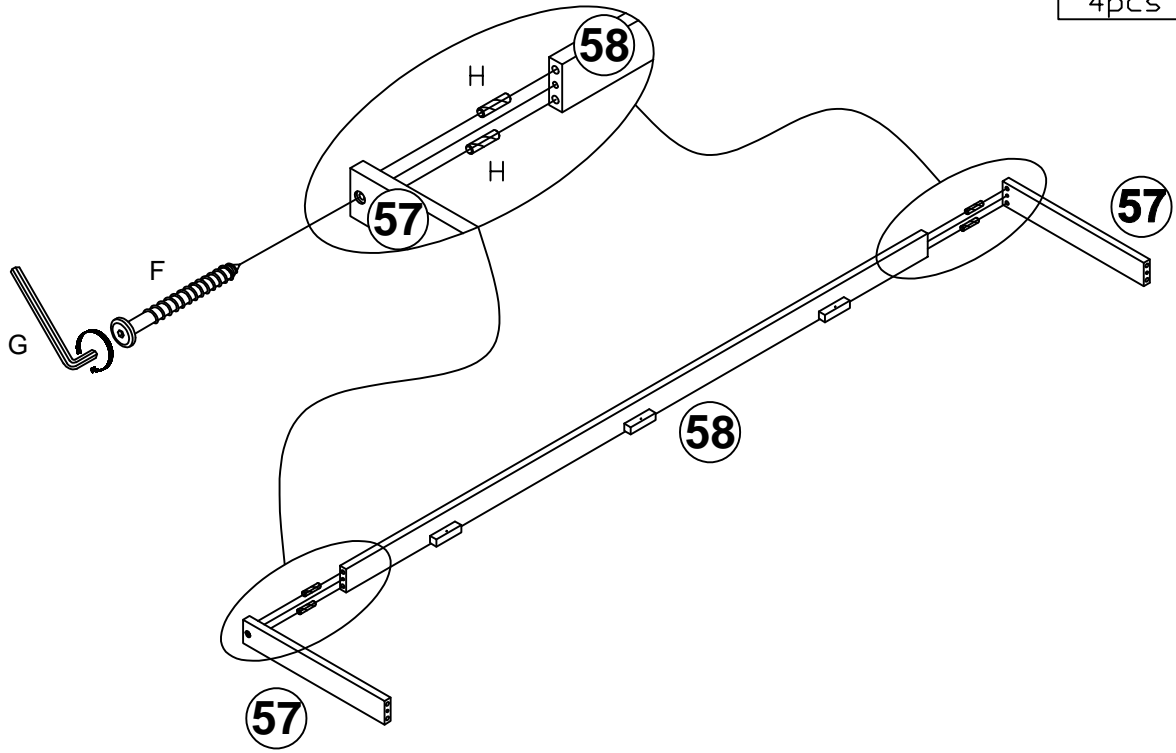
H	F
	
4pcs	2pcs



Step 37

H	F
	
4pcs	2pcs

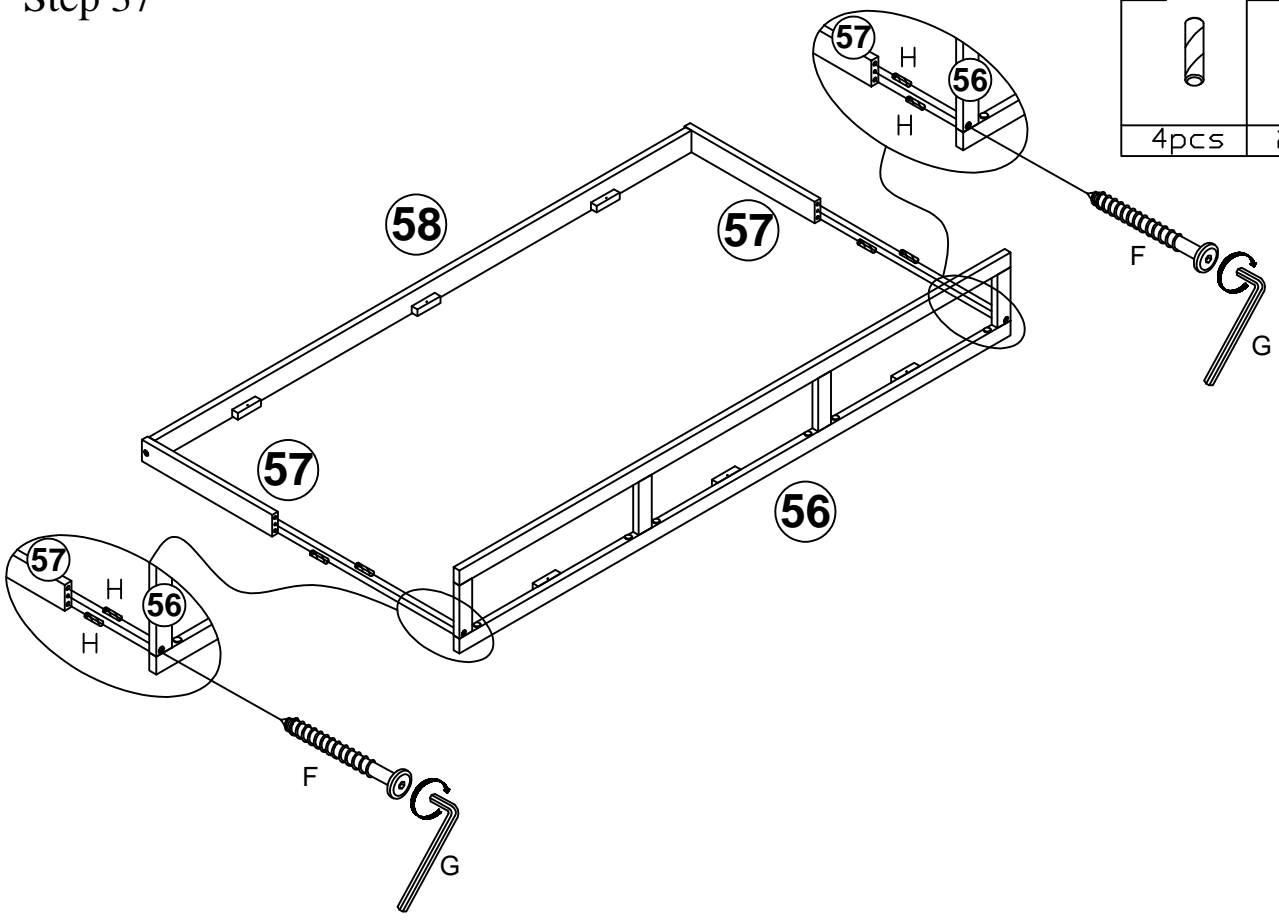

Step 38

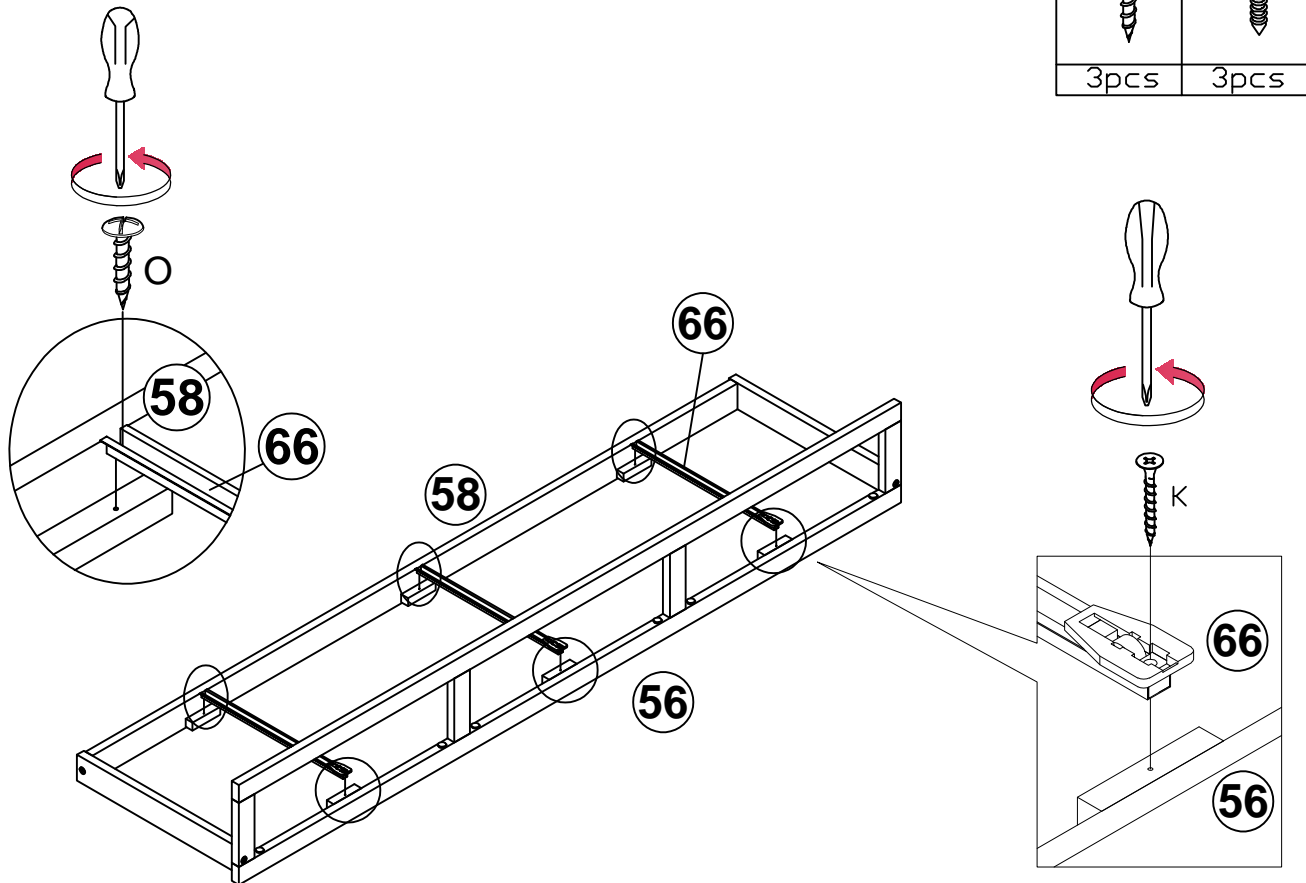

Step 39

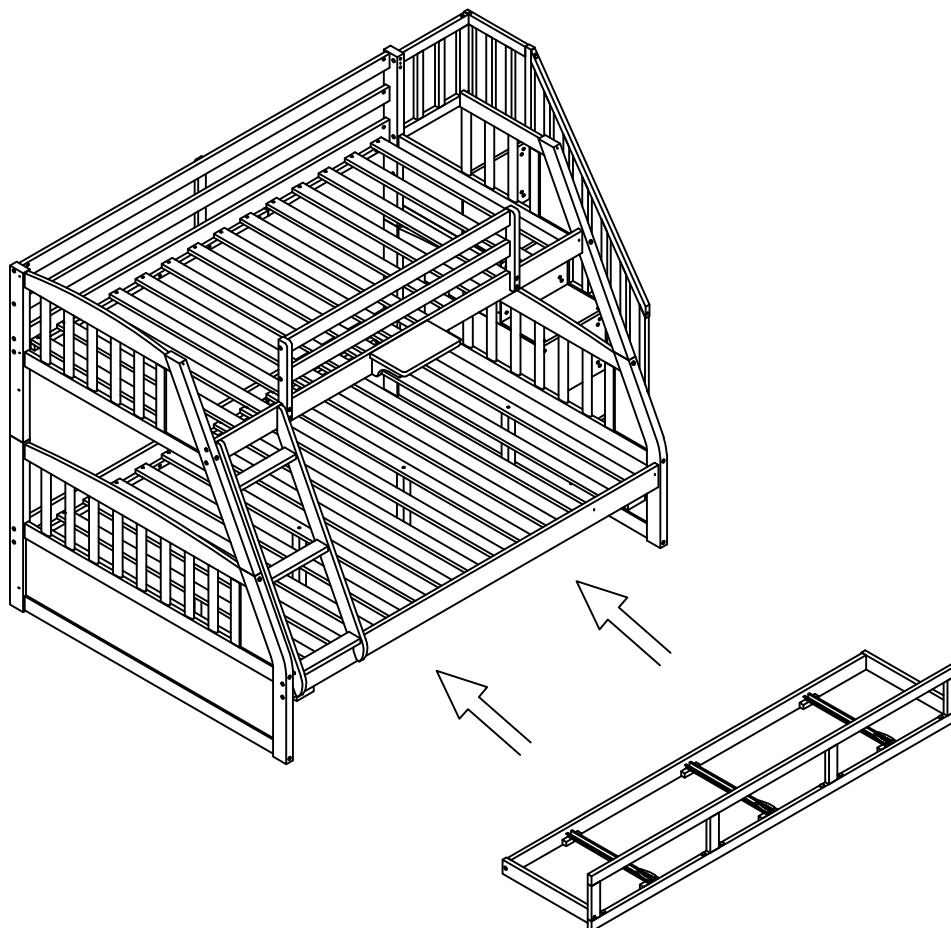

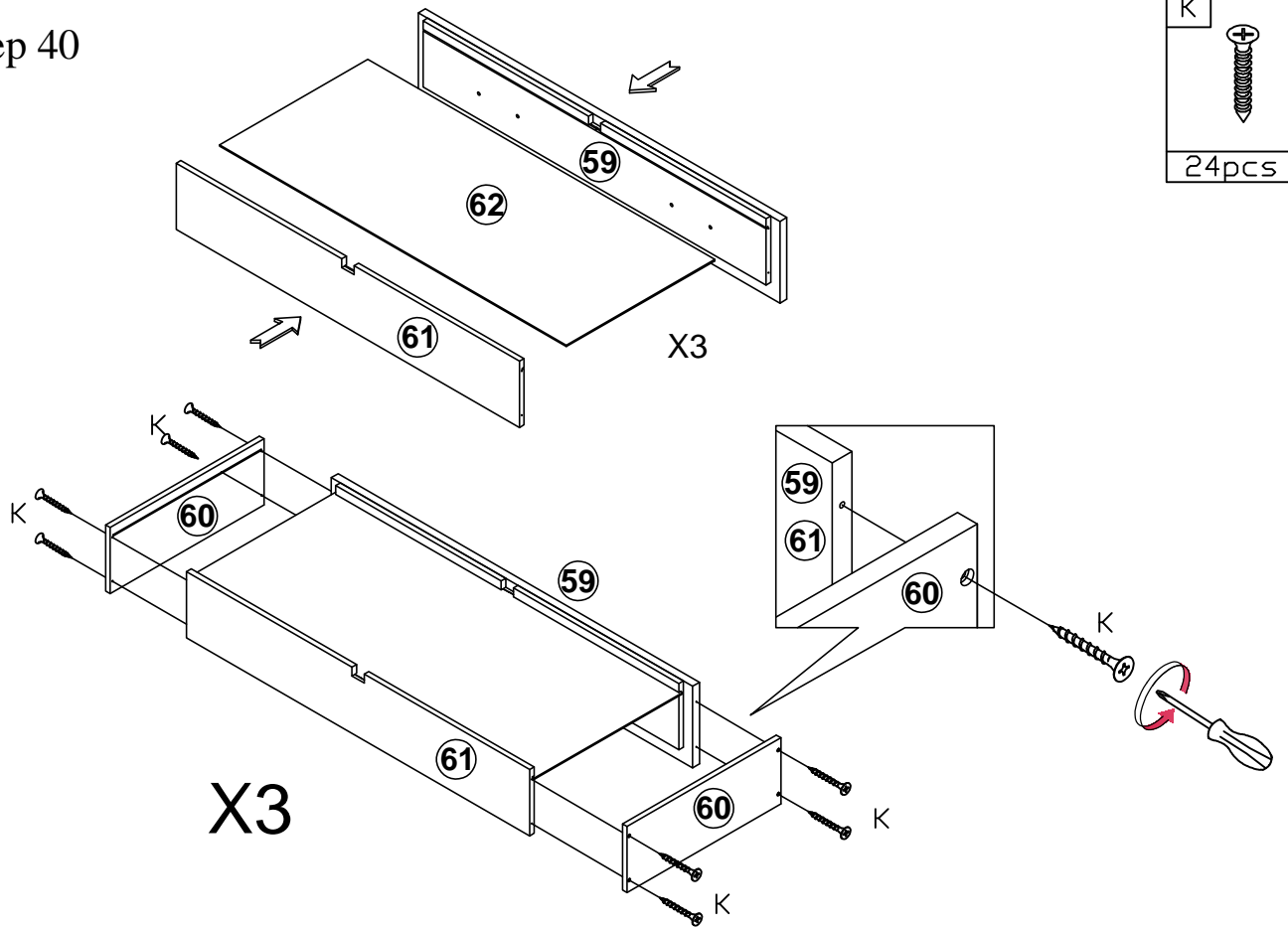

Step 40

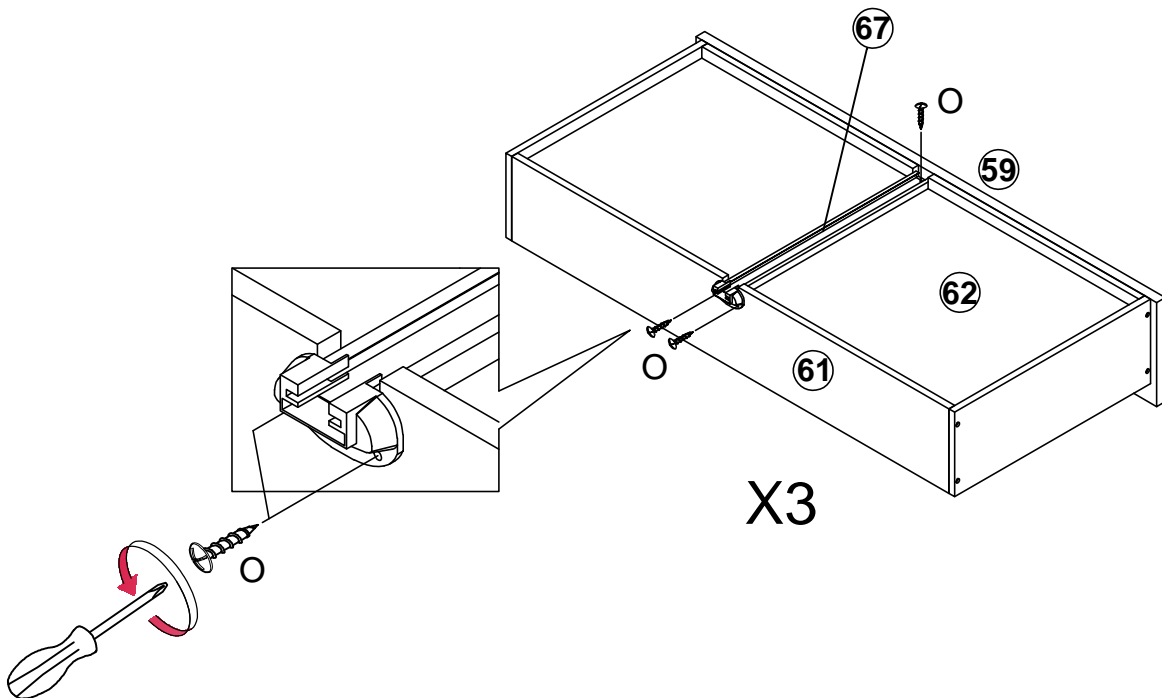

Step 41



Step 42

V	Y
	
3pcs	3pcs

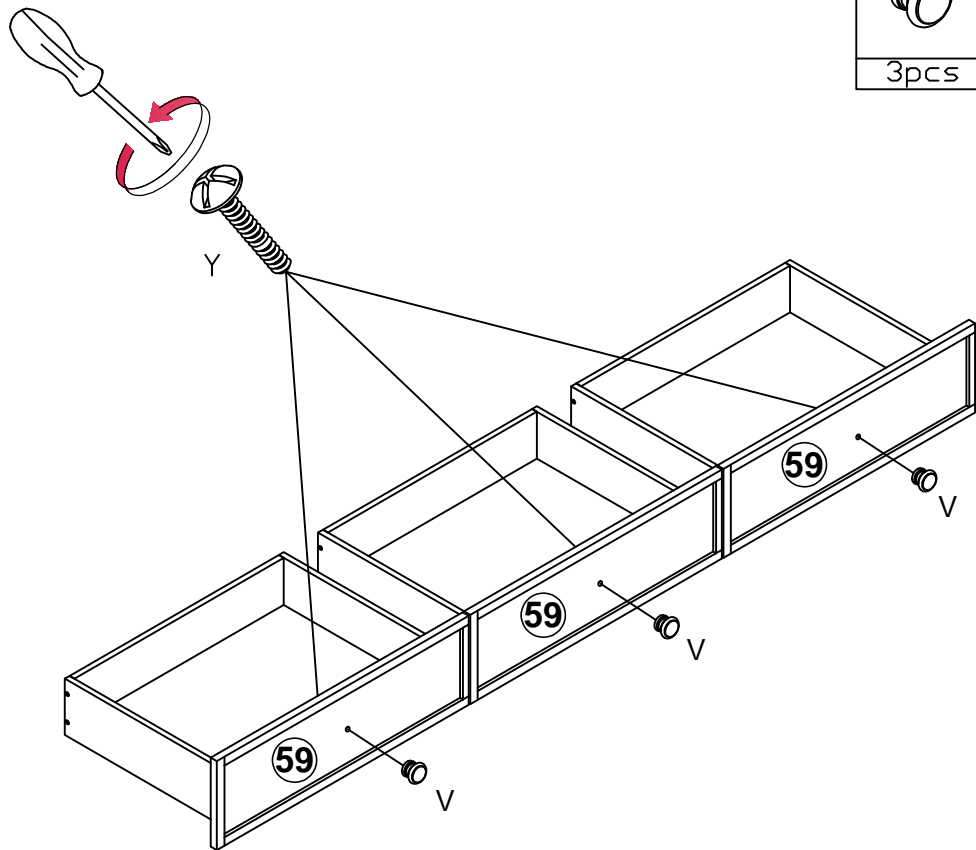

Step 43

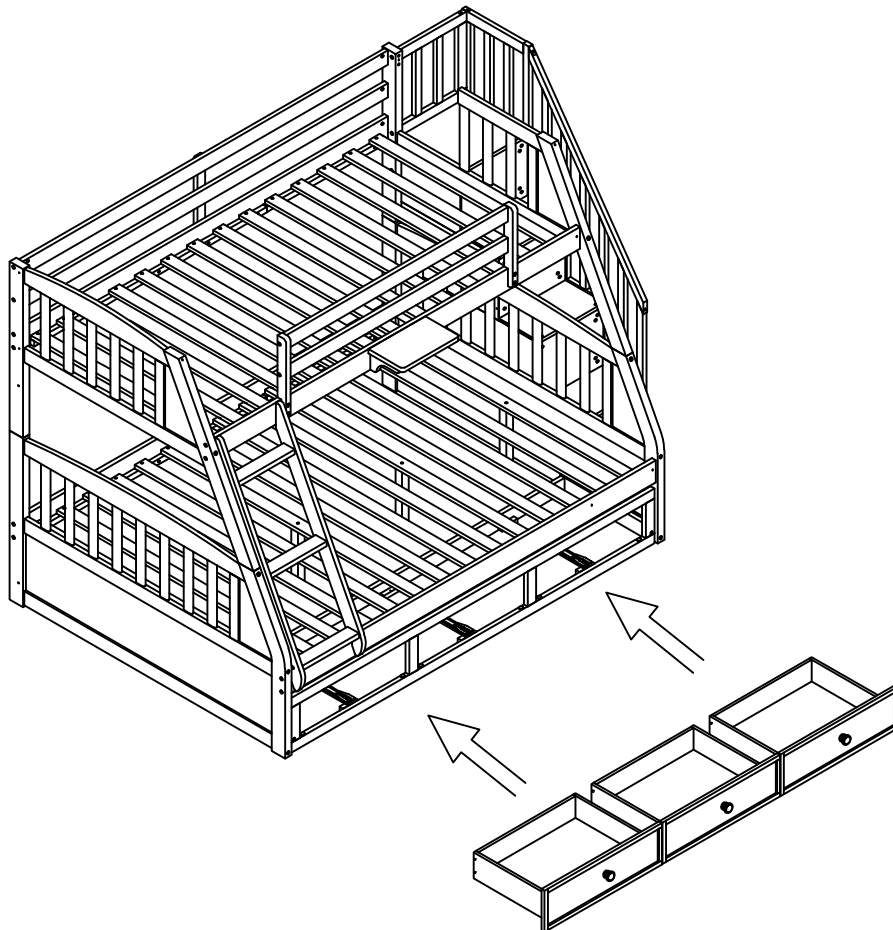

Step 44

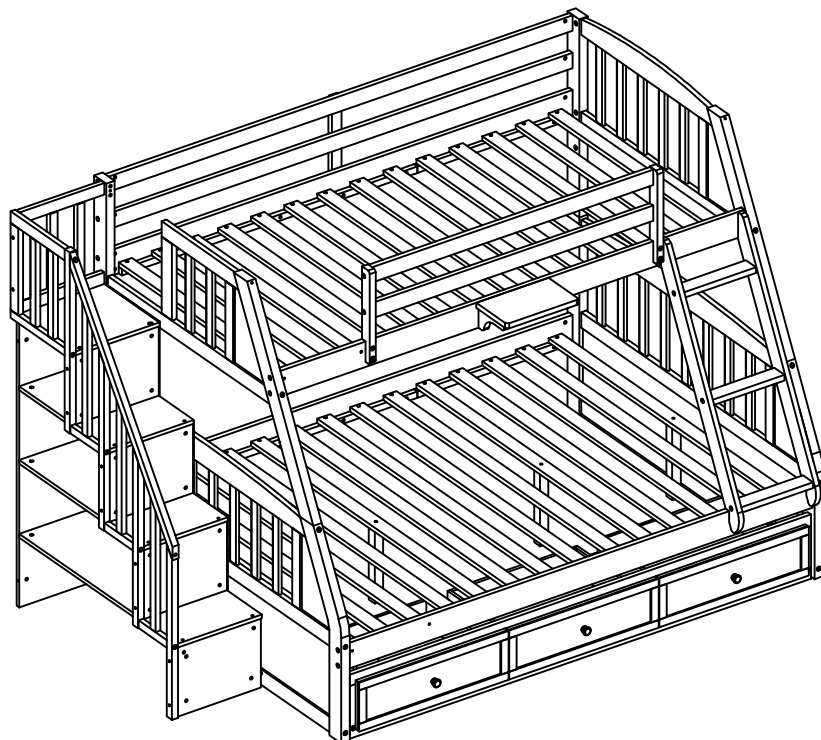
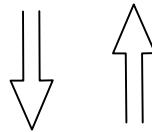
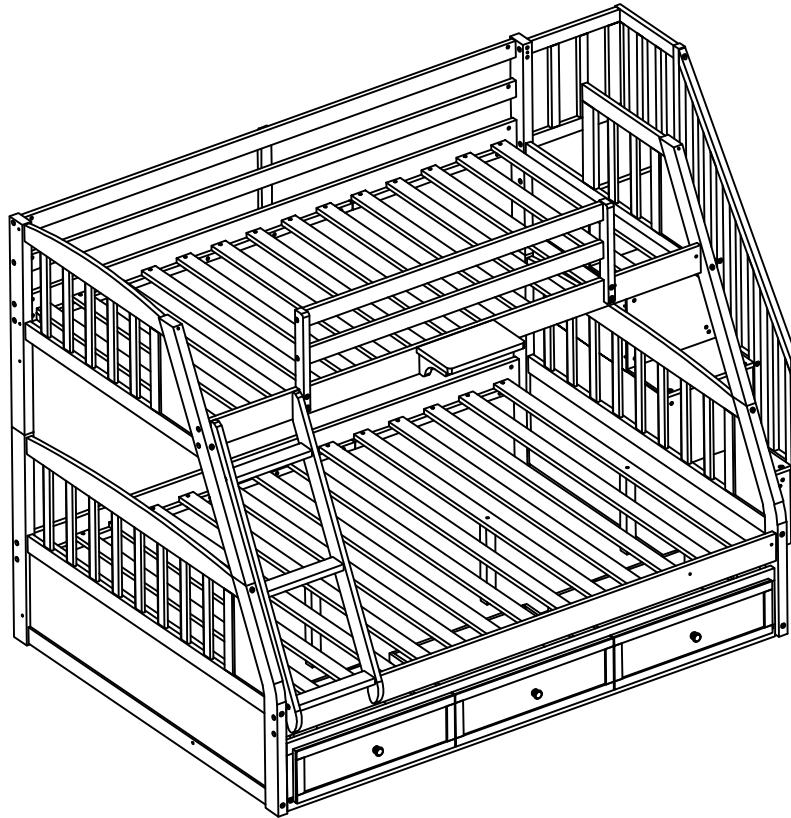

Note: Stairs and steps can be moved left or right.

COMPLETED

