



产品编号:PAC-2334SC-GR-XJ

INSTRUCTION MANUAL



FORM FOR REPLACING MISSING OR DAMAGED PIECES.

Please email to :customerservice@directwicker.com

Model # of product: _____
Store or website where product was purchased _____
Delivery date _____
Were the boxes are good when delivery to you Yes / No
Were the boxes delivered on the ground on the pallet Yes / No
Damages note on the Delivery receipt Yes / No

Name: _____

Address _____

Tel : _____

Please provide pictures of the installed furnitures and gazebos,of all six sides of the boxes,of all damaged places.











Part#	Qty	Description	Missing/Damaged
			M / D
			M / D
			M / D
			M / D

I attest that I have read the instructios and verified all the pieces were received.

Signature _____

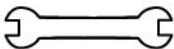
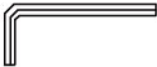
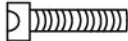
Date: _____

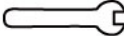
Assembly Instructions

A		part A	2 PCS
B		part B	1 PCS
C		part C	1 PCS
D		part D	1 PCS
E		1/4" ×30mm BOLT	10 PCS
F		Φ6.5×1.0mm WASHER	10 PCS
G		1/4" NUT	10 PCS
H		HEX WRENCH	1 PCS
I		HEX BOLT DRIVER M4/M5	2 PCS
J		M8×45	4 PCS
K		M8	4 PCS
L		M8	4 PCS
Y		HEX WRENCH	1 PCS
U		M8×45	4 PCS

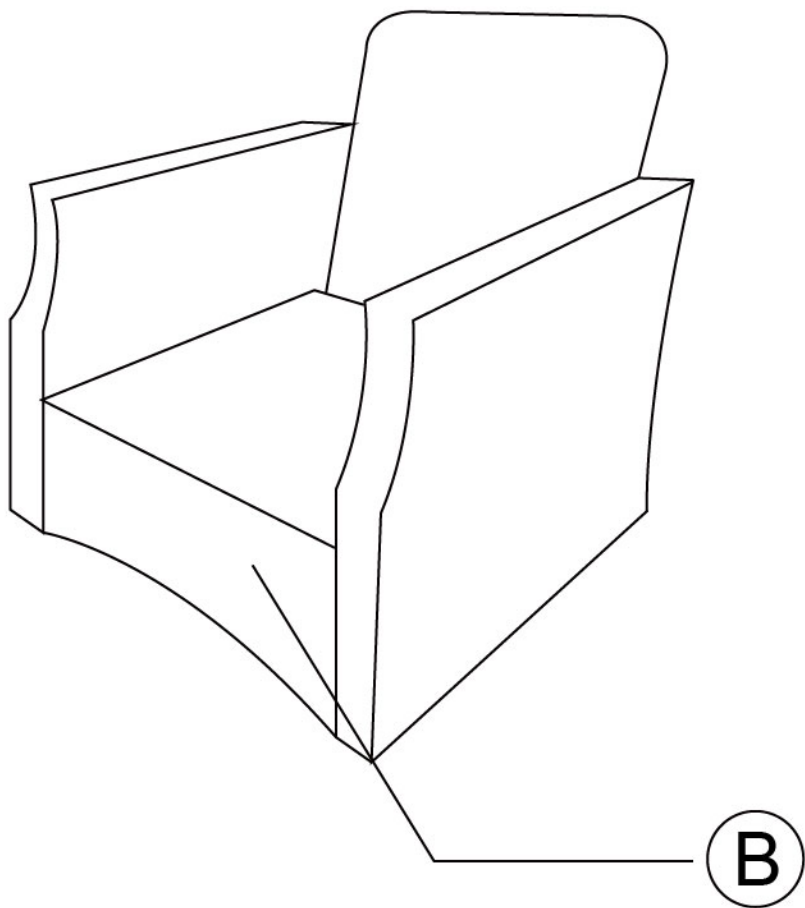

2

Assembly Instructions

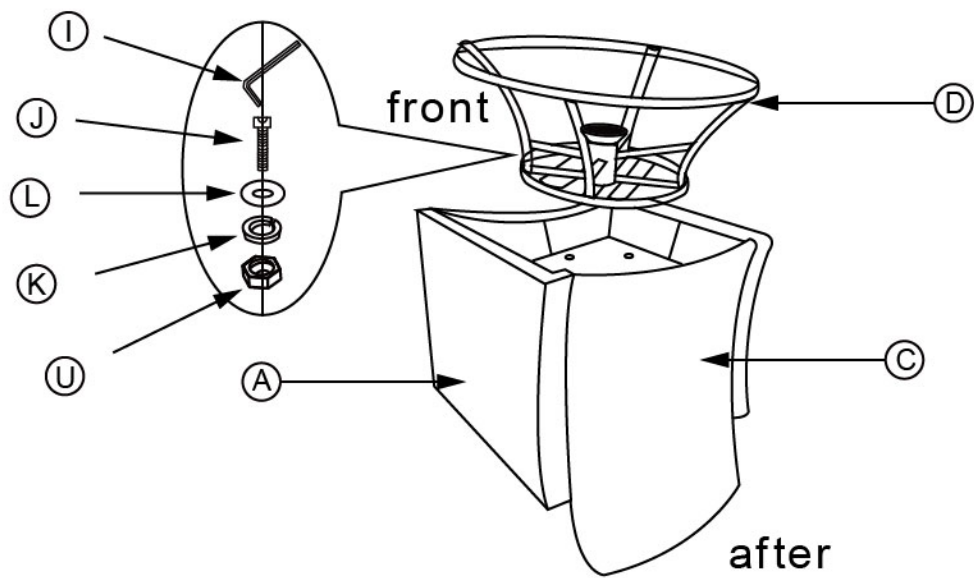

1

Assembly Instructions

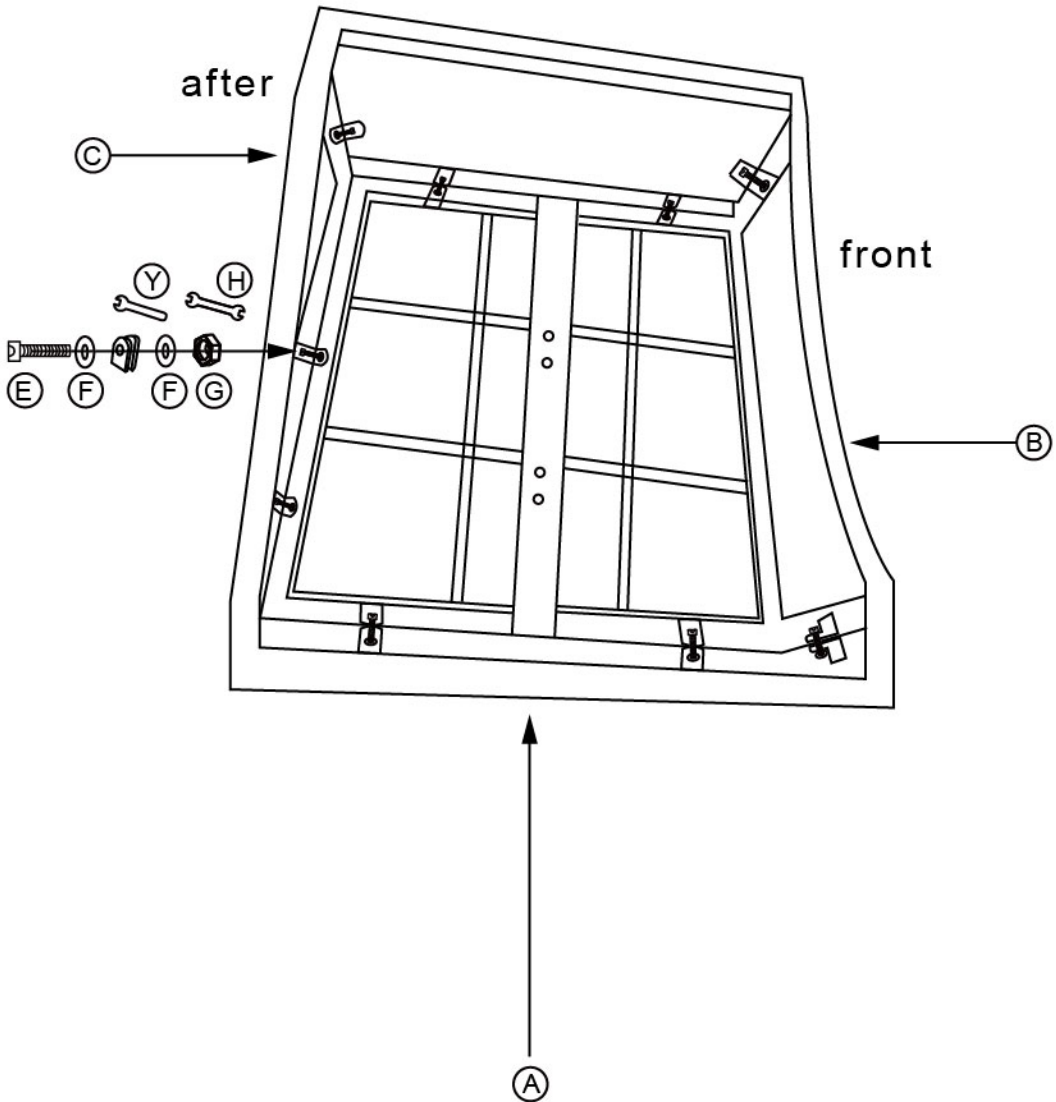



Customer Instruction Card

To our most beloved and valued customer:

Thank you for your order, and we appreciate your trust and support.

If you need any assistance or have any questions about your order, please reach our customer service team with your order number at:

Direct Wicker Corp Tel: (813) -304-1389

ET: 9 AM - 5 PM, Monday - Friday

If you would like to know more about Direct Wicker or need to forward documents, you can also reach us at: **customerservice@directwicker.com**

Our team will always be here to help.

Common Questions:

1. Normally the cushion is placed within the ottoman/ chair, please turn it upside down, you may find the cushion.
2. Please do not fully tighten the screws before all parts were assembled successfully, in case the products can not be lined up in position.
3. Furniture sets are mostly delivered in multiple cartons. If the numbers of boxes you received are not correct/missing. Please contact us via phone or email with your order number.
4. If you would like to return the order, be sure to also return any accessories and packing slips that came with your original package.
5. If the set is not in use for a long time, please cover it with a furniture cover or store it indoors.
6. Please be very careful with the glass, please do not handle the glass with bare hands if it was broken.

Thank you for your understanding and cooperation, we wish you a fantastic shopping experience with us, and we are looking forward to serving you again!

Direct Wicker Team

A stylized illustration of a hand holding a bouquet of flowers. The bouquet consists of several stems with small, colorful flowers in shades of pink, red, and light blue. The flowers are arranged in a circular pattern, and the hand is shown from the bottom right, holding the stems.

Your Home Our Passion



For more information, please visit our website:
www.directwicker.com