

PLASTIC GARDEN SHED 5x4FT

Instructions for Assembly



WARNING

Please read the instruction manual carefully before assembly.
Please assembly strictly in accordance with the instrution.
Please double-check to ensure that all parts of the package contents intact.
To avoid injury, work gloves are recommended during assembly.

SITE PREPARATION | PRÉPARATION DU SITE | PREPARACIÓN DEL LUGAR | VORBEREITUNG DES AUFSTELLUNGORTES | VOORBEREIDING VAN HET TERREIN | PREPARAZIONE DEL LUOGO DI ASSEMBLAGGIO | PREPARAÇÃO DO LOCAL

Level the ground surface | Nivelez la surface du sol | Nivele la superficie del suelo | Ebenen Sie die Bodenoberfläche | Maak de bodem vlak | Livellare la superficie del terreno | Nivele a superfície do solo

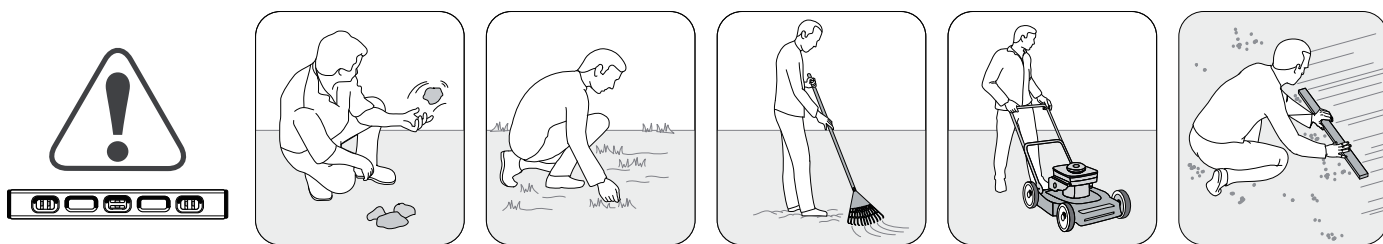

Recommendation: Construct a wooden or concrete base as a foundation | Recommandation: fabriquez une base en bois ou en béton en guise de fondation | Recomendación: construya una base de madera o de cemento a modo de cimiento | Empfehlung: Bauen Sie als Fundament eine Grundfläche aus Holz oder Beton | Aanbeveling: maak een houten of betonnen ondergrond als fundering | Raccomandazione: Costruire una base di legno o di cemento come fondamenta | Recomendação: Construa uma base de madeira ou de cimento como fundação

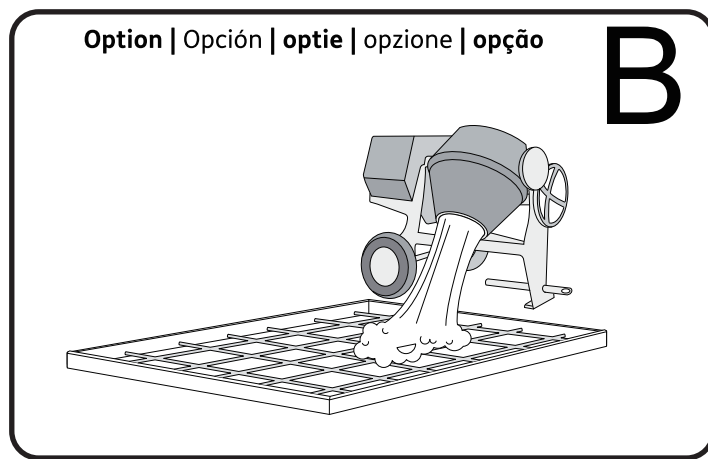
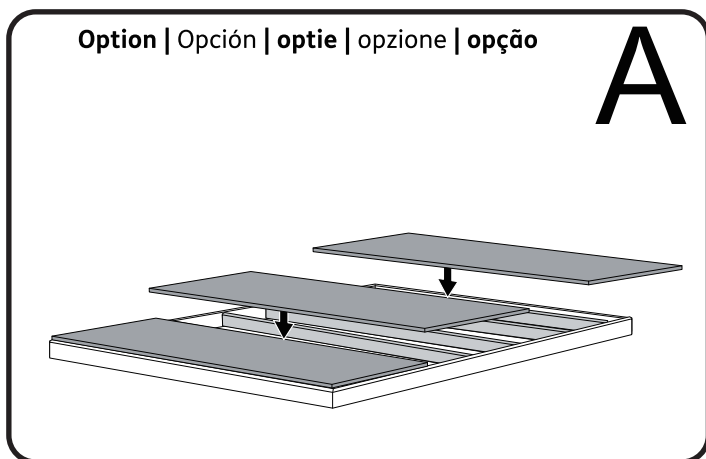

External floor measurements are: | Les mesures externes de la étage sont: | Las medidas del suelo externo son: | Die Außen-Bodenmaße betragen: | De afmetingen van de externe vloer zijn: | Le dimensioni esterne del pavimento sono: | As medidas externas do chão são:

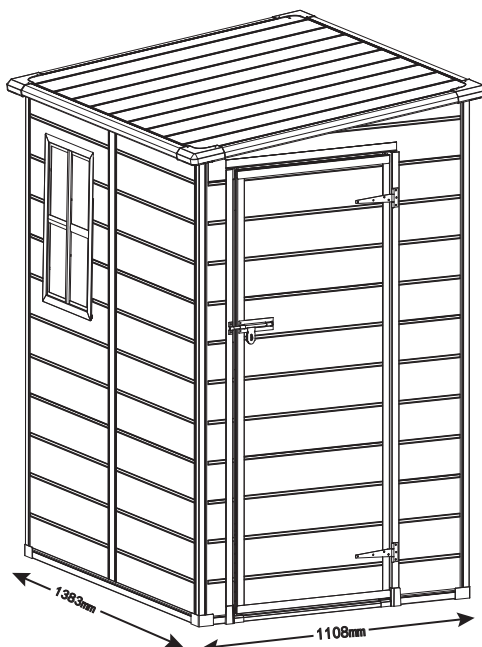

BEFORE STARTING ASSEMBLY | AVANT DE COMMENCER LE MONTAGE | ANTES DE EMPEZAR EL ARMADO | VOR MONTAGEBEGINN | VOORDAT U BEGINT TE MONTEREN | PRIMA DI INIZIARE L'ASSEMBLAGGIO | ANTES DE INICIAR A MONTAGEM

Read the care and safety guidelines at the end of this manual | Check to ensure that there are no missing or damaged parts BEFORE starting or arranging assembly | Remove all parts from the package(s) and spread them out on a clean work surface | Review all assembly instructions | Assemble all the parts according to the directions in this manual. Do not skip any steps.

Lisez les instructions de précaution et de sécurité à la fin de ce manuel | Assurez-vous qu'il n'y a pas de pièces manquantes ou endommagées AVANT de commencer ou d'organiser l'assemblage | Retirez toutes les pièces du/des paquet(s) et étalez-les sur une surface de travail propre | Lisez toutes les instructions de montage | Assemblez toutes les pièces selon les instructions de ce manuel. Ne sautez aucune étape.

Lea las instrucciones de precauciones y seguridad que están al final de este manual | Asegúrese de que no faltan piezas ni están dañadas ANTES de comenzar o disponer el montaje | Saque todas las piezas del paquete o paquetes y póngalas sobre una superficie de trabajo limpia | Revise todas las instrucciones de montaje | Monte todas las piezas según las instrucciones de este manual. No se saltee ningún paso.

Lesen Sie die Sicherheitsrichtlinien am Ende des Benutzerhandbuchs durch | Prüfen Sie bitte VOR dem Zusammenbau, dass keine Teile beschädigt sind oder fehlen | Nehmen Sie alle Teile aus der Verpackung und breiten Sie sie auf einer sauberen Arbeitsfläche aus | Gehen Sie noch einmal die komplette Aufbauanleitung durch | Bauen Sie alle Teile entsprechend der Anleitung in diesem Handbuch zusammen. Lassen Sie dabei keinen Arbeitsschritt aus.

Lees de richtlijnen voor zorg en veiligheid achterin deze handleiding | Controleer dat er geen onderdelen mankeren, of beschadigd zijn, VOORDAT u met de montage begint | Haal alle onderdelen uit het pakket (of uit de pakketten) en leg ze opeen schoon werkoppervlak | Bekijk alle montagehandleidingen | Monteer alle onderdelen volgens de aanwijzingen van deze handleiding. Sla geen stappen over.

Leggere le linee guida di assistenza e sicurezza alla fine di questo manuale | Assicurarsi che non ci siano parti mancanti o danneggiate PRIMA di iniziare l'assemblaggio | Estrarre tutti i componenti dall'imballo e posizzarli su una superficie di lavoro pulita | Consultare tutte le istruzioni di montaggio | Assemblare tutti i componenti secondo le istruzioni contenute nel manuale. Non saltare nessuna fase.

Leia as diretrizes de cuidados e segurança que constam da parte final deste manual | Verifique para se assegurar de que não há peças em falta ou danificadas ANTES de começar a preparar a montagem | Retire todas as peças da embalagem e espalhe-as numa superfície de trabalho limpa | Reveja todas as instruções de montagem | Monte todas as peças de acordo com as instruções do manual. Não salte quaisquer passos.

REQUIRED TOOLS | OUTILS EXIGÉS | HERRAMIENTAS NECESARIAS | BENÖTIGTE WERKZEUGE | BENODIGD GEREEDSCHAP | ATTREZZATURA OCCORRENTE | FERRAMENTAS NECESSÁRIAS

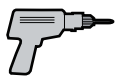

SPATULA | SPATULE | ESPÁTULA | SPACHTEL | SPATEL | SPATOLA | ESPÁTULA

- Use spatula (part “**SG8**”) for easier insertion of panel into profile.
- Utilisez la spatule (partie “**SG8**”) pour une meilleure insertion du panneau dans le profil.
- Utilice una espátula (pieza “**SG8**”) para una mejor inserción del panel en el perfil.
- Benutzen Sie den Spachtel (Bezeichnung “**SG8**”), um die Platten leichter in die Nut einführen zu können.
- Gebruik spatel (onderdeel **SG8**) voor het gemakkelijk invoeren van het paneel in het profiel.
- Utilizzare la spatola (parte **SG8**) per inserire il pannello più facilmente nel profilo.
- Utilize uma espátula (peça “**SG8**”) para facilitar a inserção do painel no perfil.

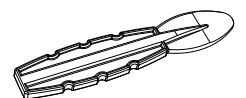































































SG8 x2



ASSEMBLY REQUIRES TWO PEOPLE | LE MONTAGE DOIT ÊTRE EFFECTUÉ PAR DEUX PERSONNES | SE NECESITAN DOS PERSONAS PARA ARMARLO | ZWEI PERSONEN ZUR MONTAGE NOTWENDIG | MONTAGE VEREIST TWEE PERSONEN | L'ASSEMBLAGGIO RICHIEDE DUE PERSONE | A MONTAGEM EXIGE DUAS PESSOAS

PARTS LIST

NO.	PART.	Qty.
BW1-1		9
BW1-2		1
BW1-3		1
BW1-4		1
BW1-5		2
BW2-1		1
BW3-1		2
BW3-2		1
BW4-1		2
BW4-2		1
BW5-1		2
BD1-1		1
BD1-2		1
BD1-3		1
BR2-1		1
BR2-2		1
BF2-1		1
BF2-2		1
BW5-2		1
BW6-1		1
BP1		1
BP2		2
BP3		2
BP4		2
BP5		1
BP10		2
BP7		2
BA3		1
BA1R		1
SG12		2
BR2-3		1

NO.	PART.	Qty.
BA1L		1
BA2R		1
BA2L		1
AA4		1
AS1		1
BPA1		1
BPA2		1
SG102		2
SG103		2
BP8		1
BP9		1
SG10		1
SG101		1
M01		2
M03-6L		1
M03-7		1
M04		1
SG2		4
SG6		4
SG7-2		1
SG7-1		1
SG8		2
SG9		3
Drill		1
Z410		76
Z420		109
ZW413		22
SG14		2
SG15		2
BS1		1
BF2-3		1

- Use spatula  (part "SG8") for easier insertion of panel into profile
- Please ensure the panels are all installed on position before screwing



FLOOR ASSEMBLY

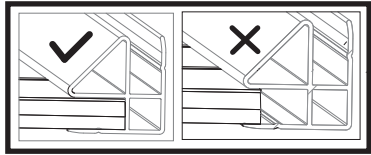

● Fully fit the panel inside the profile

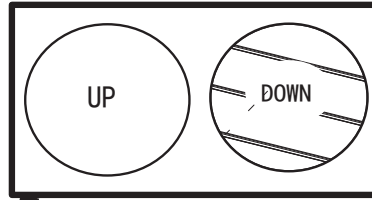

● Note: The crease line of the floor must be underneath

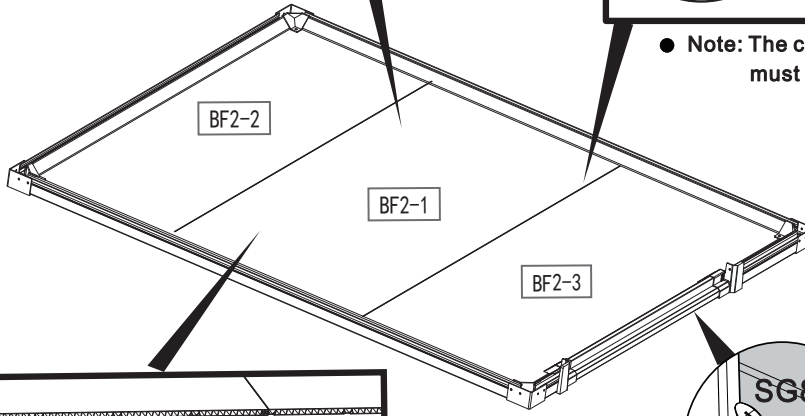

● The floor panels must be straight

● Use spatula (part "SG8") for easier insertion of panel into profile

Step 1

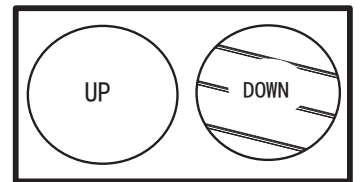
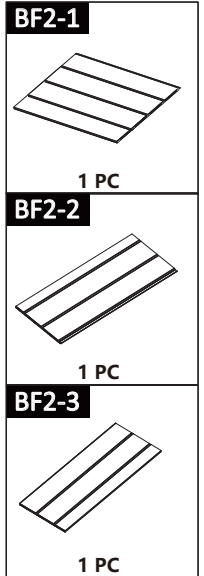
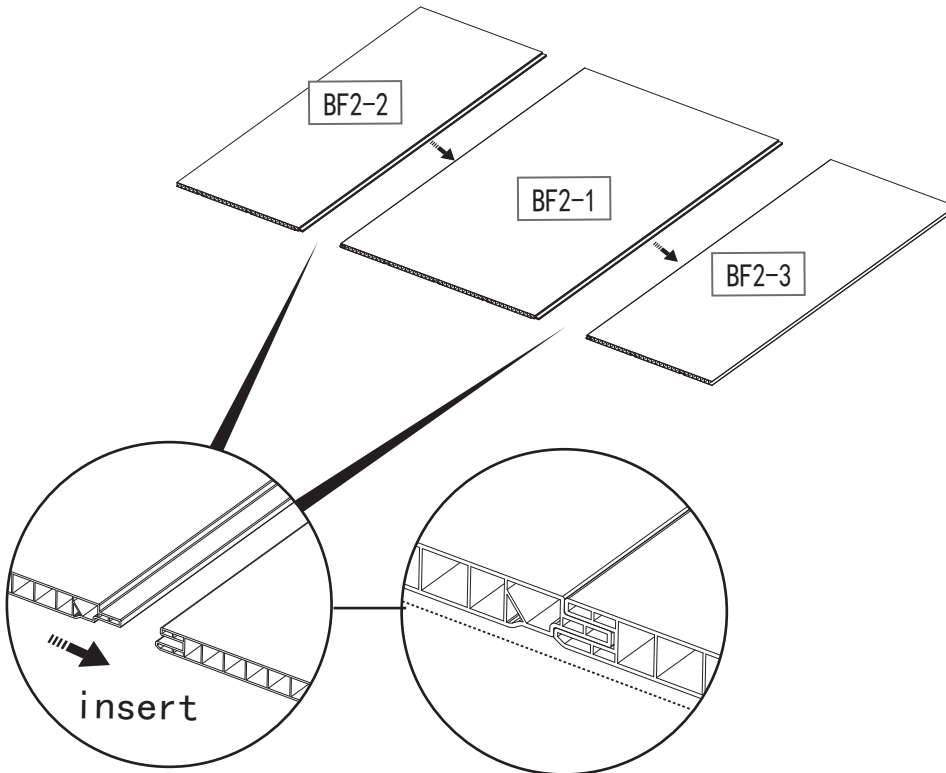

● Grain should be down

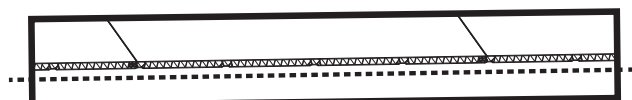

● Panels are in a straight line after installation.

Step 2

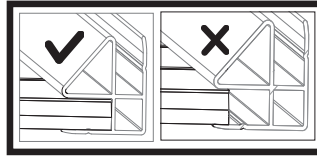

● Fully fit the panel inside the profile

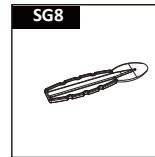

SG6		2 PC
BP4		2 PC
BP1		1 PC

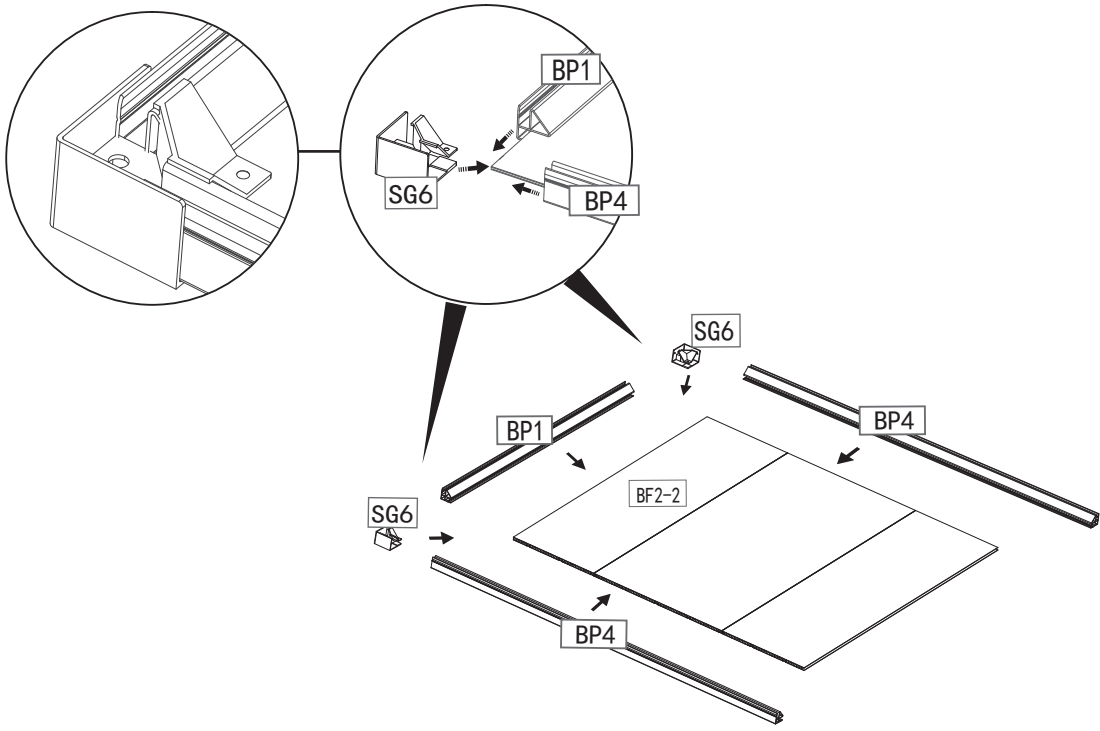

Step 3

SG6	BP9	BP5	BP8	SG7-1	SG7-2
2 PC	1 PC	1 PC	1 PC	1 PC	1 PC

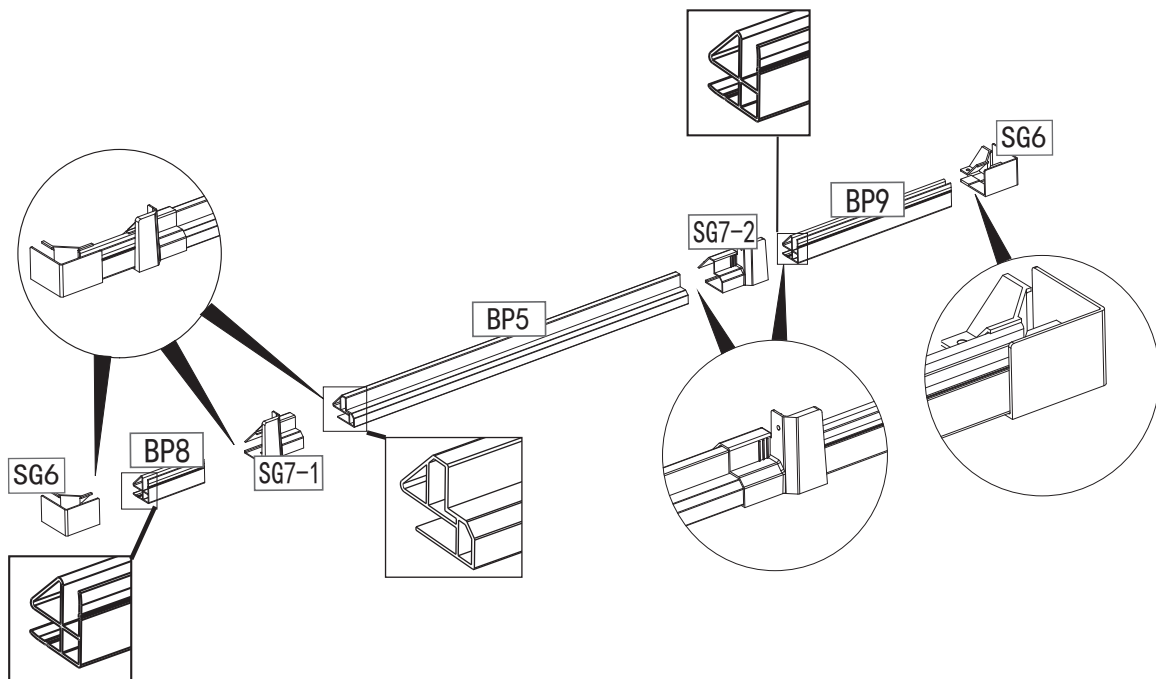

Step 4

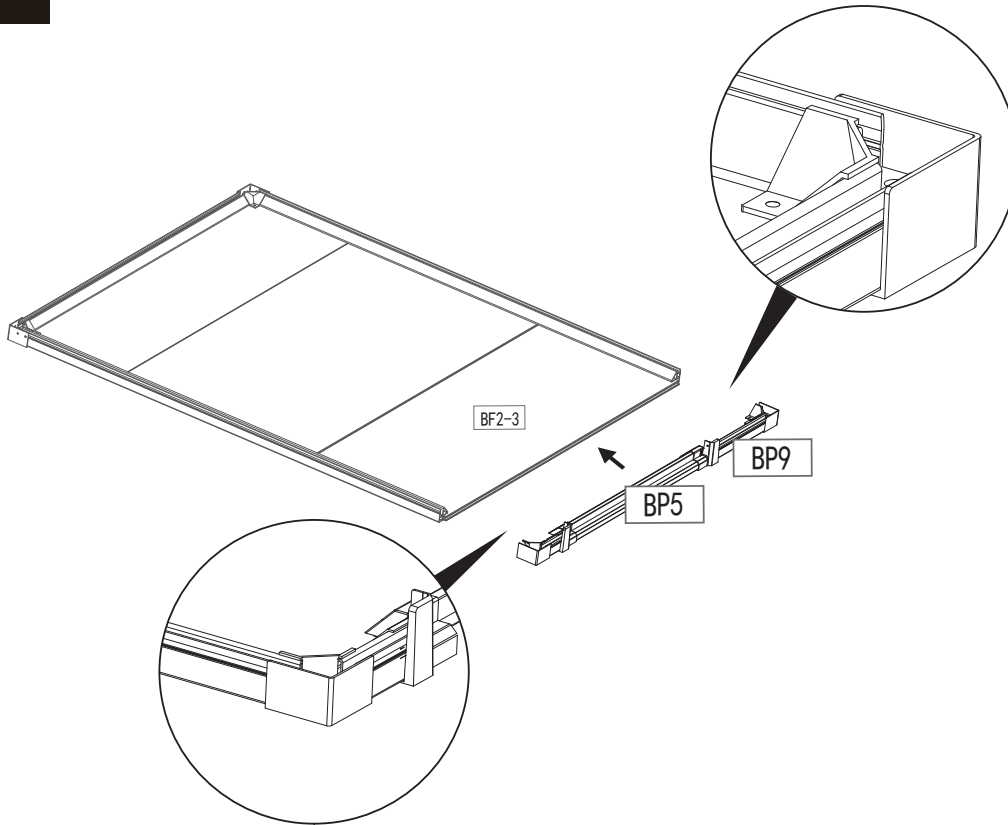

SG8

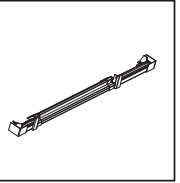

- Use spatula  (part "SG8") for easier insertion of panel into profile

Step 5

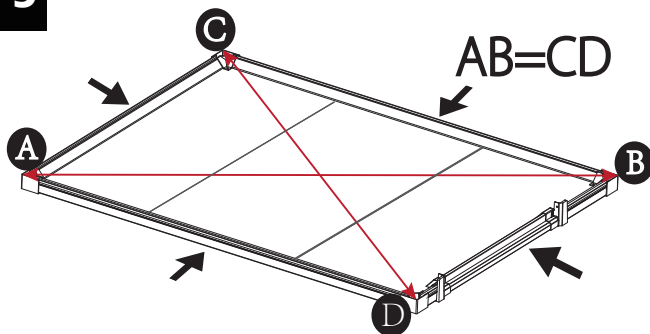

Z410



4 PC

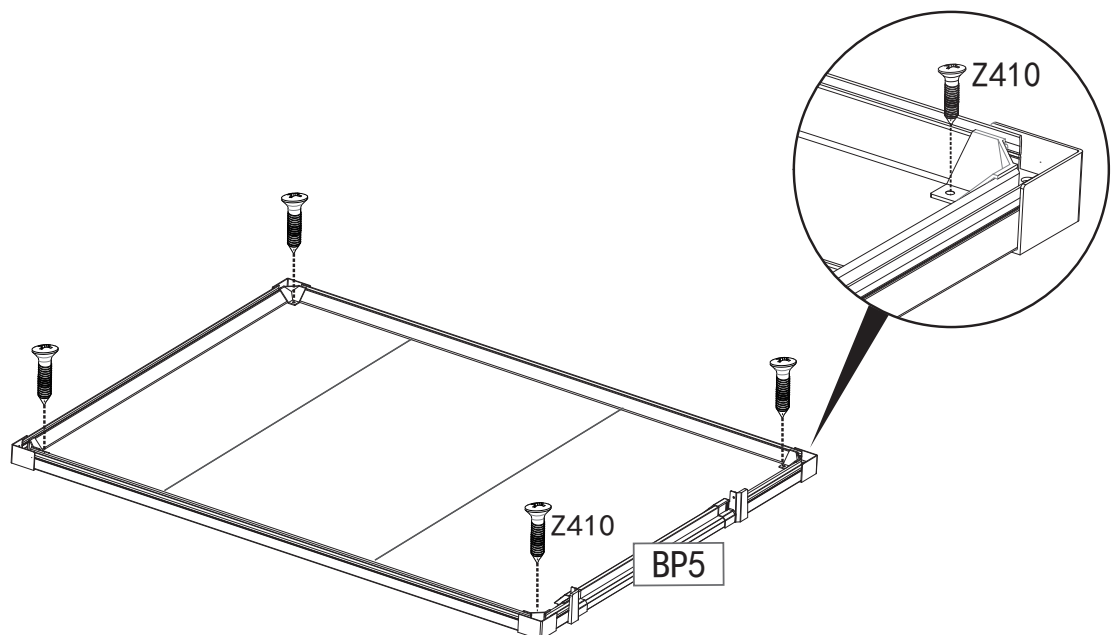

Step 6

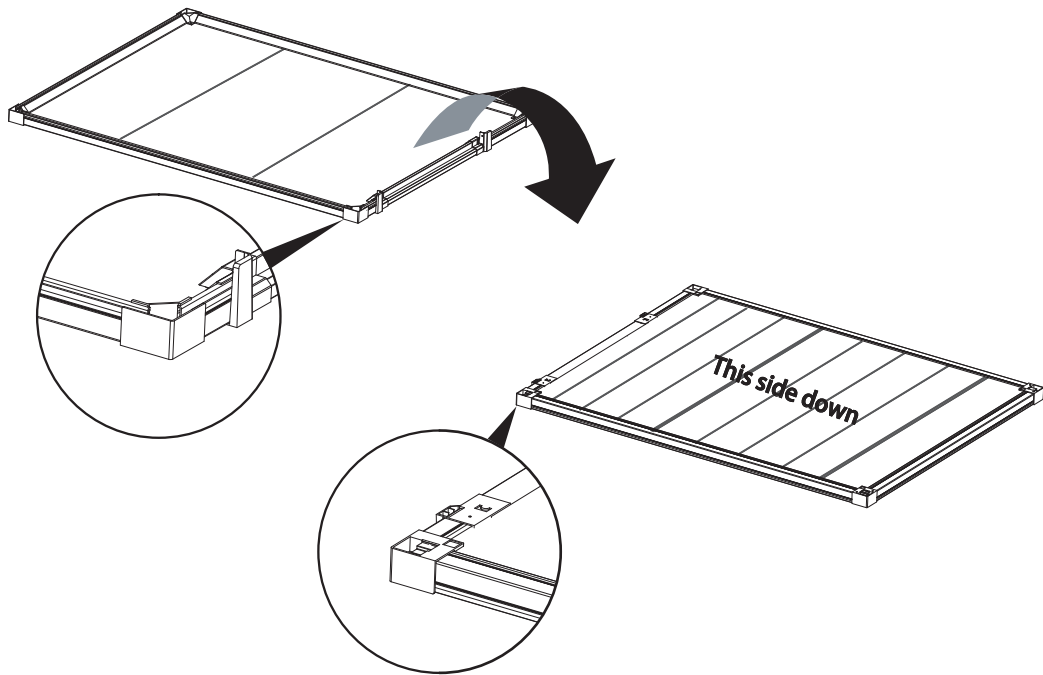

Step 7

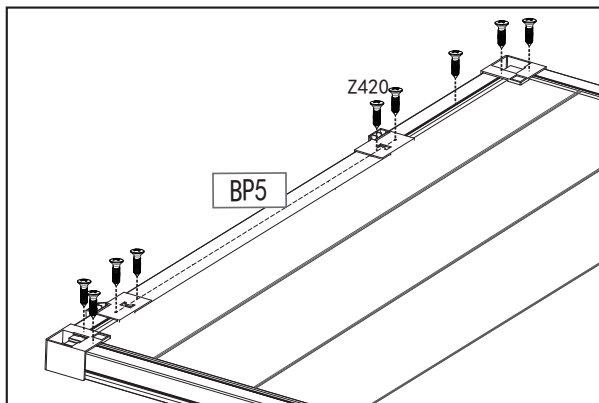

Z420



9 PC

Caution:

Please use Drill  to predrill a hole at depth 1mm before screw.

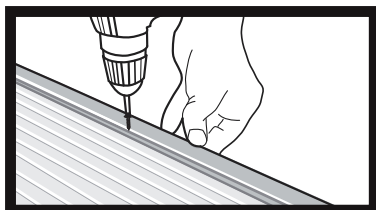

●Nail along the marked line on profile

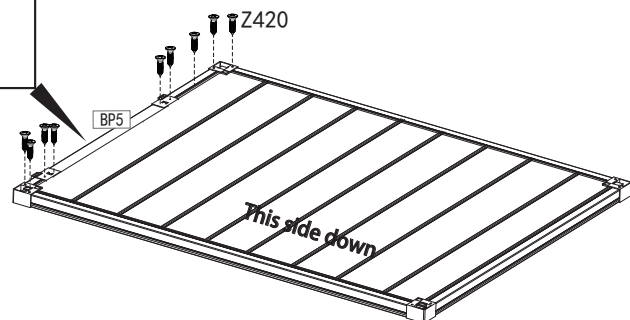

Step 8

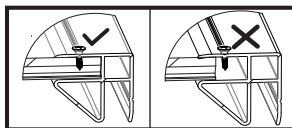

●Nail along the marked line on profile.

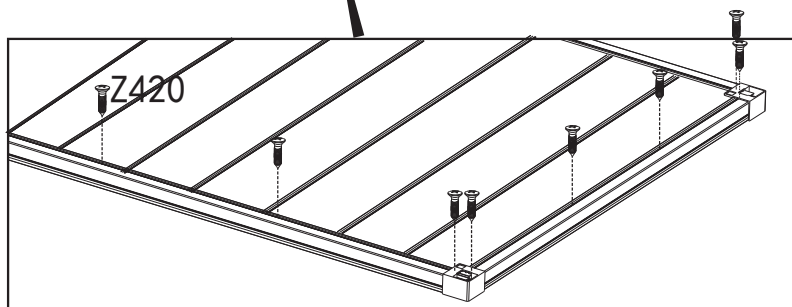
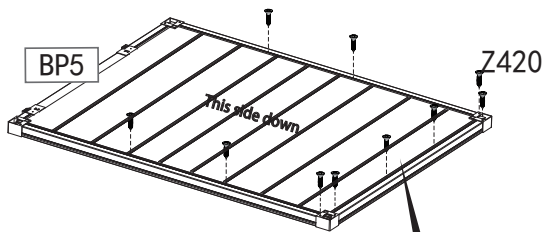
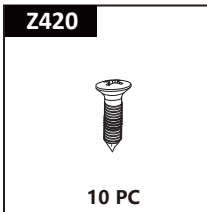

Caution:
Please use Drill to predrill
a hole at depth 1mm before screw.

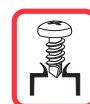

Step 9

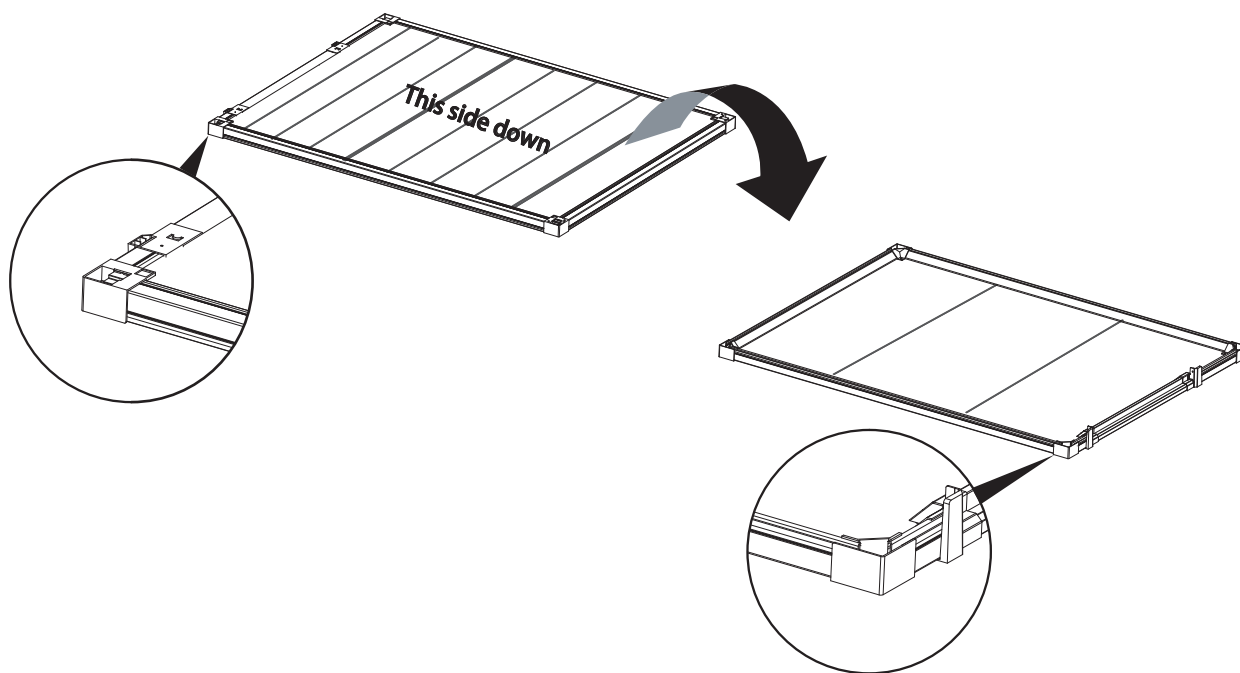

FLOOR ASSEMBLY



● Use spatula (part "SG8") for easier insertion of panel into profile.

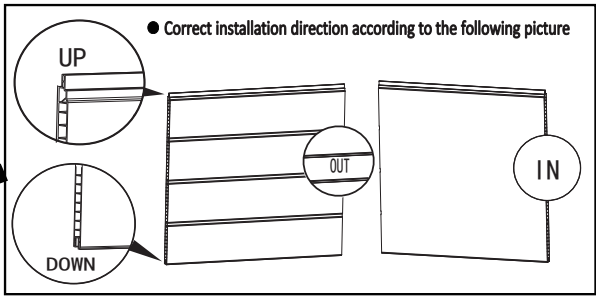
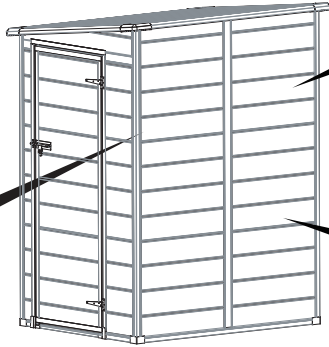

● Correct installation direction according to the following picture

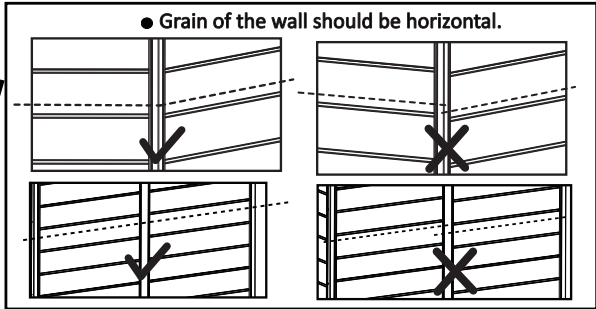

● Grain of the wall should be horizontal.

Step 10

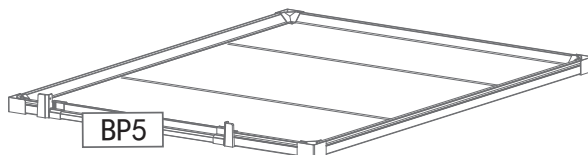
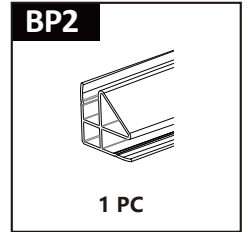
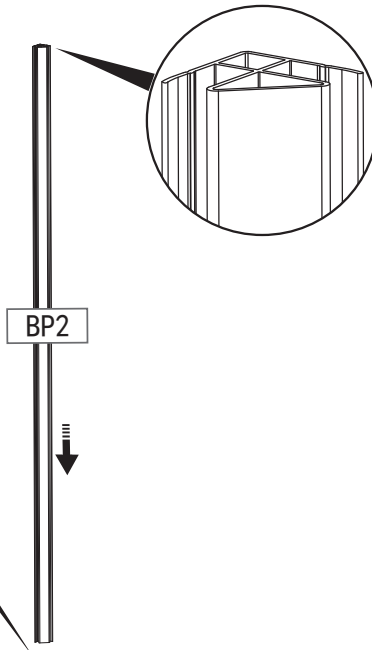
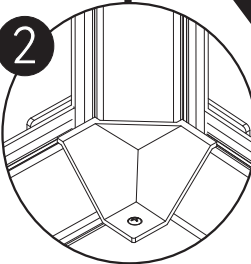
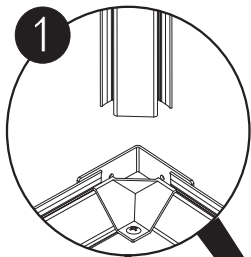

Step 11

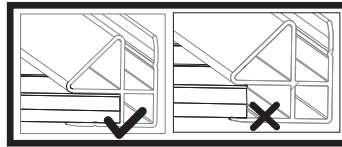

● Fully fit the panel inside the profile

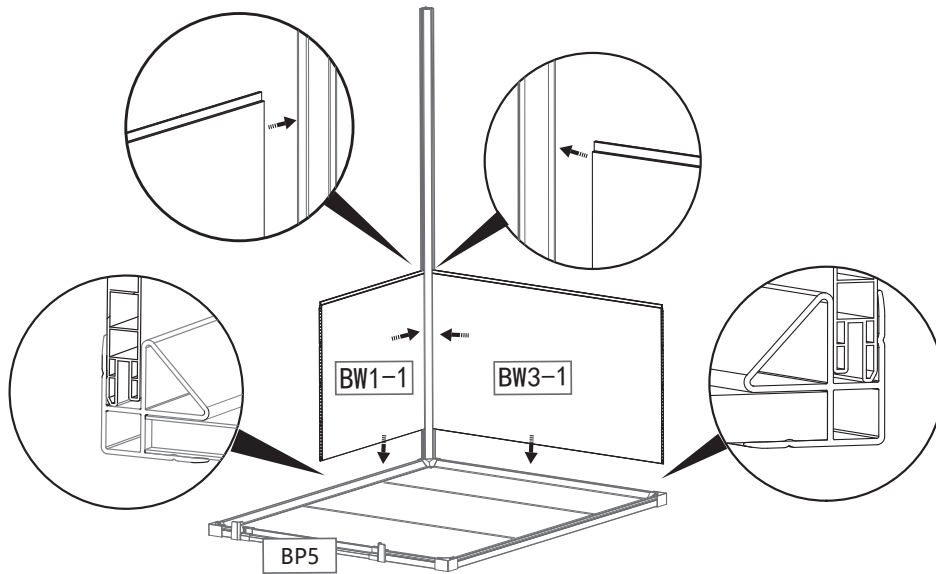

BW1-1
1 PC
BW3-1
1 PC
SG8

Step 12

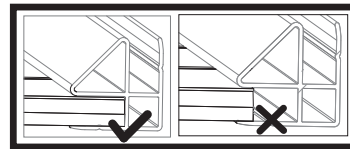

● Fully fit the panel inside the profile

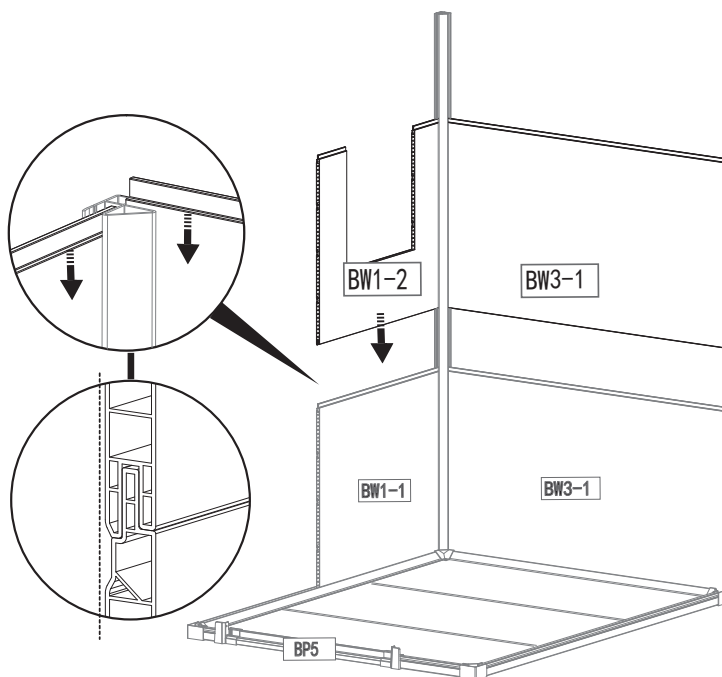

BW1-2
1 PC
BW3-1
1 PC
SG8

Step 13

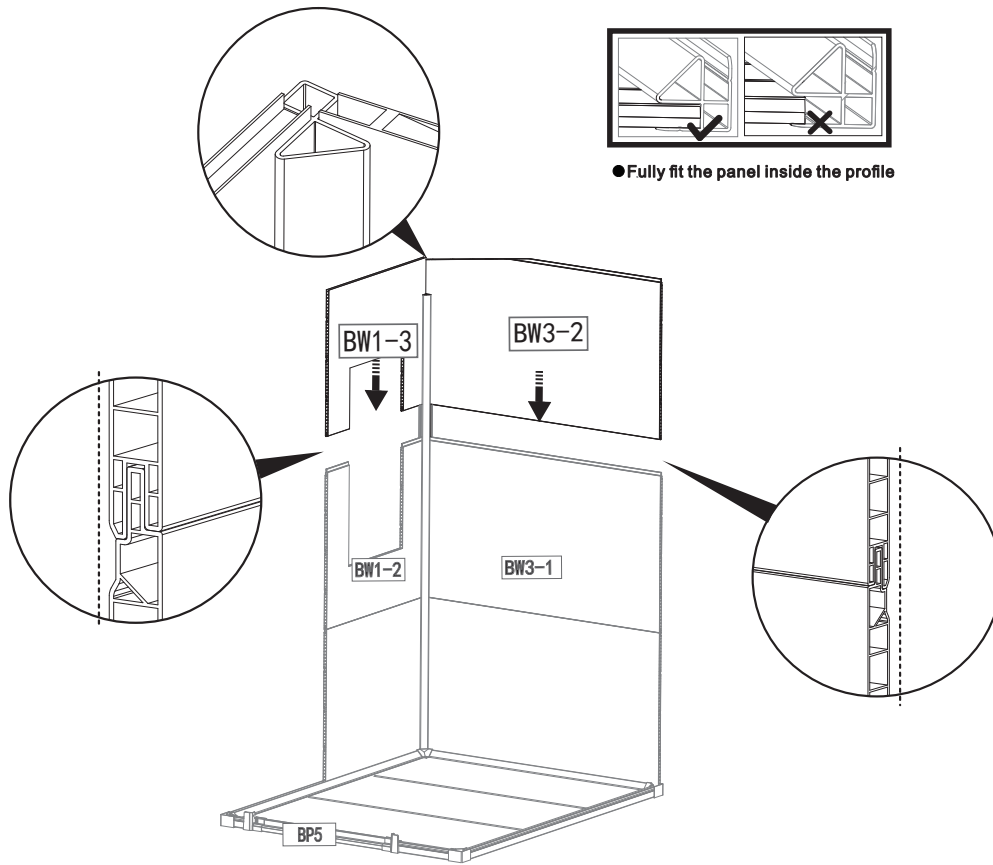

BW1-3

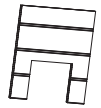

1 PC

BW3-2

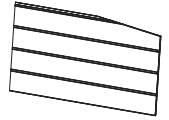

1 PC

SG8

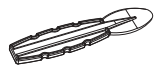

Step 14

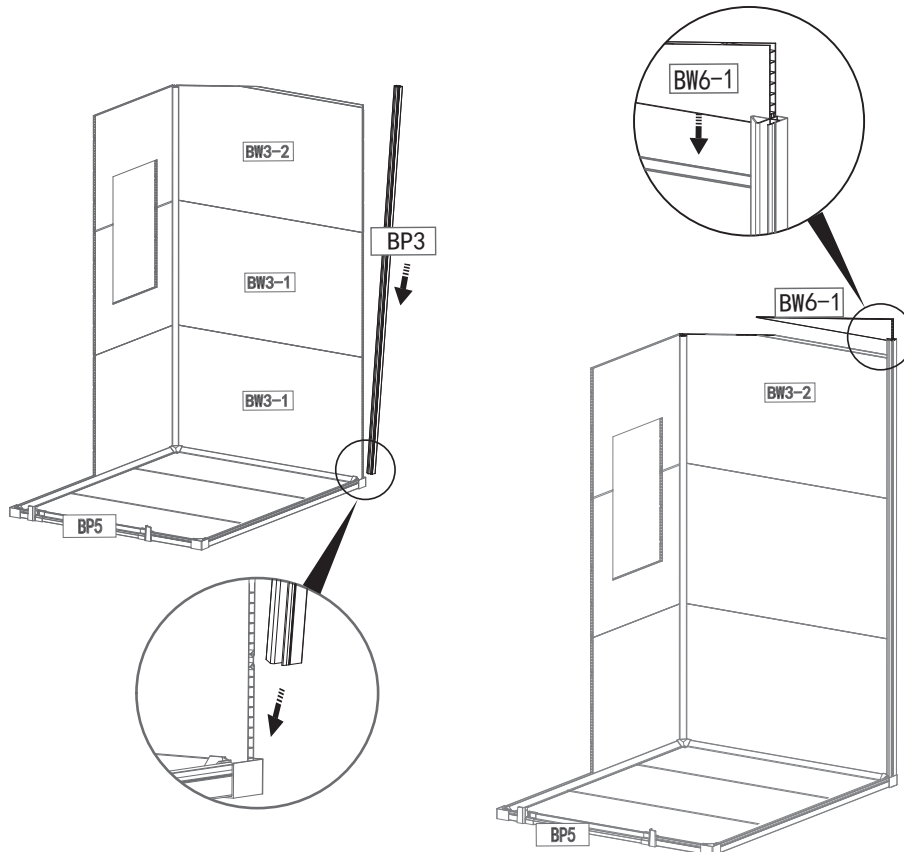

BP3

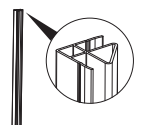

1 PC

BW6-1



1 PC

SG8

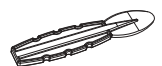

Step 15

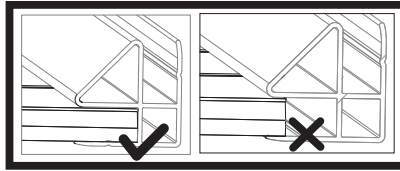

● Fully fit the panel inside the profile

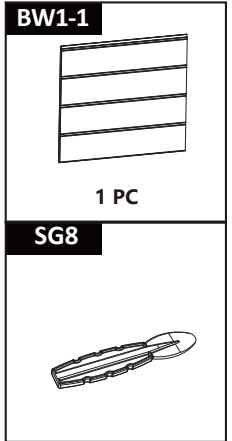
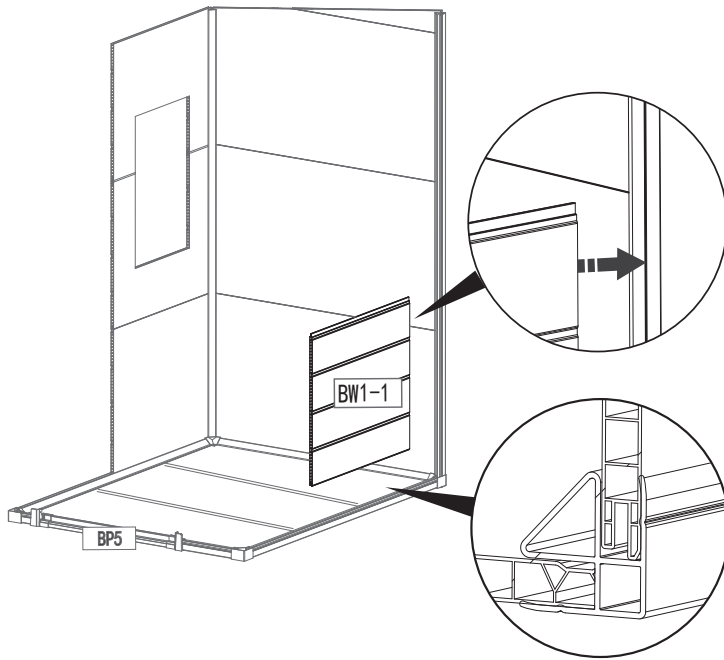

Step 16

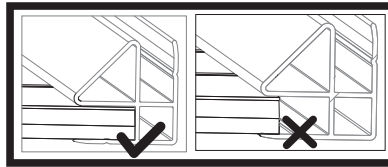

● Fully fit the panel inside the profile

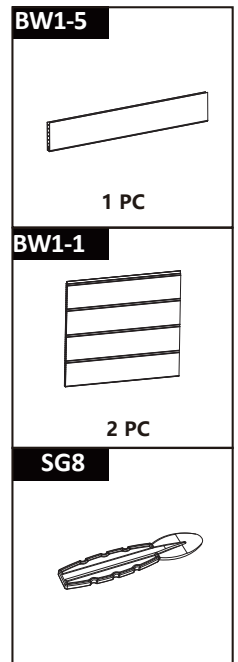
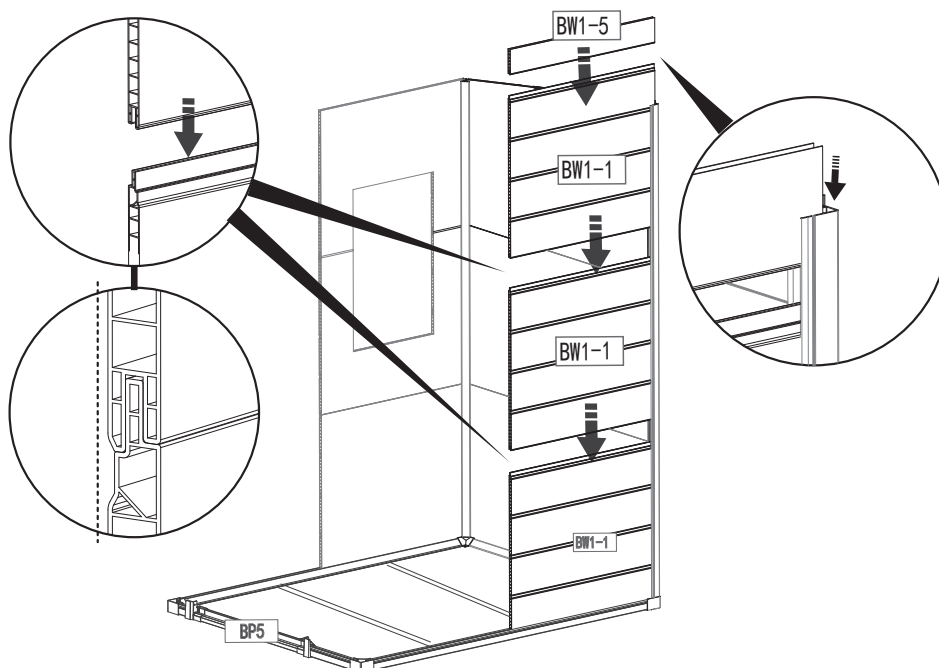

Step 17

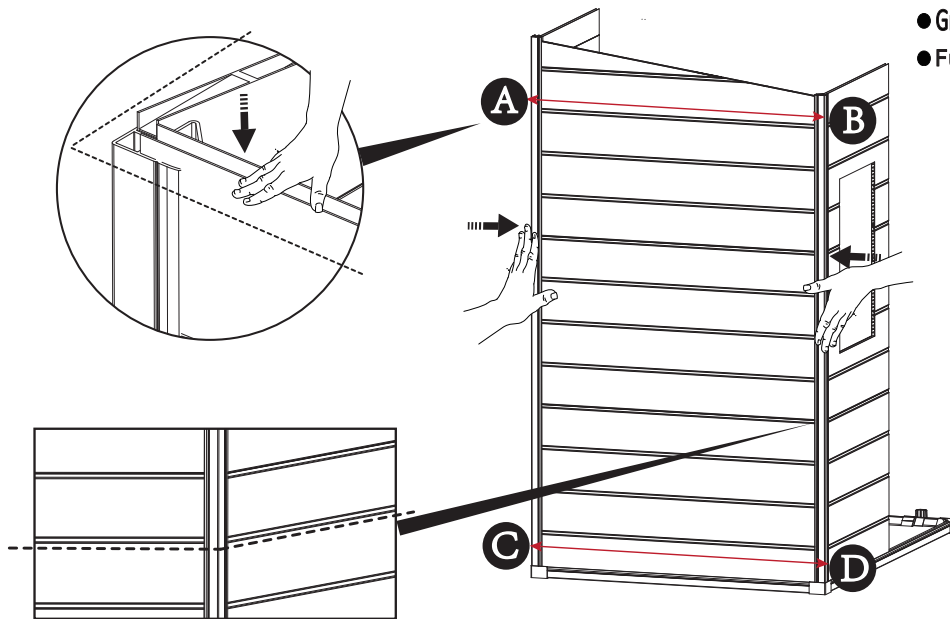

- Ensure AB equal to CD before nailing.
- Grain of the wall should be horizontal.
- Fully fit the panel inside the profile.



Step 18

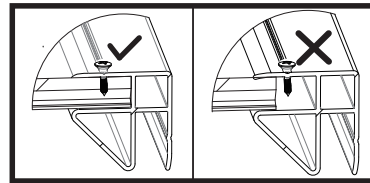

● Nail along the marked line on profile.

Z420



18 PC

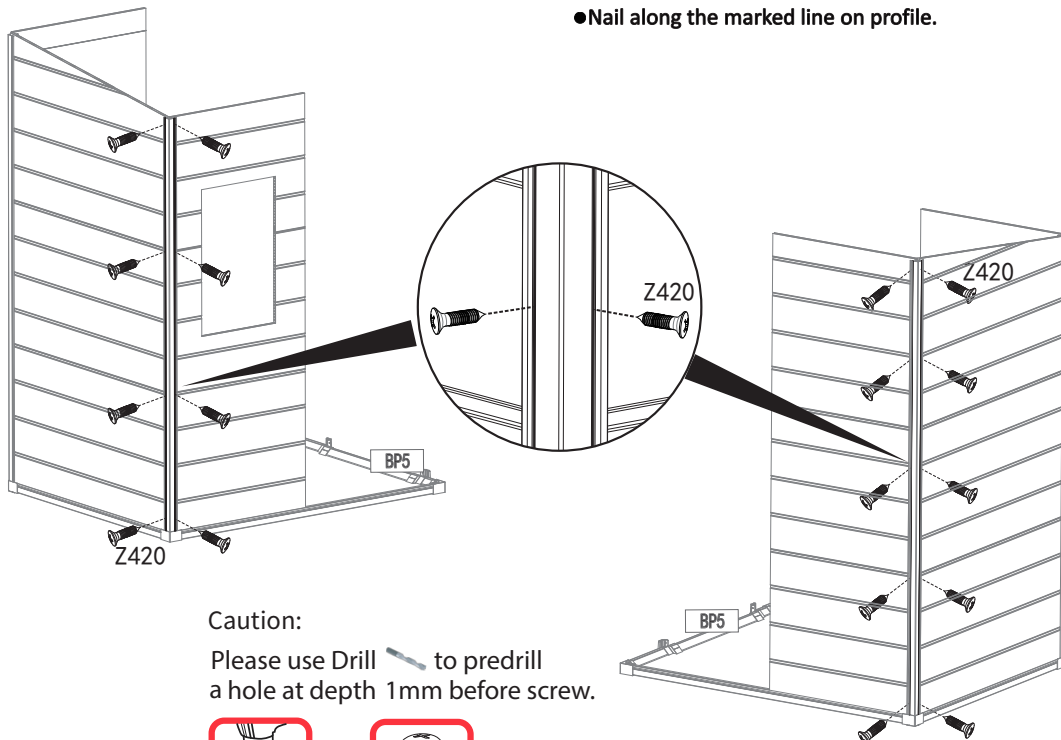

Caution:
Please use Drill to predrill
a hole at depth 1mm before screw.



Step 19

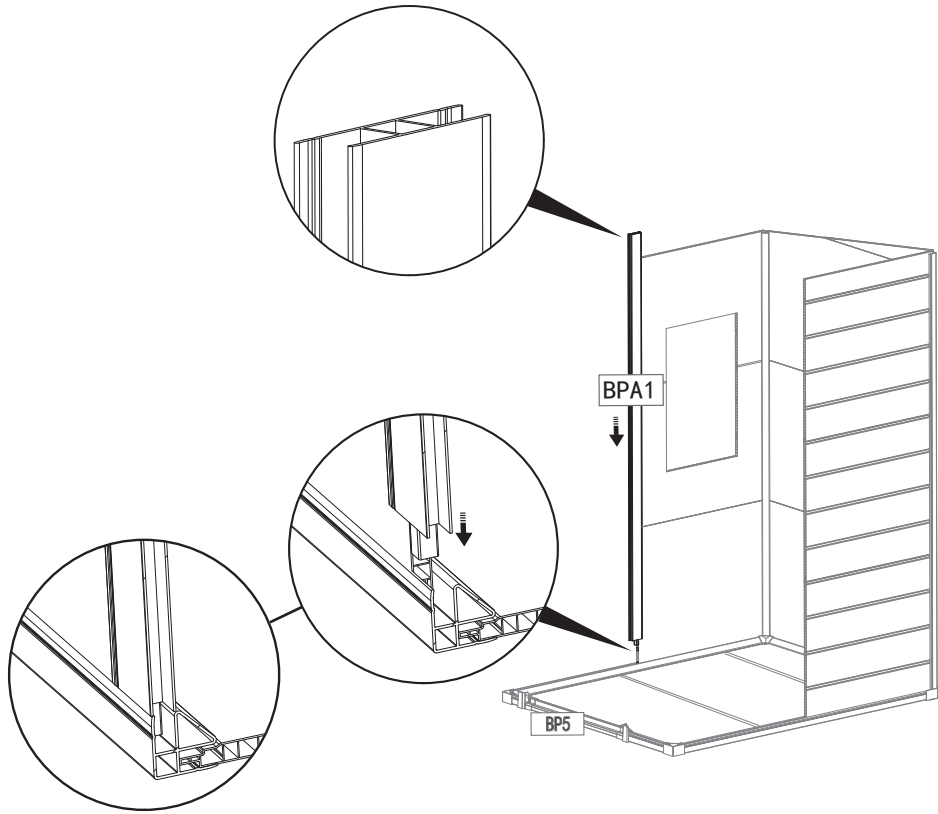

BPA1

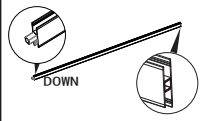

1 PC

SG8

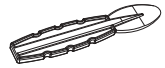

Step 20

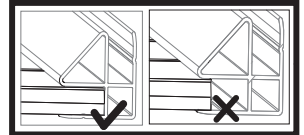
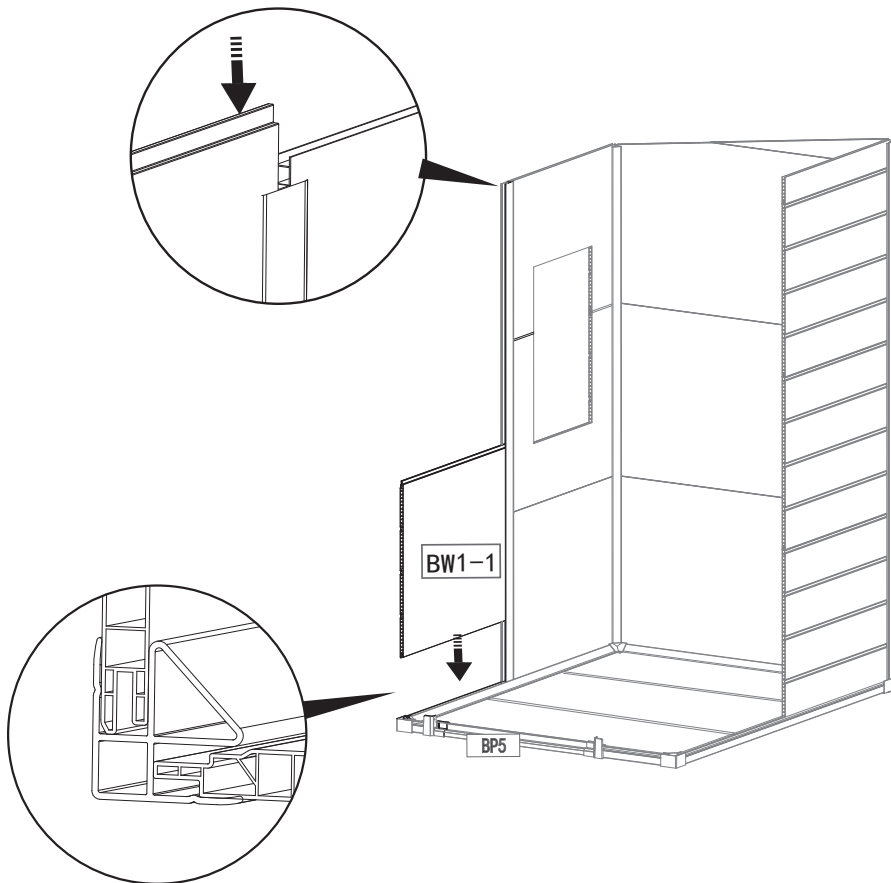

● Fully fit the panel inside the profile

BW1-1



1 PC

SG8

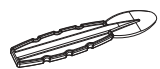

Step 21

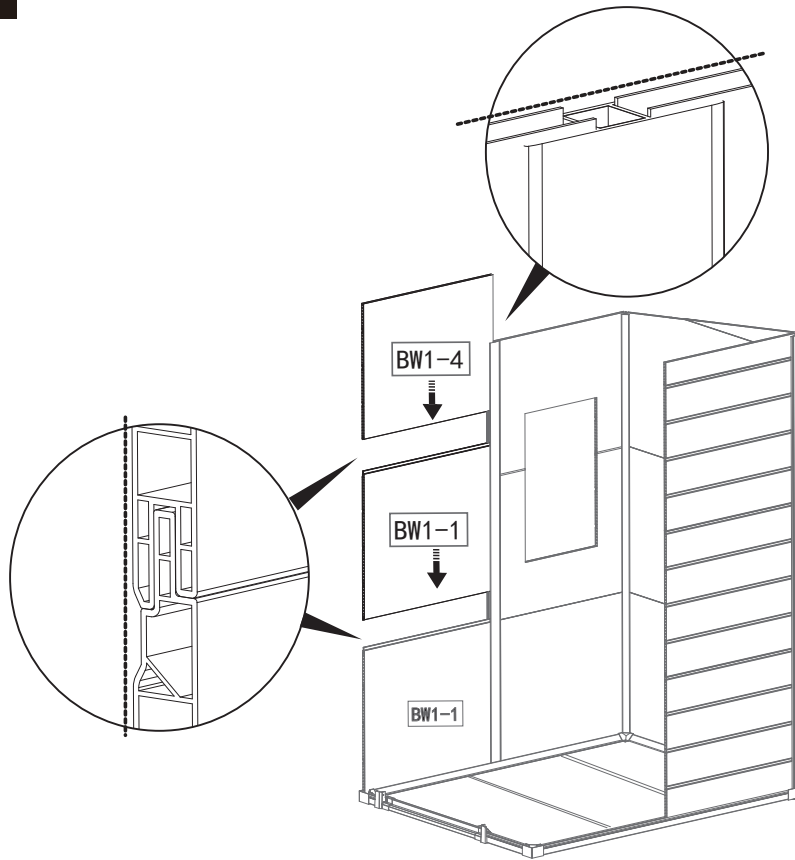

BW1-4



1 PC

BW1-1



1 PC

SG8



Step 22

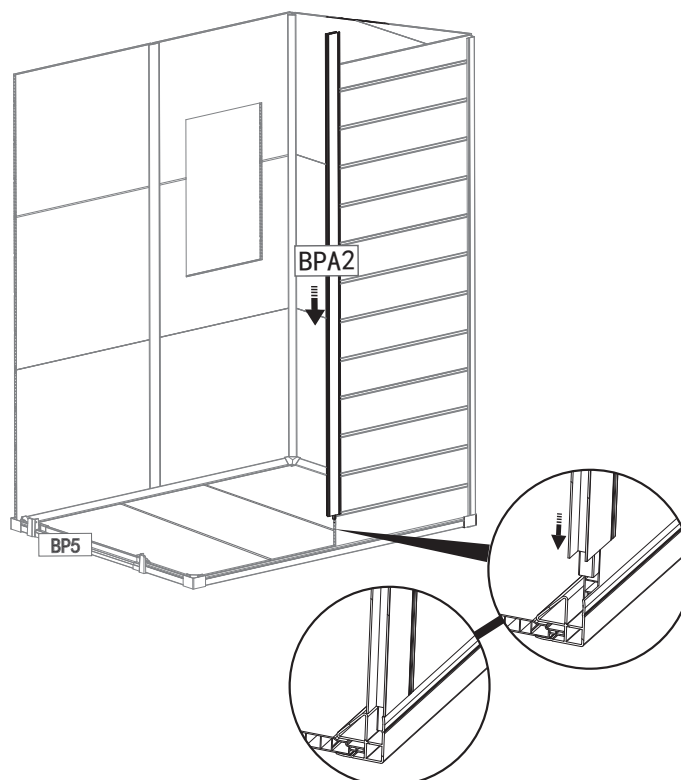

BPA2

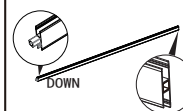

1 PC

SG8



Step 23

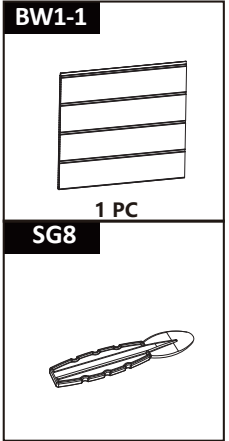
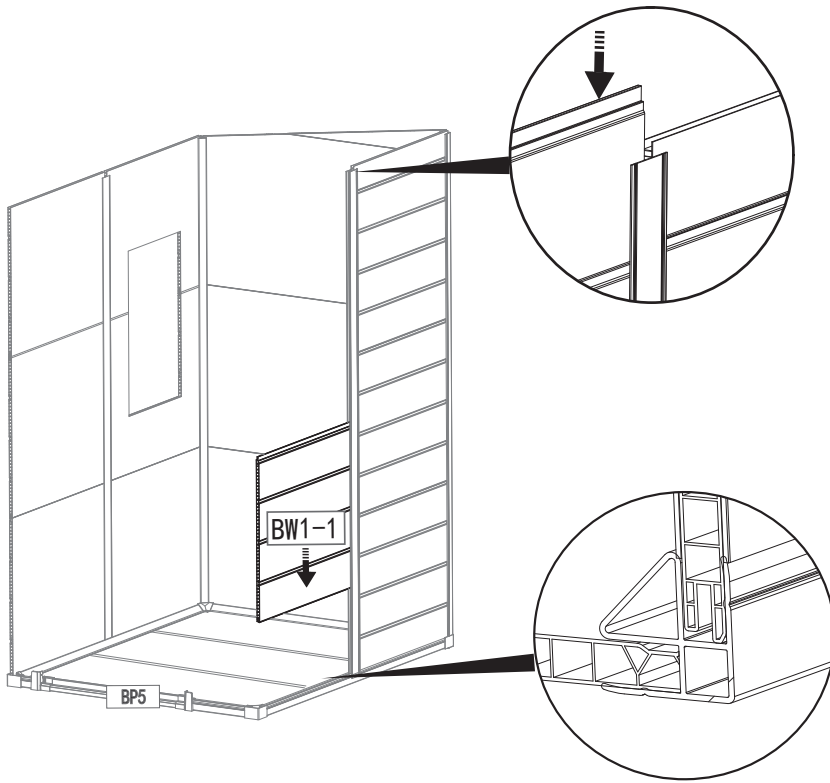

Step 24

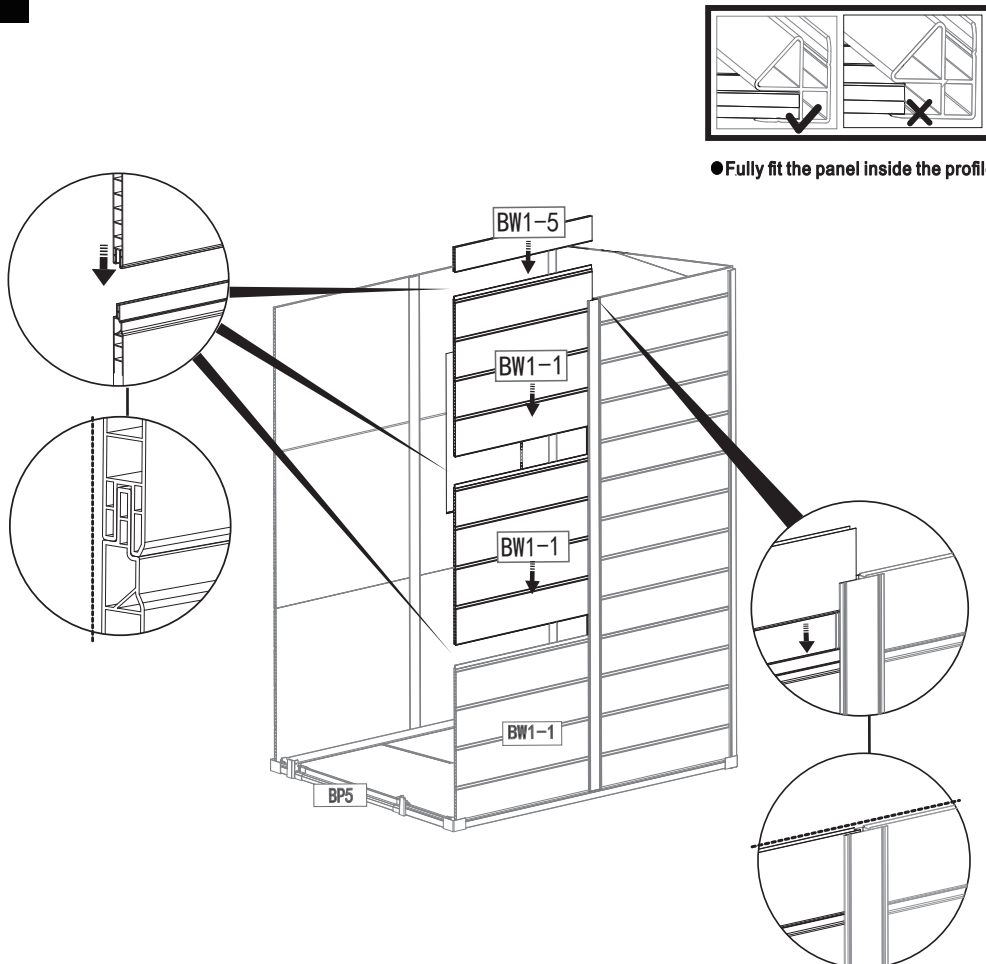

● Fully fit the panel inside the profile

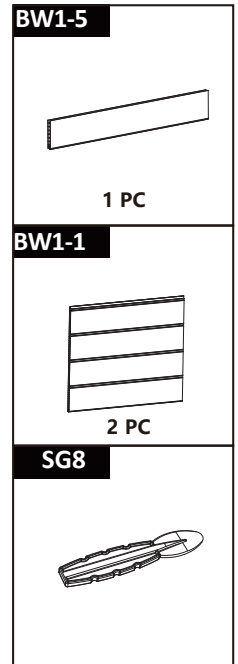

Step 25

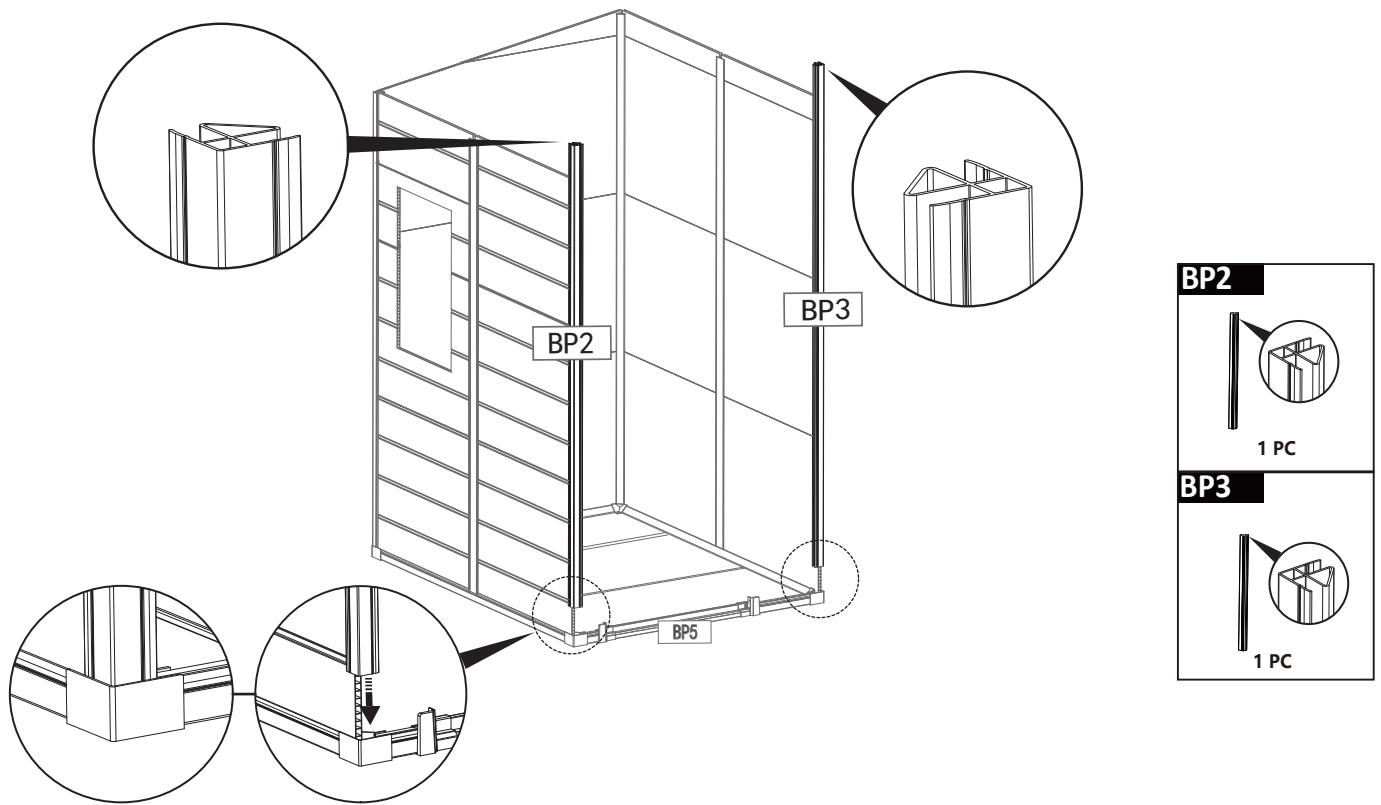

Step 26

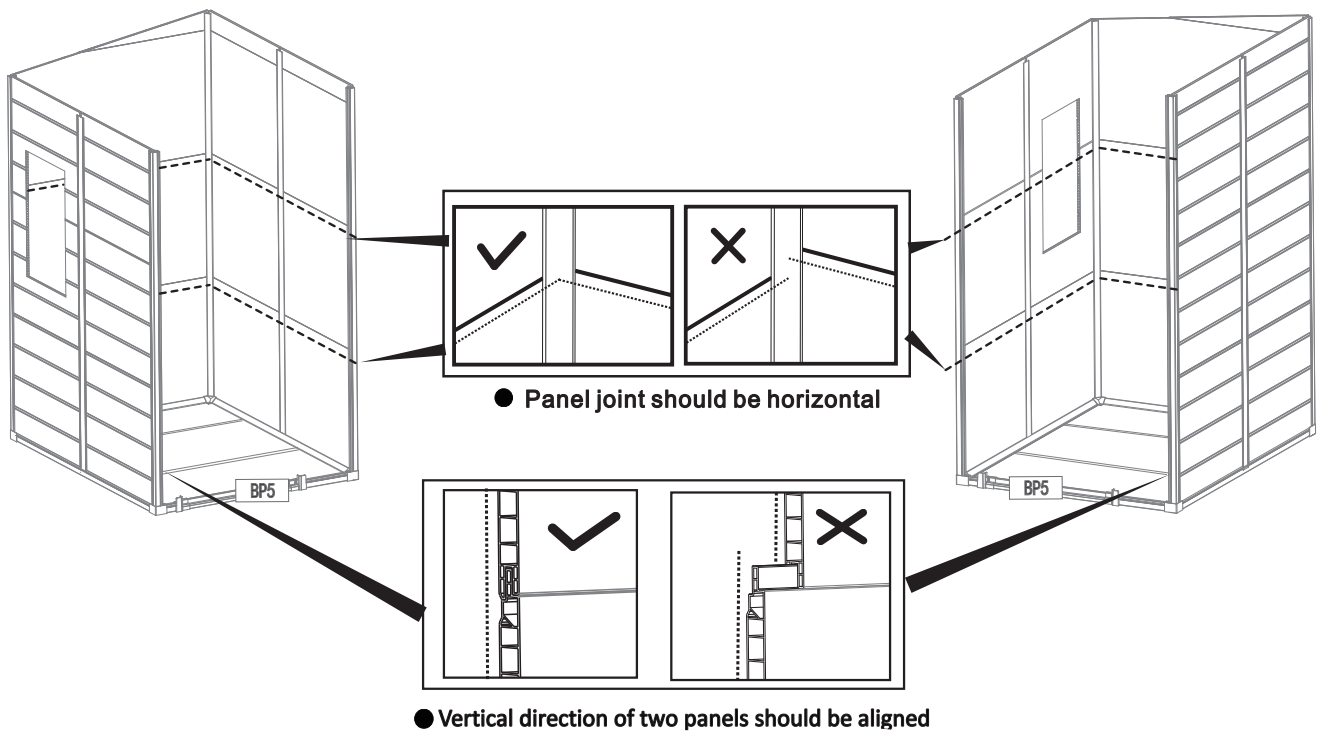

Step 27

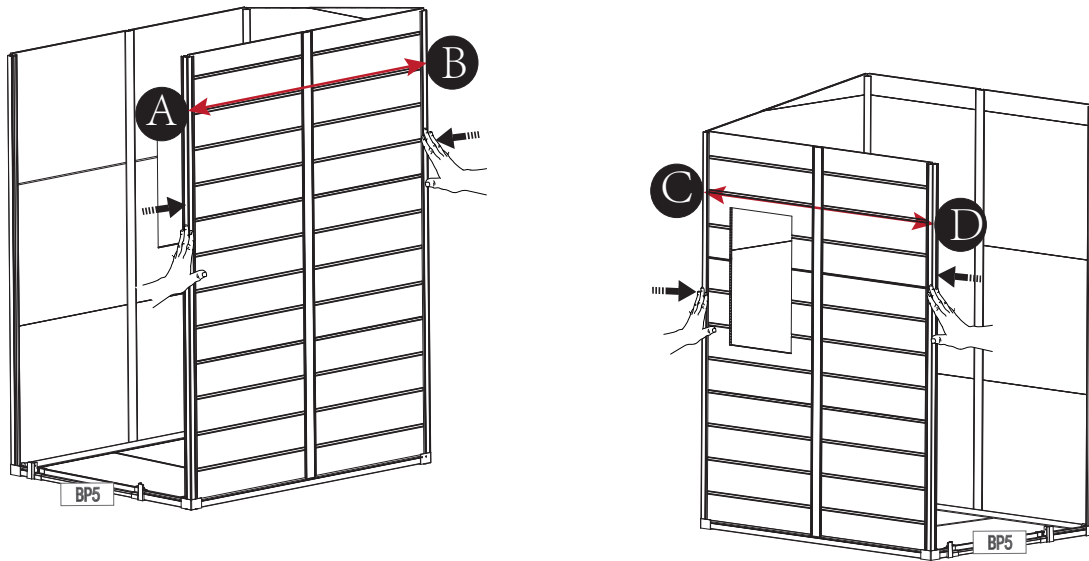

● Make sure $AB=CD$

Step 28

● Screw when the boards are in position

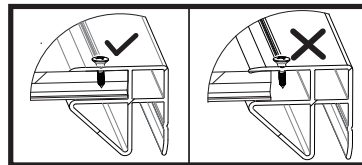



● Nail along the marked line on profile.

Z420

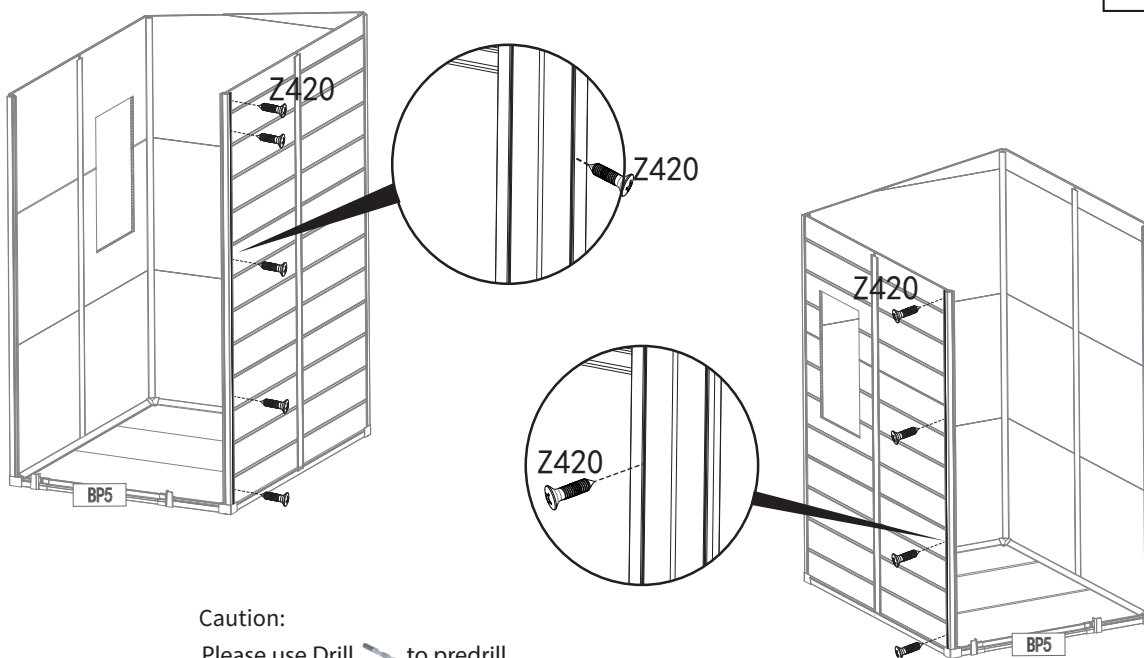

9 PC



Caution:
Please use Drill  to predrill
a hole at depth 1mm before screw.



Step 29

Caution:
Please use Drill  to predrill
a hole at depth 1mm before screw.

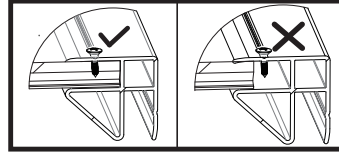
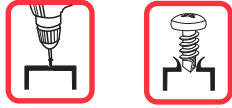

● Nail along the marked line on profile.

Z410



16 PC

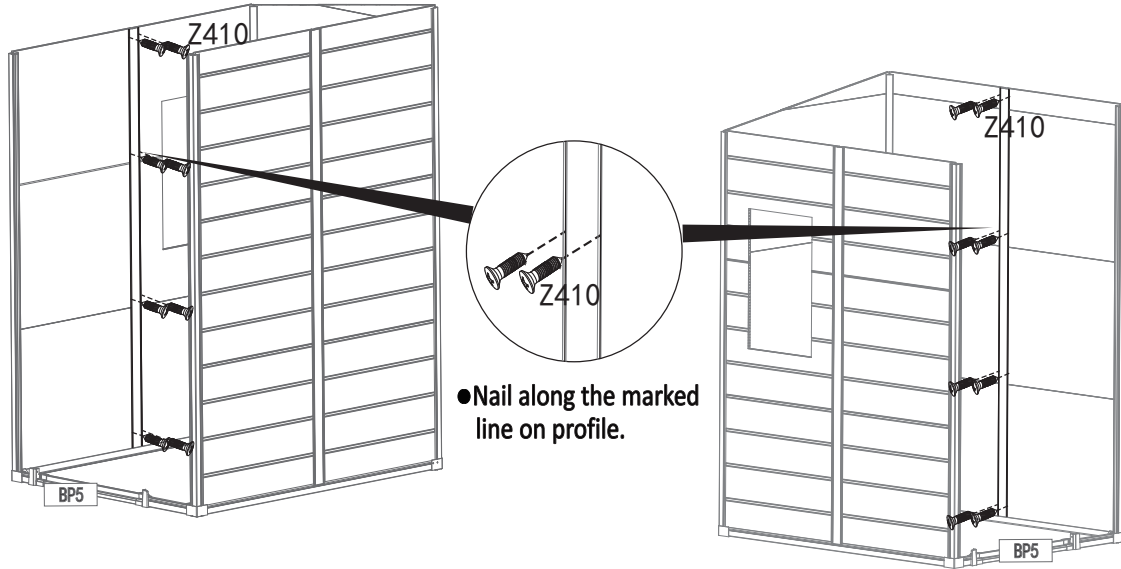

Step 30

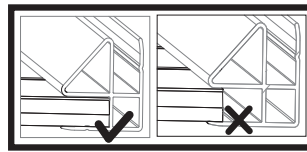

● Fully fit the panel inside the profile

BW4-2



1 PC

BW5-2



1 PC

SG8

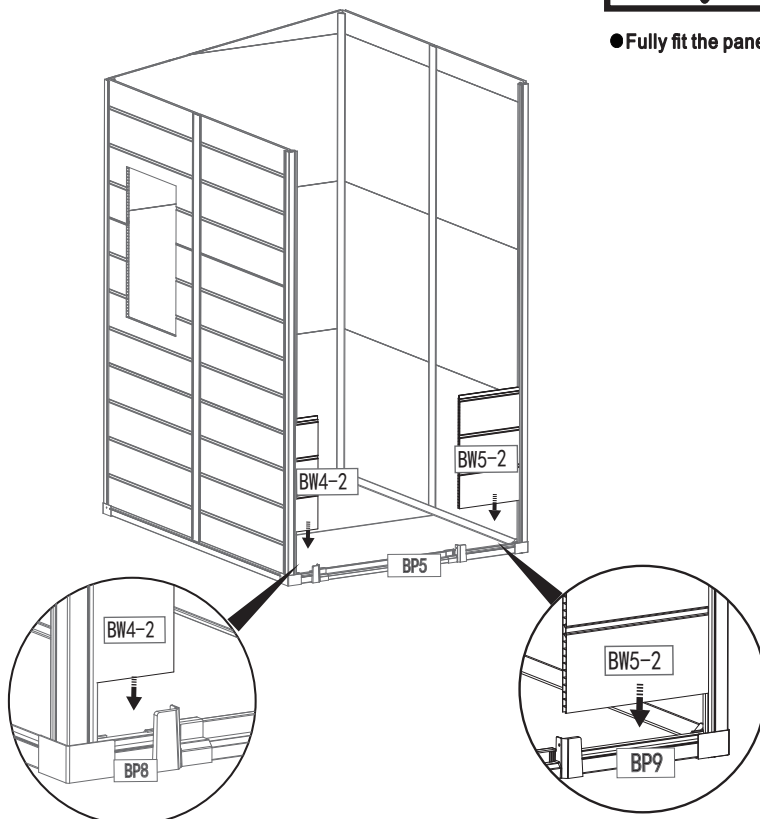

Step 31

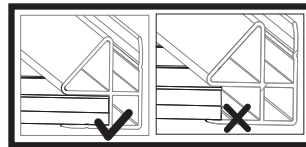

● Fully fit the panel inside the profile

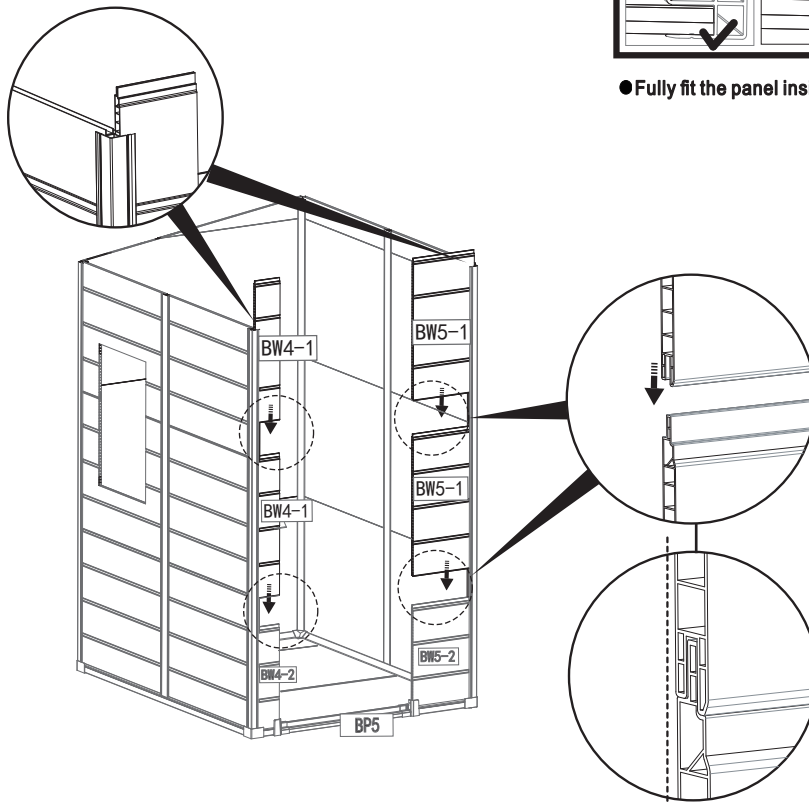

BW4-1



2 PC

BW5-1



2 PC

SG8



Step 32

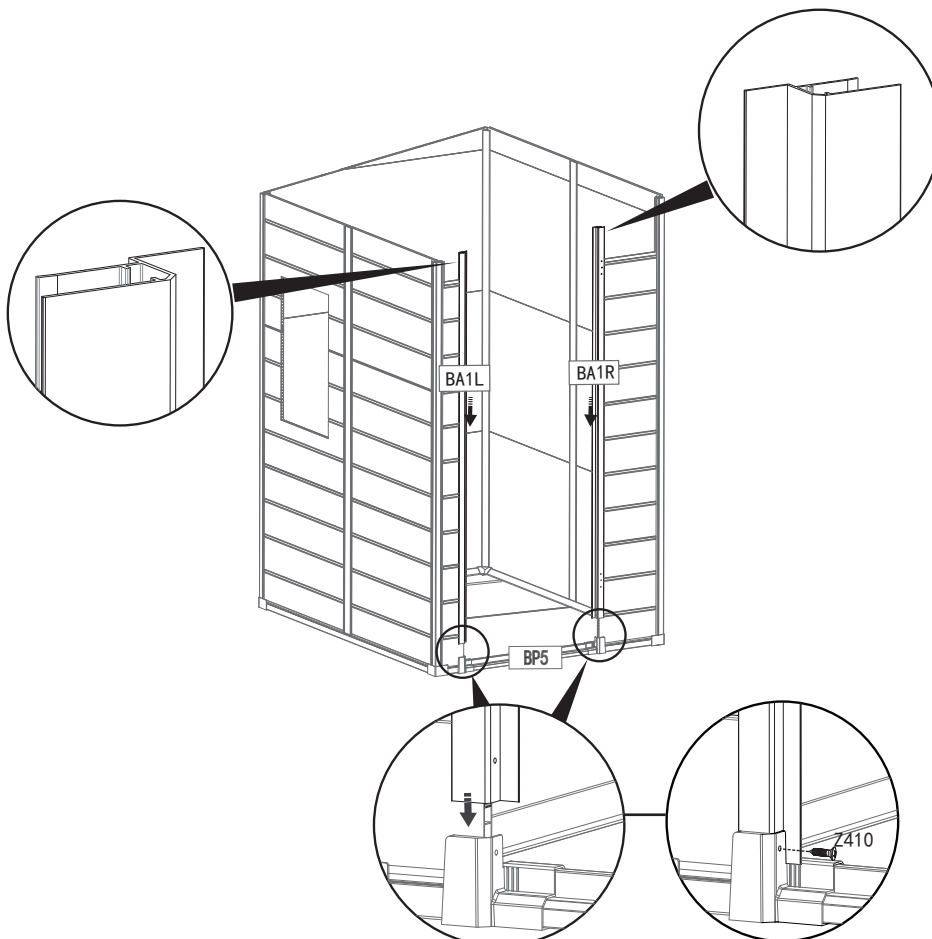

BA1L

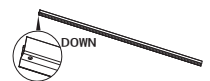

1 PC

BA1R

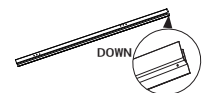

1 PC

Z410



2 PC

Step 33

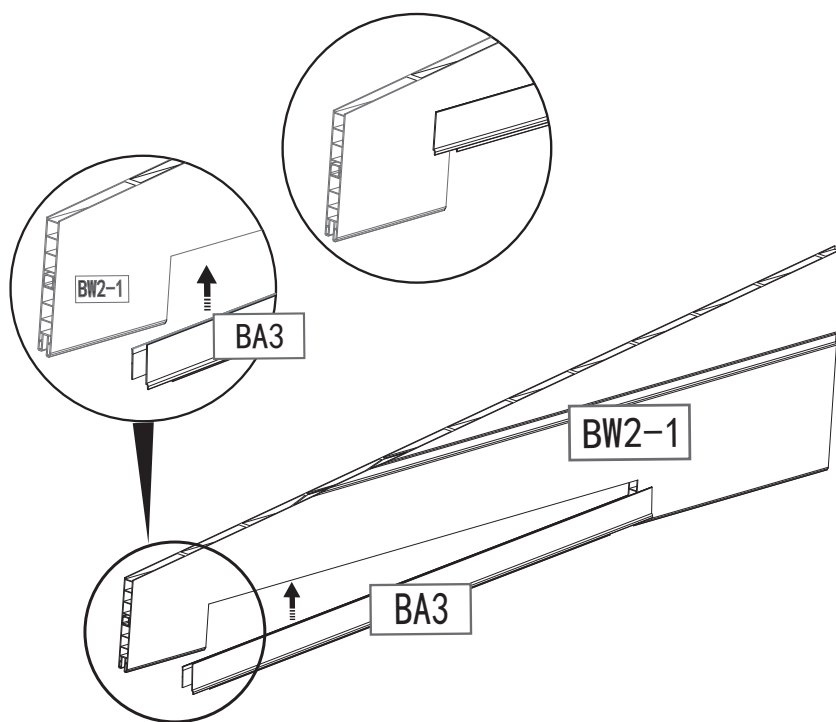

Step 34

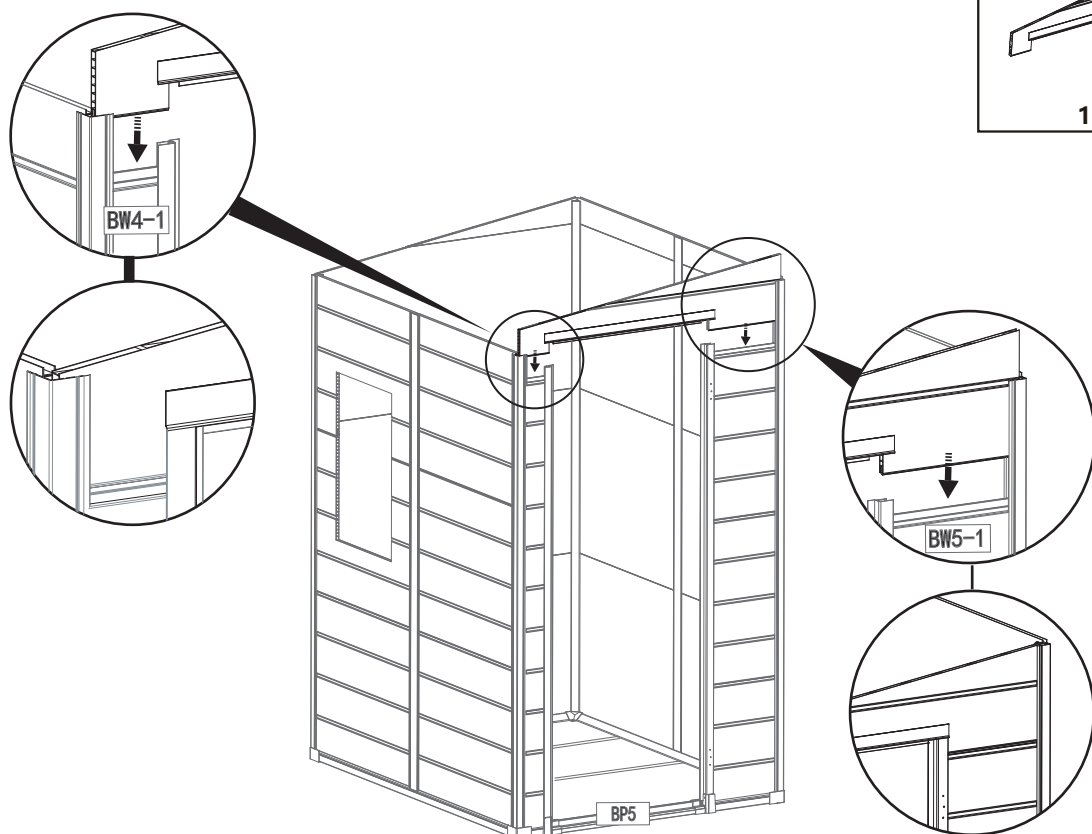

Step 35

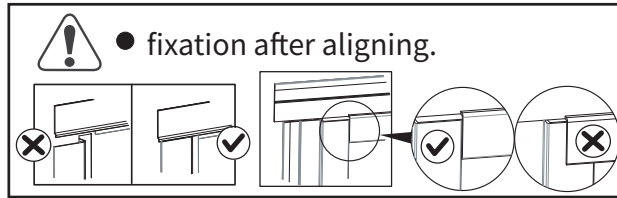

SG12



2 PC

ZW413



6 PC

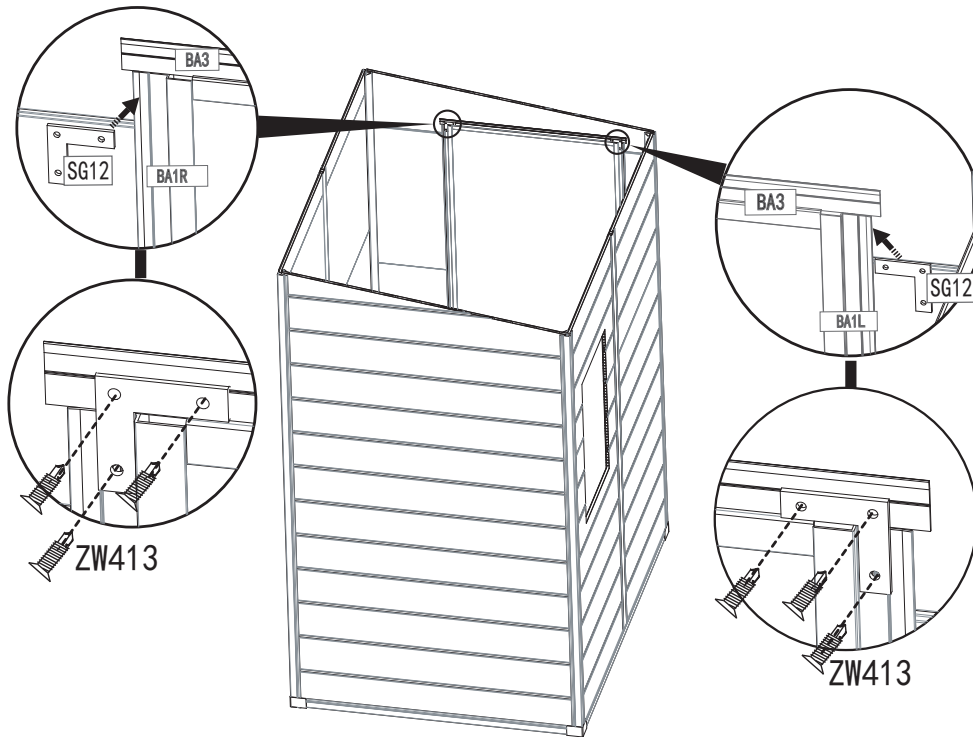

Step 36

● Make sure $AB=CD$

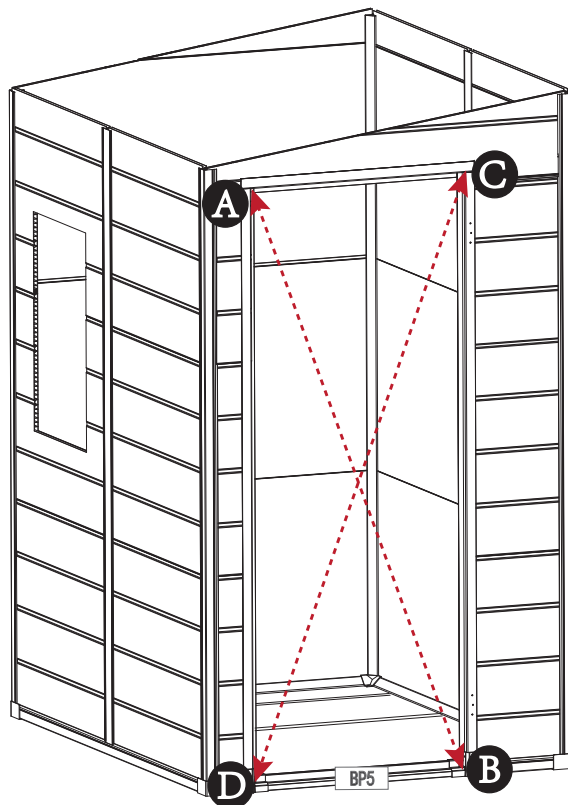

Step 37

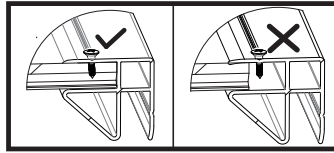

● Nail along the marked line on profile.

Z420



8 PC

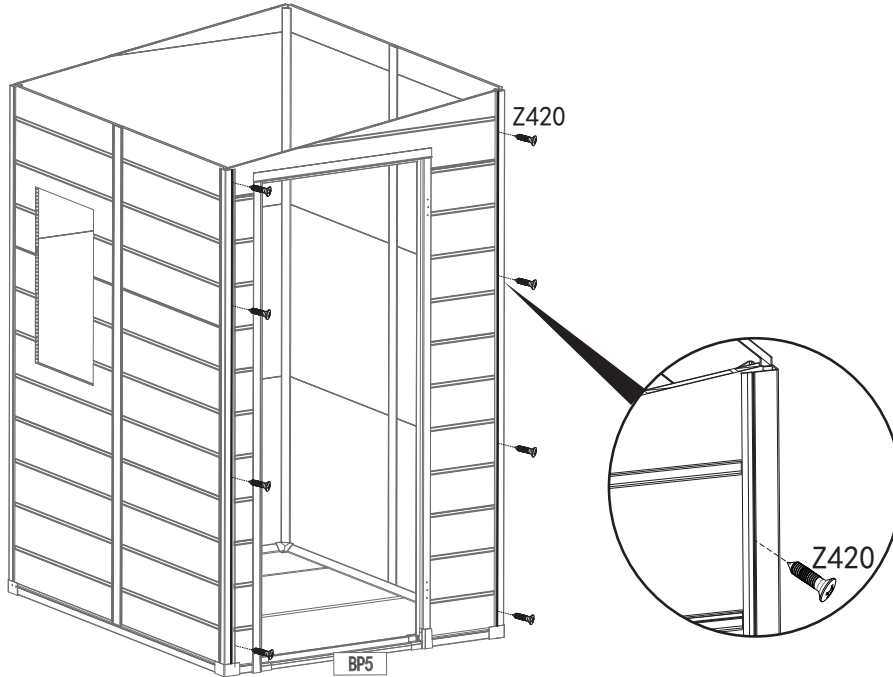

Caution:

Please use Drill to predrill a hole at depth 1mm before screw.



Step 38

Caution:

Please use Drill to predrill a hole at depth 1mm before screw.

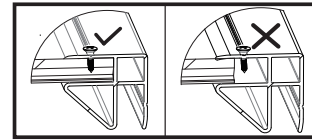

● Nail along the marked line on profile.

Z420



20 PC

- Fully fit the panel inside the profile
- Screw along the marked lines in profiles

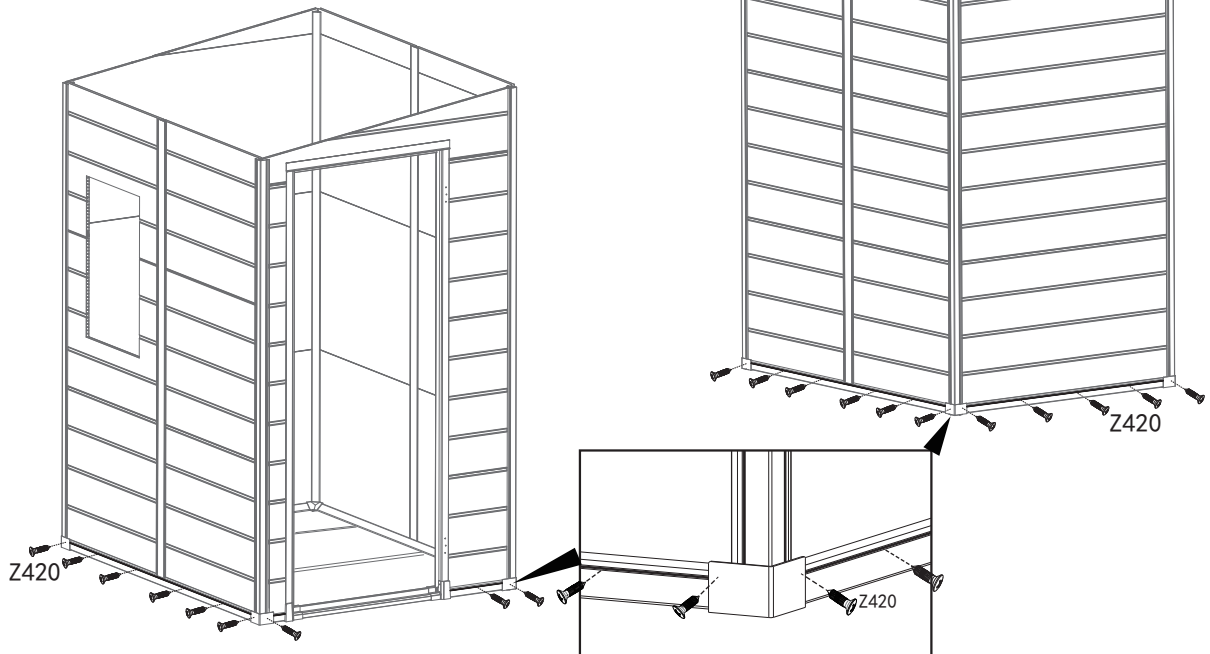

ROOF PARTS

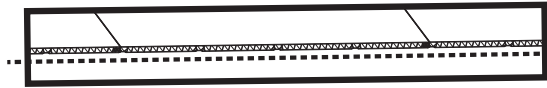

● The floor panels must be straight

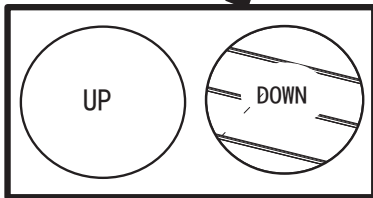
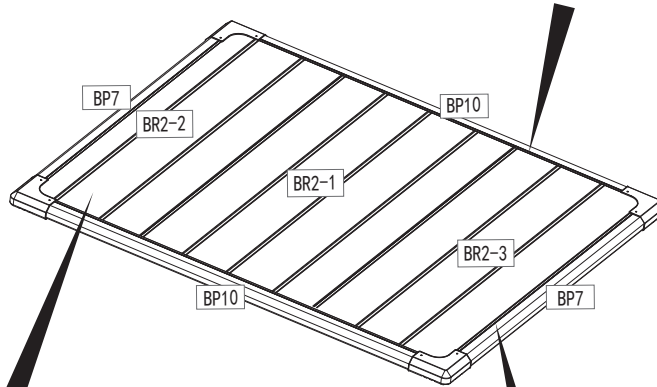

● Note: The crease line of the floor must be underneath

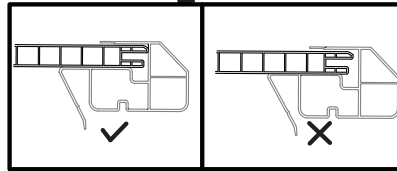

● Fully fit the panel inside the profile

Step 39

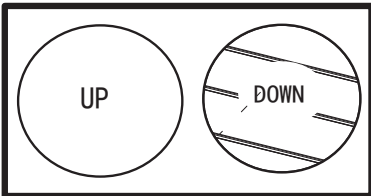

● Note: The crease line of the floor must be underneath

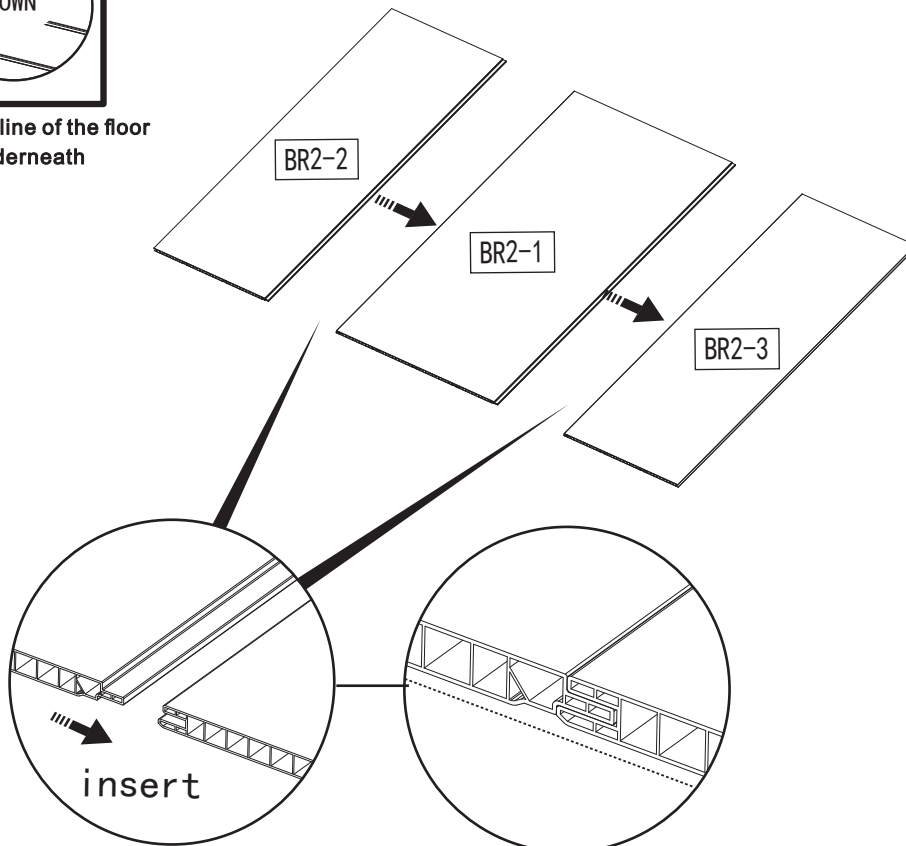

BR2-1		2 PC
BR2-2		1 PC
BR2-3		1 PC
SG8		

Step 40

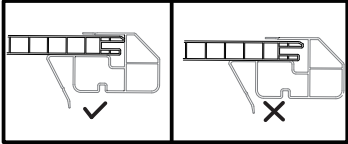

● Fully fit the panel inside the profile

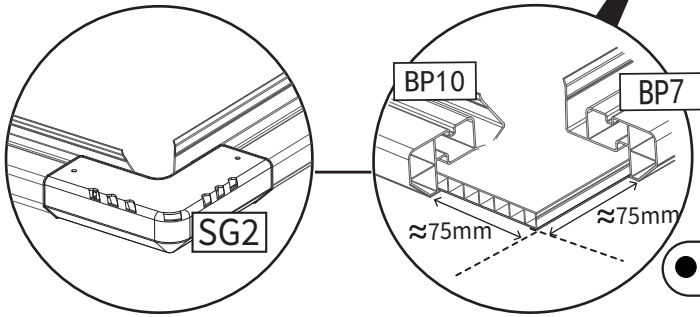
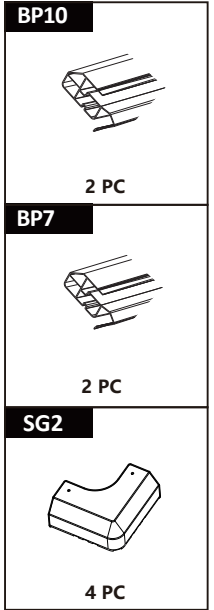
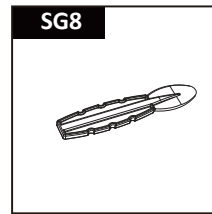
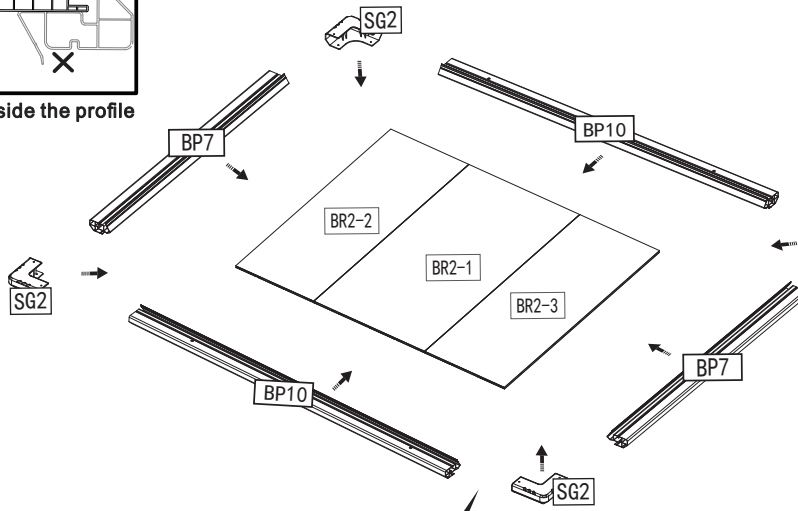

● Please note the measurement dimensions

Step 41

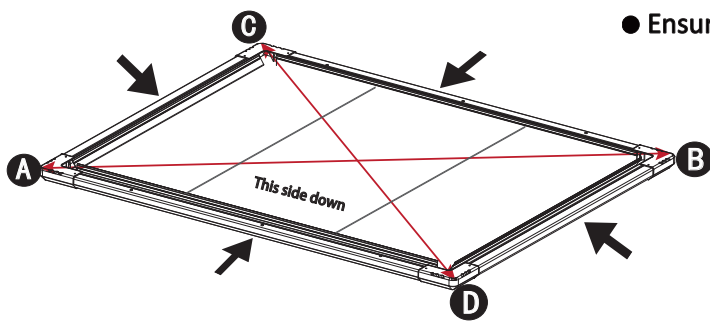
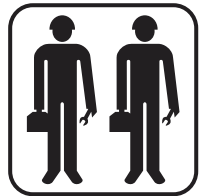
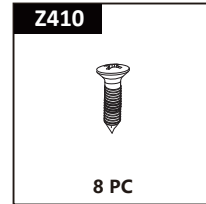

● Ensure AB equal to CD before nailing.

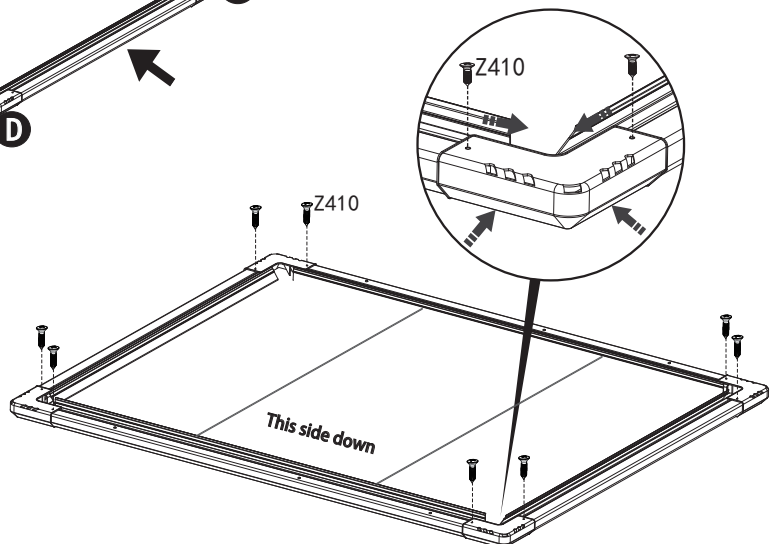

Step 42

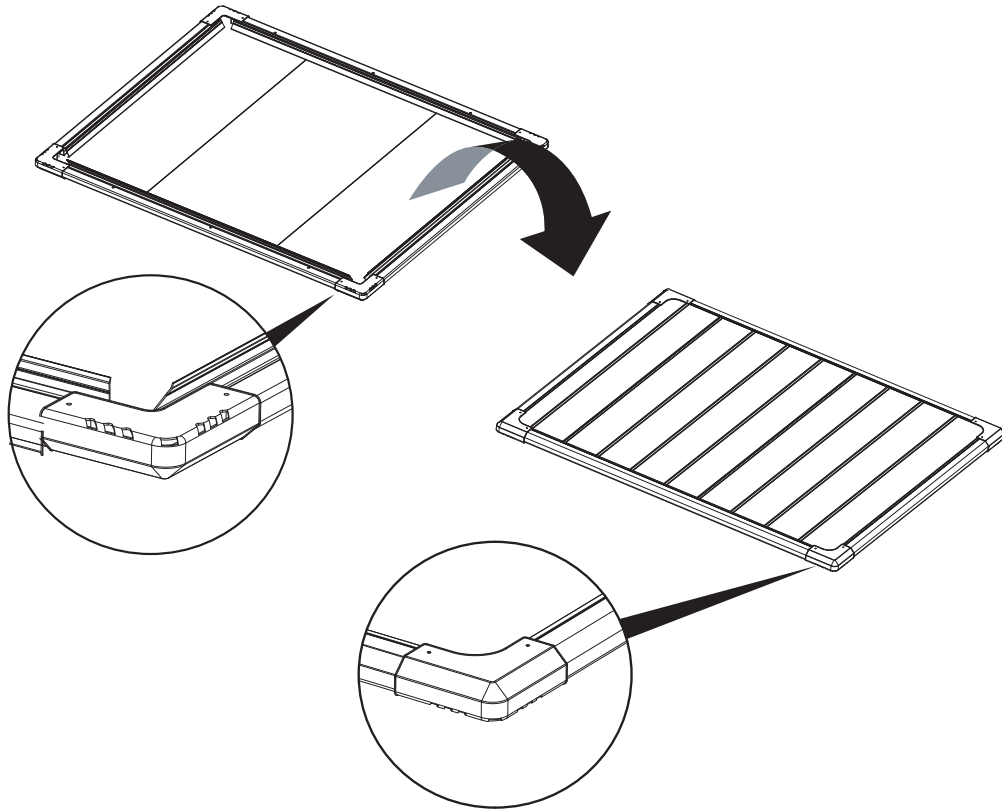

Step 43

Caution:
Please use Drill  to predrill
a hole at depth 1mm before screw.

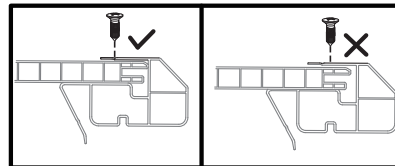

● Nail along the marked line on profile.

Z420



18 PC

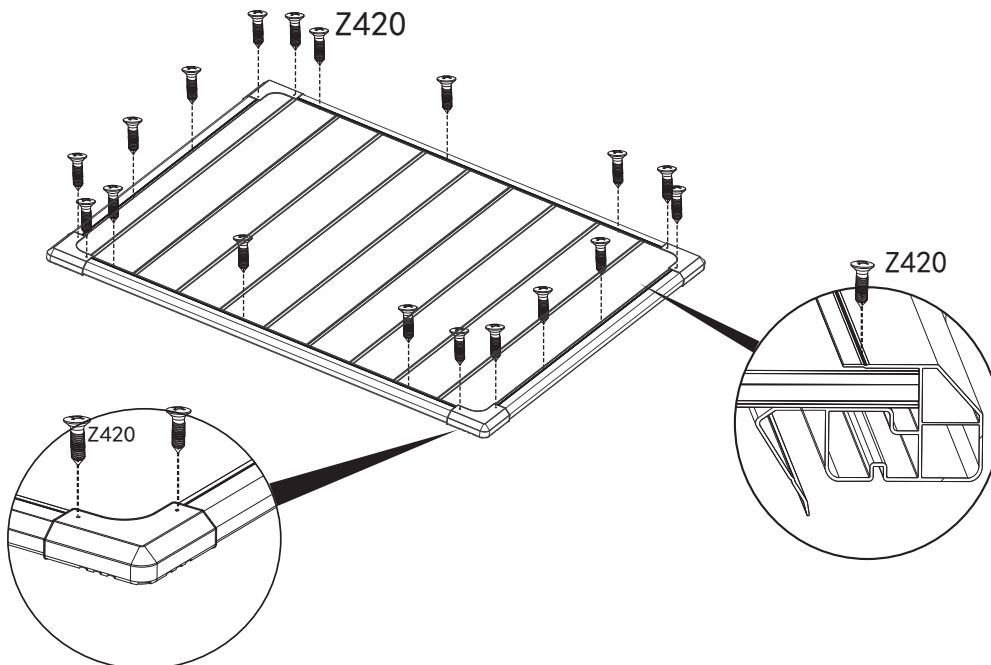

Step 44

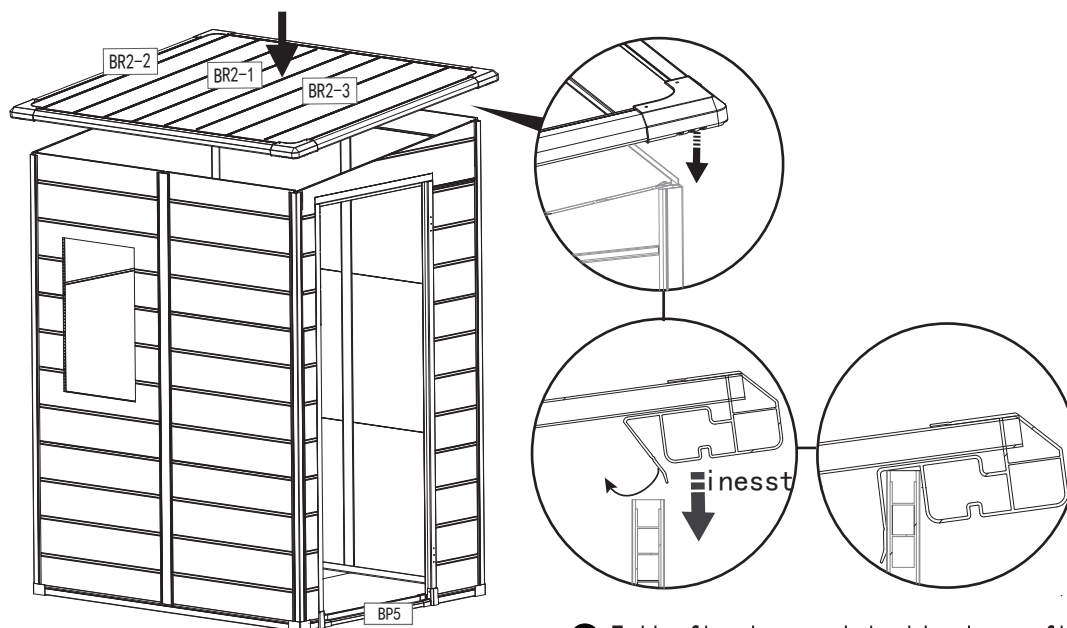
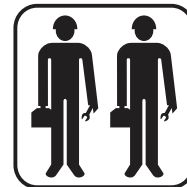

- Fully fit the panel inside the profile

Step 45

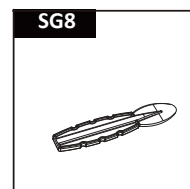

- Ensure fully fit the panels inside the profiles of the roof, using the spatula according to the following picture.

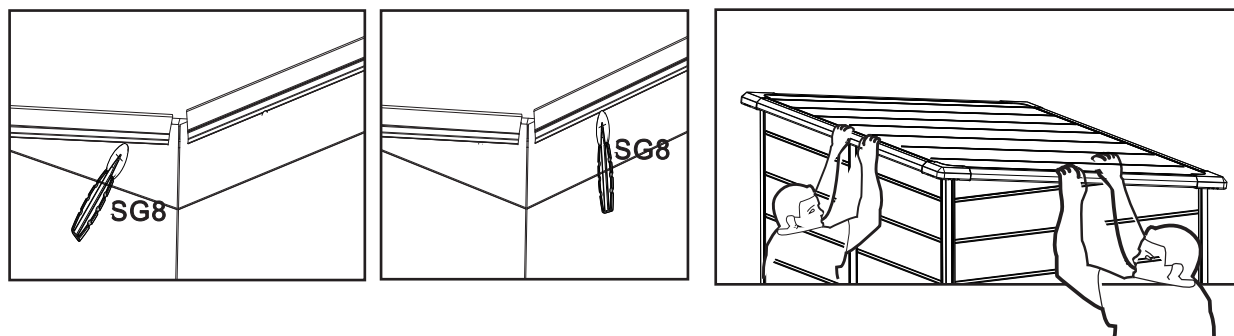

Step 46

Caution:
Please use Drill  to predrill
a hole at depth 1mm before screw.



Z420



14 PC

• Please note the nailing direction.

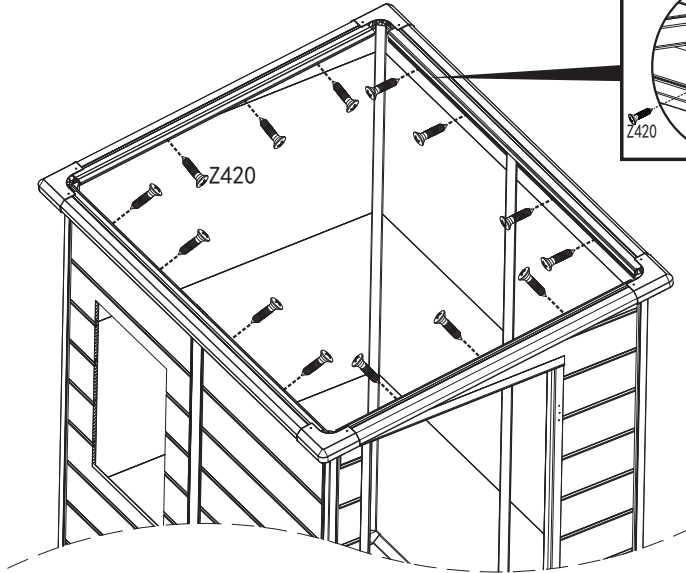
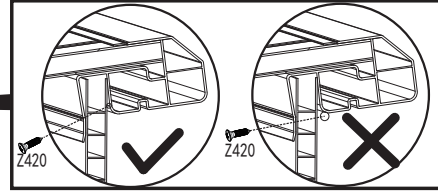

Step 47

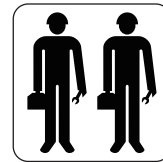

SG10

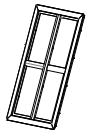

1 PC

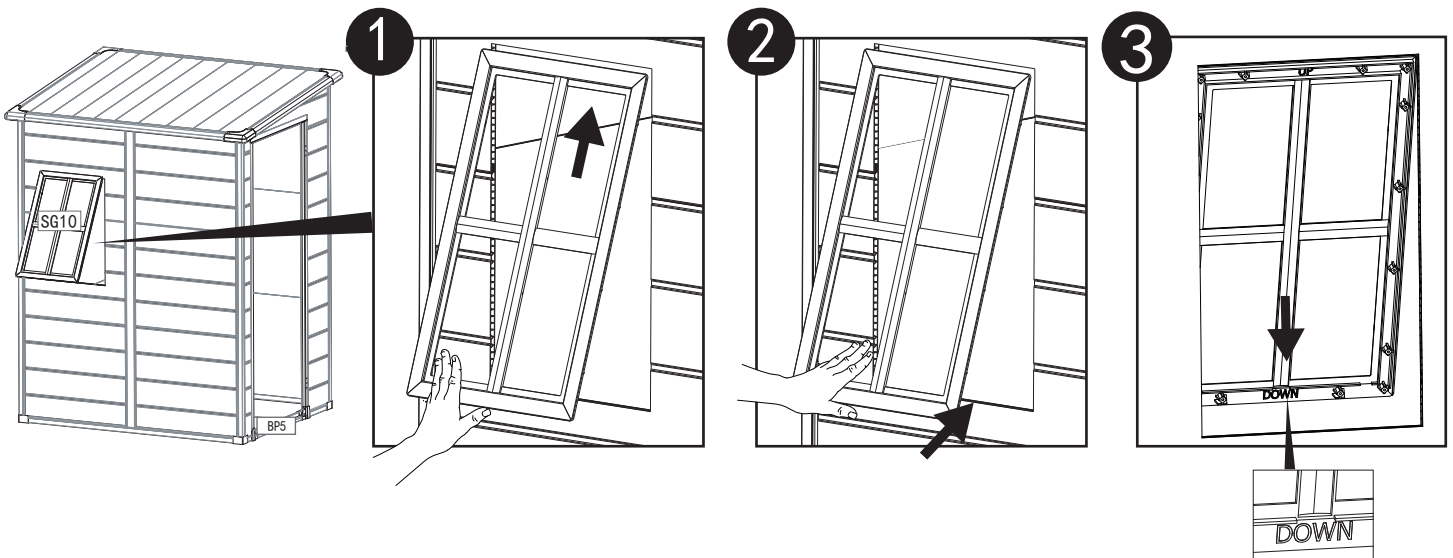

Step 48

- Remove the film before fixing SG101

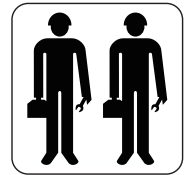
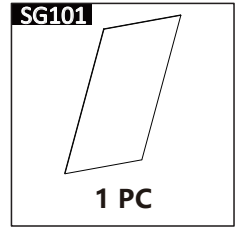
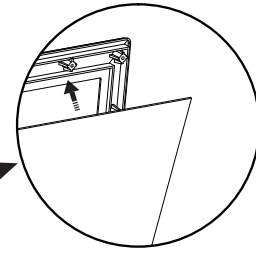
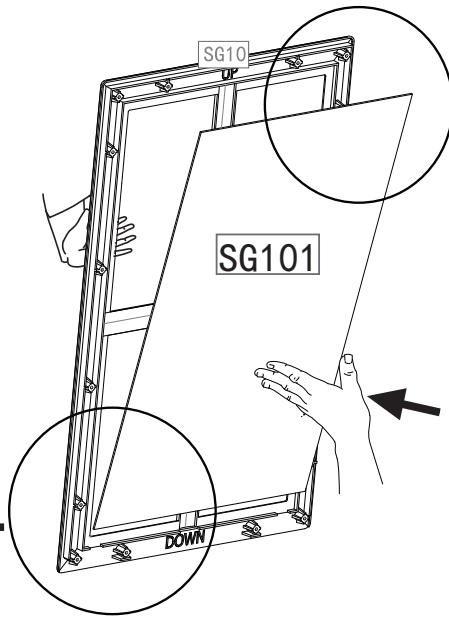
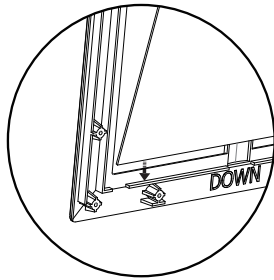
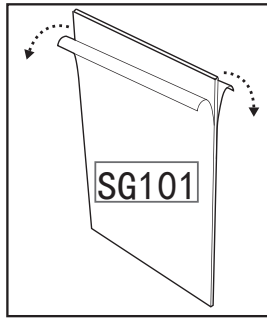

- Need two persons to fix SG101, one person presses it, and the other person assembles it.

Step 49

The press plate boss section shall be pressed against SG101

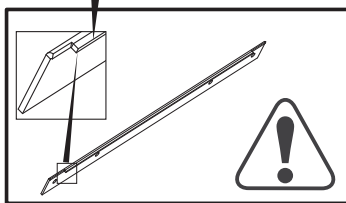

- Press tightly to avoid falling down
- Please note the side with bending edge be pressed to SG101
- It's better to fix just one screw on each SG102&SG103 before each one adjust into right location.

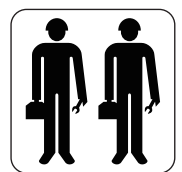
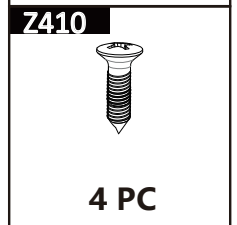
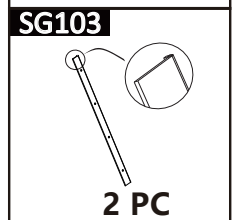
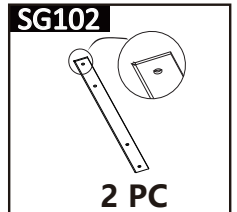
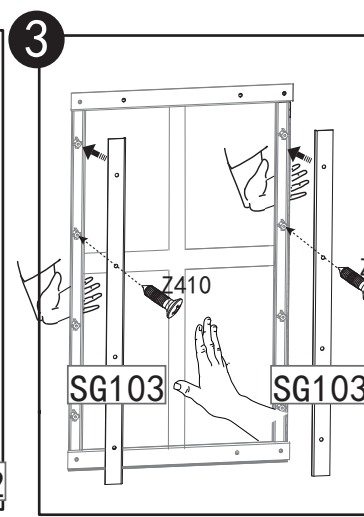
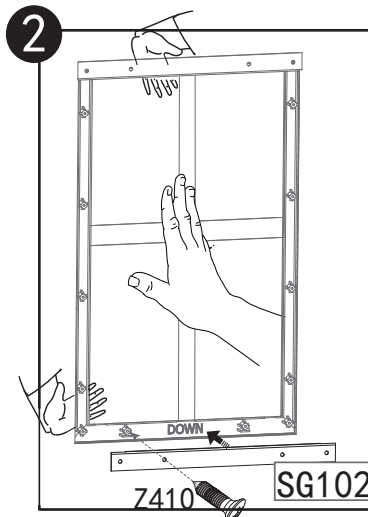
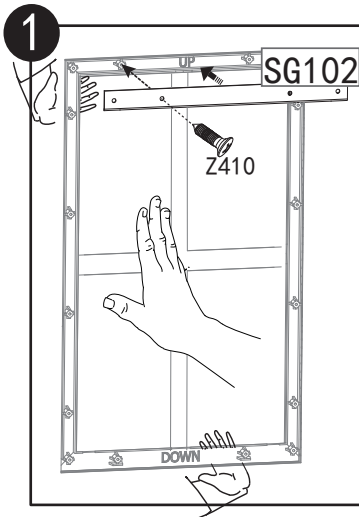

Step 50

Z410



12PC

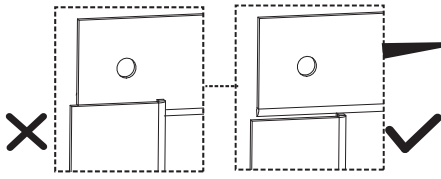

non-interference.

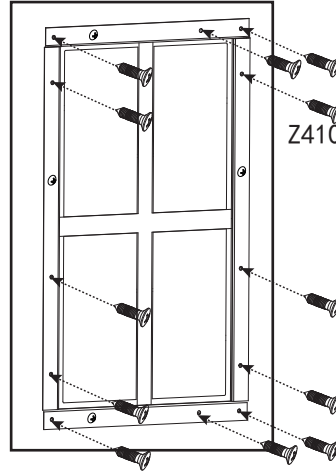
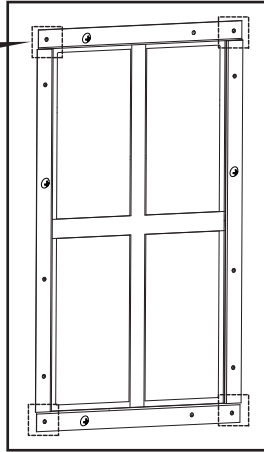

● Adjust SG102&SG103 in right location, then fix all screws

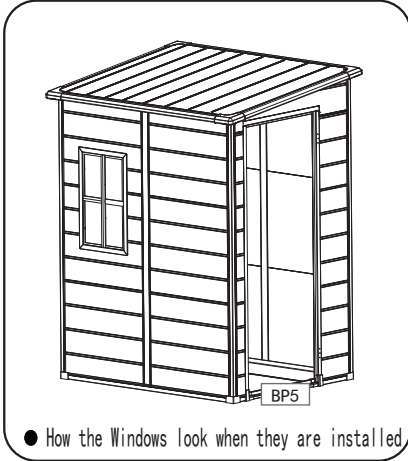

● How the Windows look when they are installed

DOOR SECTION

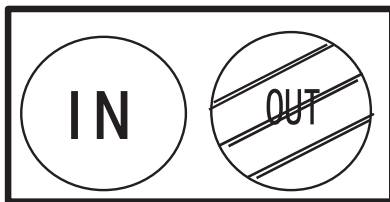

The stripes should be outside

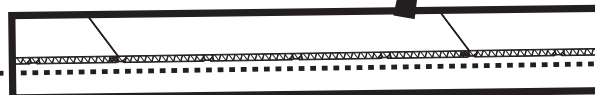
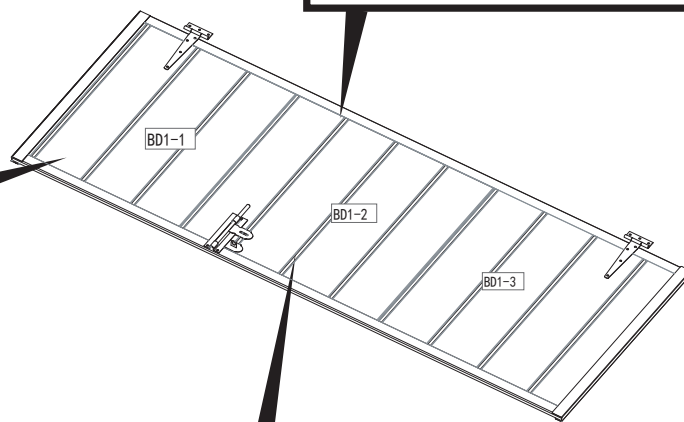

Door mount this is above

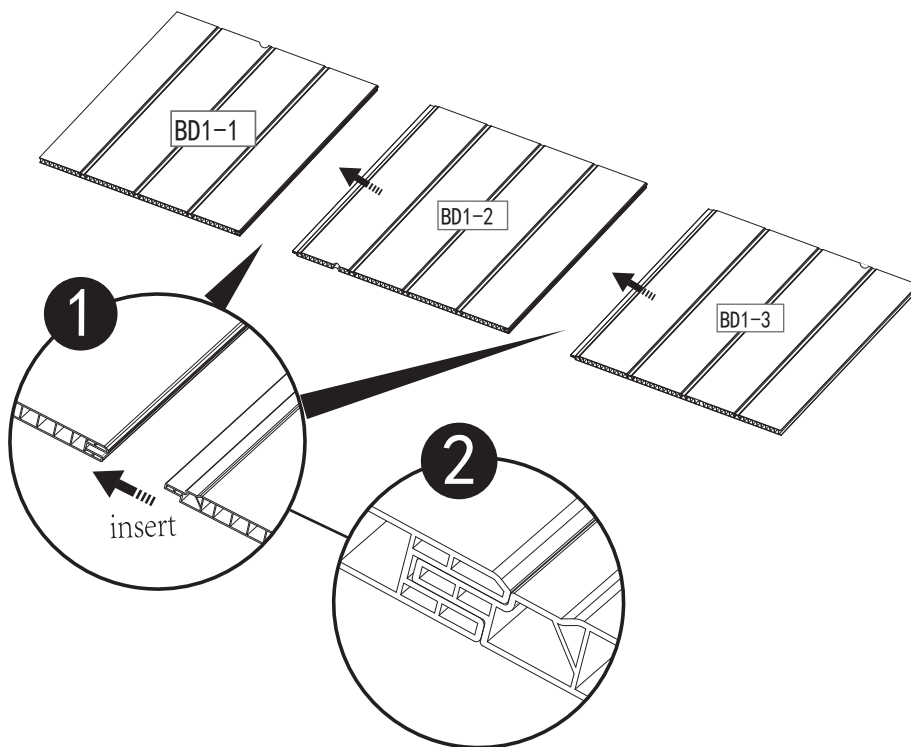
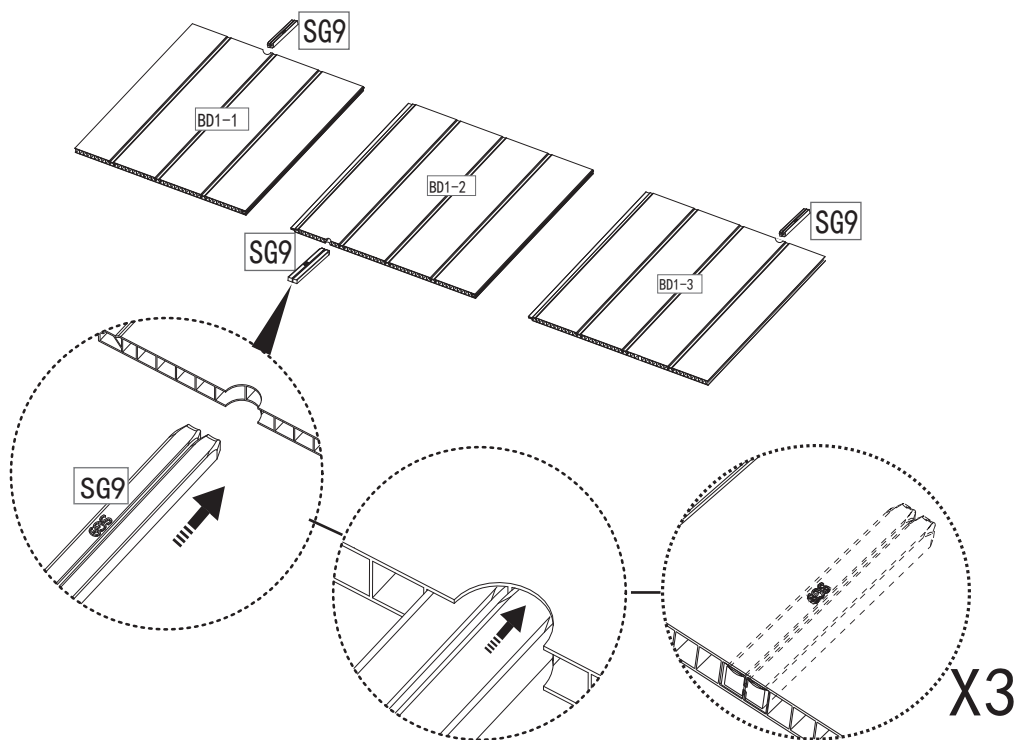

The boards must be straight

Step 51

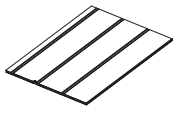
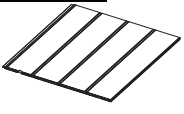
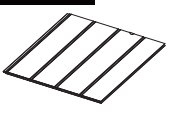

BD1-1	
1 PC	
BD1-2	
1 PC	
BD1-3	
1 PC	
SG9	
3 PC	

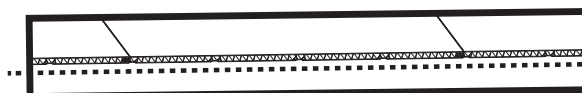

The boards must be straight

Step 52

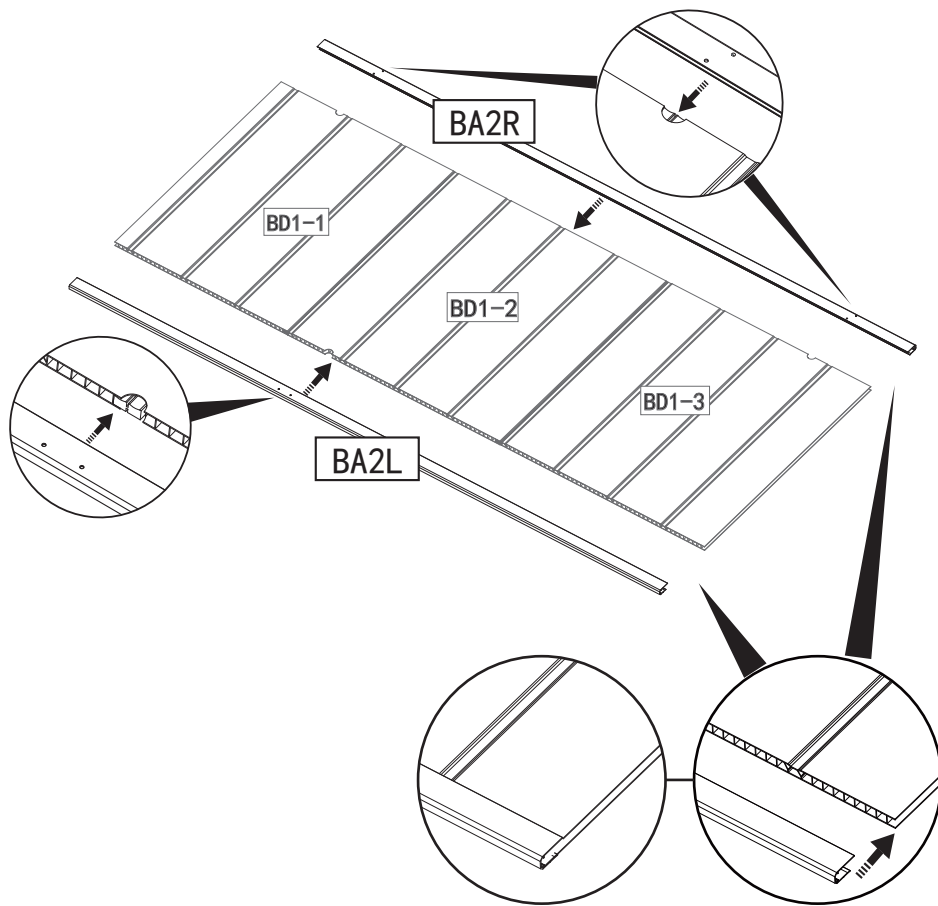

BA2R

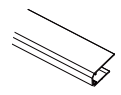

1 PC

BA2L

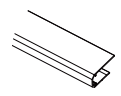

1 PC

SG8



Step 53

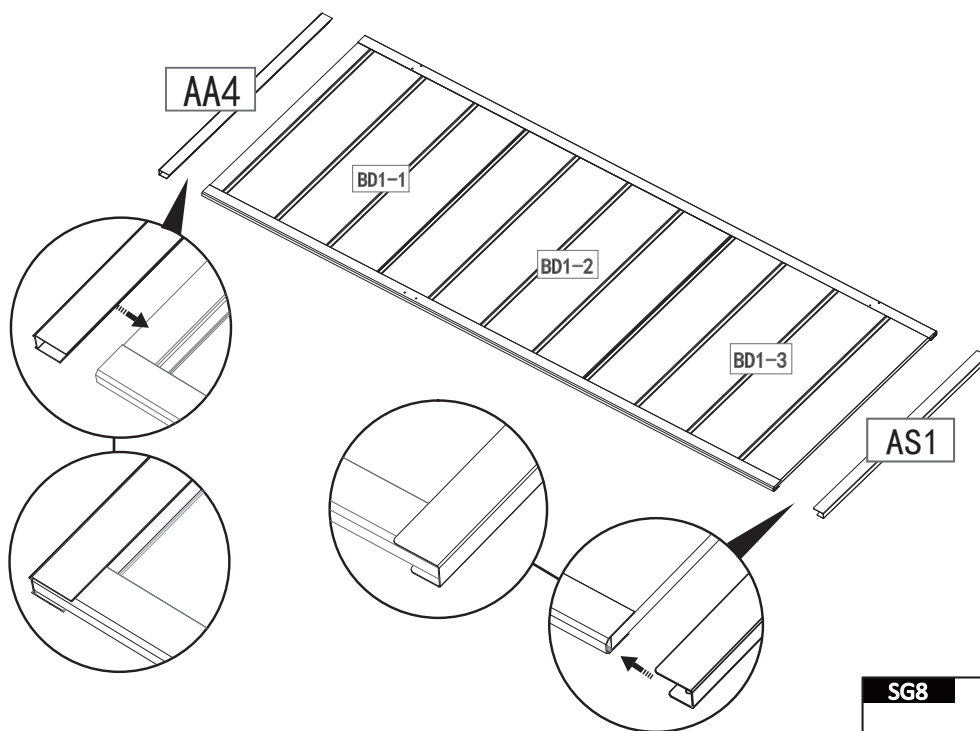

AA4



1 PC

AS1

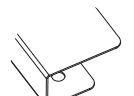

1 PC

SG8



Step 54

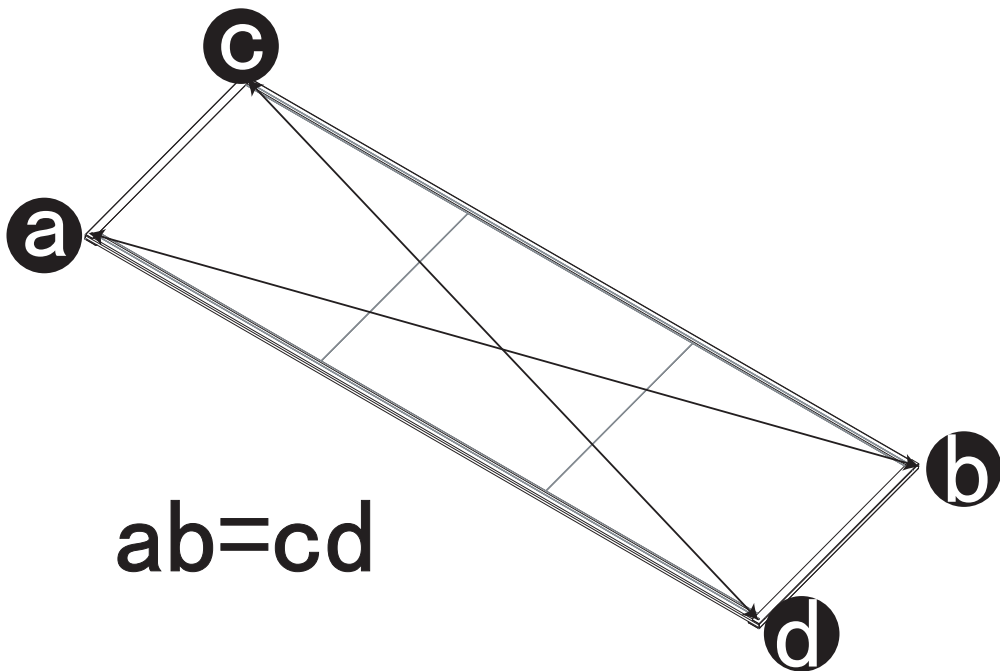
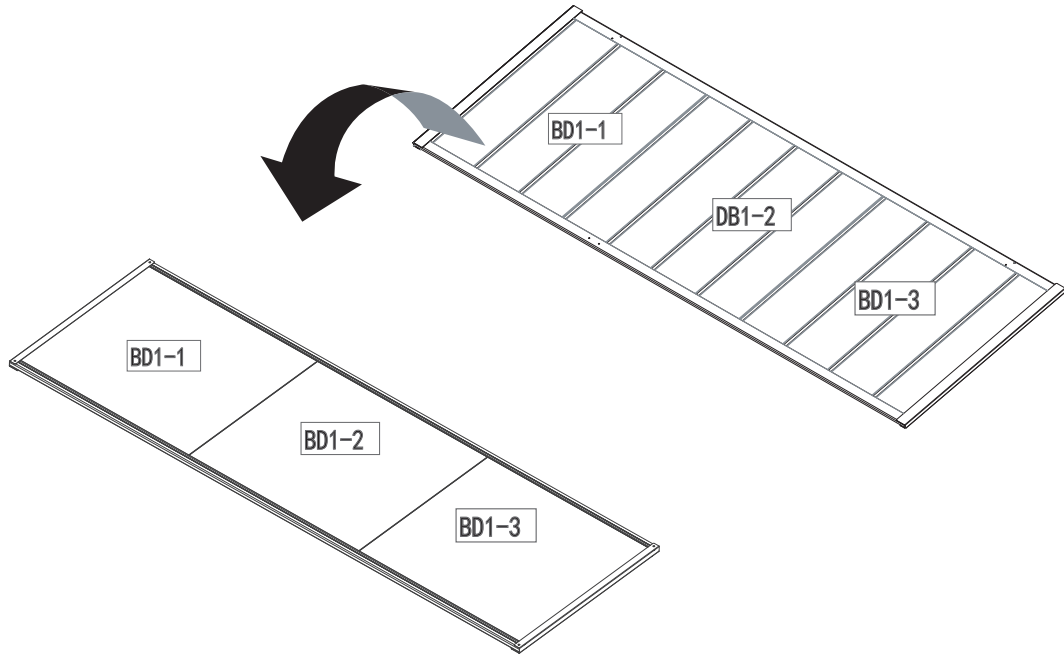

Step 55

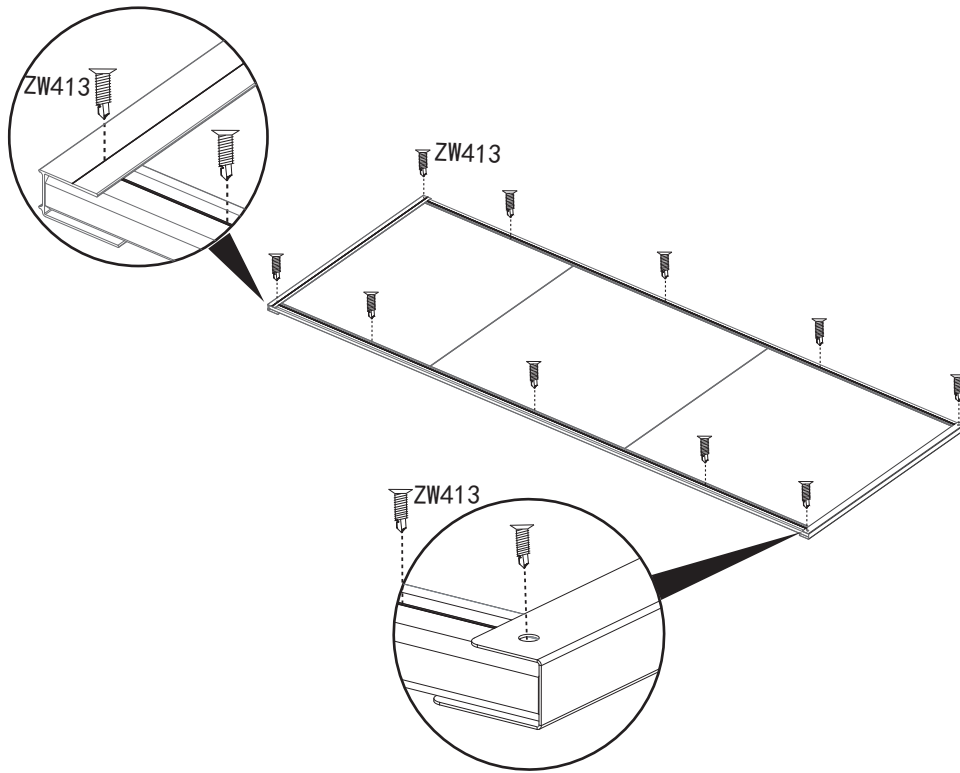

ZW413



10PC

Step 56

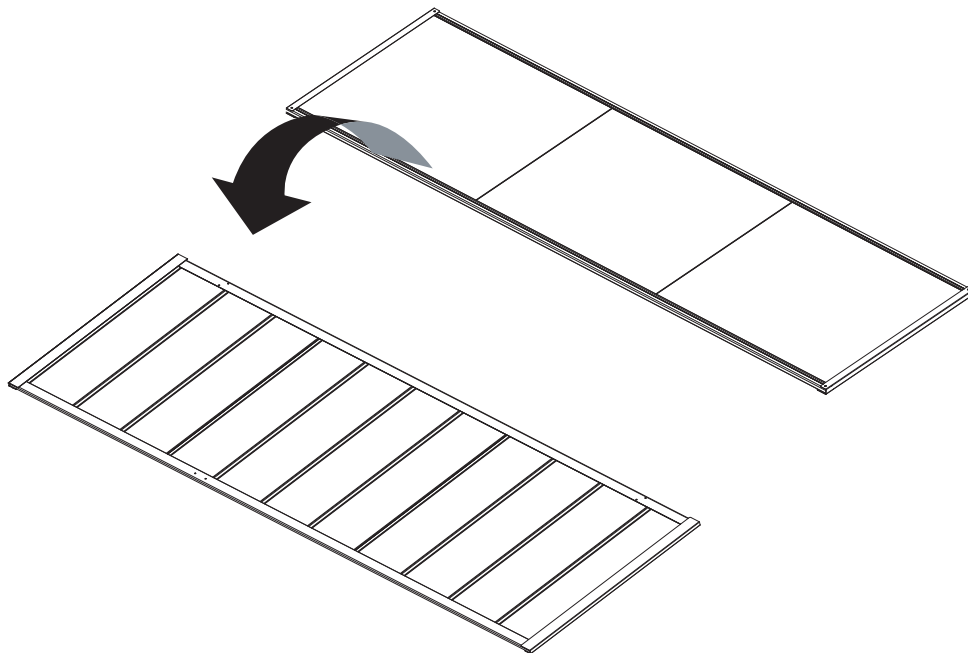

Step 57

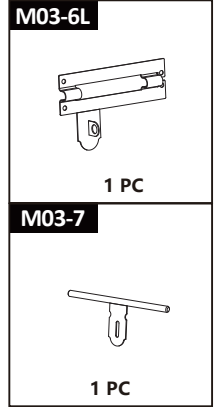
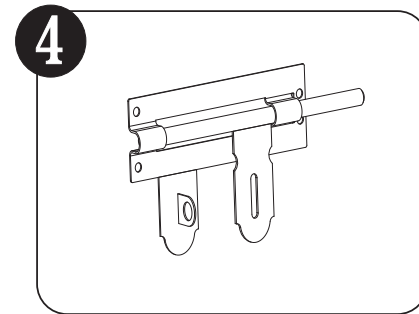
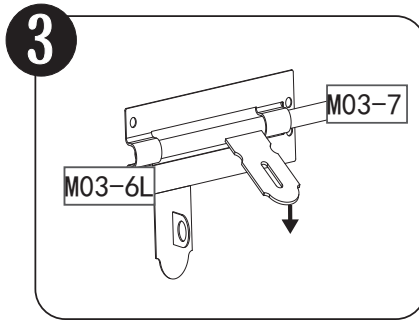
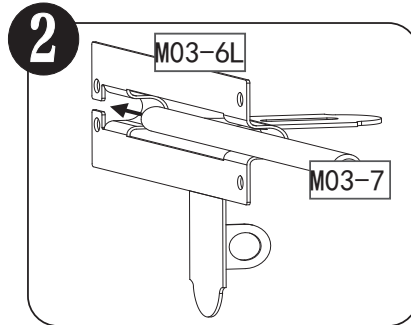
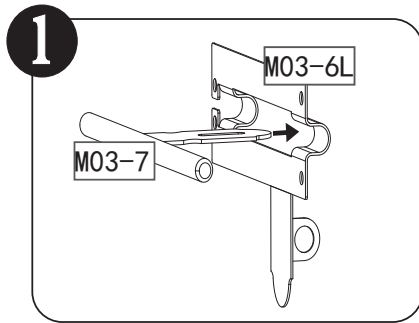

Step 58

Don't fasten the screws in this step, to adjust the positions of doors

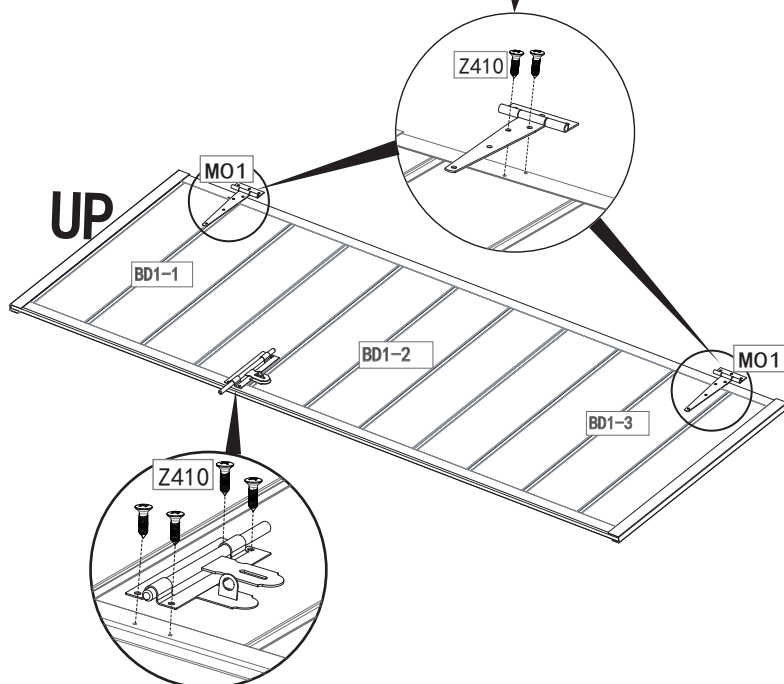

Z410



8 PC

MO1

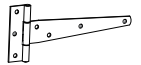

2 PC

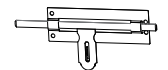

1 PC

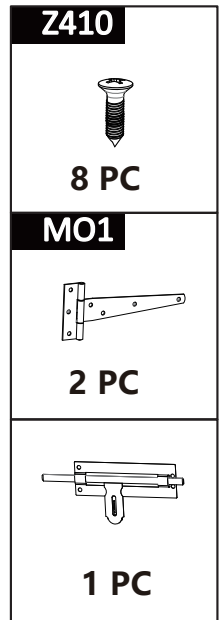

Step 59

Z410

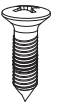

10PC

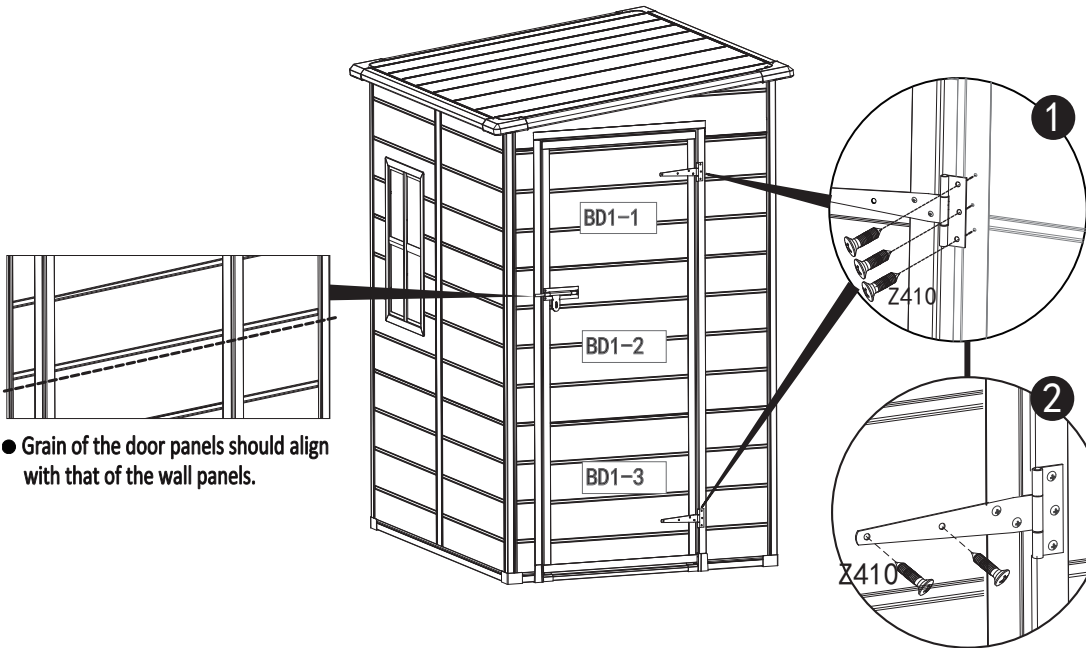

- Grain of the door panels should align with that of the wall panels.

Nail the door after place adjustment and fasten all the screws.

Step 60

ZW413



2 PC

MO4



1 PC

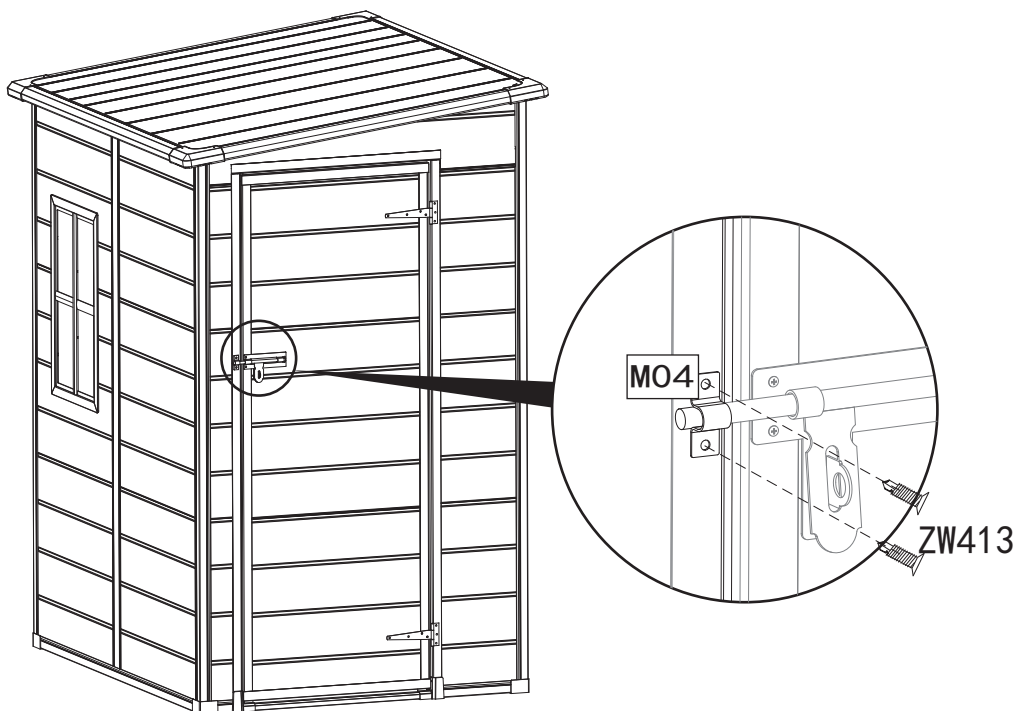

Step 61

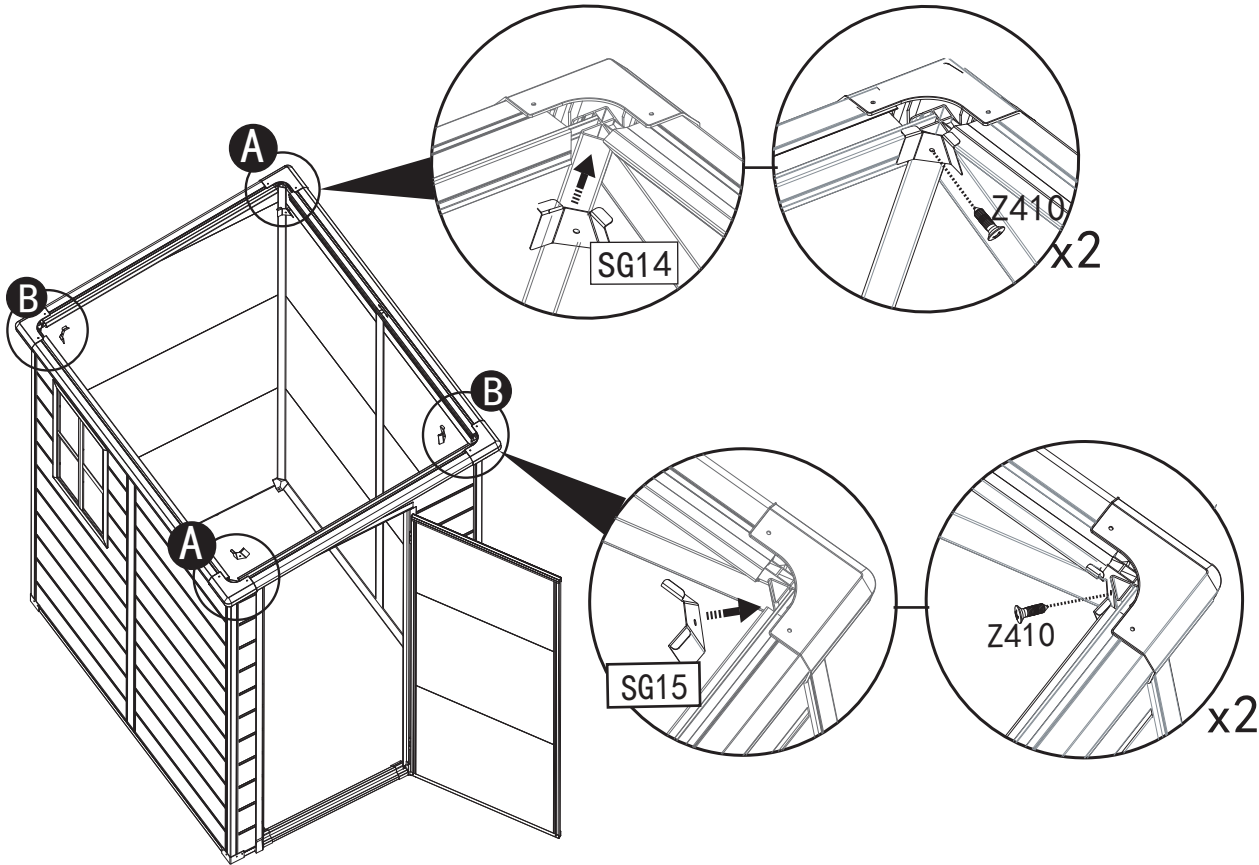

SG14

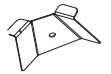

2 PC

SG15



2 PC

Z410



4 PC

Step 62

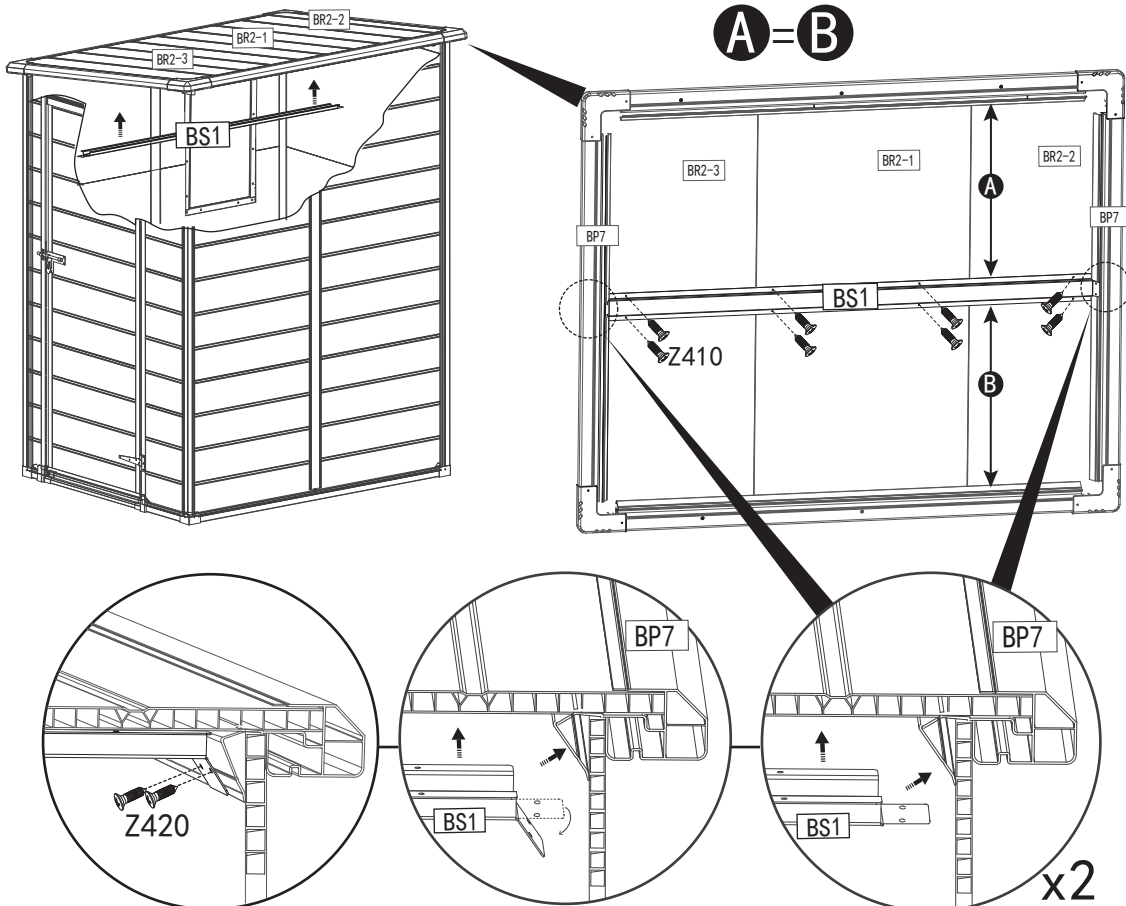

BS1

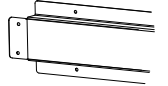

1 PC

Z420



4 PC

Z410



8 PC

PARTS SCHEMATIC

ROOF PARTS

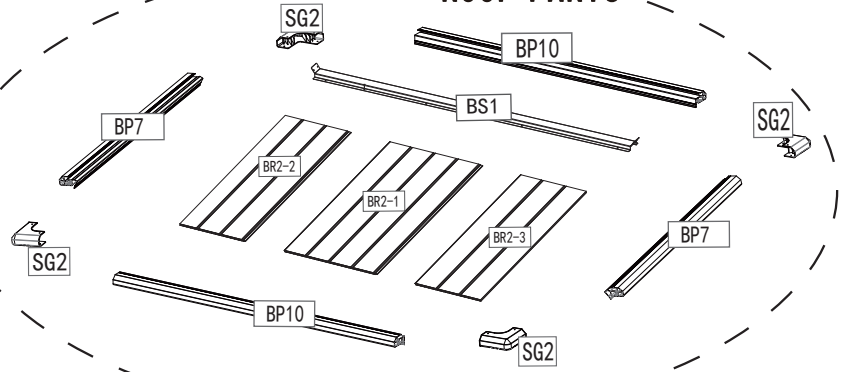

Rear side

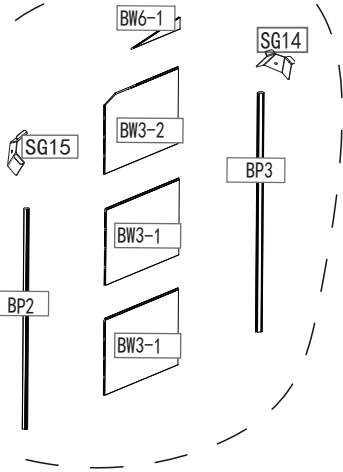

Right

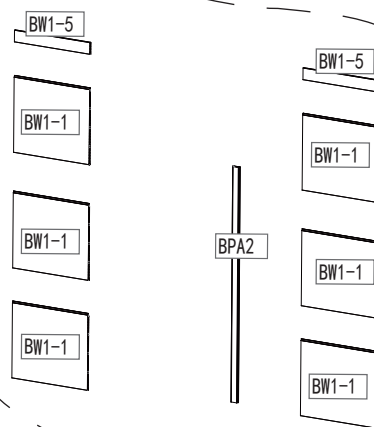

Left

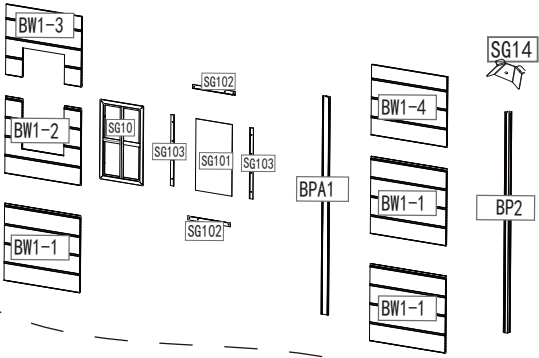

Front

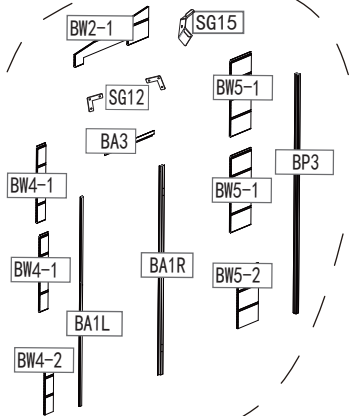

DOOR PARTS

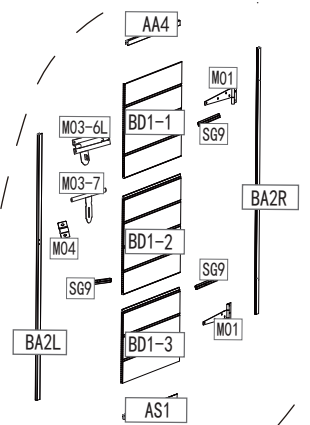

FLOOR PARTS

