

Using Camlocks

Step 1

Connect the male camlock as directed in the assembly instructions using a screwdriver.

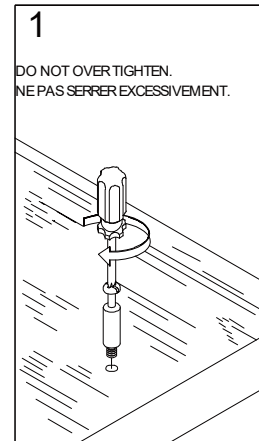

Step 2

Push the male camlock into the entry hole.

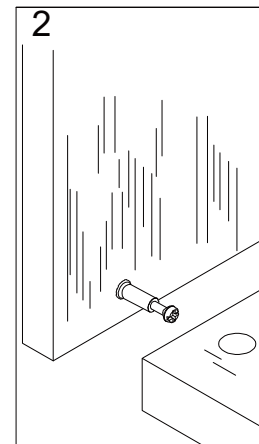

Step 3

Insert the female camlock as shown in the instruction.

Note: ensure that the arrow on the top of the camlock points towards the entry hole for the male camlock.

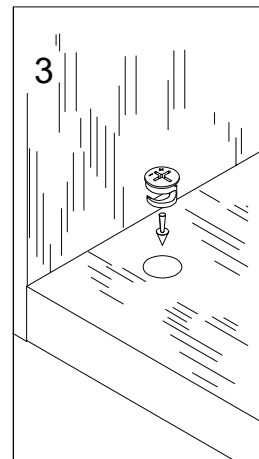

Step 4

Turn the female camlock clockwise with a screwdriver.

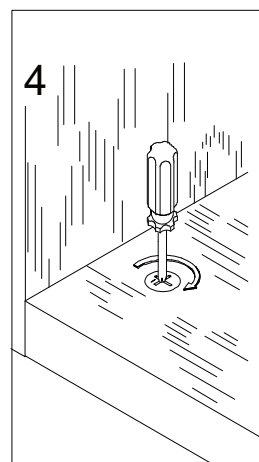

You should feel a click when the camlock is locked in place.

The joint is now secure.

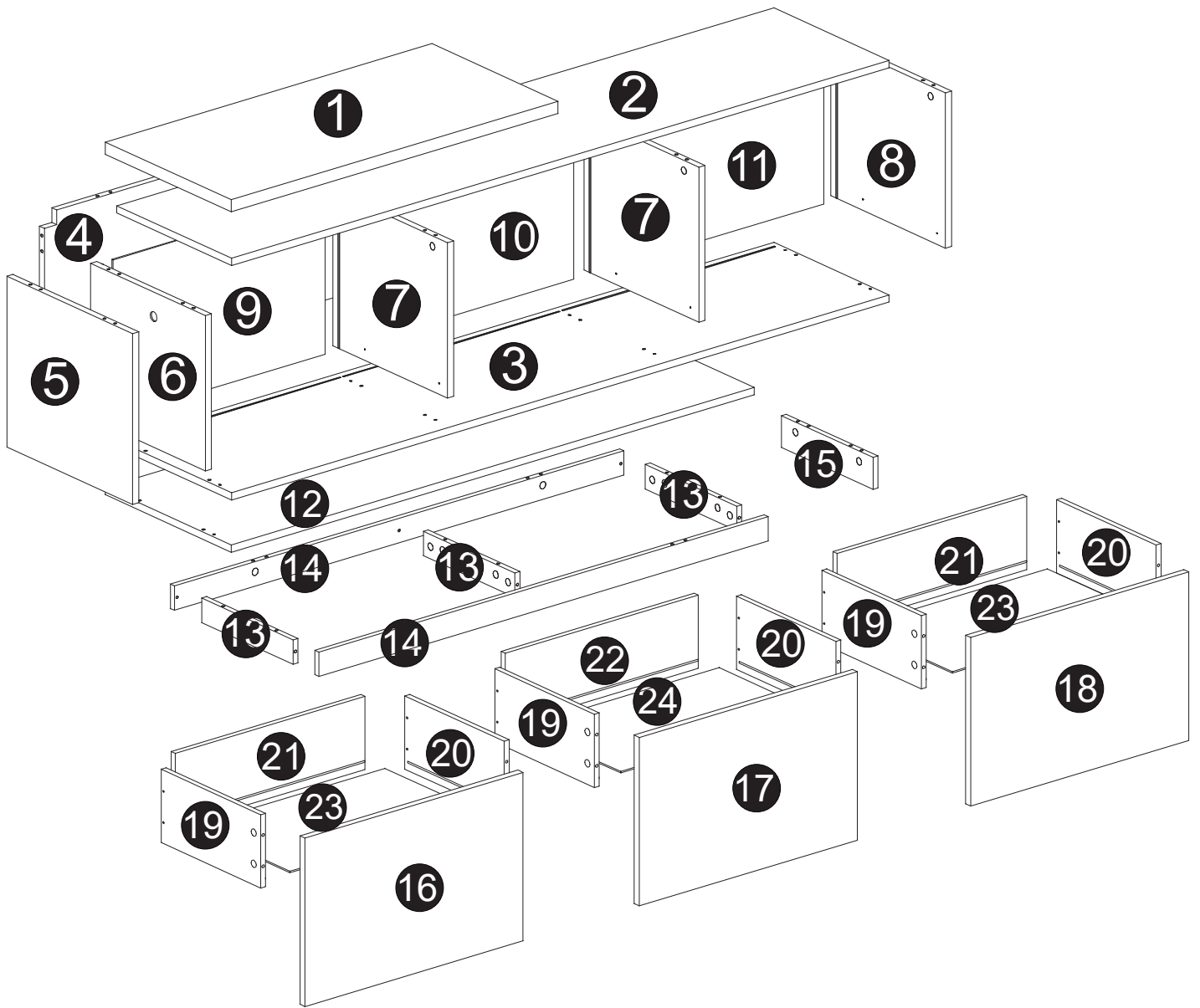

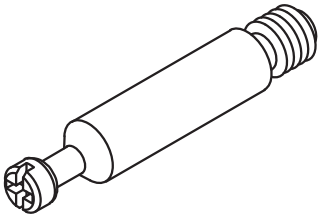
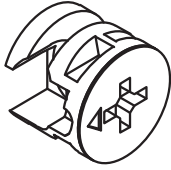
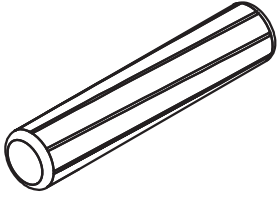

Parts List (EN) / Teile Liste (DE)

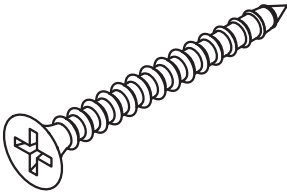
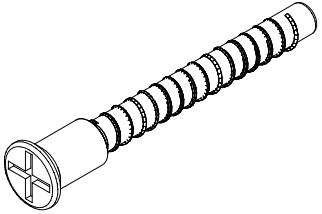
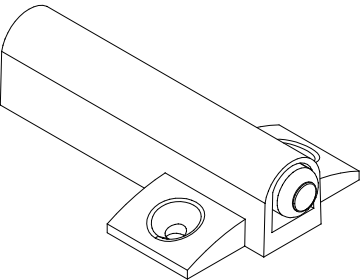
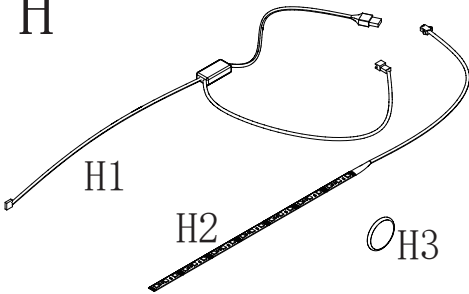
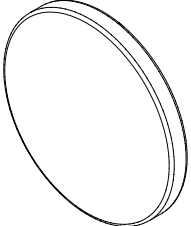
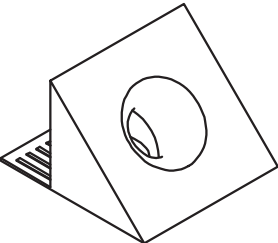
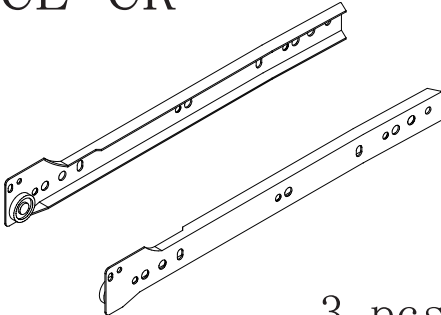
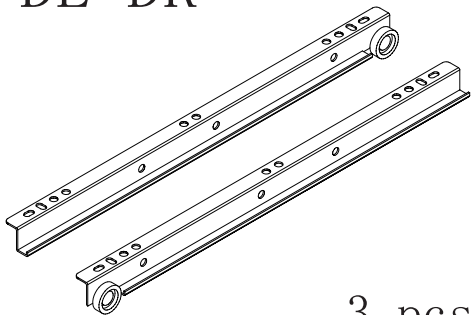
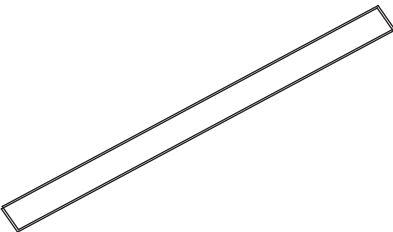
<p>A</p>  <p>$\Phi 6 \times 28 \text{MM}$ 44 pcs</p>	<p>B</p>  <p>$\Phi 15 \times 9 \text{MM}$ 44 pcs</p>	<p>C</p>  <p>$\Phi 6 \times 30 \text{MM}$ 32 pcs</p>
<p>D</p>  <p>$\Phi 3.5 \times 12 \text{MM}$ 42 pcs</p>	<p>E</p>  <p>$\Phi 3.5 \times 35 \text{MM}$ 12 pcs</p>	<p>F</p>  <p>$\Phi 5 \times 40 \text{MM}$ 12 pcs</p>
<p>G</p>  <p>3 pcs</p>	<p>H</p>  <p>1 pcs</p>	<p>J</p>  <p>2 pcs</p>
<p>K</p>  <p>12 pcs</p>	<p>CL CR</p>  <p>3 pcs</p>	<p>DL DR</p>  <p>3 pcs</p>
<p>L</p>  <p>1 pcs</p>		

Assembly (EN) /Montageschritte (DE)

STEP 1

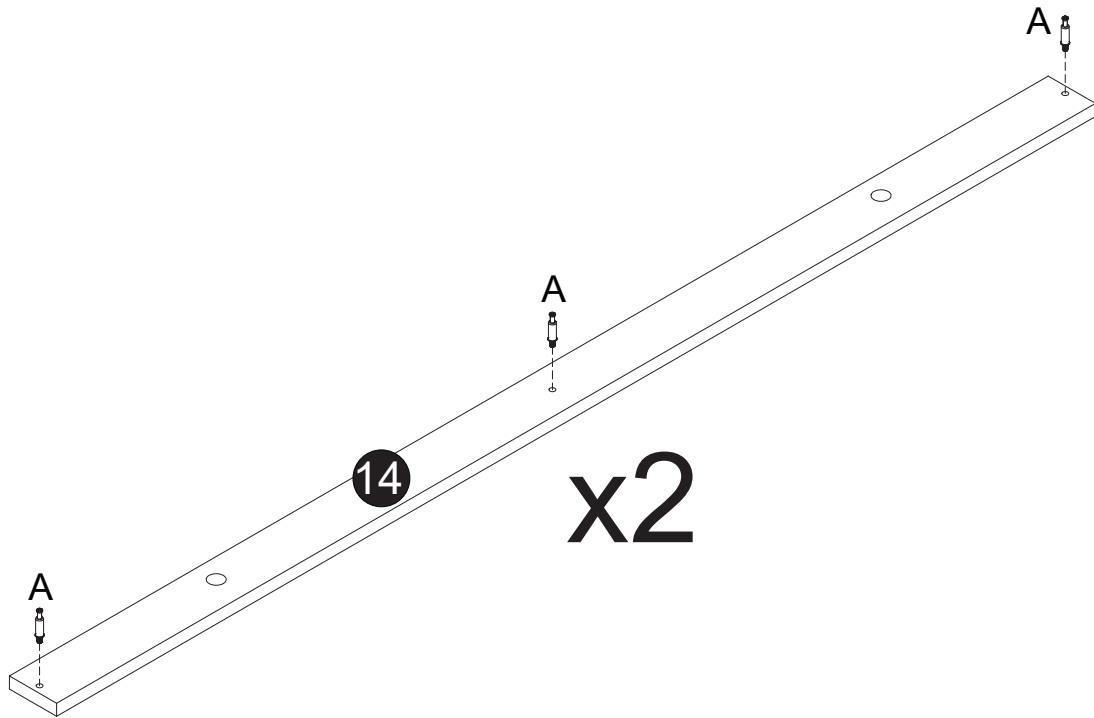
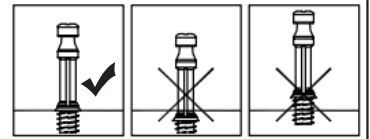

STEP 2

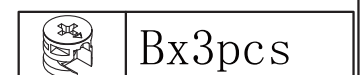
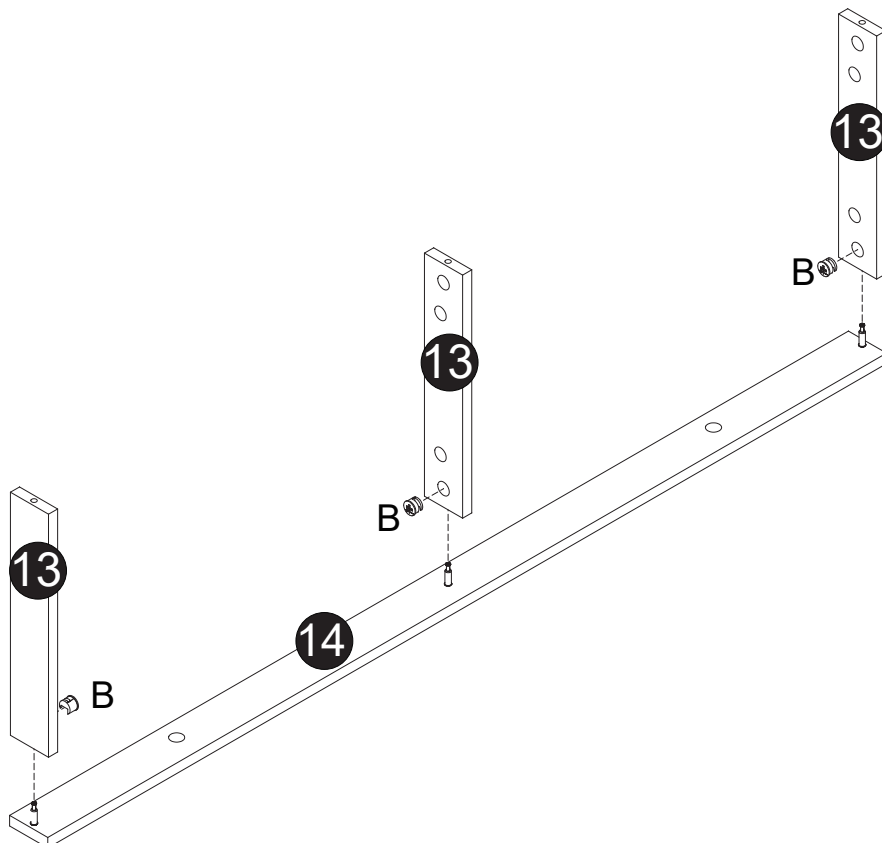
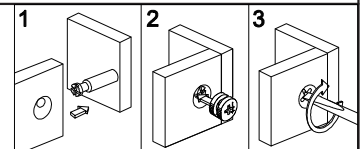

Assembly (EN) /Montageschritte (DE)

STEP 3

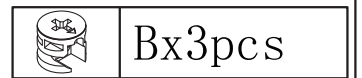
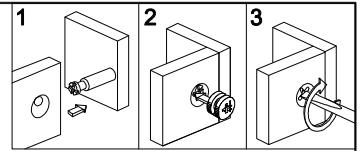
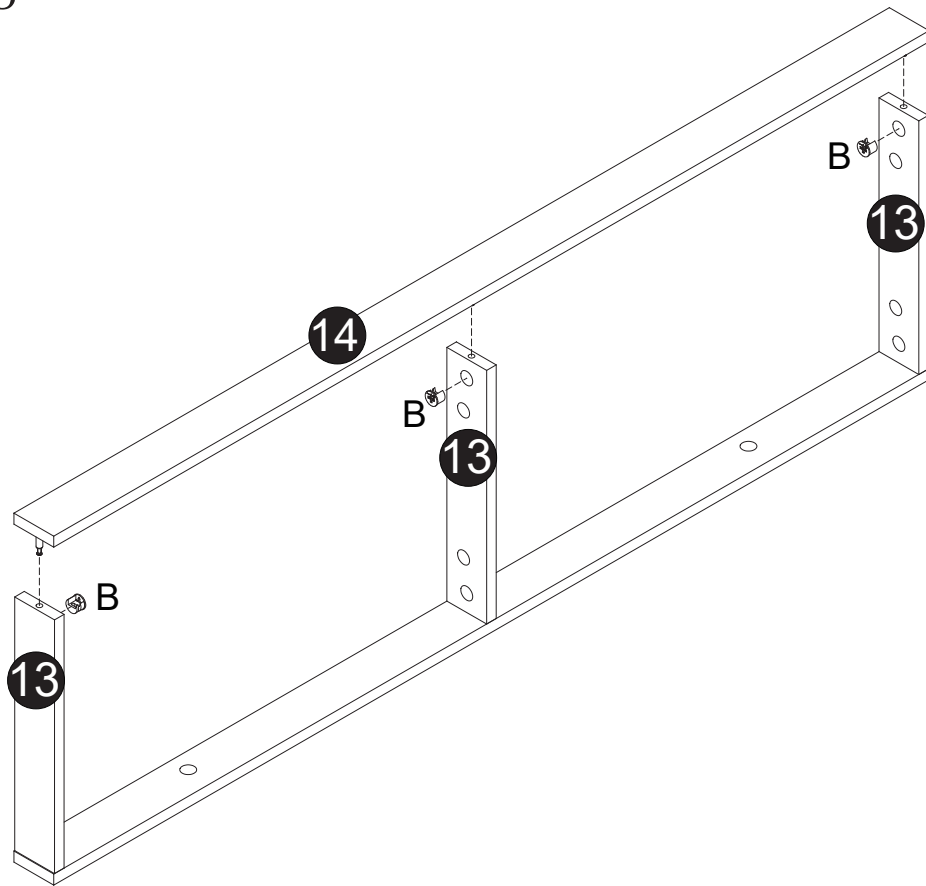

STEP 4

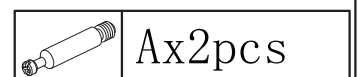
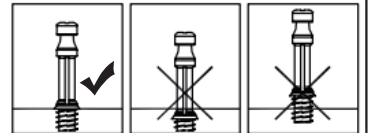
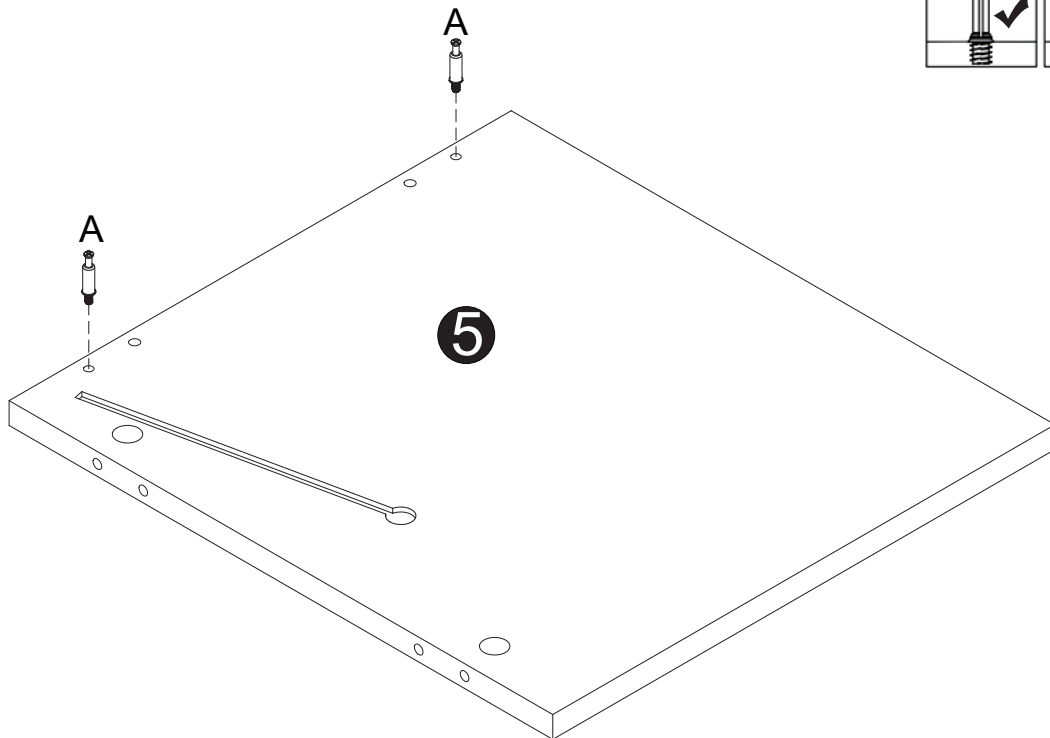

Assembly (EN) /Montageschritte (DE)

STEP 5

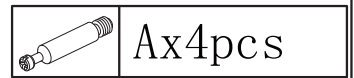
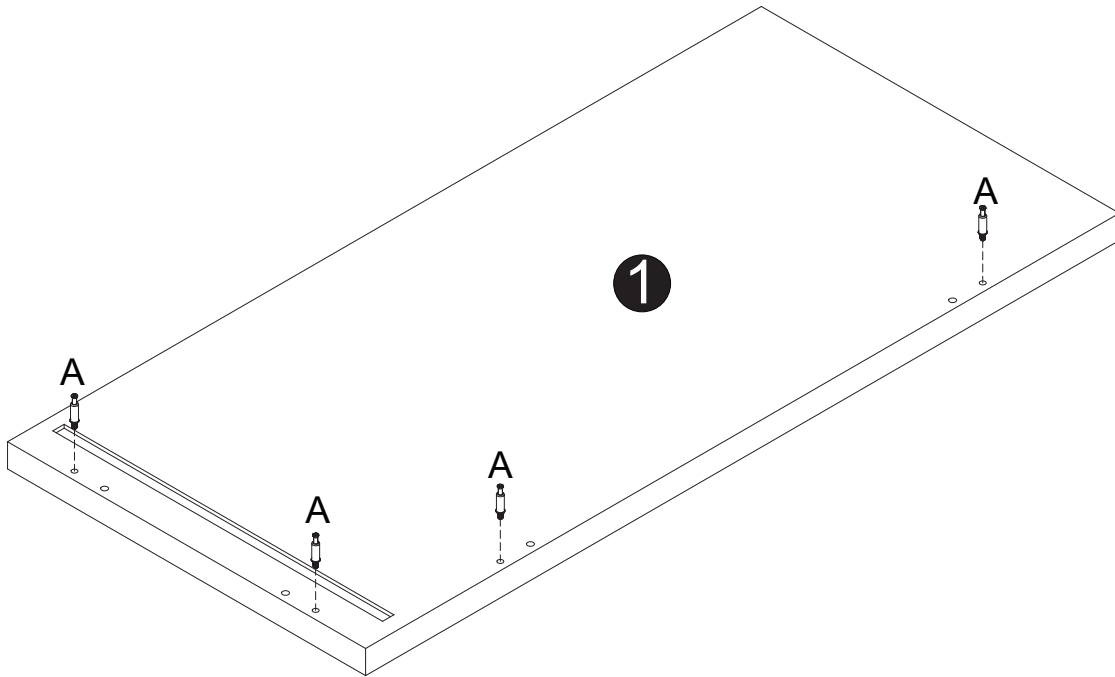
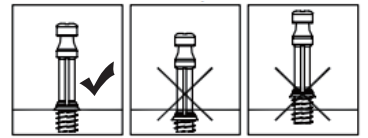

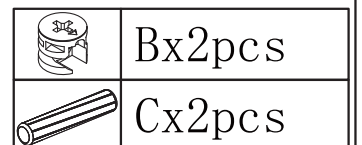
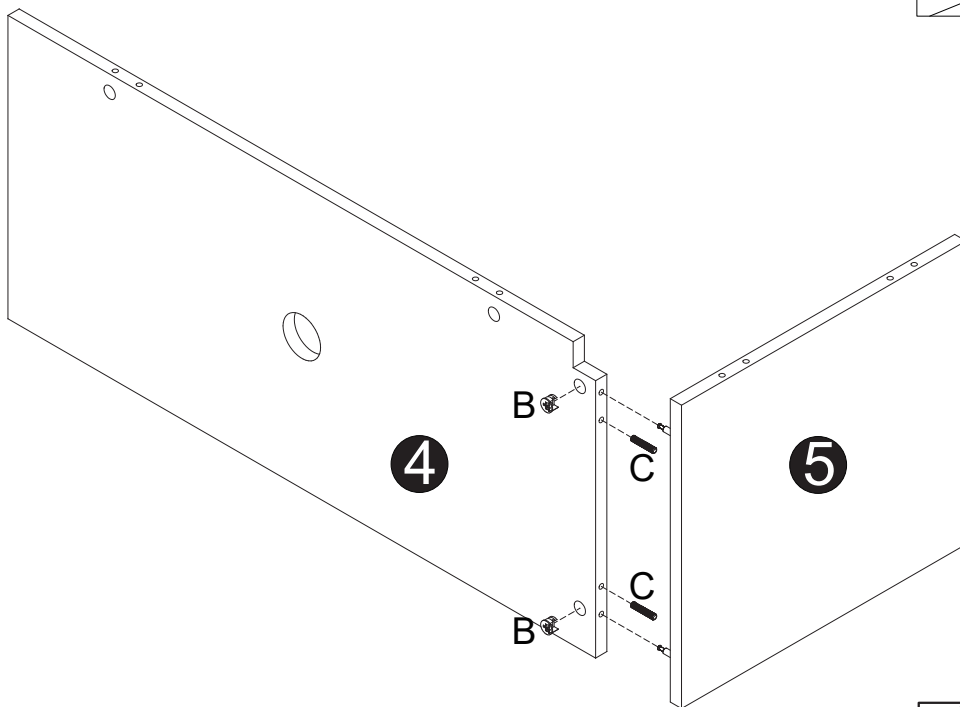
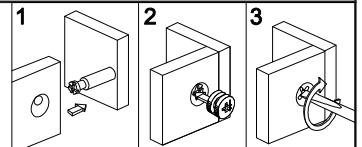

STEP 6

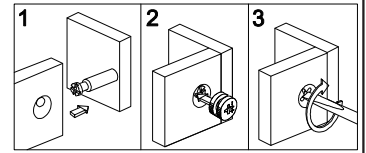
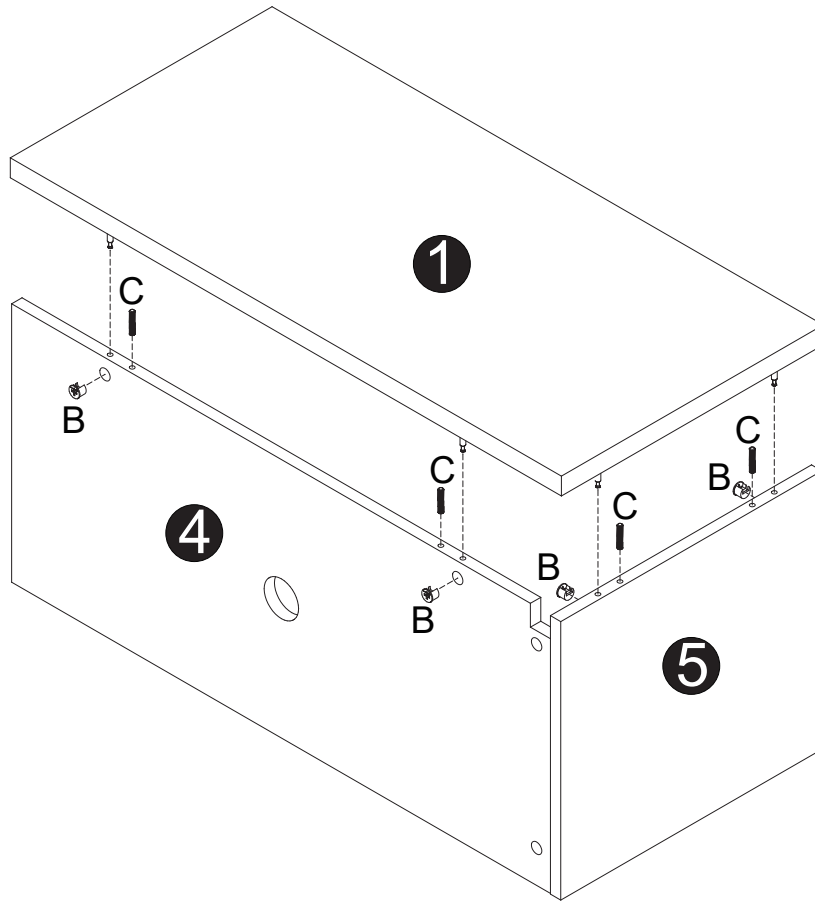

Assembly (EN) /Montageschritte (DE)

STEP 7



	Bx4pcs
	Cx4pcs

STEP 8

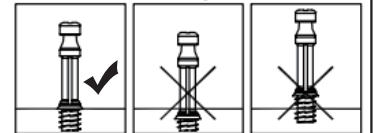
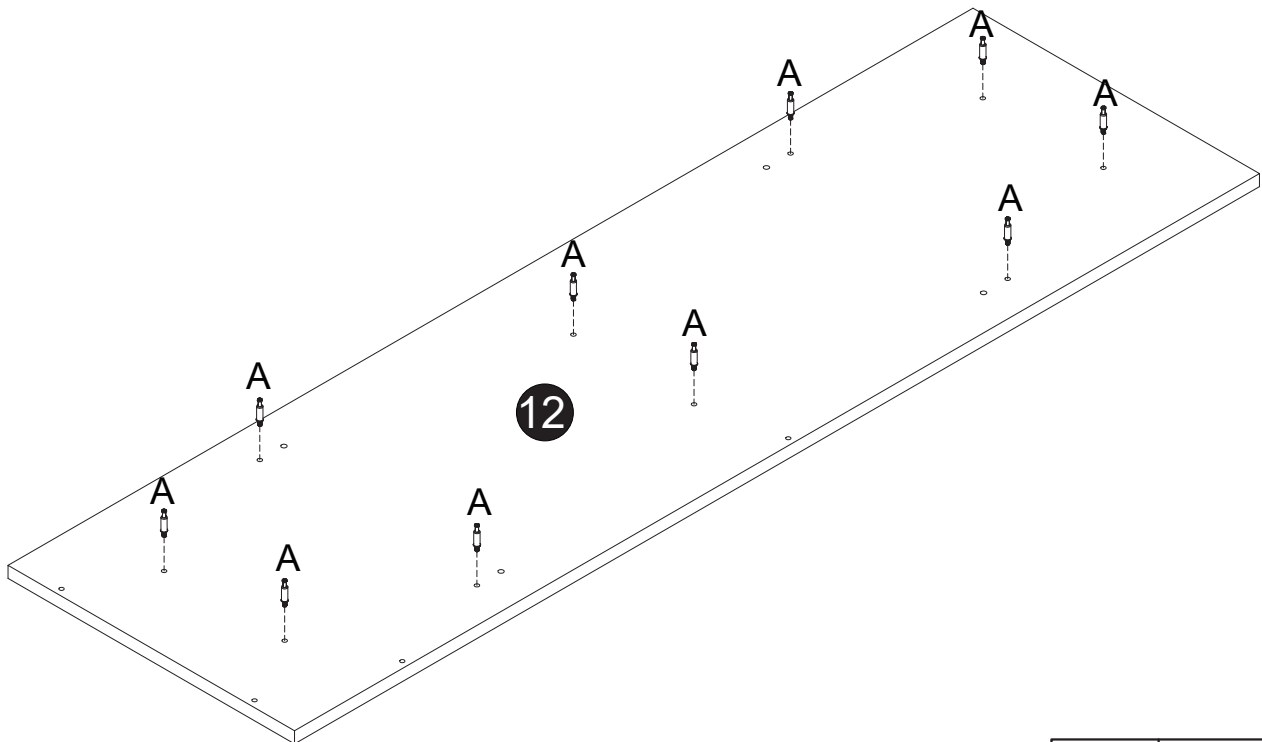



	Ax10pcs
---	---------

Assembly (EN) /Montageschritte (DE)

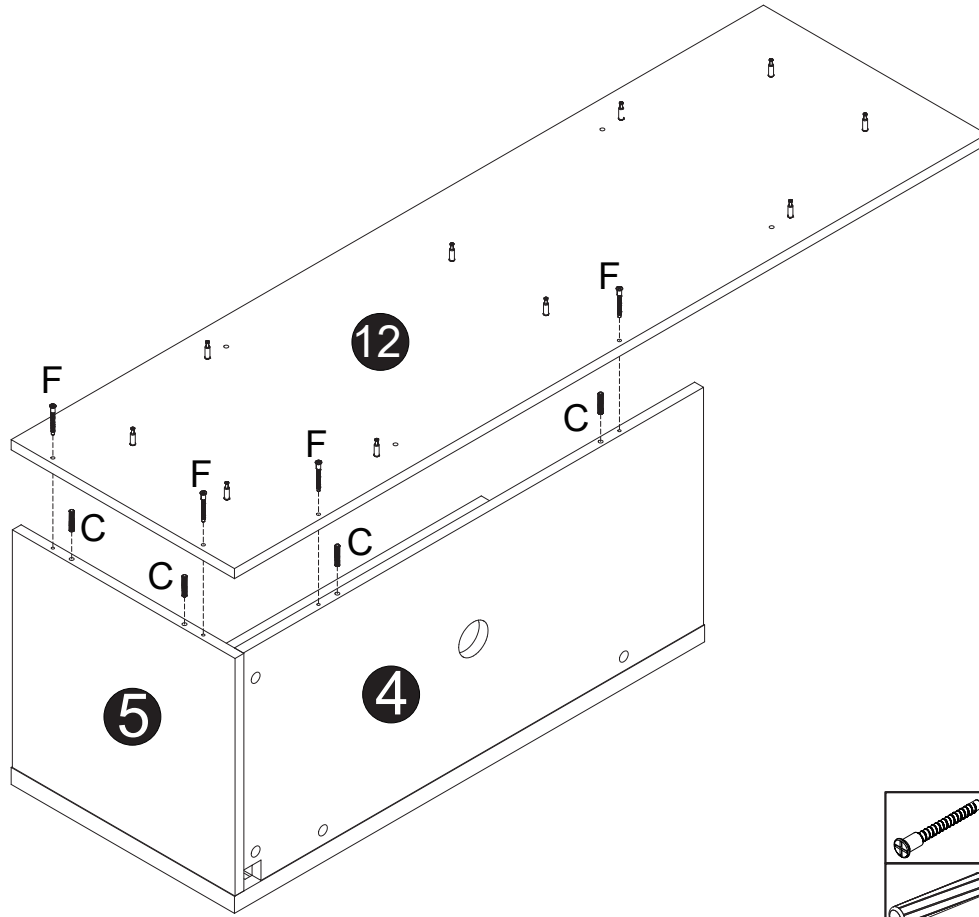

STEP 9

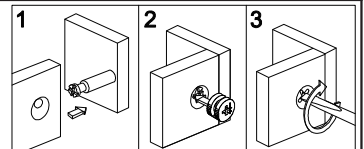
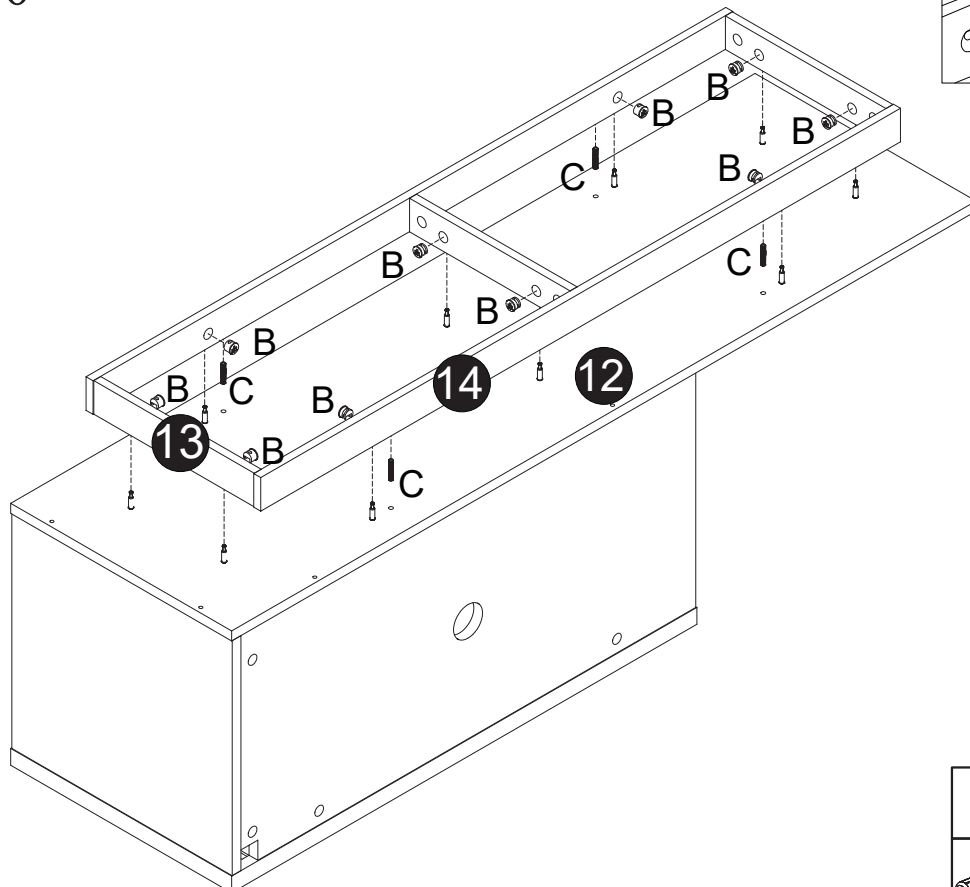

	Fx4pcs
	Cx4pcs

STEP 10



	Bx10pcs
	Cx4pcs

Assembly (EN) /Montageschritte (DE)

STEP 11



Note: CL with a length of 300MM is used here

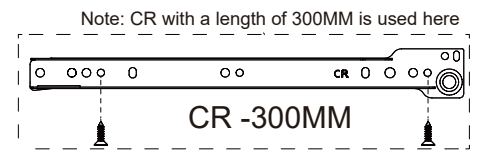
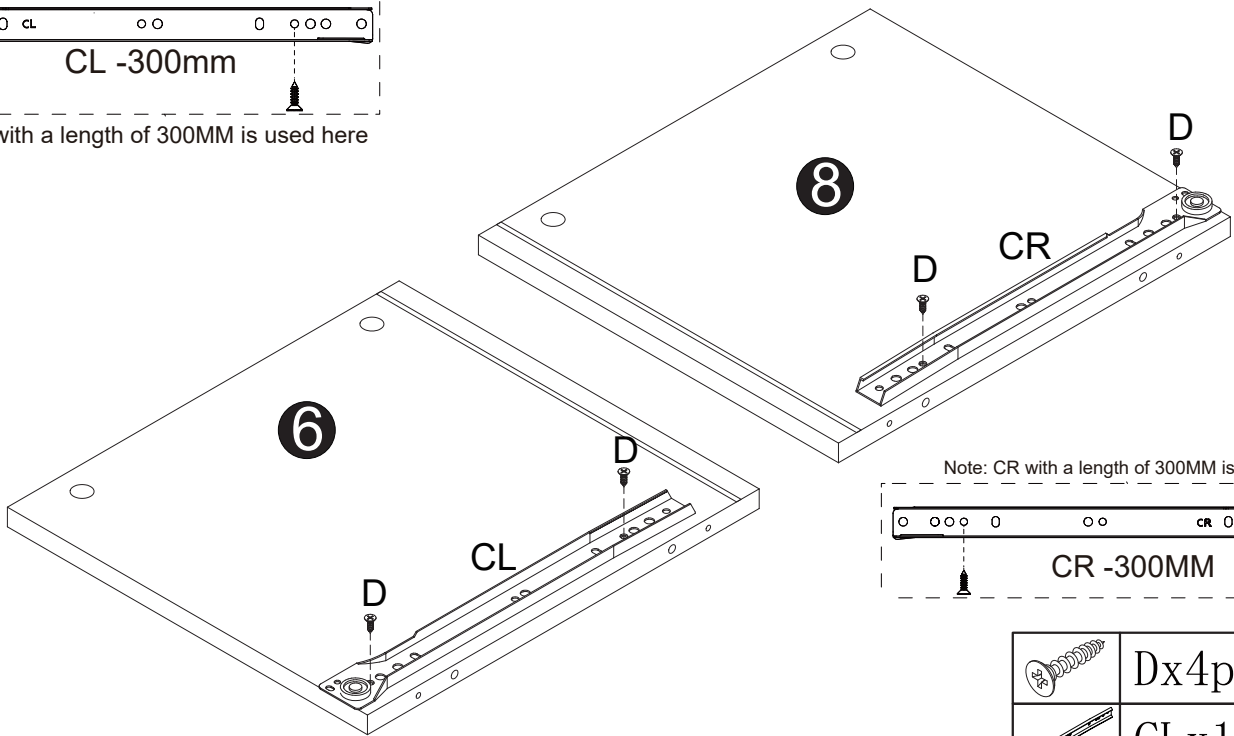

Note: CR with a length of 300MM is used here

	Dx4pcs
	CLx1pcs
	CRx1pcs

STEP 12

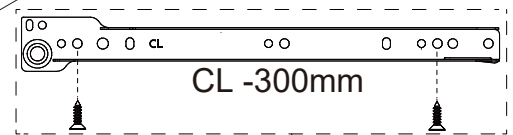
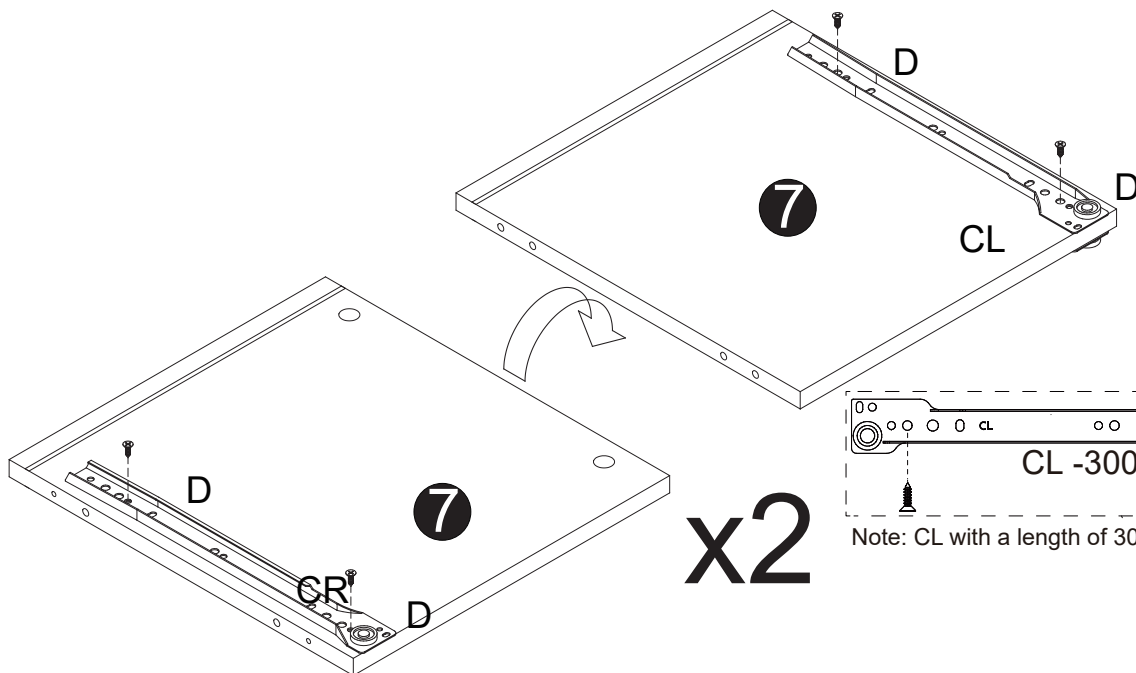

Note: CL with a length of 300MM is used here

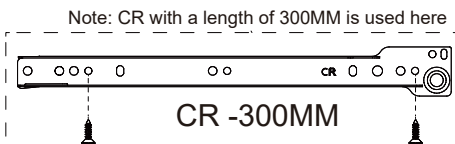

Note: CR with a length of 300MM is used here

	Dx8pcs
	CLx2pcs
	CRx2pcs

Assembly (EN) /Montageschritte (DE)

STEP 13

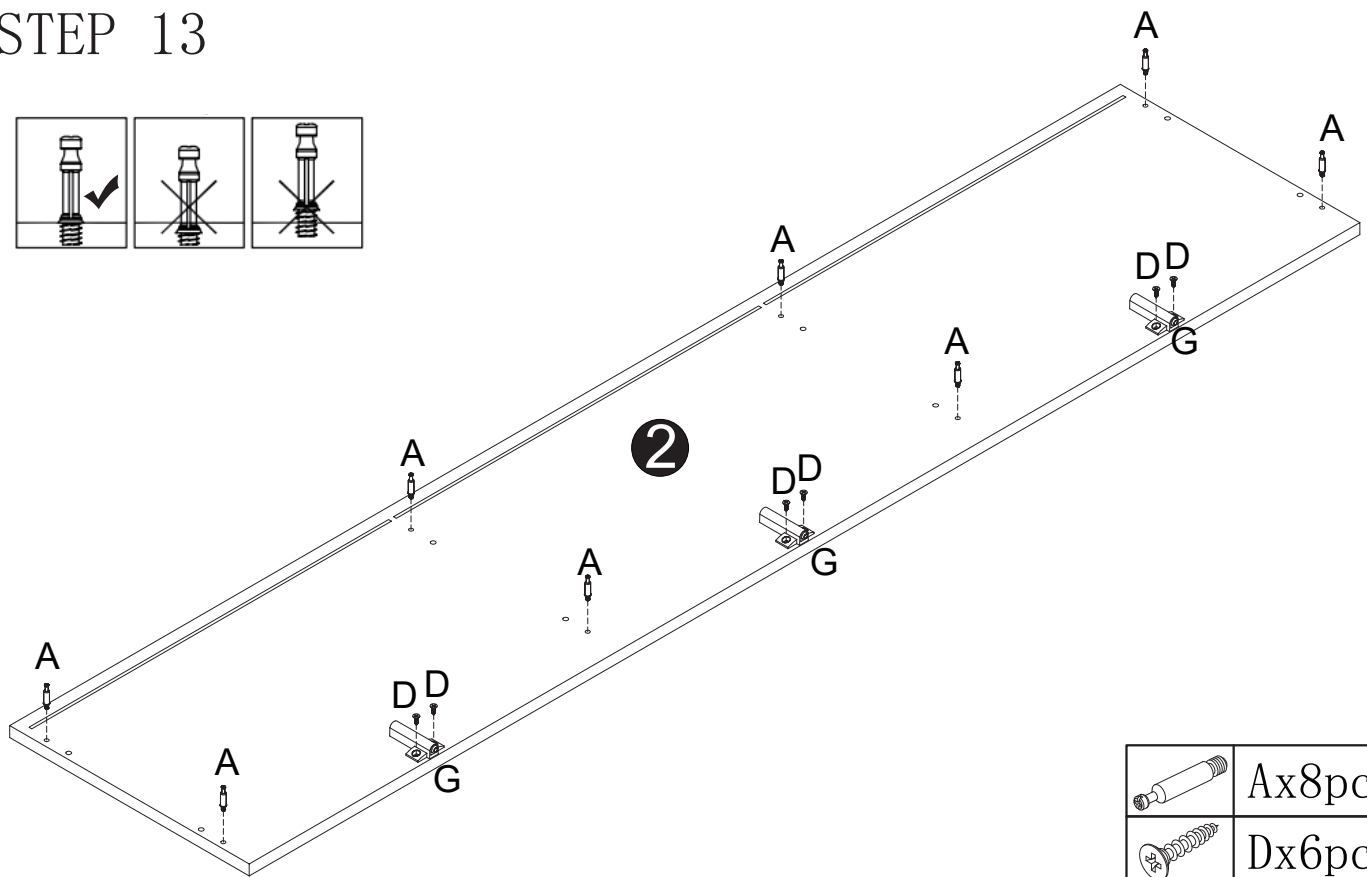
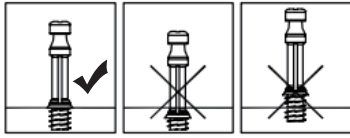

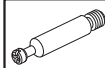
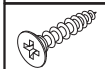
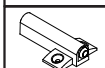
	Ax8pcs
	Dx6pcs
	Gx3pcs

STEP 14

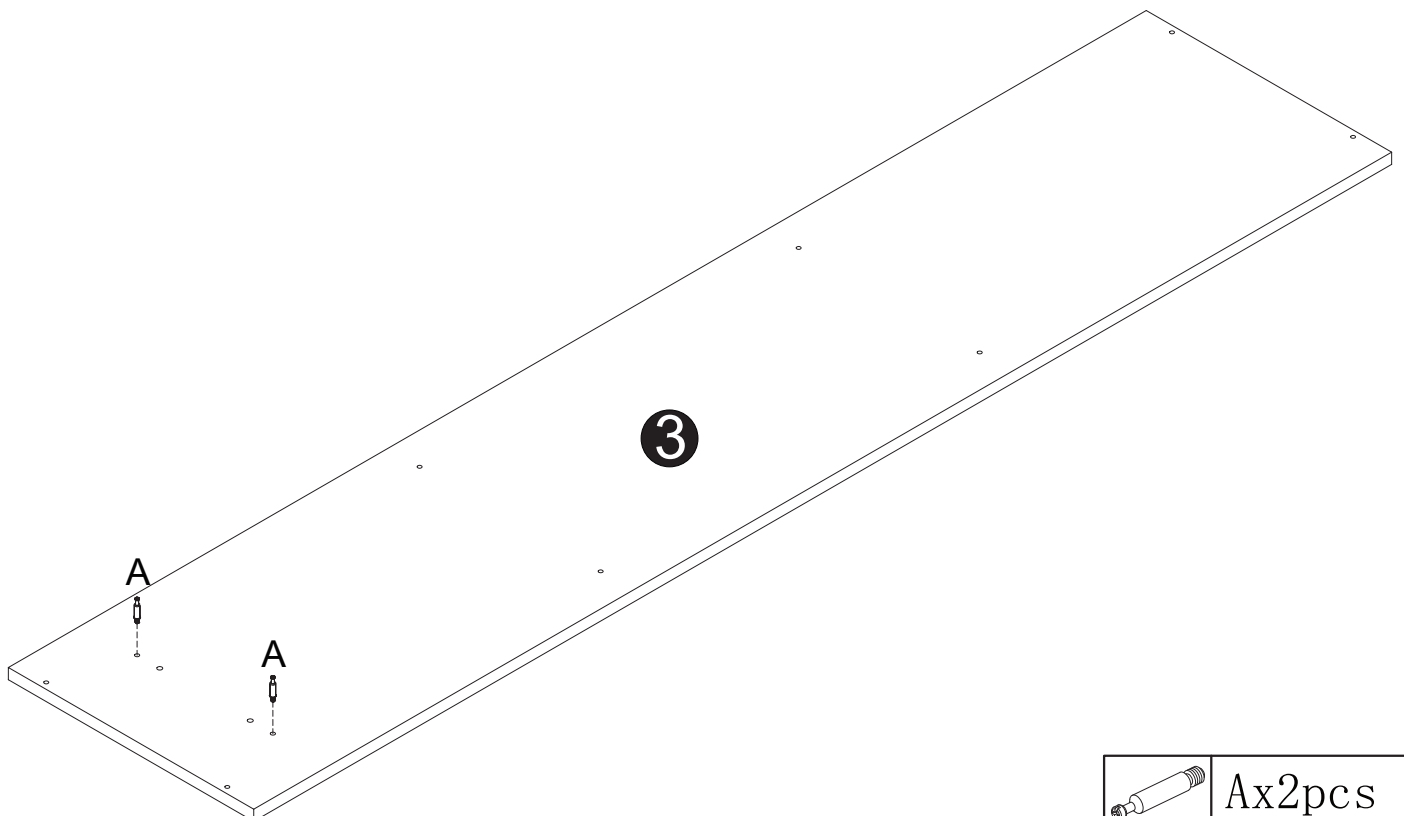
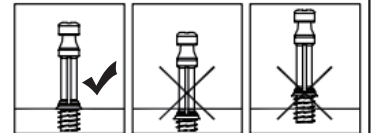

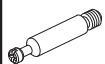

	Ax2pcs
---	--------

Assembly (EN) /Montageschritte (DE)

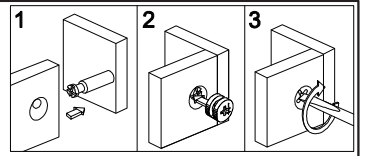
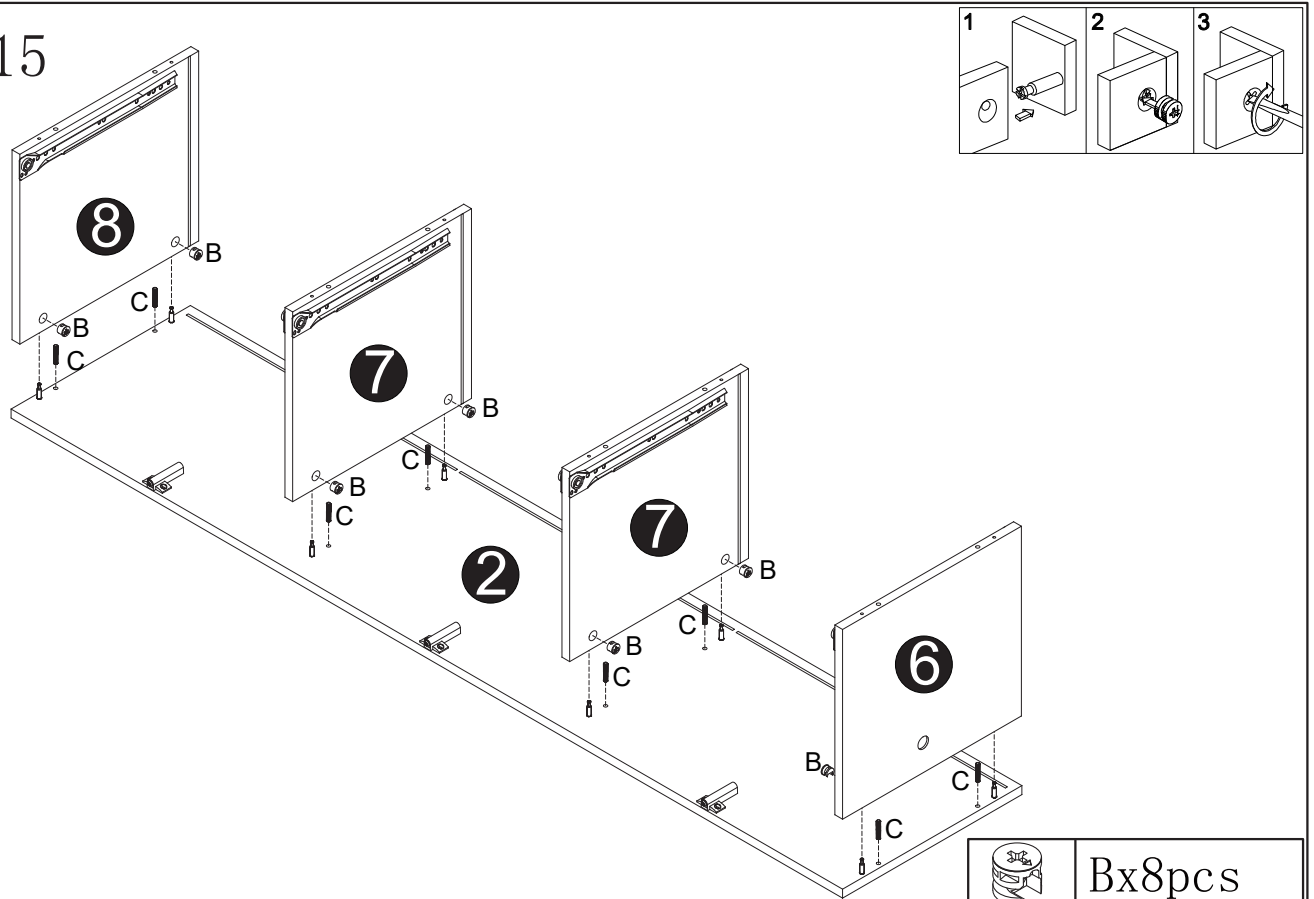
STEP 15



	Bx8pcs
	Cx8pcs

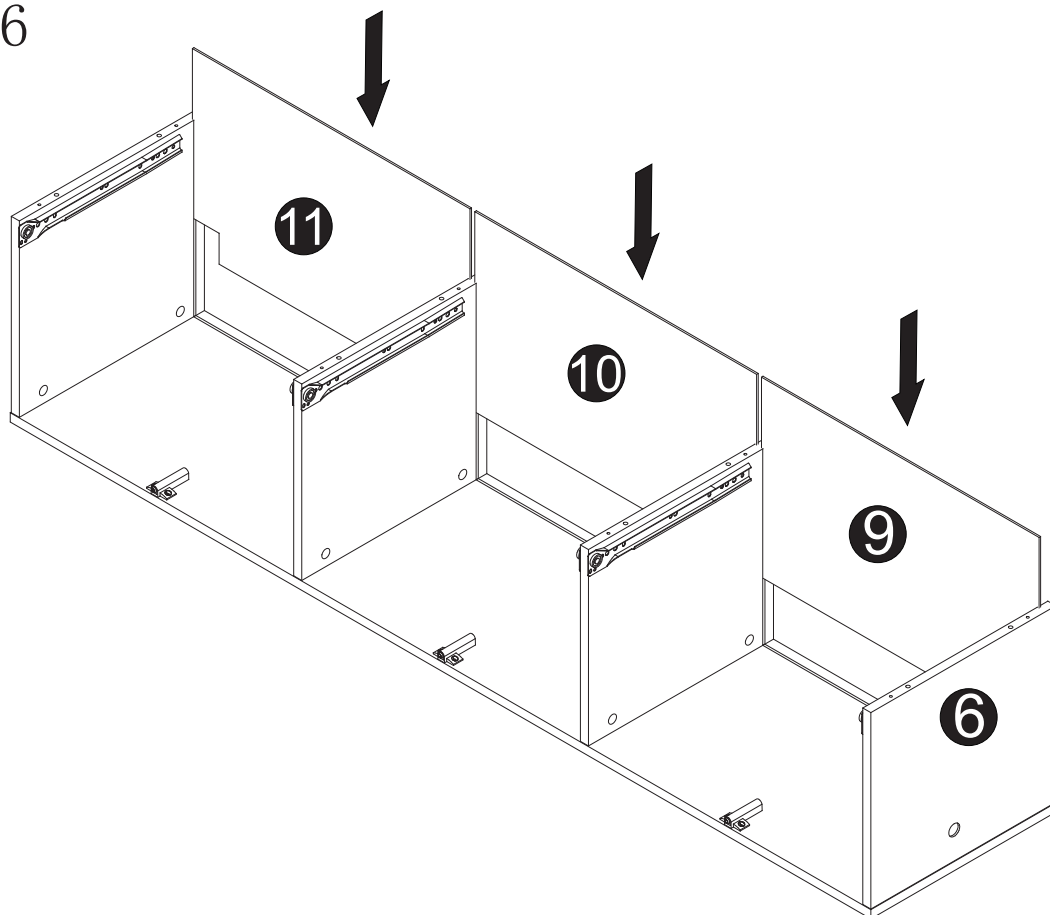

STEP 16



Assembly (EN) /Montageschritte (DE)

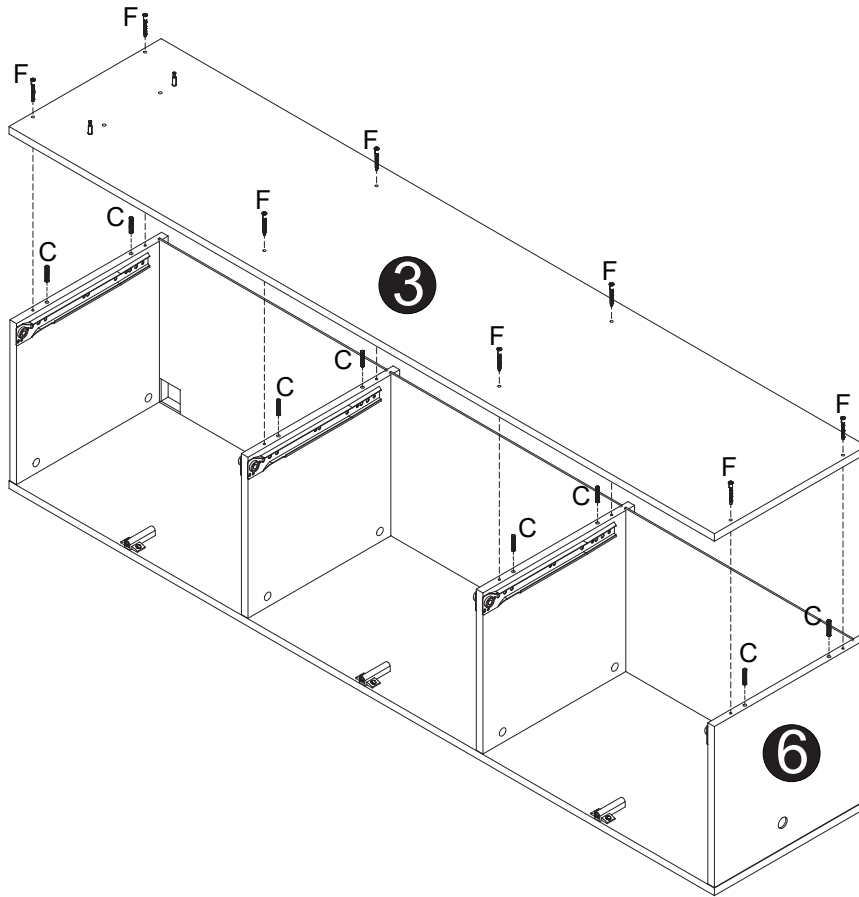

STEP 17

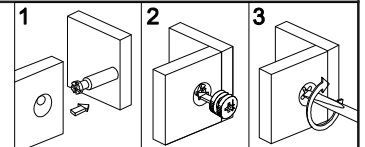
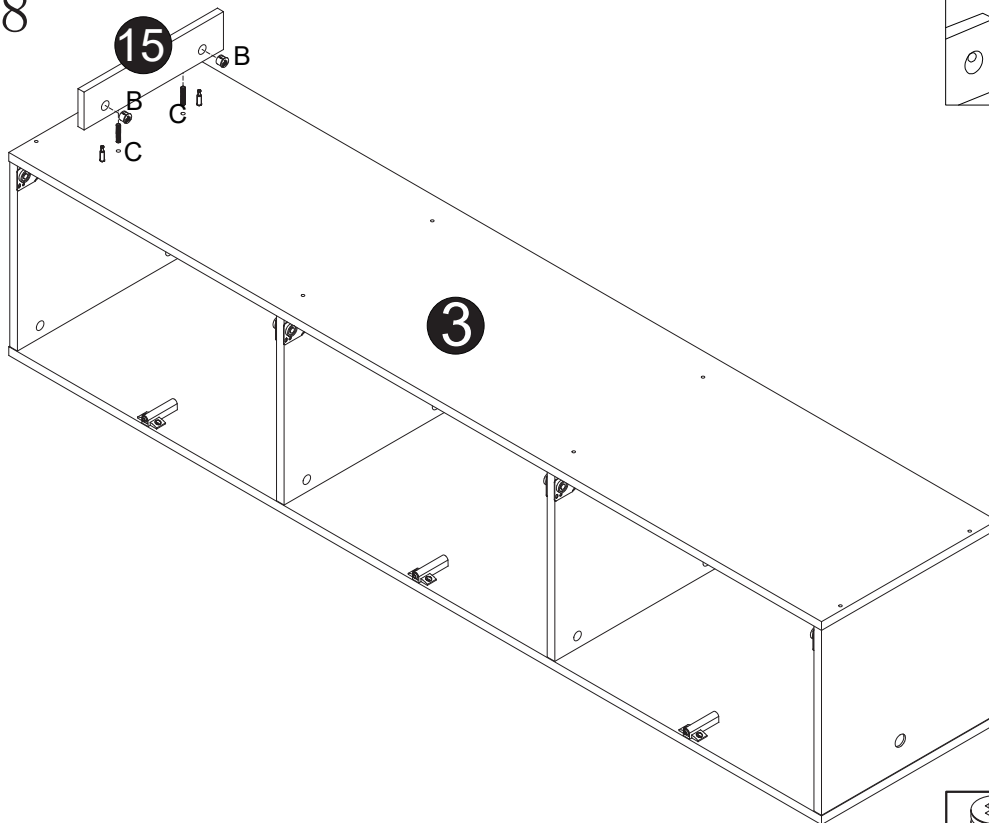

	Fx8pcs
	Cx8pcs

STEP 18



	Bx2pcs
	Cx2pcs

Assembly (EN) /Montageschritte (DE)

STEP 19

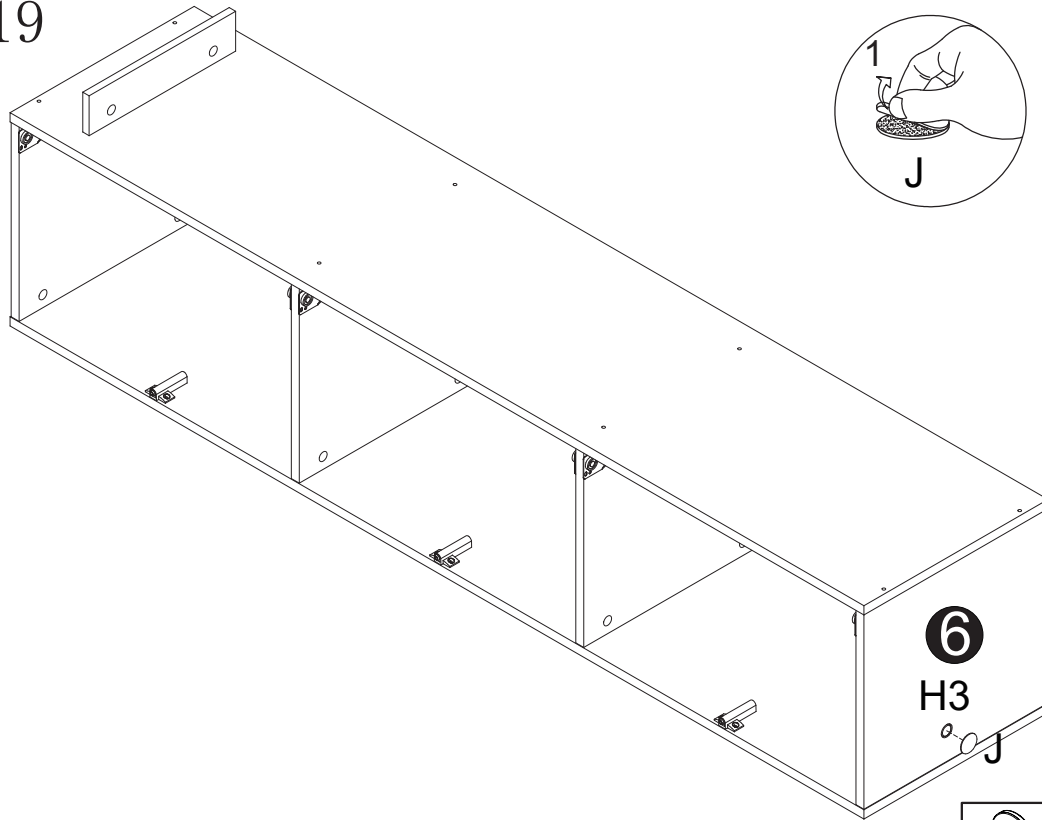

	Jx1pcs
	H3x1pcs

STEP 20

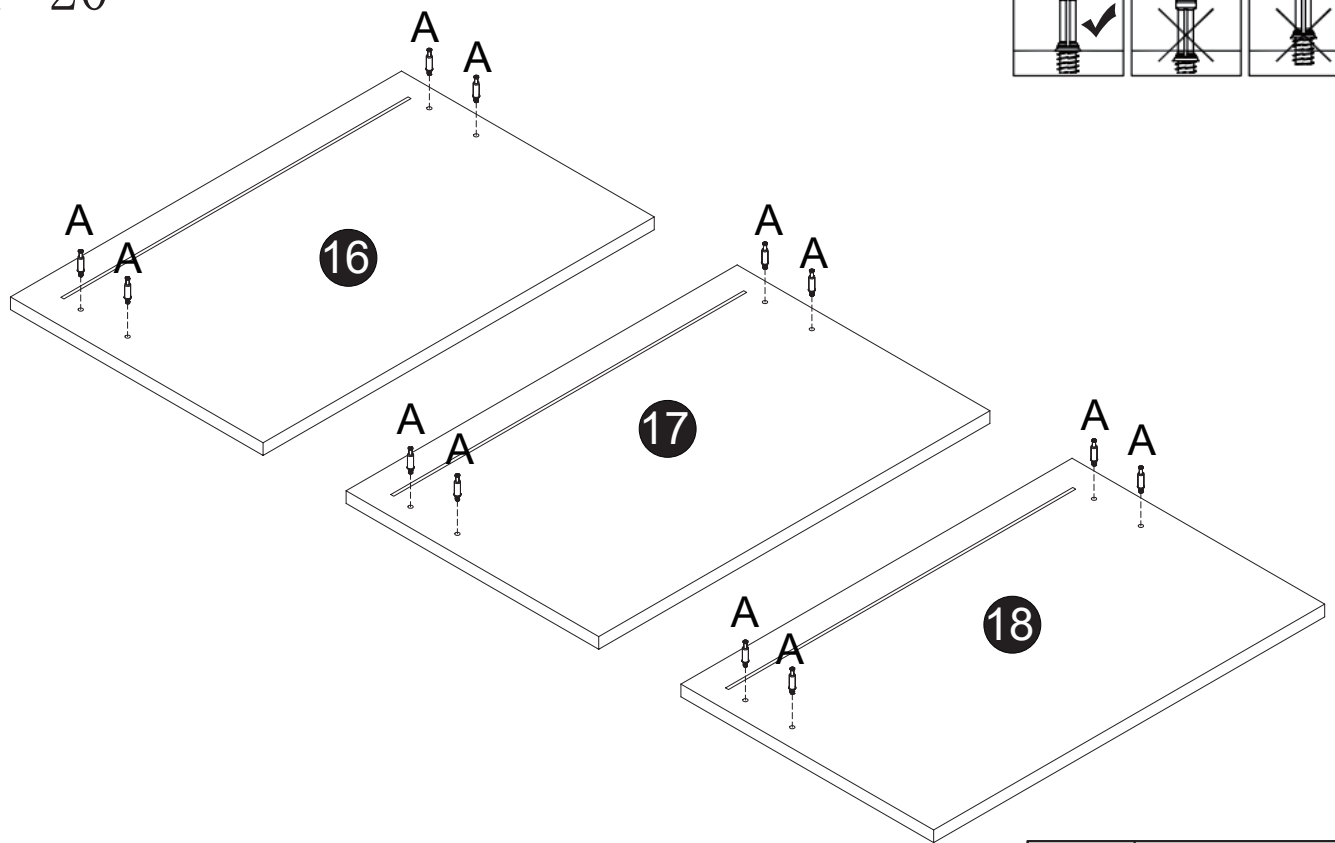

	Ax12pcs
--	---------

Assembly (EN) /Montageschritte (DE)

STEP 21

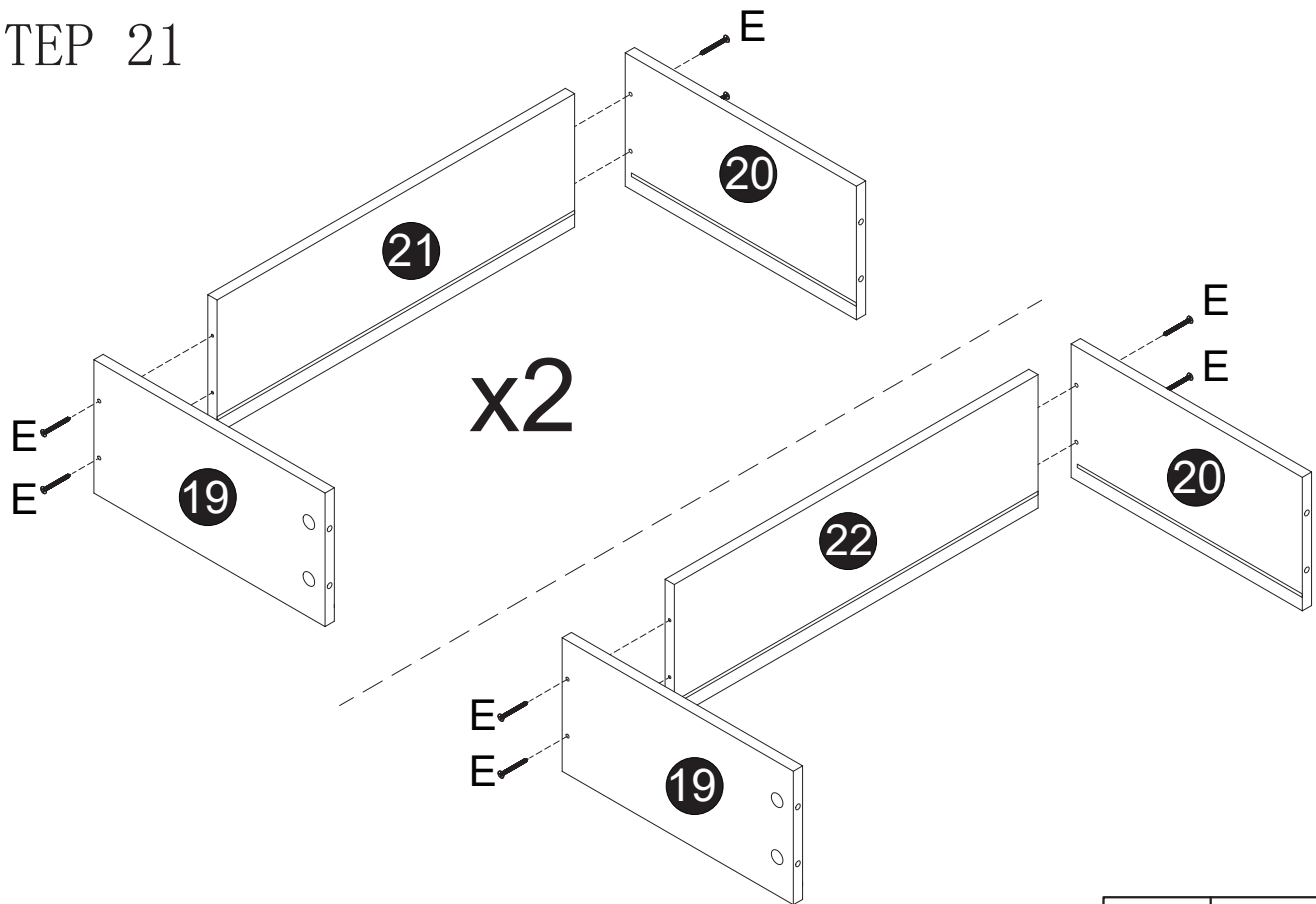

 Ex12pcs

STEP 22

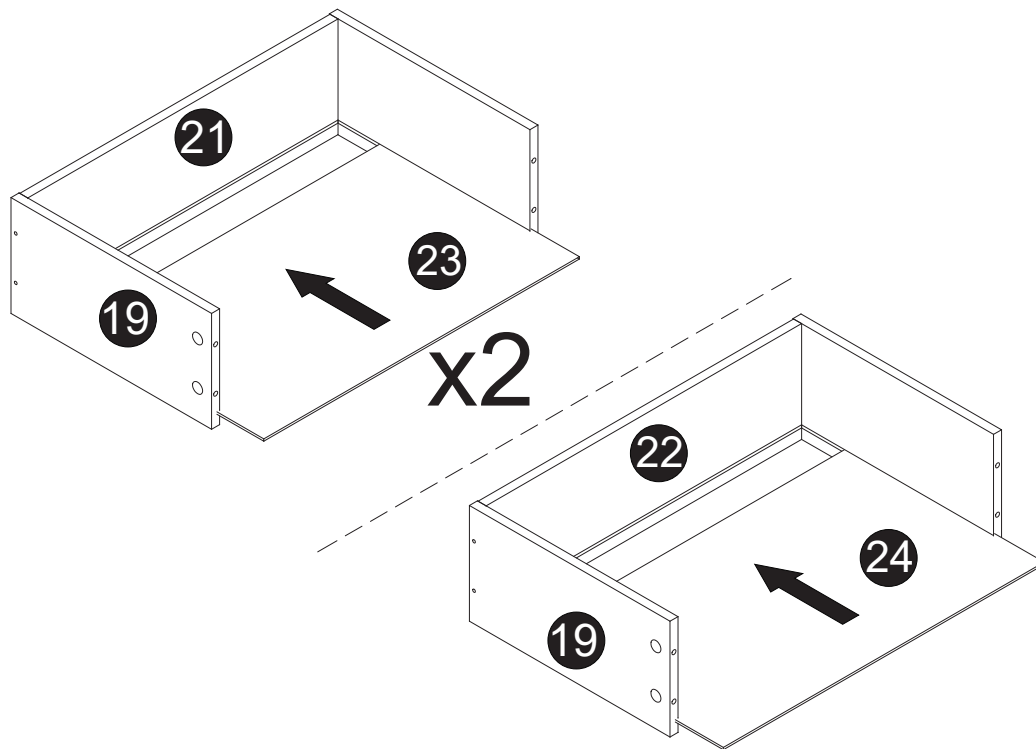

Assembly (EN) /Montageschritte (DE)

STEP 23

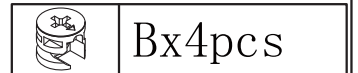
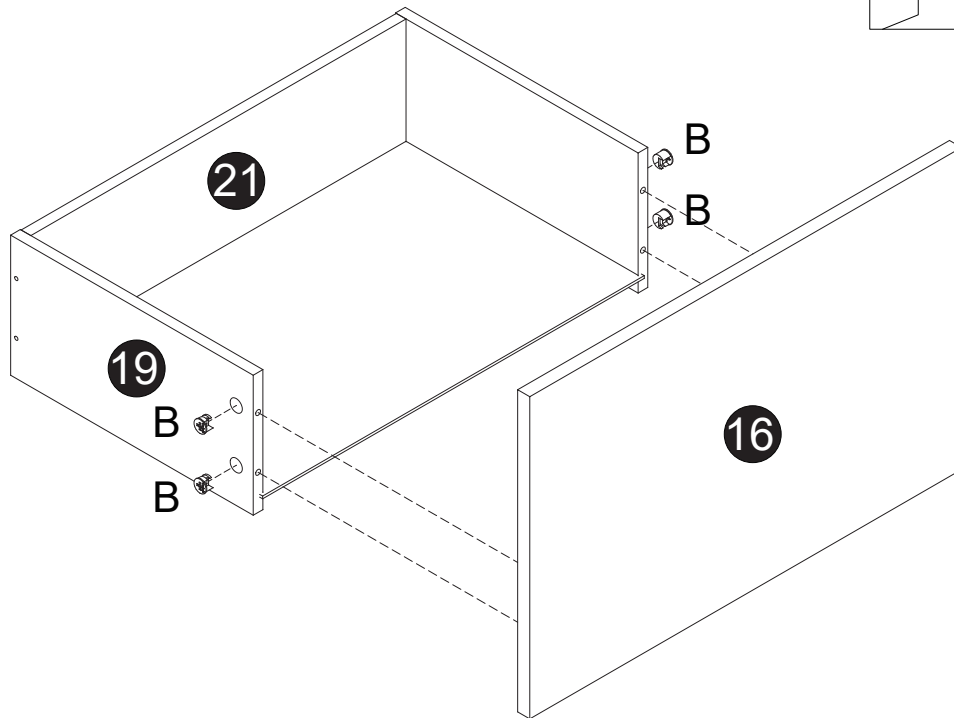
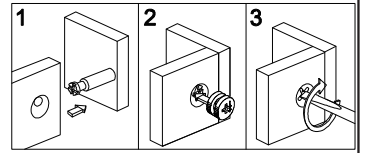

STEP 24

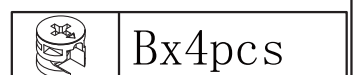
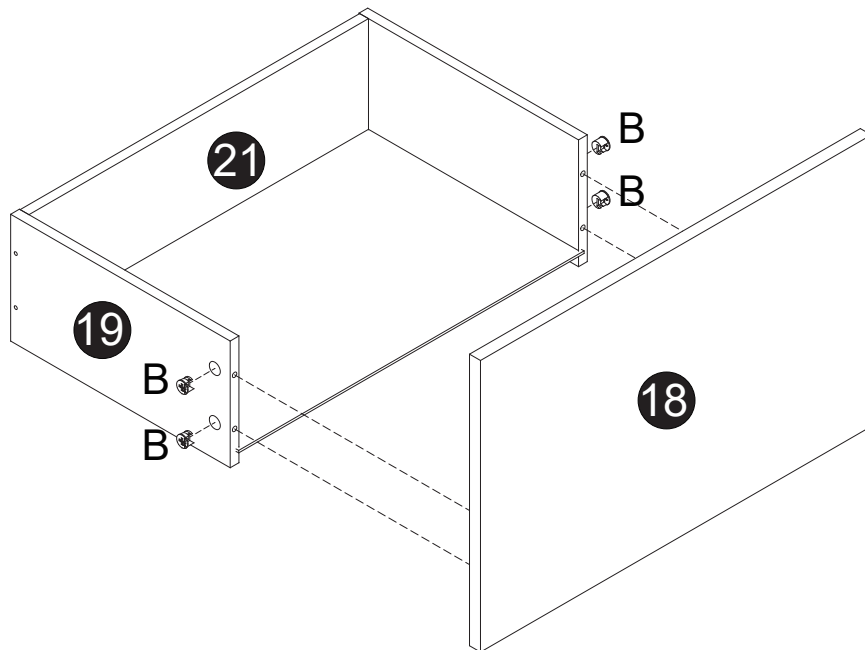
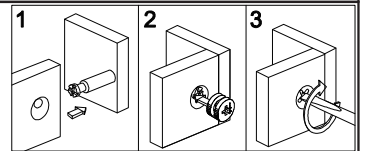

Assembly (EN) /Montageschritte (DE)

STEP 25

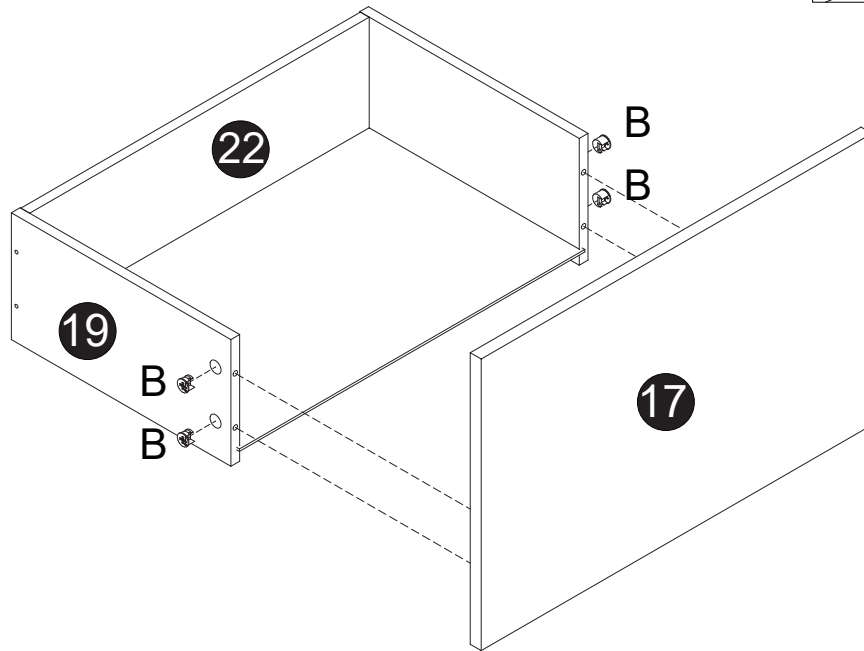
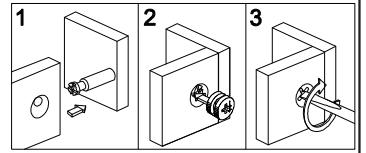

	Bx4pcs
--	--------

STEP 26

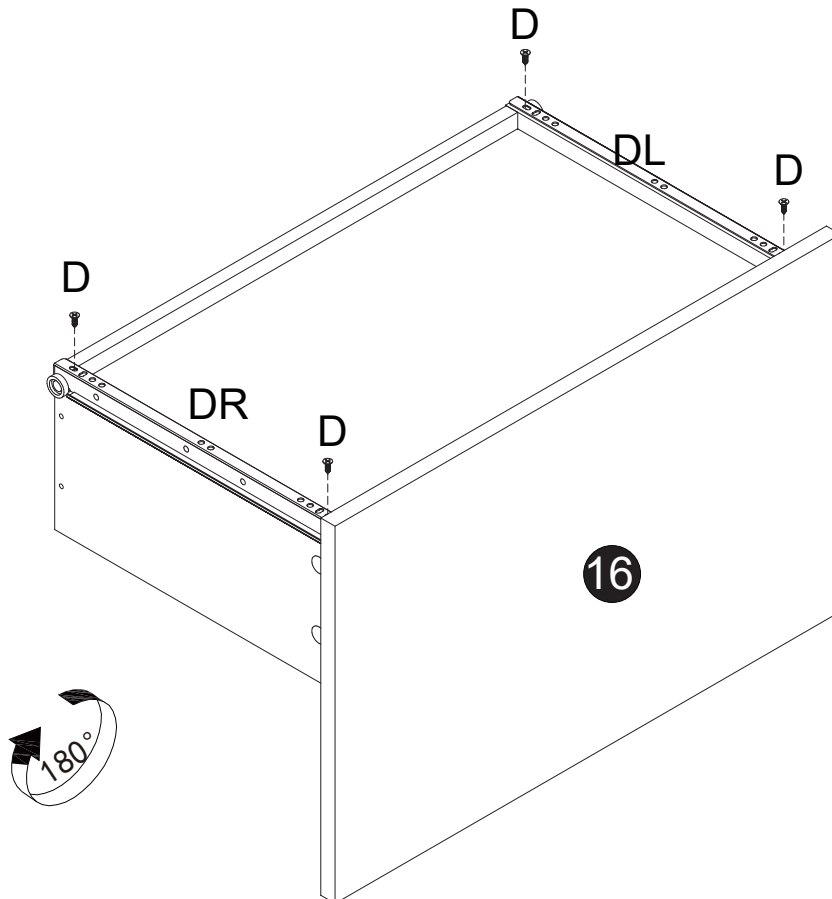



	Dx4pcs
	DLx1pcs
	DRx1pcs

Assembly (EN) /Montageschritte (DE)

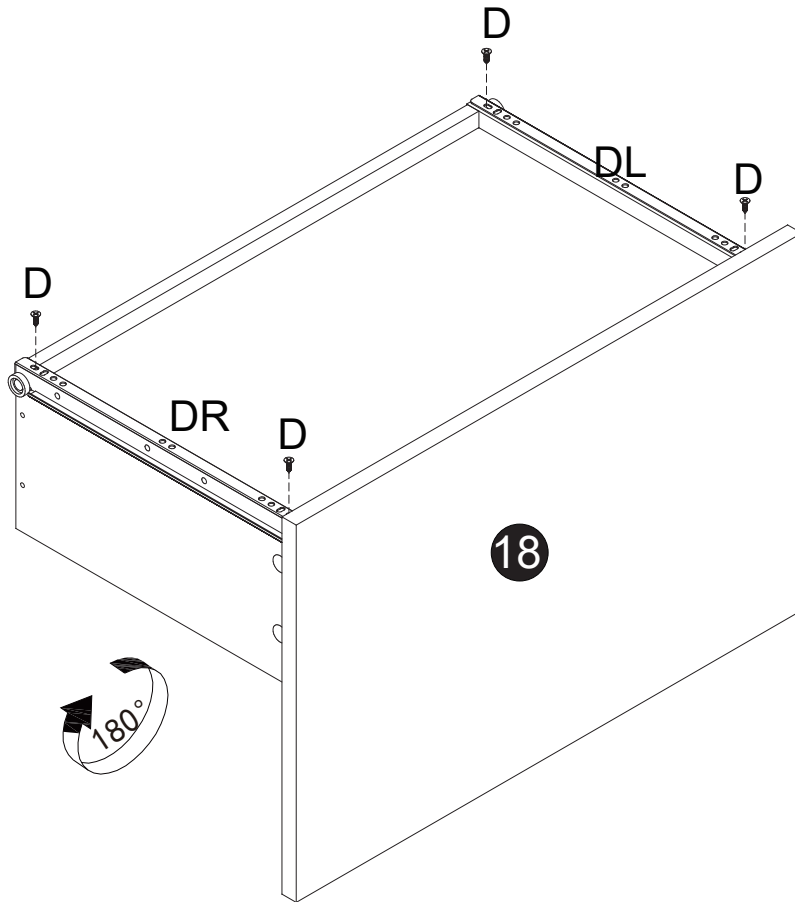

STEP 27

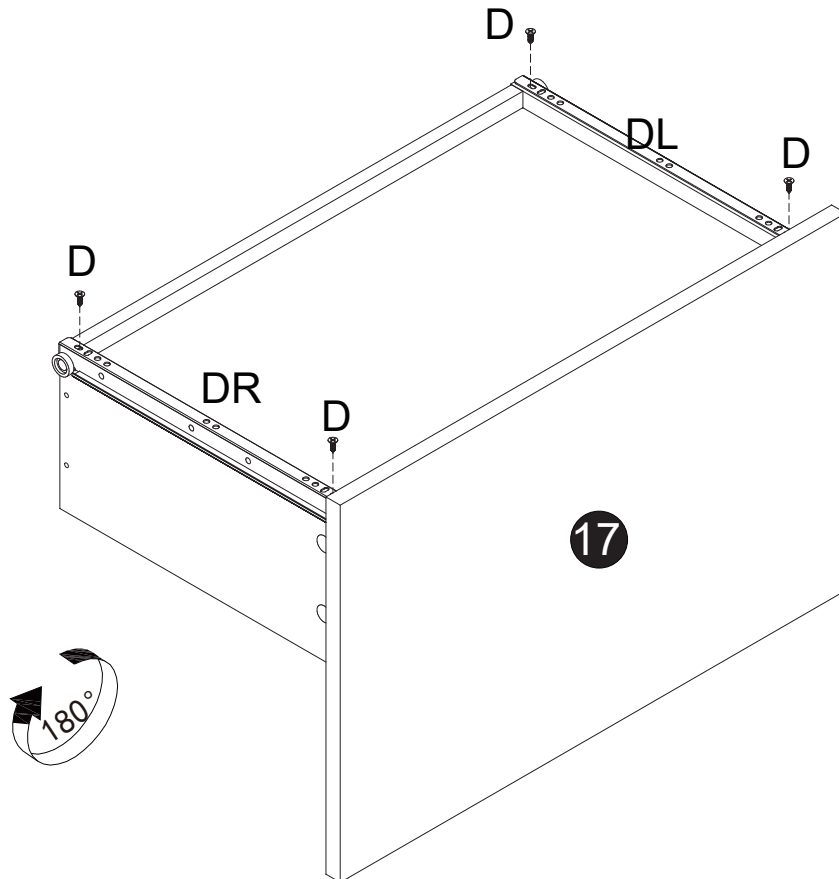

	Dx4pcs
	DLx1pcs
	DRx1pcs

STEP 28



	Dx4pcs
	DLx1pcs
	DRx1pcs

Assembly (EN) /Montageschritte (DE)

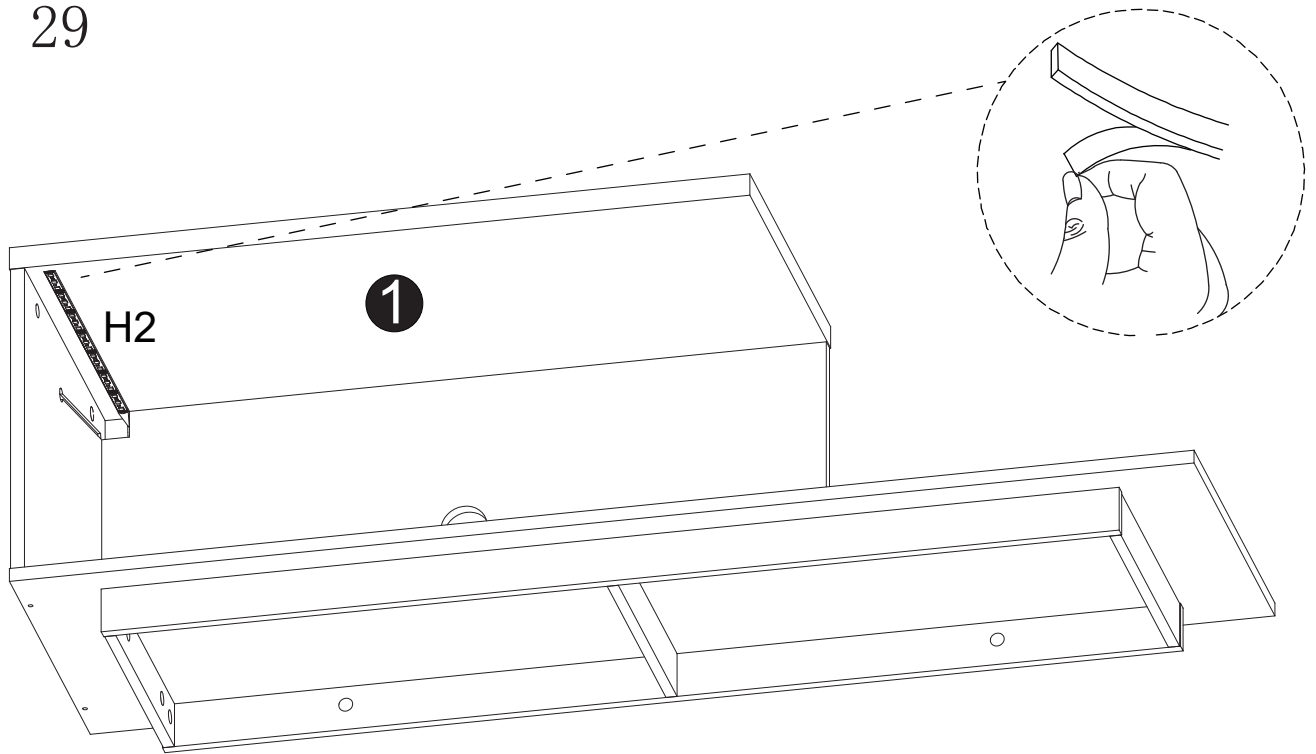

STEP 29

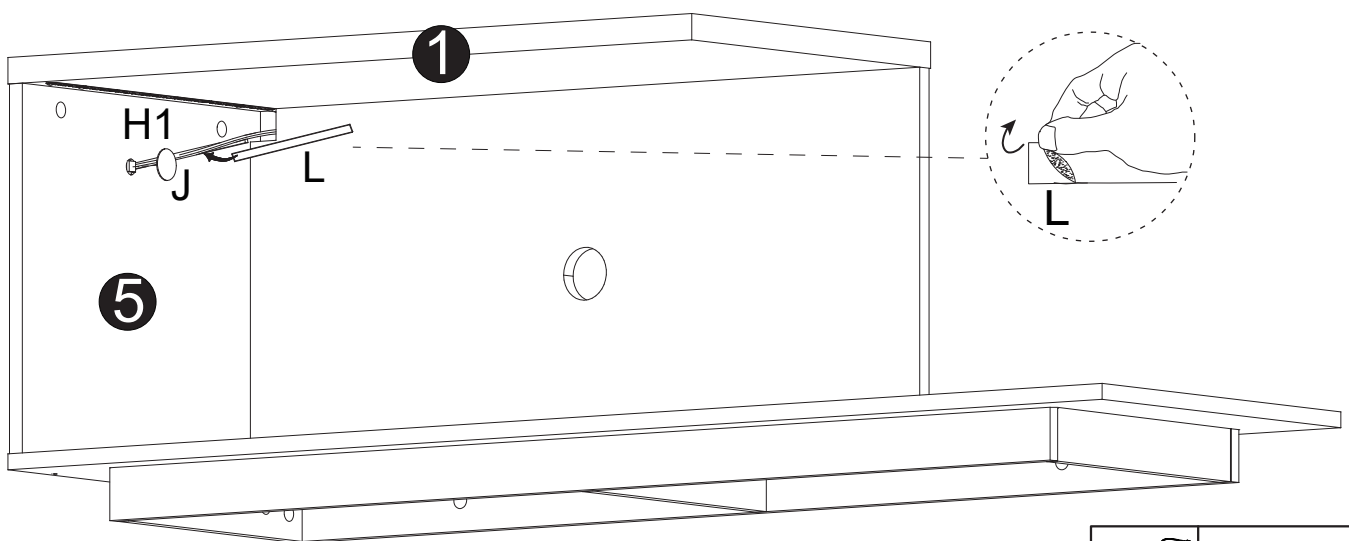
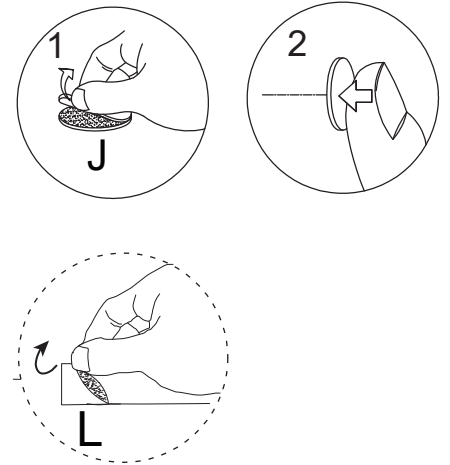

	H2x1pcs
---	---------

STEP 30



	H1x1pcs
	Lx1pcs
	Jx1pcs

Assembly (EN) /Montageschritte (DE)

STEP 31

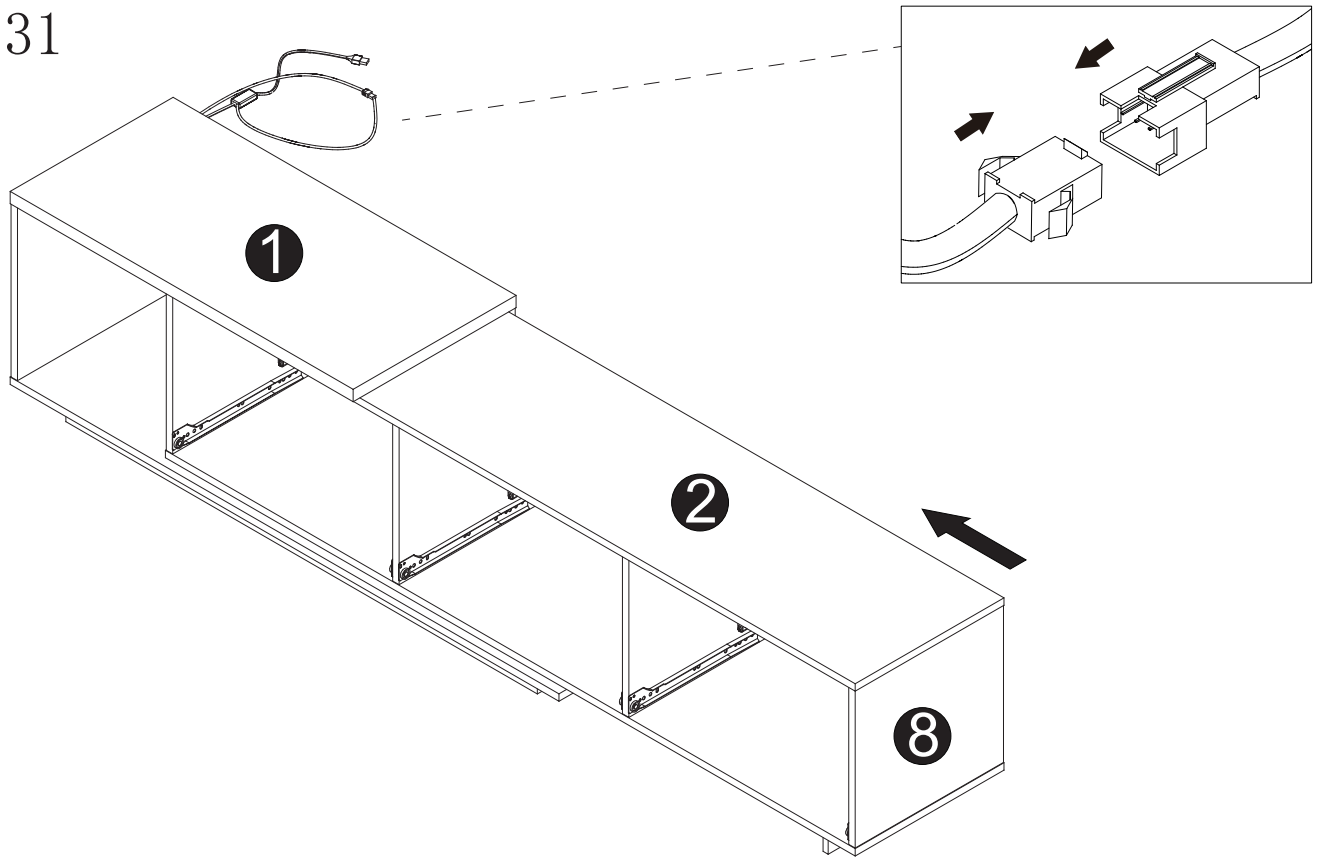

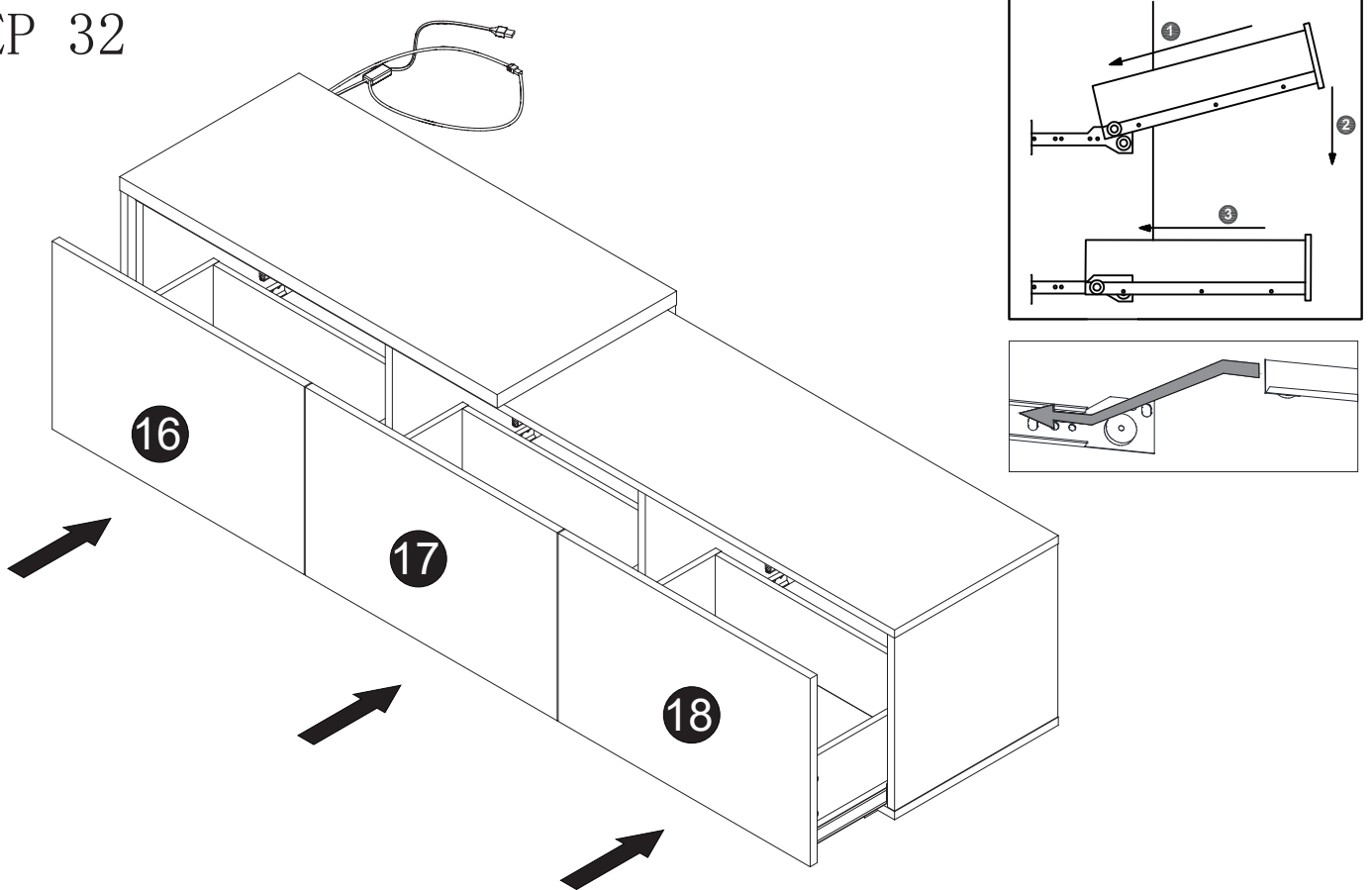

STEP 32

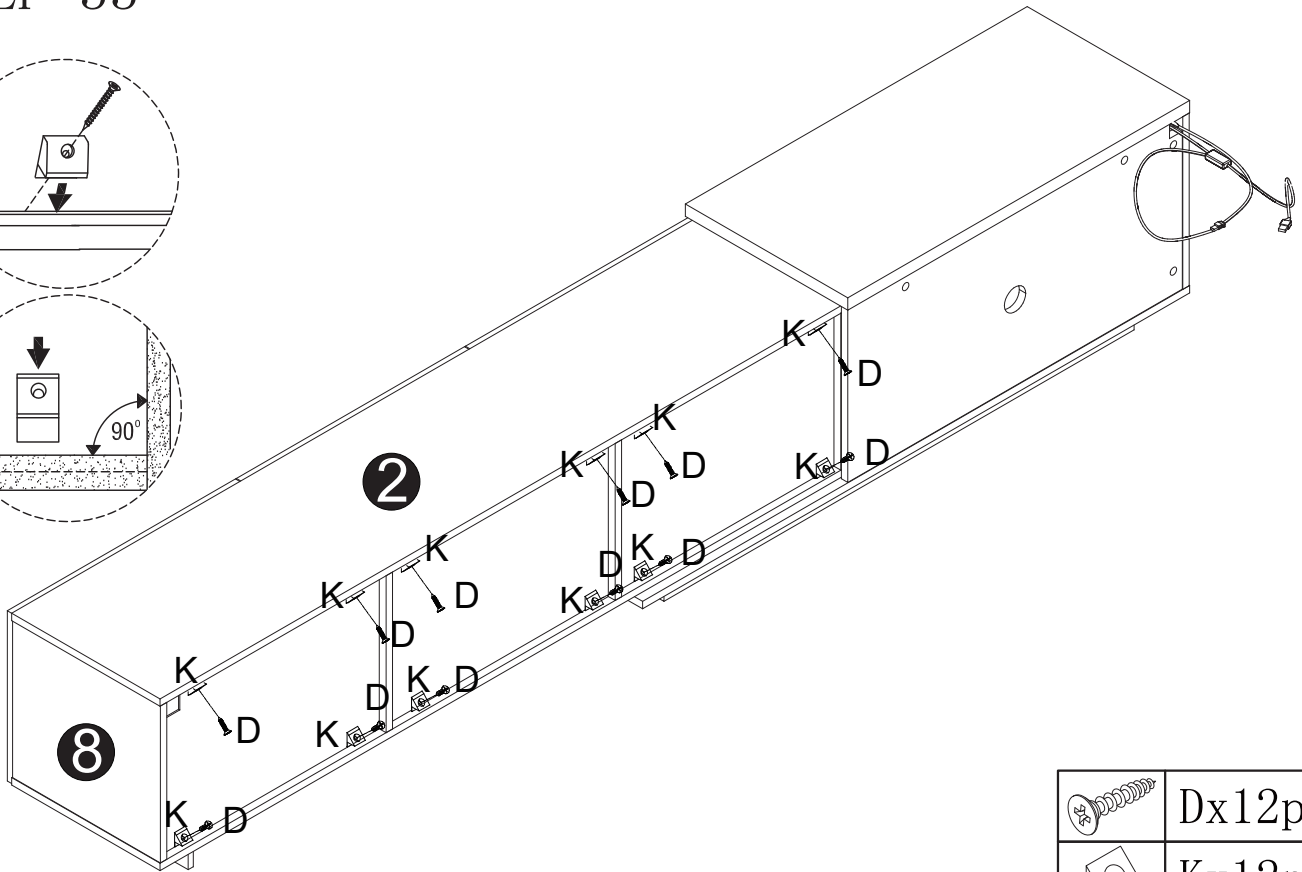
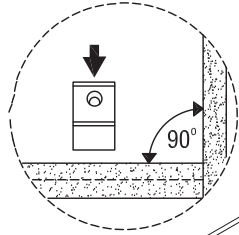
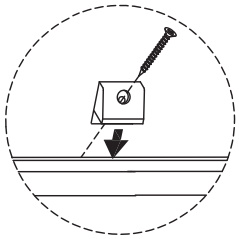

Assembly (EN) /Montageschritte (DE)

STEP 33



	Dx12pcs
	Kx12pcs