

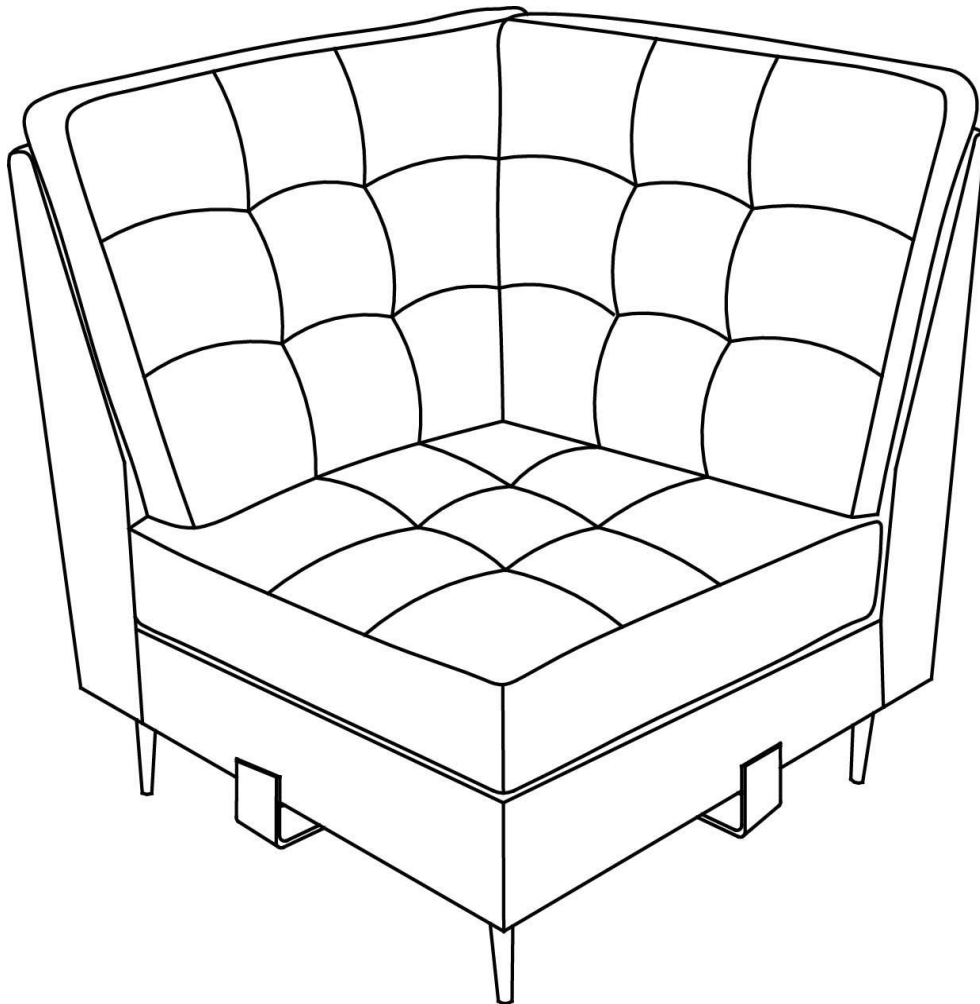

Assembly Instructions

Caution: You must read this before you proceed



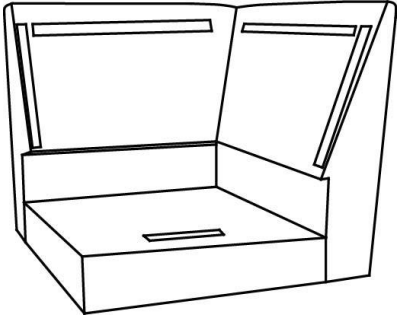
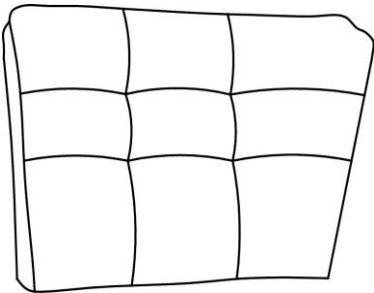
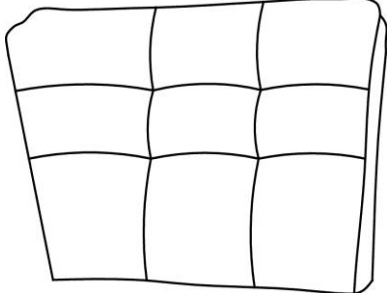
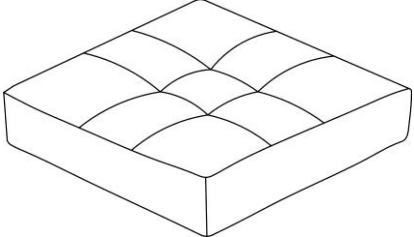

Corner Seat

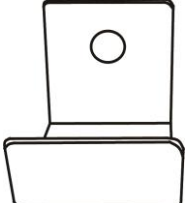

Parts List

Label	Picture	Description	QTY
A		Conner Seat	1
B		Left Back Cushion	1
C		Right Back Cushion	1
D		Seat Cushion	1
E		Leg	4
F		Metal Bracket	2

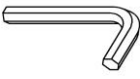
Hardware

Label	Picture	Description	QTY
①		Bolt (M8*25mm)	3
②		Washer(M8)	19
③		Bolt (M6*30mm)	17
④		Allen Wrench(M8)	1
⑤		Spring Washer(M8)	19
⑥		Allen Wrench(M6)	1

Assembly Preparation

Before Beginning Assembly:

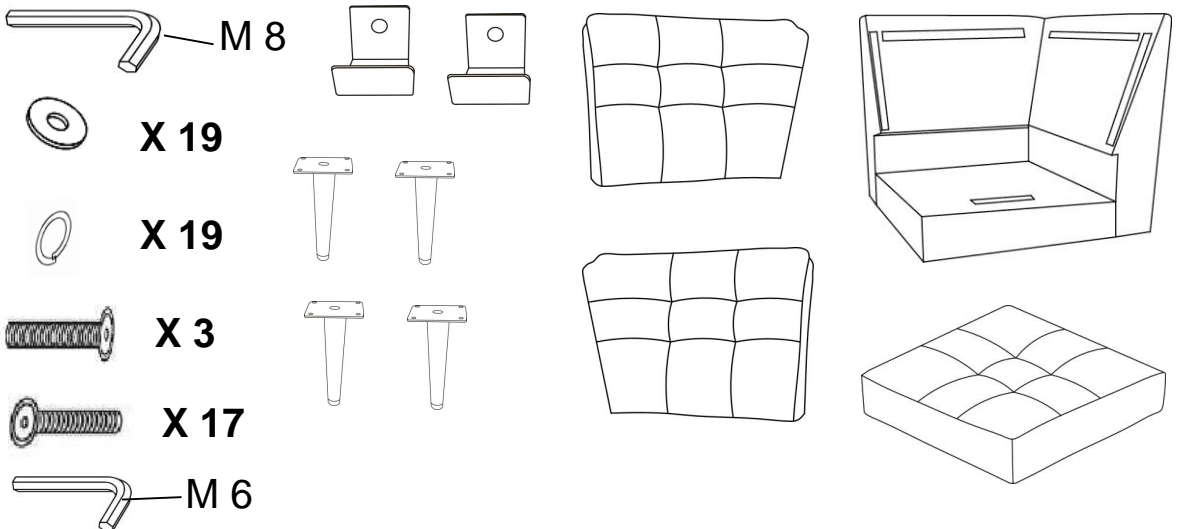

- M 8
- X 19
- X 19
- X 3
- X 17
- M 6



- Read instructions, cover to cover-



- Have 2 adults on hand for assembly-



- Do not assemble on flooring or carpet-



- Assemble on a clean non-marring surface (packing foam)-



- Save all packaging until finished-

Assembly Steps

Overview

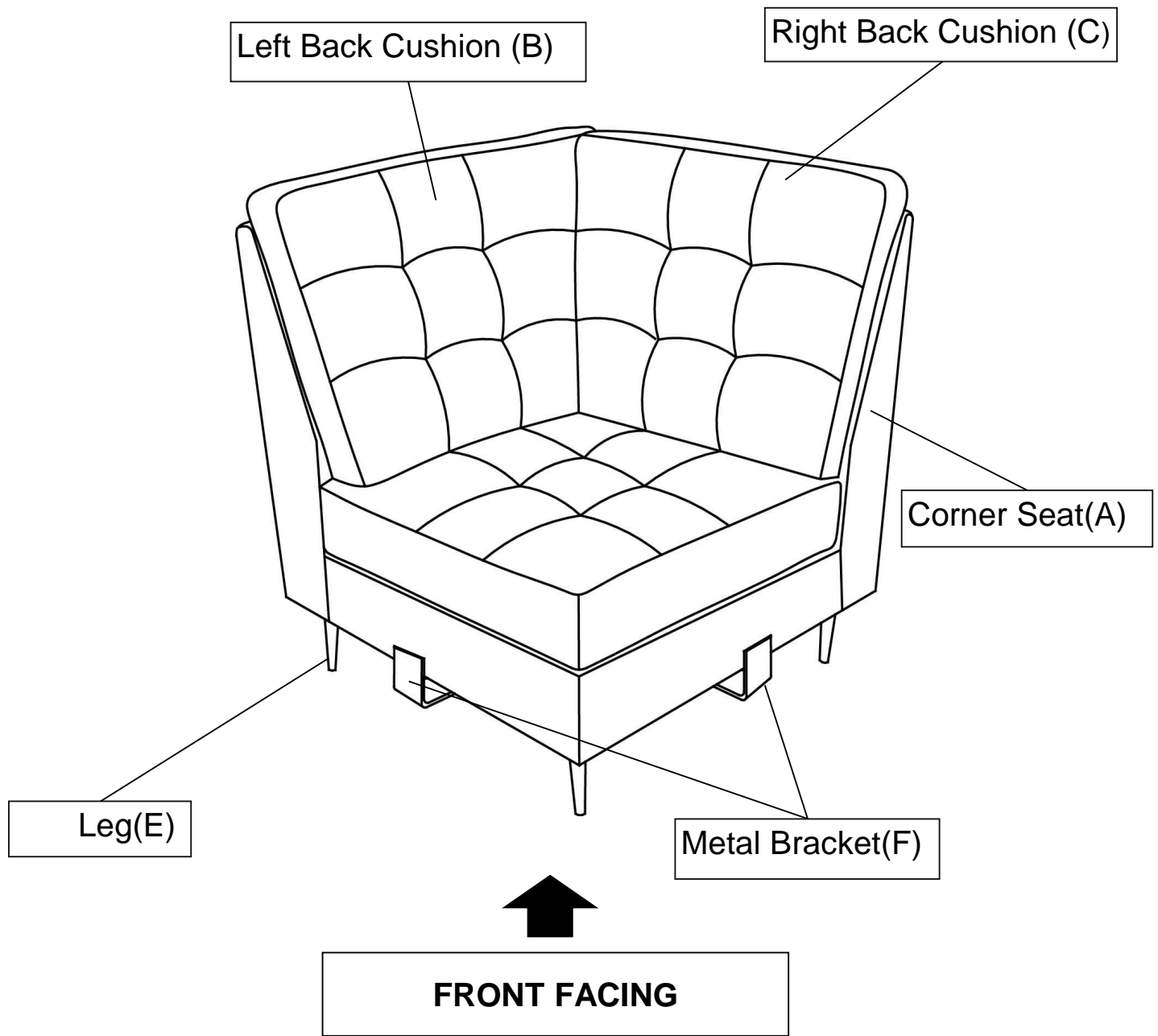

This Corner has multiple parts and may require up to 30 minutes to assemble. To give you an overview of the Corner parts, the above picture is to help you put the various parts into perspective. Please read through the instructions below to familiarise yourself with the parts and steps before assembly.

Note: It is recommended that you have an adult partner to assist during the entire assembly process.

Step 1

Corner Seat(A)

Metal Bracket(F)

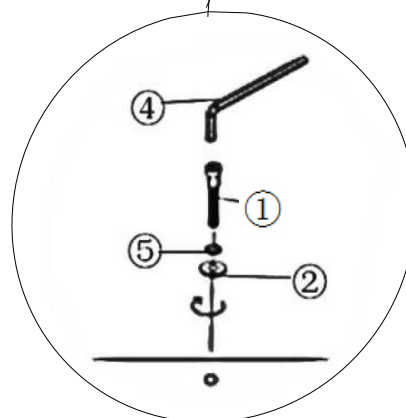
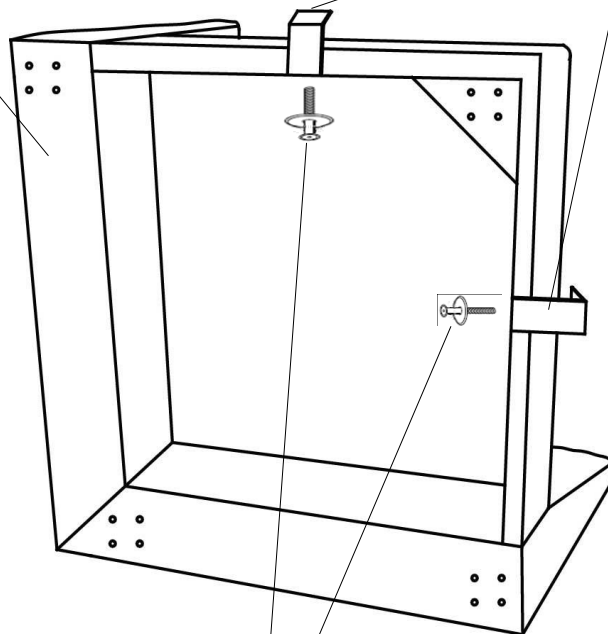

Attach the Metal Brackets(F) to the Corner Seat using Bolts(①), Spring Washers(⑤), and Washers(②) with the Allen Wrench(④) .
Tighten the Bolts fully in a sequential manner.

Step 2

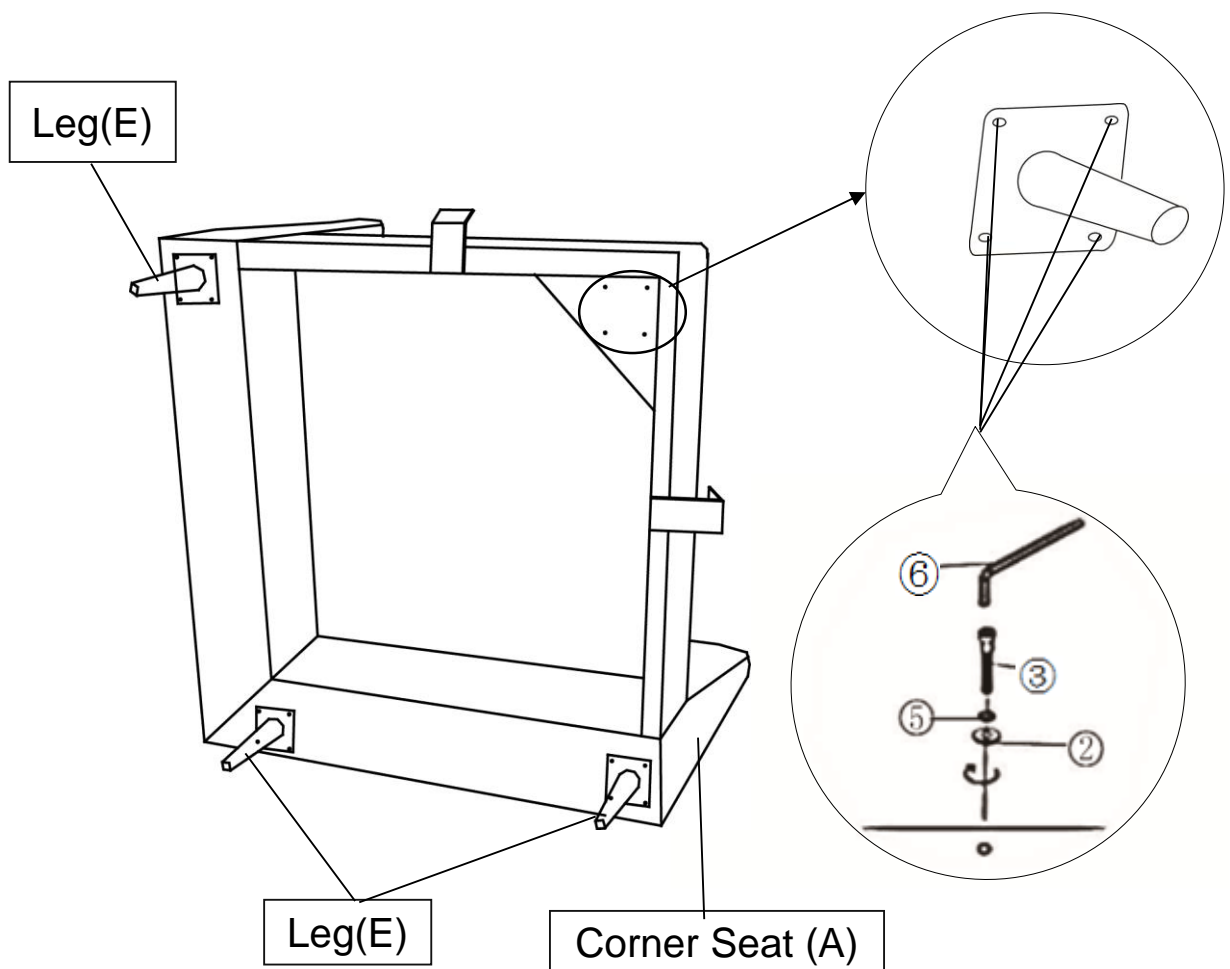

Install the Legs(E) at the bottom of the Corner Seat using Bolts(③), Spring Washers(④), and Washers(②) with the Allen Wrench(⑥) as pictured above.
Note: Please keep the Allen key in a safe place for future use. You may need to tighten the Bolts again with the Allen key if the product were to loosen during use.

Step 3

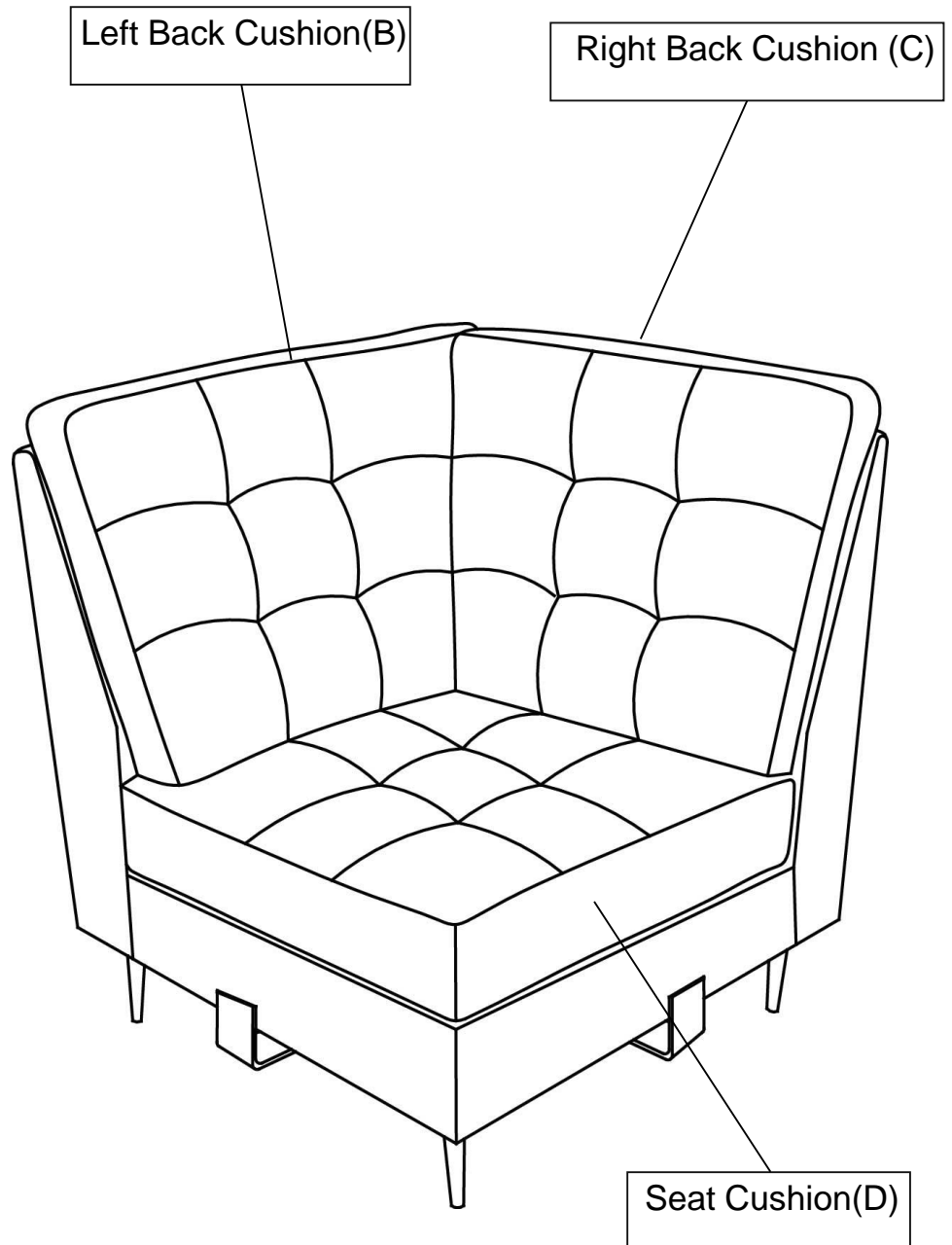

Place the Seat Cushion(D), the Left Back Cushion (B) and the Right Back Cushion (C) onto the Corner.

Your Corner is ready for use.

This Corner can only be used on a flat, level surface.

Additional Steps

Step 1

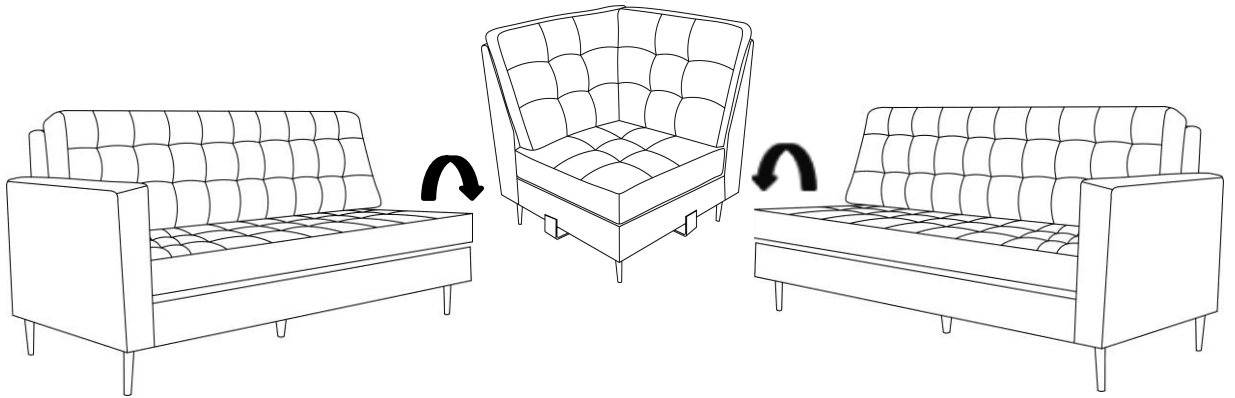

Connect the Sofas by intersecting the metal brackets.
Make sure all parts are connected and securely locked into position.

Step 2

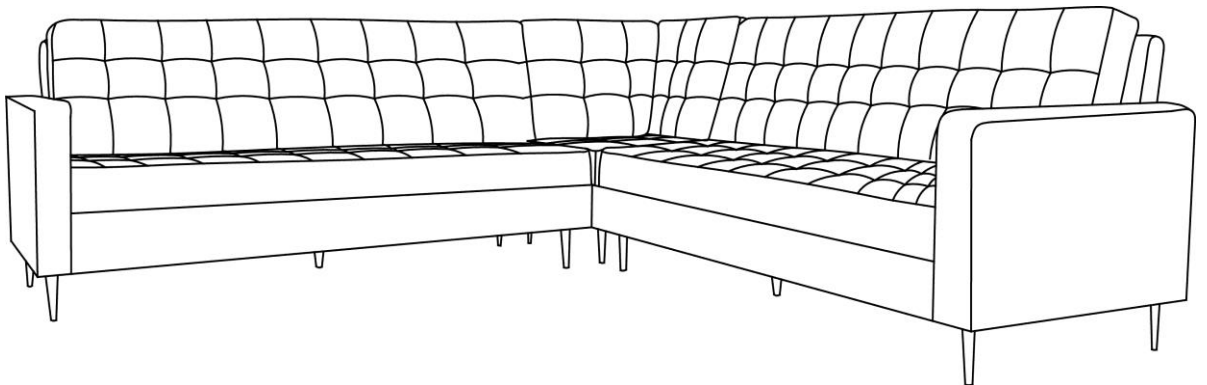

Your Sofa Set is ready for use.
This Sofa Set can only be used on a flat level surface.

Care & Maintenance



- Furniture may scratch floors. We recommend using furniture pads to protect your floors.



- Do not put hot items directly on furniture surface.



- Do not clean furniture with harsh cleansers or polish.



- Do not place furniture under direct sunlight.



- Do not place furniture near heating or cooling vents.



- Do not write on furniture without a padded barrier to protect the surface.



- Do not place furniture outside . For indoor use only.



- Not for commercial use. For residential use only.



- Stains may be removed with mild soap solution and damp cloth.



- Children should not climb or jump on the furniture.



- Dust and pick-up spills using a clean, non-colored, lint-free cloth.