

## ASSEMBLY INSTRUCTIONS DROP LEAF DINING TABLE

**IMPORTANT: READ THESE INSTRUCTIONS CAREFULLY BEFORE ASSEMBLING OR USING YOUR DINING TABLE.**

**PLEASE KEEP THESE INSTRUCTIONS FOR FUTURE REFERENCE**

### **HEALTH & SAFETY:**

**DO NOT** use this item if any parts are missing, damaged or worn

**DO NOT** use this item unless all fixings are secured.

Please keep small parts out of reach of children.

Always use on a level, even surface

### **CARE & MAINTENANCE:**

Assemble in the room of use.

Periodically check all screws and fixings to ensure they are secured.

**DO NOT** push the item as this will damage the legs.

Always lift the item with 2 people to reposition.

Keep any sharp objects away from the item.

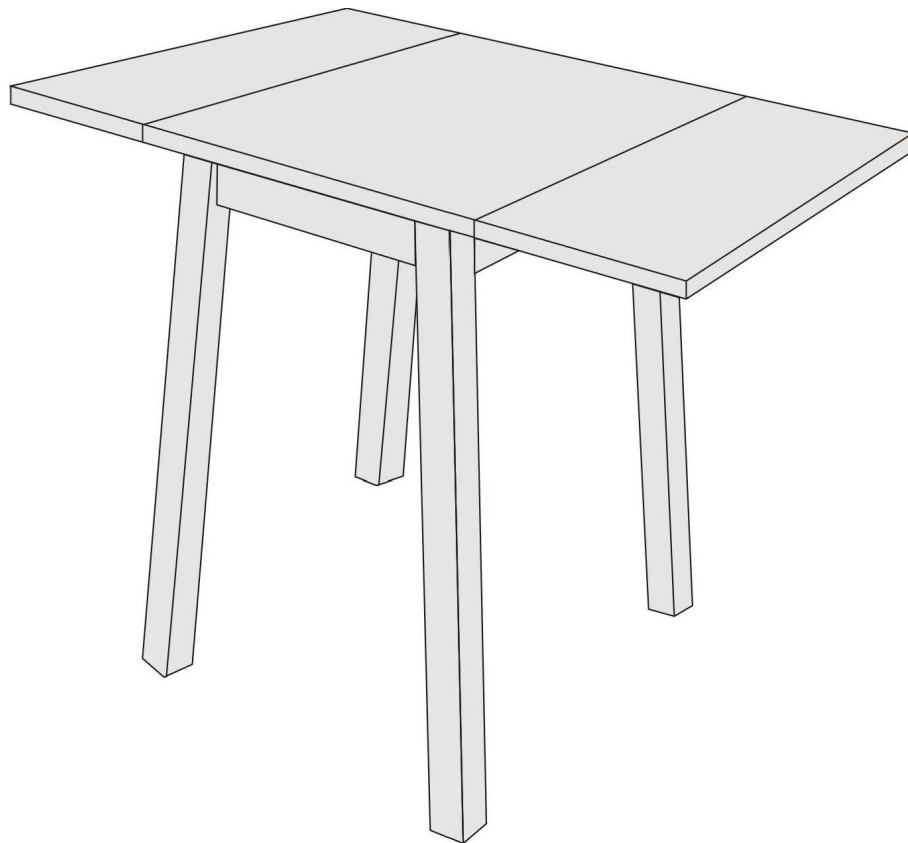





## PARTS LIST

PART	DESCRIPTION	BOX	QTY
1	TABLE TOP	1	1PCS
2	TABLE LEG	1	4PCS

\*You will need a screwdriver and small mallet (not provided).

## HARDWARE LIST

PART	DESCRIPTION	QTY
A	JCBC SCREW M6 X 60MM 	8PCS
B	SPRING WASHER 	8PCS
C	FLAT WASHER 	8PCS
D	M4 ALLEN KEY 	1PC

### Step 1

Place the table top (1) upside down on a soft, clean surface, then attach the table legs (2) using hardware parts A, B, & C. Tighten using hardware D.

**DO NOT use any power tools as this may damage the frame and will invalidate any claim.**

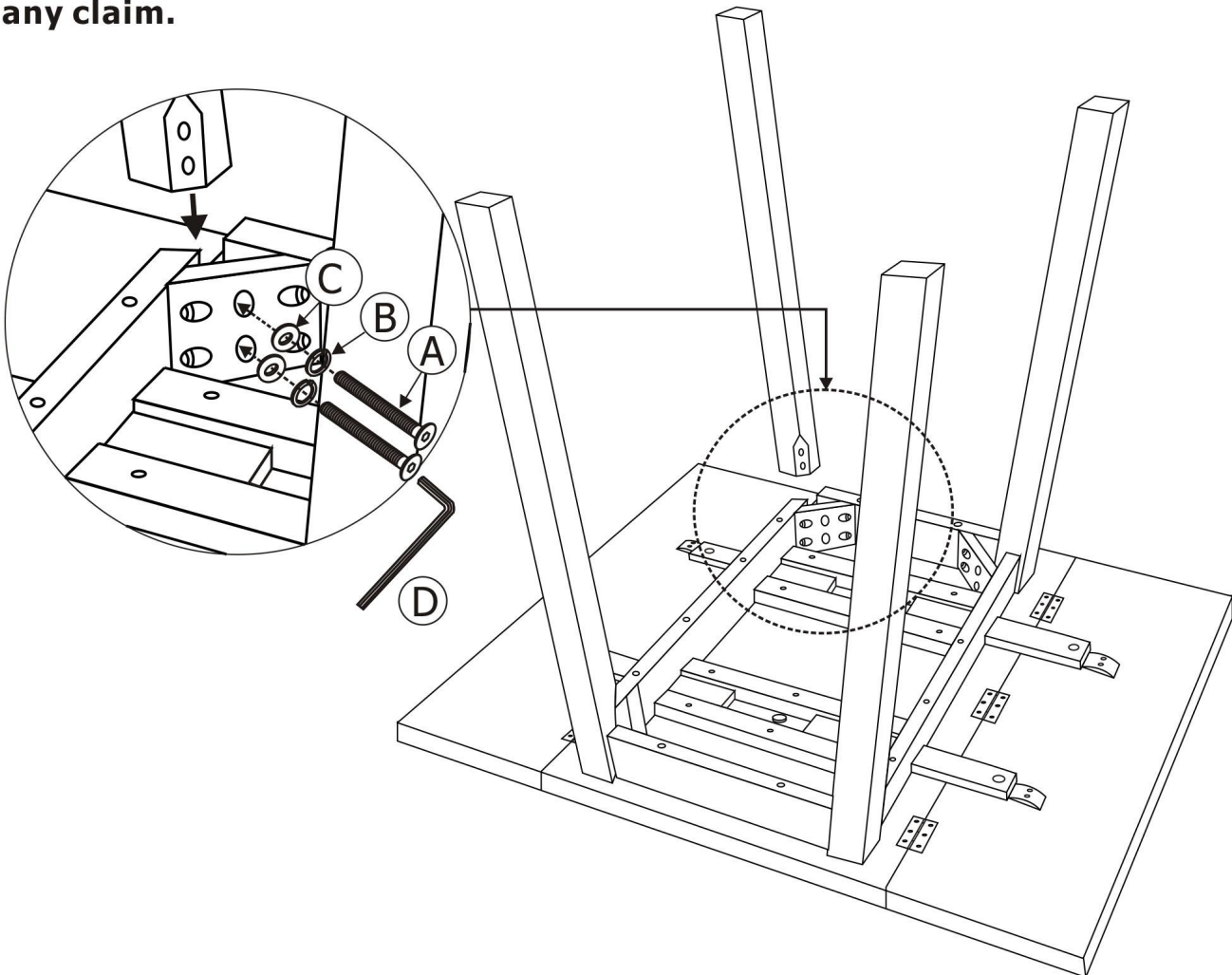

### Additional Information :

- For complete product information, images and dimension diagrams please visit the website
- If you have any issues with your item please contact the retailer directly you purchased it from who will be able to resolve any issues

## ASSEMBLY INSTRUCTIONS DROP LEAF DINING CHAIR

**IMPORTANT: READ THESE INSTRUCTIONS CAREFULLY BEFORE ASSEMBLING OR USING YOUR DINING CHAIR.**

**PLEASE KEEP THESE INSTRUCTIONS FOR FUTURE REFERENCE**

### **HEALTH & SAFETY:**

**DO NOT** use this item if any parts are missing, damaged or worn

**DO NOT** use this item unless all fixings are secured.

Please keep small parts out of reach of children.

Always use on a level, even surface

### **CARE & MAINTENANCE:**

Assemble in the room of use.

Periodically check all screws and fixings to ensure they are secured.

**DO NOT** push the item as this will damage the legs.

Always lift the item with 2 people to reposition.

Keep any sharp objects away from the item.

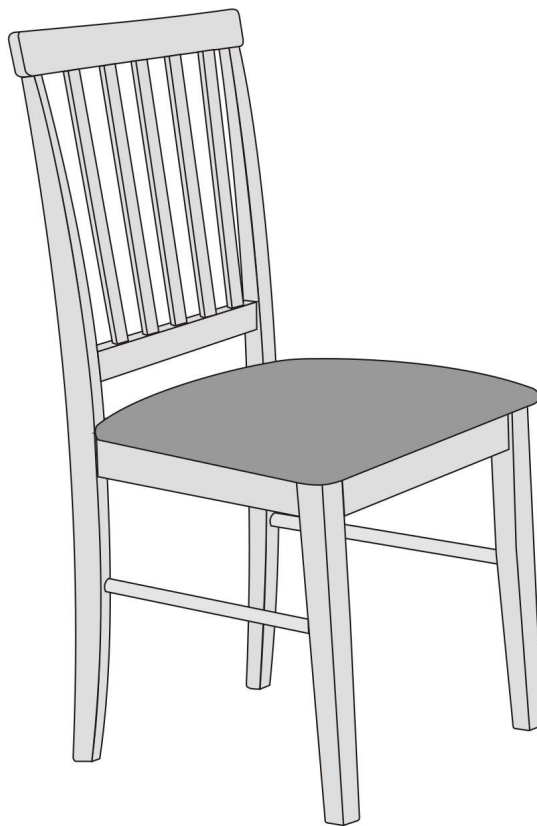

### PARTS LIST

PART	DESCRIPTION	BOX	QTY
1	CHAIR BACK	2	2PCS
2	FRONT LEG	2	2PCS
3	APRON	2	4PCS
4	SEAT	2	2PCS
5	CROSS BAR	2	4PCS

### HARDWARE LIST

PART	DESCRIPTION	QTY
A	JCBC SCREW M6 X 50MM 	12PCS
B	SPRING WASHER 	12PCS
C	FLAT WASHER 	12PCS
D	WOOD SCREW M4 X 32MM 	16PCS
E	M4 ALLEN KEY 	1PC

\*You will need a screwdriver and small mallet (not provided).

#### Step 1

Attach the apron (3) to the front legs (2) using hardware parts A ,B & C. Tighten using hardware E.

**DO NOT use any power tools as this may damage the frame and will invalidate any claim.**

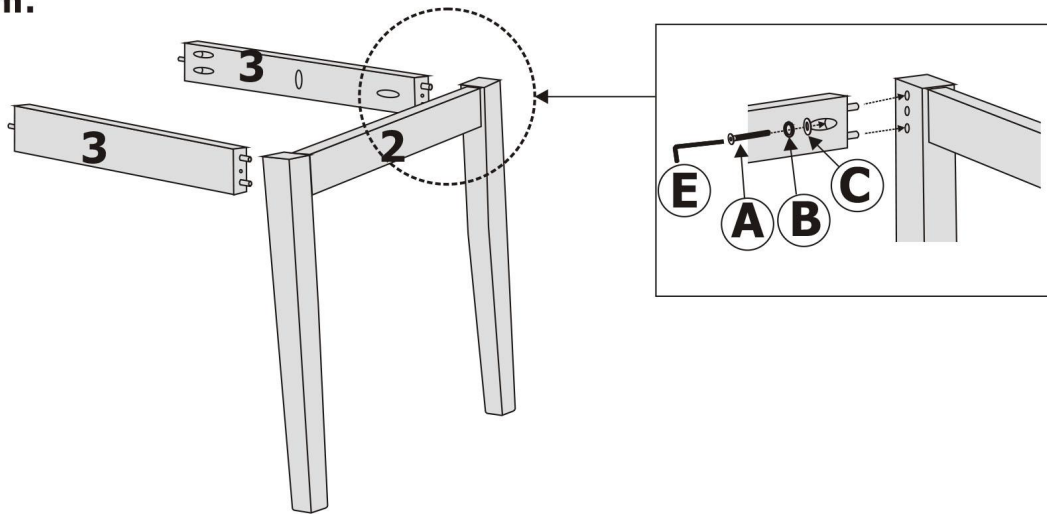

#### Step 2

Attach the apron (3) to the chair back (1) using hardware parts A , B & C and secure using hardware E, but do not fully tighten yet.

Assemble the cross bar using hardware D and tighten with Phillips Screwdriver (not provided).

**DO NOT use any power tools as this may damage the frame and will invalidate any claim.**

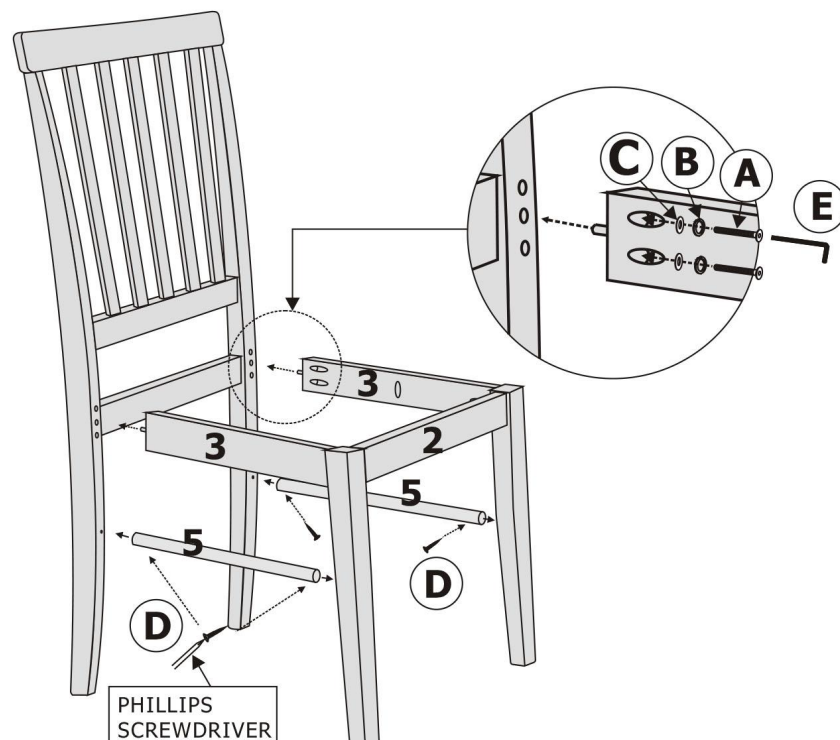

### Step 3

Attach the seat (4) using hardware parts D and tighten with Phillips Screwdriver (Not provided).

**DO NOT use any power tools as this may damage the frame and will invalidate any claim.**

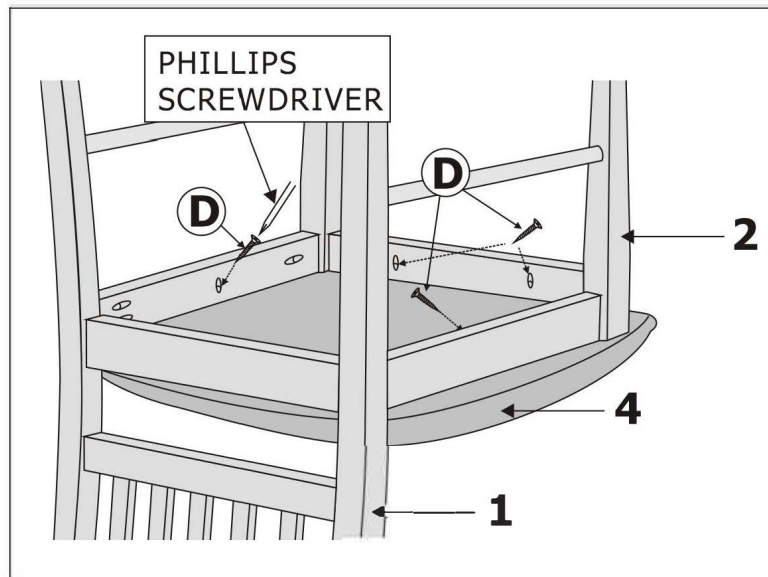

### Additional Information :

- For complete product information, images and dimension diagrams please visit the website
- If you have any issues with your item please contact the retailer directly you purchased it from who will be able to resolve any issues